

Project Title :Kanti Devi

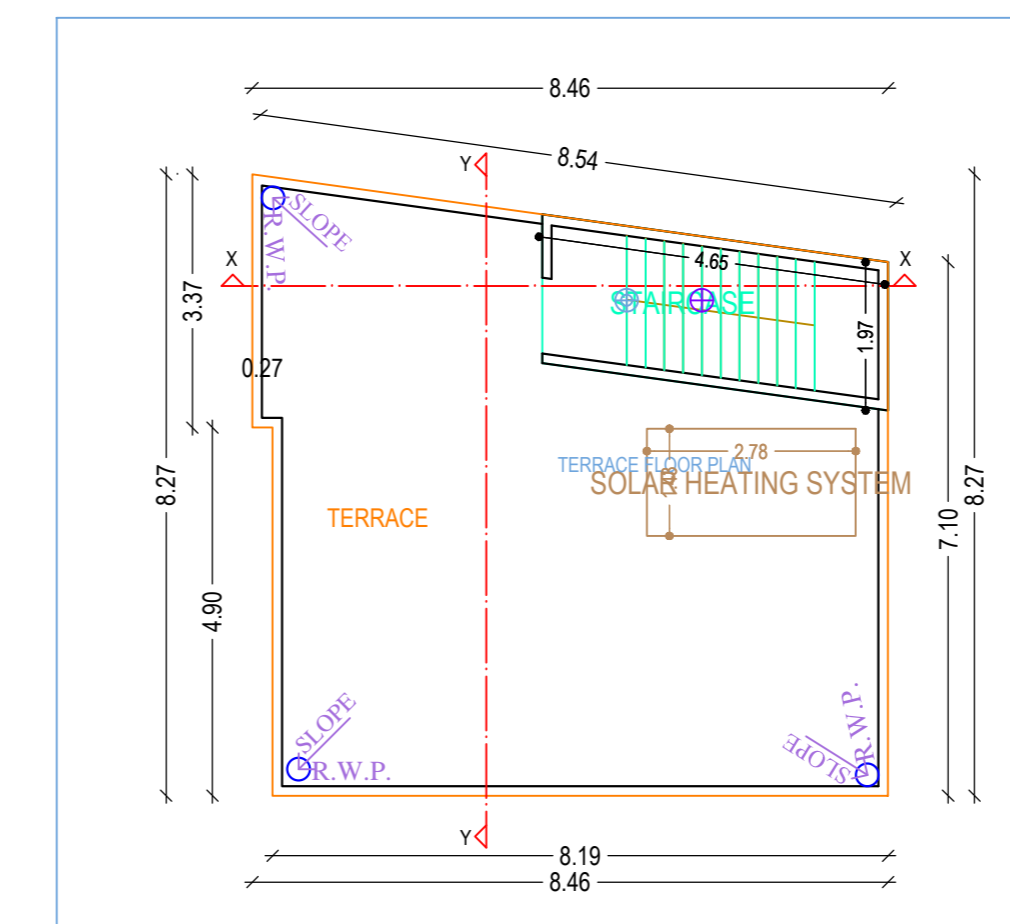
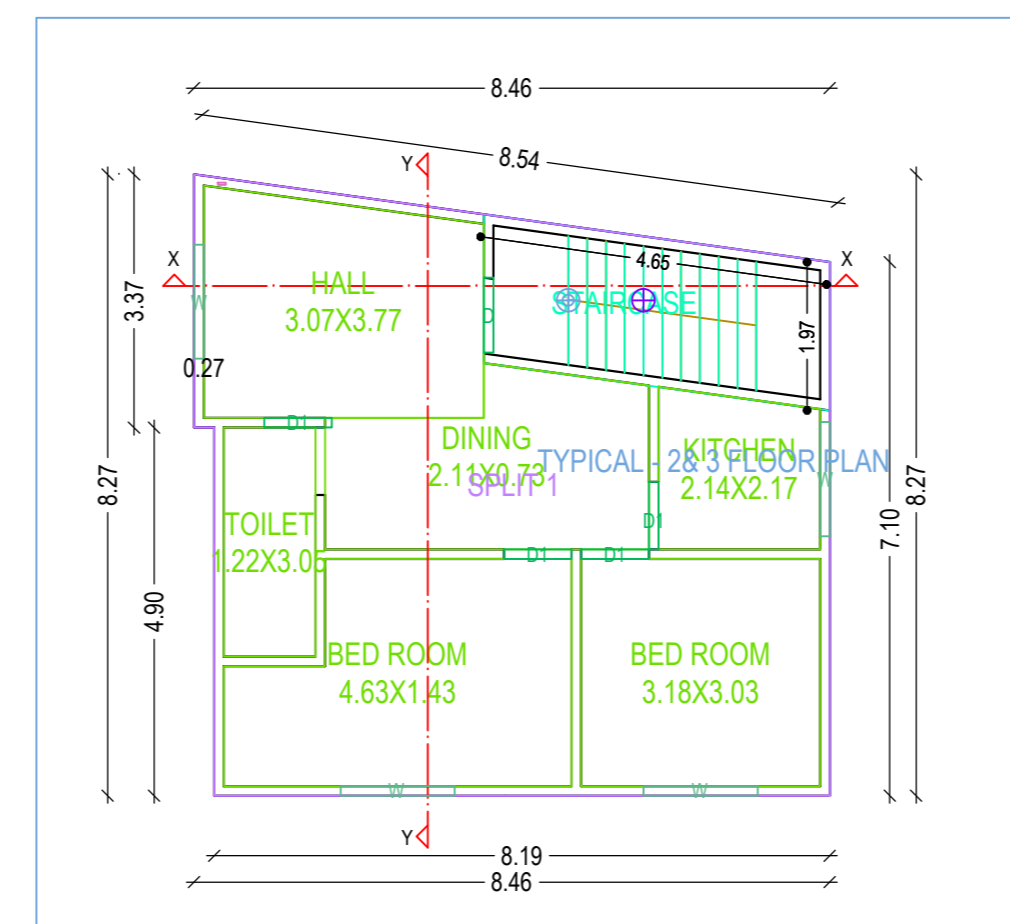
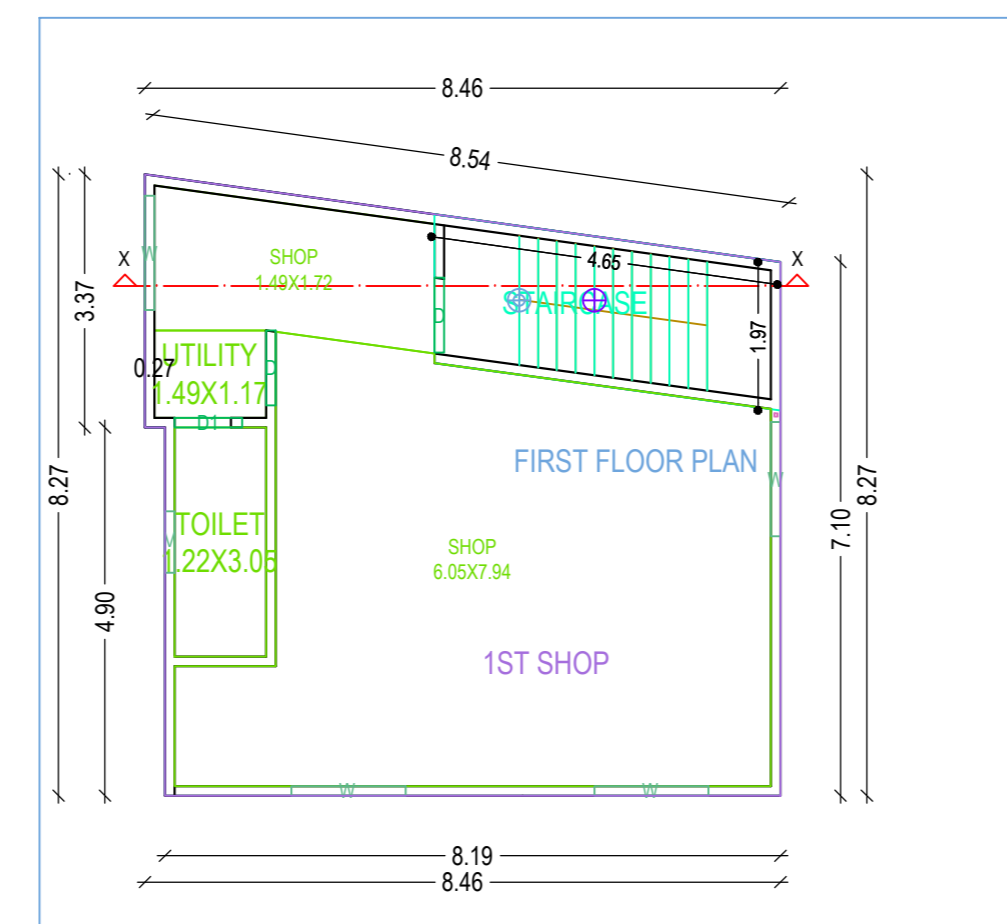
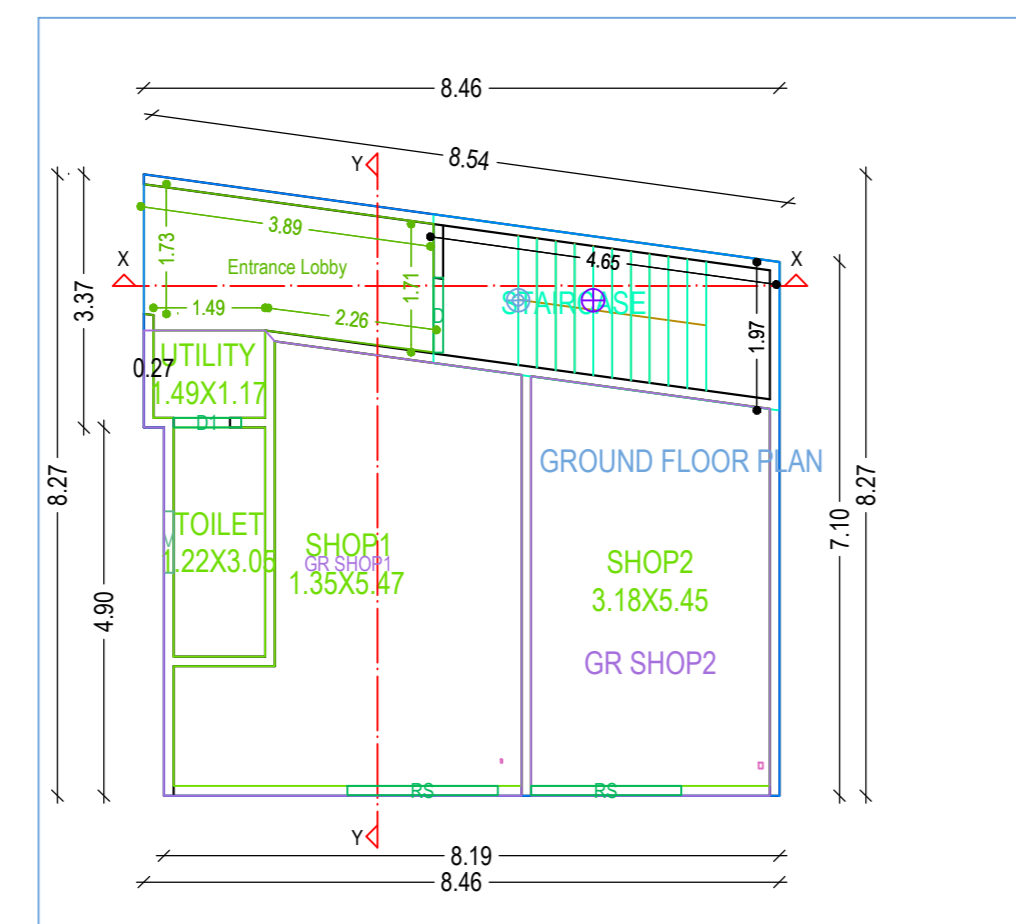
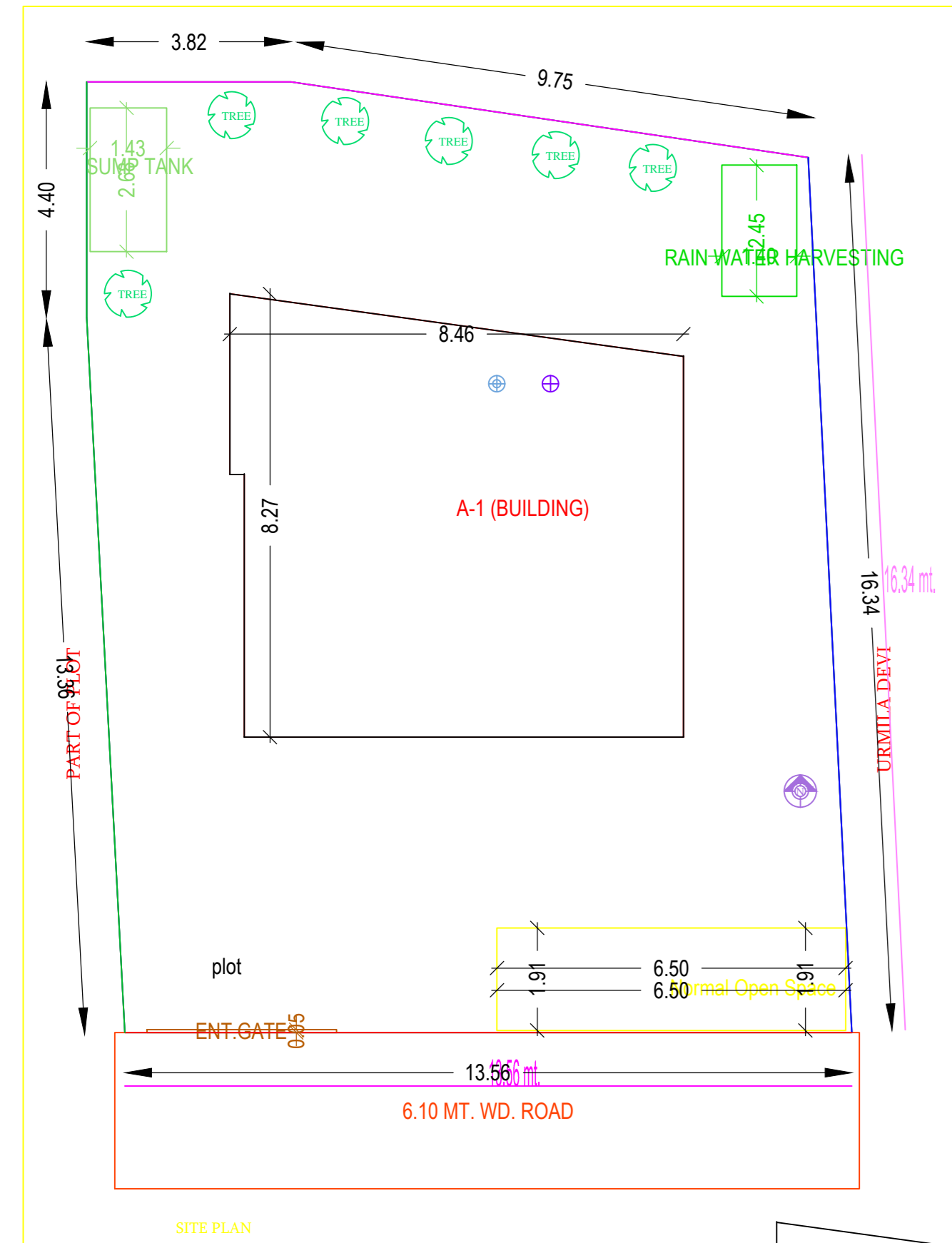
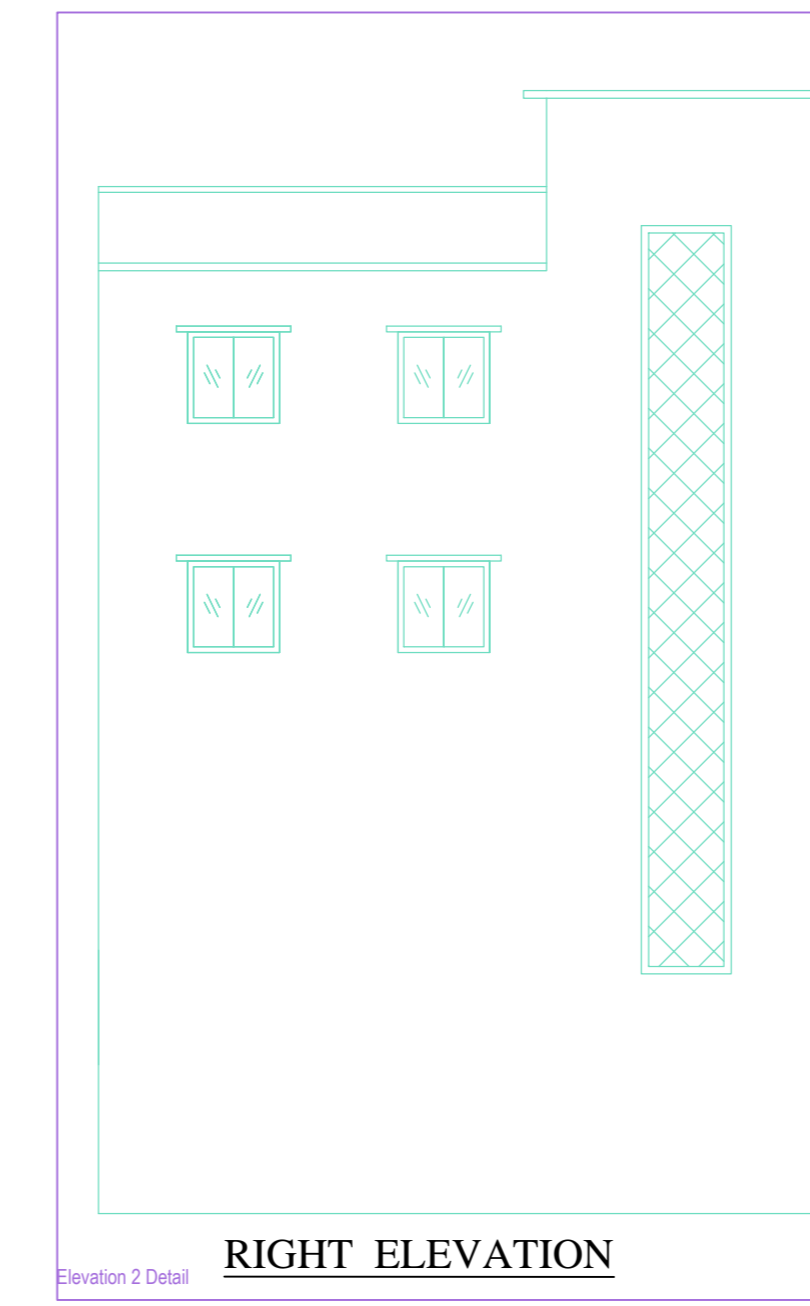
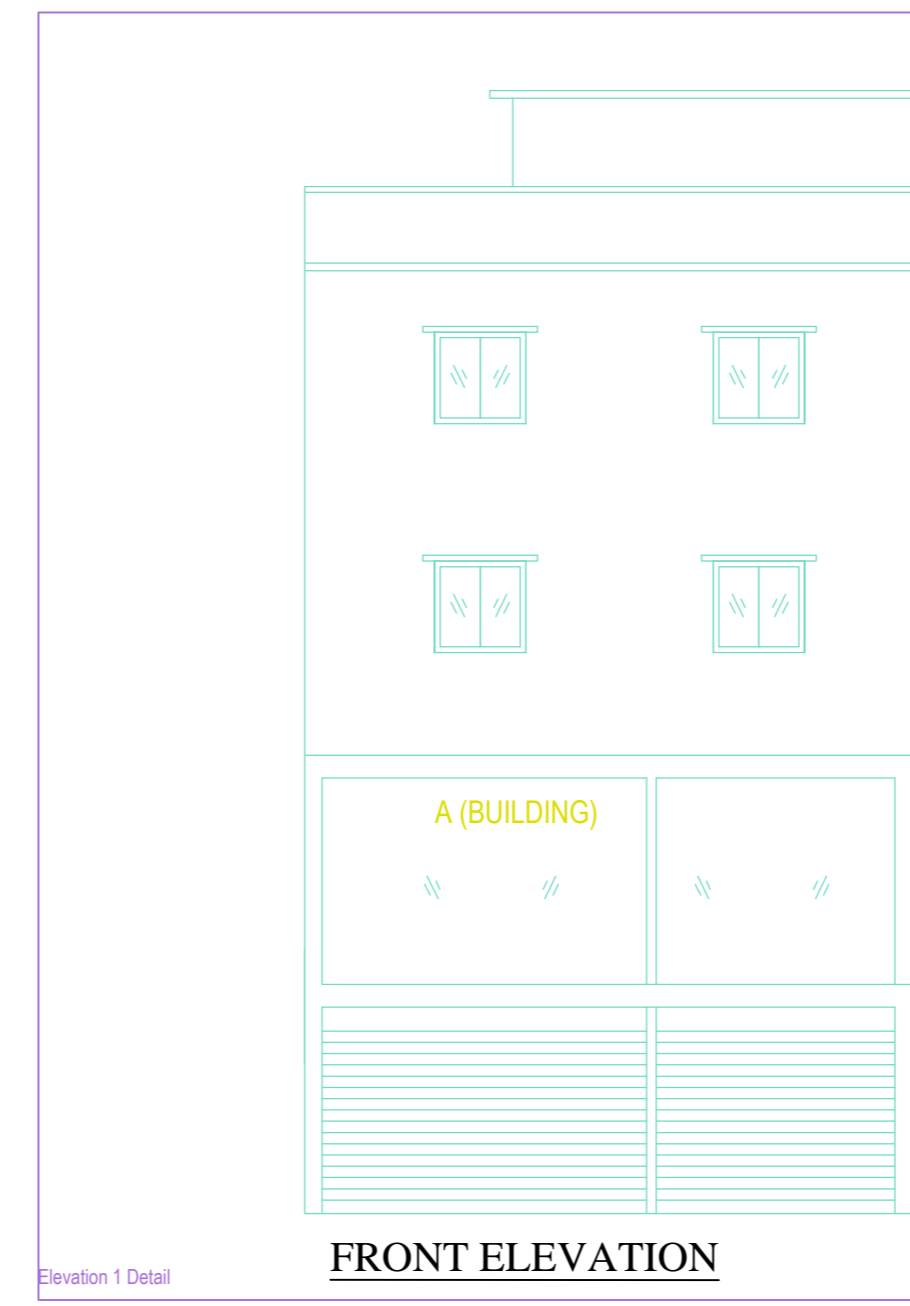
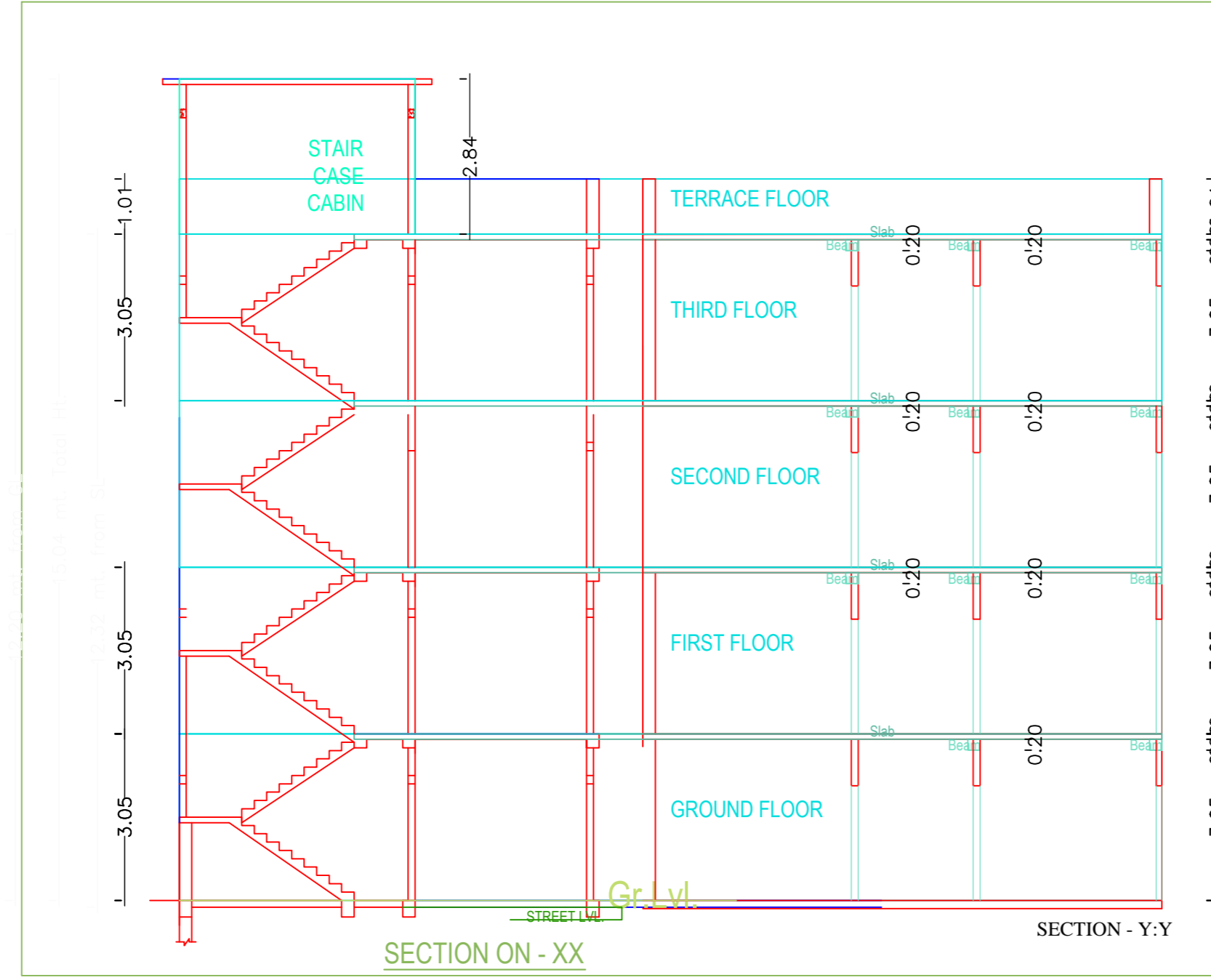
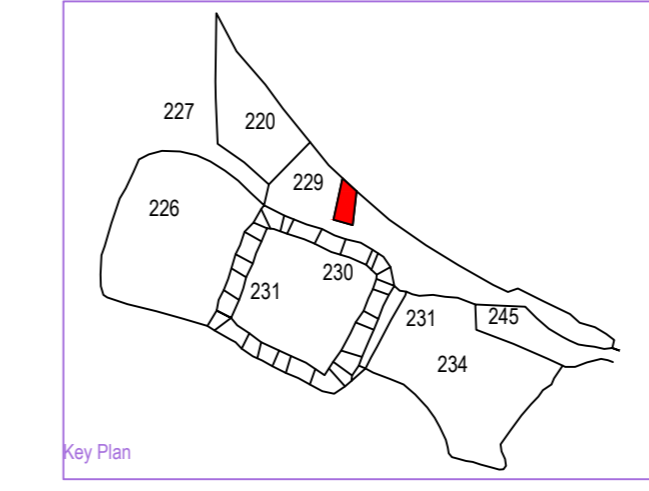
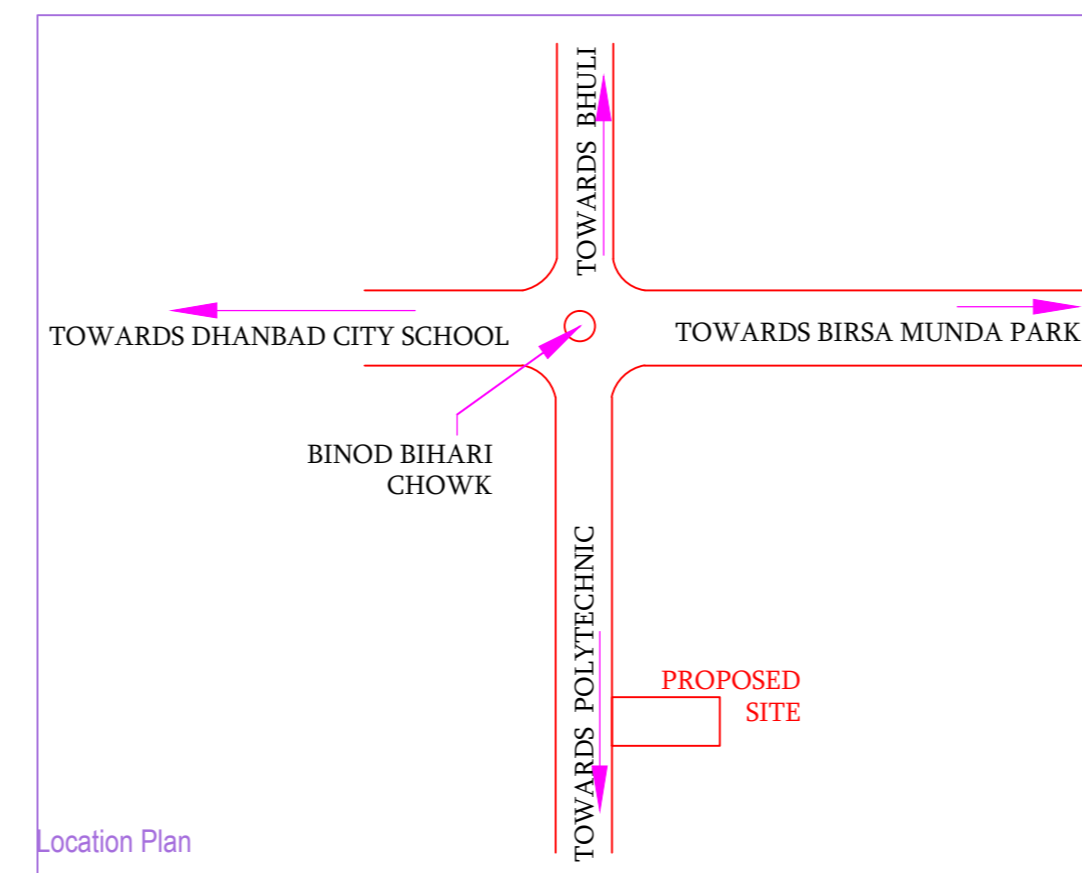
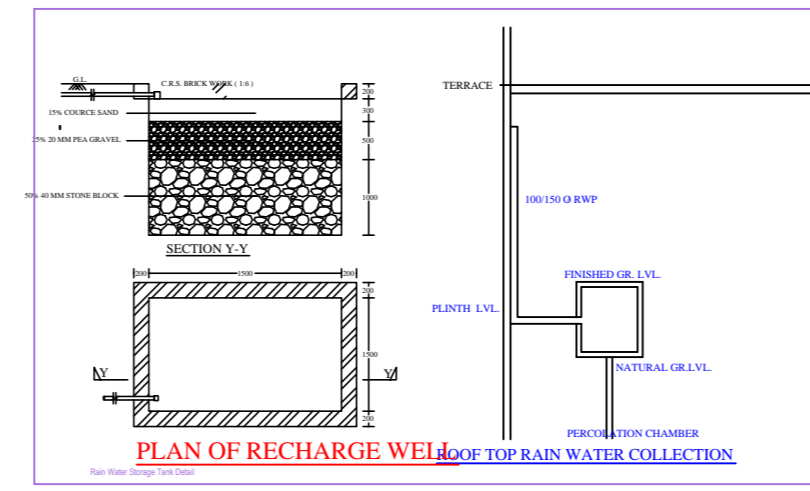
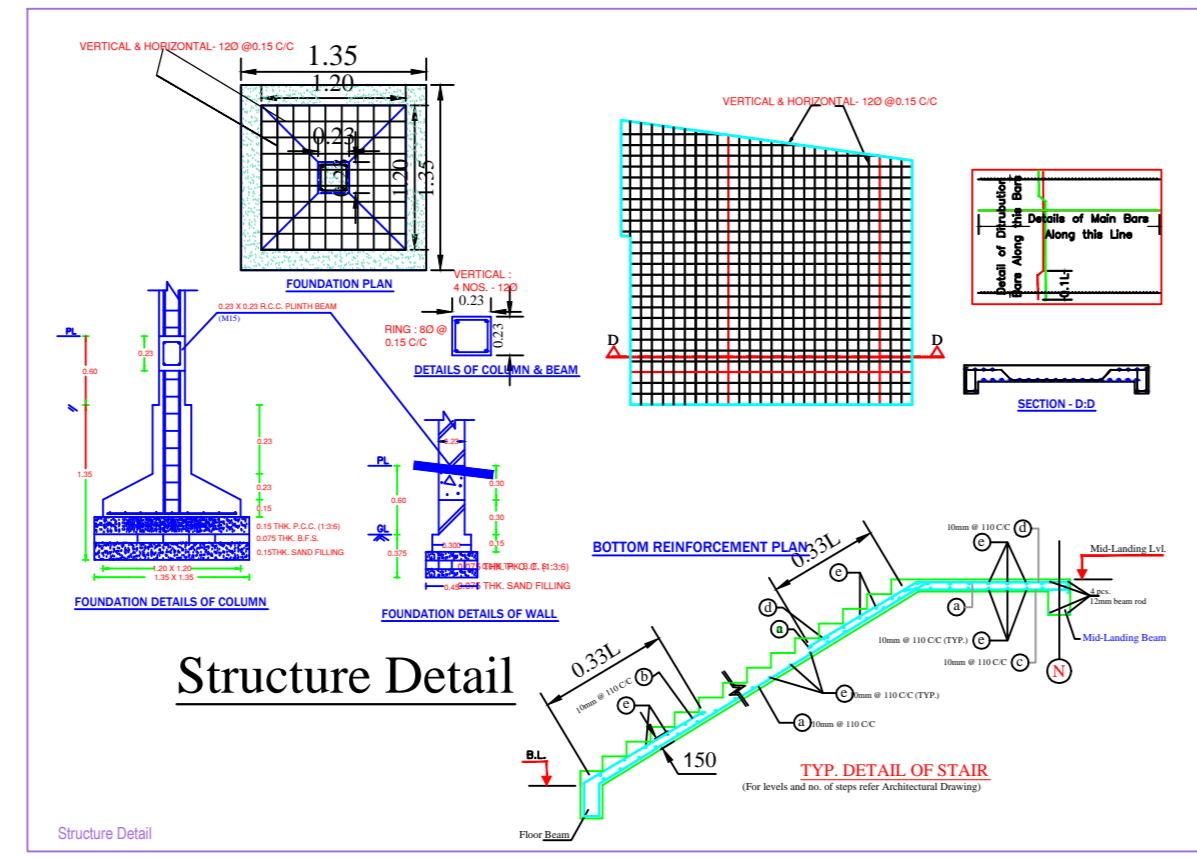

Floor Name	Total Built Up Area (Sq.mt)	Deductions (Area in Sq.mt)		Proposed FAR Area (Sq.mt)		Total FAR Area (Sq.mt)	Trent (No.)
		Accessory Use	Resi.	Resi.	Commercial		
Ground Floor	63.71	6.78	0.00	56.93	56.93	00	
First Floor	63.71	0.00	0.00	63.71	63.71	00	
Second Floor	63.71	0.00	0.00	63.71	63.71	01	
Third Floor	63.71	0.00	0.00	63.71	63.71	01	
Terrace Floor	0.00	0.00	0.00	0.00	0.00	00	
Total	254.84	6.78	0.00	127.42	120.64	248.06	02
Total Number of Same Buildings	1						
Total	254.84	6.78	0.00	127.42	120.64	248.06	02

BUILDING NAME	NAME	LENGTH	HEIGHT	NOS
A (BUILDING)	D1	0.90	2.10	10
A (BUILDING)	D	1.00	2.10	05
A (BUILDING)	RS	2.00	2.10	02
Total				17

BUILDING NAME	NAME	LENGTH	HEIGHT	NOS
A (BUILDING)	V	0.82	1.00	02
A (BUILDING)	W	1.52	1.20	12
Total				14

FLOOR	Name	UNR/UA Type	LnR/UA Area	Carpet Area	No. of Rooms	No. of Tenament
GROUND FLOOR PLAN	GR SHOP1	SHOP	28.59	28.59	3	2
	GR SHOP2	SHOP	17.95	17.95	1	1
FIRST FLOOR PLAN	1ST SHOP	SHOP	63.71	63.71	4	1
TYPICAL 2K 3 FLOOR PLAN	SPLIT 1	FLAT	63.71	63.70	6	2
Total			236.78	236.77	20	5

BRIEF SPECIFICATION
FOUNDATION :- R.C.C. (1:1.5:3) Column footing foundation.
PLINTH :- 0.300 R.C.C. (1:1.5:3) all round on plinth level.
FLOORING :- 0.037 I.P.S. flooring over 0.075 P.C.C. (1:2:4).
SUPER STRUCTURE :- First class brick work in cement mortar (1:6)
SLAB,BEAM & LINTEL :- All R.C.C. work (1:1.5:3).
WOOD WORK :- All door & window frames of sal wood.
PLASTERING :- 0.012 cement plaster (1:6) both side.
*** COLUMN FOOTING** :- Mark in plan just of positioning of column .

SCHEDULE			
D -	1.000 x 2.100	W -	1.800 x 1.200
D1 -	0.900 x 2.100	W1 -	1.200 x 1.200
D2 -	0.750 x 2.100	W2 -	0.900 x 1.200
C.G -	1.500 x 2.100	V -	0.600 x 0.450

DETAILS OF AREA	
AREA OF PLOT ----- (As Per SITE) -----	233.78 Sq.Mt.
PROPOSED AREA	
GROUND FLOOR AREA	56.93 Sq.Mt.
FIRST FLOOR AREA	63.71 Sq.Mt.
SECOND FLOOR AREA	63.71 Sq.Mt.
THIRD FLOOR AREA	63.71 Sq.Mt.
TOTAL PROPOSED AREA	248.06 Sq.Mt.
PLINTH %	27.25 %
FAR	1.06

TITLE OF DRAWING
 RESIDENTIAL BUILDING PLAN OF SMT. KANTI DEVI , W/O SRI KESHOV SINGH , RESIDENT OF D BLOCK BHULI DIST.- DHANBAD PROPOSED UNDER MOUZA - PANDERPALAI No. -. 04. KHATA No. - 63. PLOT No.-229. IN DIST.- DHANBAD .

SIG. OF OWNER

SIG. OF ENGINEER
 ASHOK KUMAR
 DMC/ENG/0011/2017

AREA STATEMENT DHANBAD MUNICIPAL CORPORATION	VERSION NO. 1.0.26
PROJECT DETAIL:	VERSION DATE: 16/10/2020
Project No. :-	Plot Use - Residential
Region :- DHANBAD URBAN LOCAL BODIES	Plot Sub Use :- Bungalow/ Dwelling / Non Apartment
District :- DHANBAD	Land Use Zone :- Residential
Application Type :- General Proposal	Abutting Road Width :-
Project Type :- Building Permission	Plot No. :-
Nature of Development :- New	Revenue Survey No/Survey No. :-
Location :- Old Area	Thana No. :-
Site Location :- NA	Holding No. :-
Village/Mauza Name :-	Khata No. :-
Ward No. :-	North :-
Road/Street :-	South :-
	East :-
	West :-

AREA DETAILS:		SQ.MT.
AREA OF PLOT (Minimum)	(A)	233.78
Net Plot Area (Gross Plot Area - Deduction from Gross Plot area)	(A-Deductions)	233.78
Deductions for Balance Plot Area (from Gross Plot Area)		
COP Area		12.44
Total		12.44
Balance Plot Area (Net Plot Area - Recreational/Amenity space)	(A-Deductions)	221.34
Plot Area for Coverage (Net Plot Area)	(A-Deductions)	233.78
Plot Area for FSI (Net Plot Area + Road/Widening Area)	(A-Deductions)	233.78
COVERAGE CHECK		
Proposed Coverage Area (27.25 %)		63.71
Total Coverage Area (27.25 %)		63.71
FAR CHECK		
Proposed Area of FAR		248.06
Total Area of FAR		248.06
BUILT UP AREA CHECK		
Total Proposed Built Up Area		254.84
ARCHT/ENGG/ SUPERVISOR (Regd)	OWNER	
DEVELOPMENT AUTHORITY	LOCAL BODY	

COLOR INDEX	
PILOT BOUNDARY	-----
ABUTTING ROAD	-----
PROPOSED WORK (COVERAGE AREA)	-----
EXISTING (To be retained)	-----
EXISTING (To be demolished)	-----

MARGIN DETAIL:					
Building / Wing Name	Road Name	Front Margin	Rear Margin	Side1 Margin	Side2 Margin
A-1 (BUILDING)	6 TO MT. WD. ROAD	5.51	3.95	2.51	2.51

FAR & Tenement Details (Table 4c-1)						
Building	No. of Same Bldg	Total Built Up Area (Sq.mt)	Deductions (Area in Sq.mt)	Proposed FAR Area (Sq.mt)	Total FAR Area (Sq.mt)	Trent (No.)
A (BUILDING)	1	254.84	6.78	127.42	120.64	248.06
Grand Total:	1	254.84	6.78	127.42	120.64	248.06