

Proposal Basic Information	
Proposal File No.	DMC/BP/0178/W23/2021
Owner Name	DIPAK BANERJEE
Khata No	30(OLD),600(NEW)
Plot No	1723(OLD),2298(NEW)
Village Name	Kolakusma
Use	Residential
SubUse	Bungalow/ Dwelling / Non Apartment

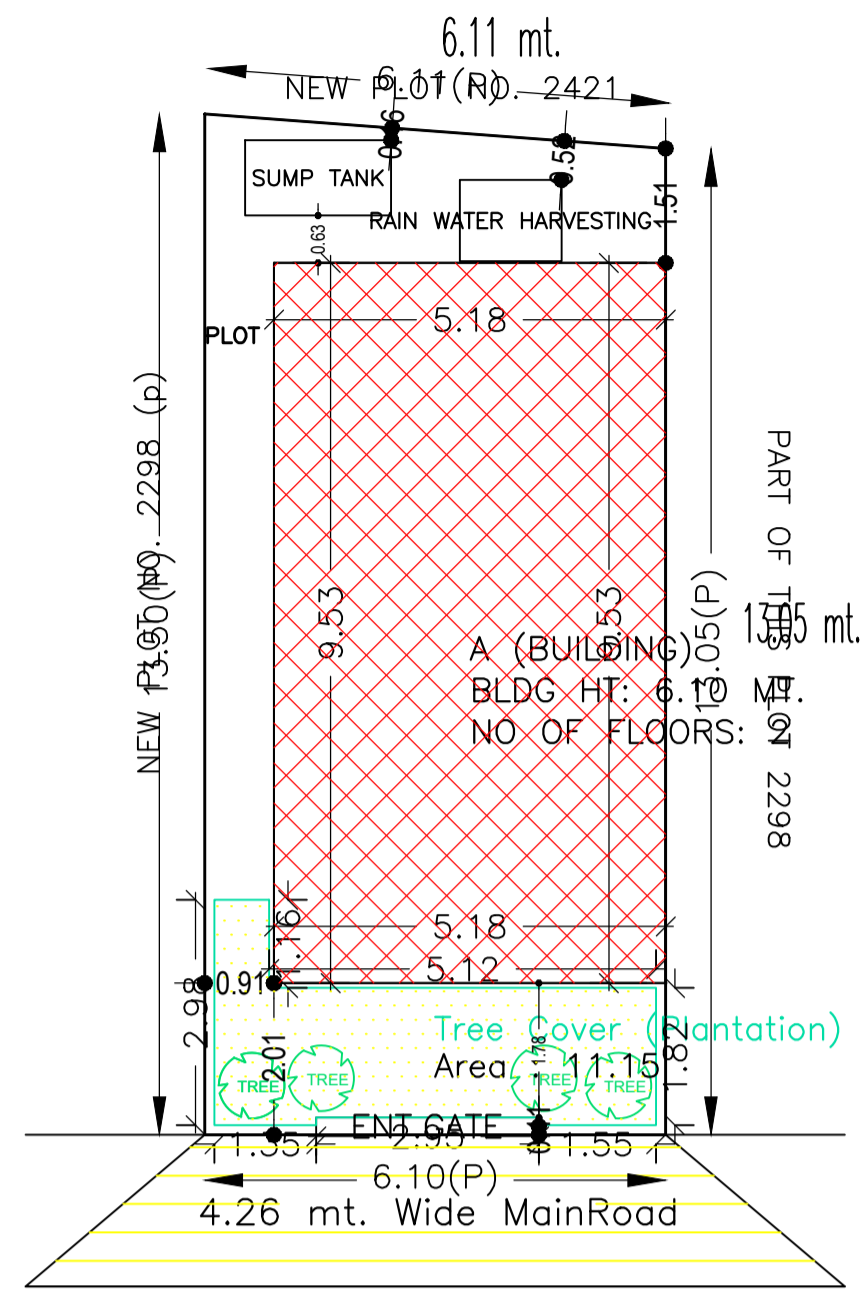

SITE PLAN

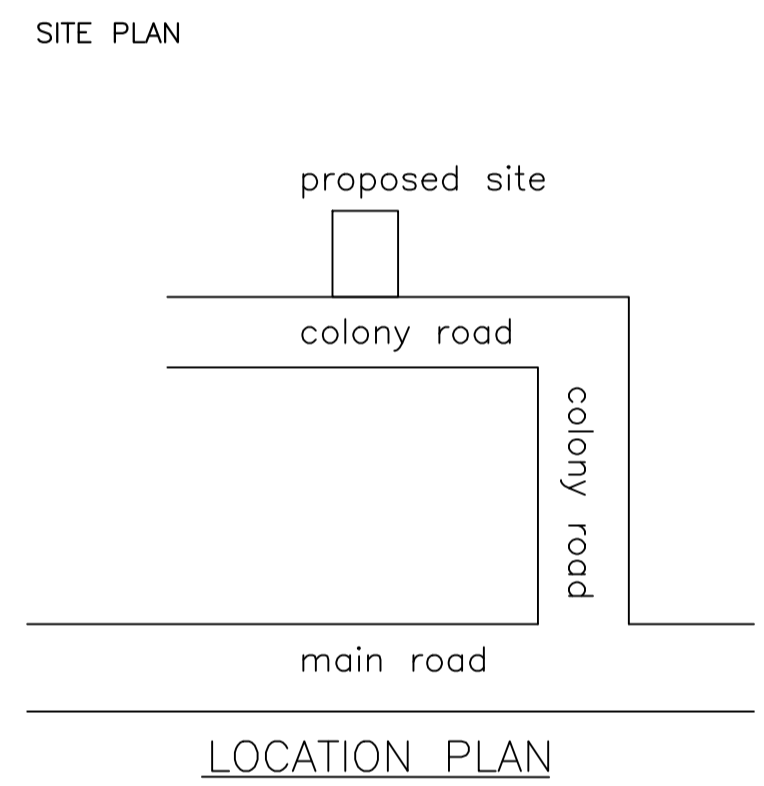

LOCATION PLAN

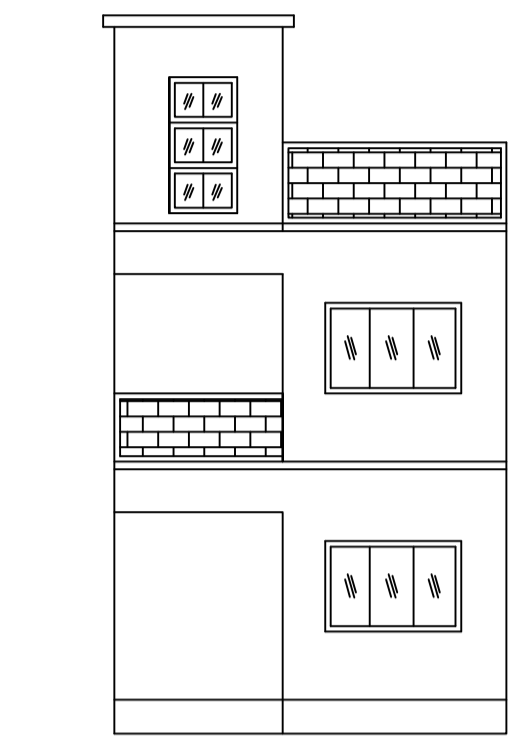
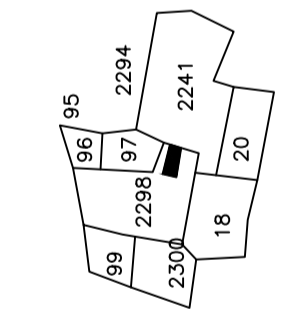
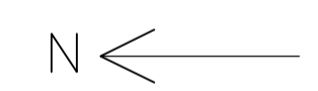

FRONT ELEVATION

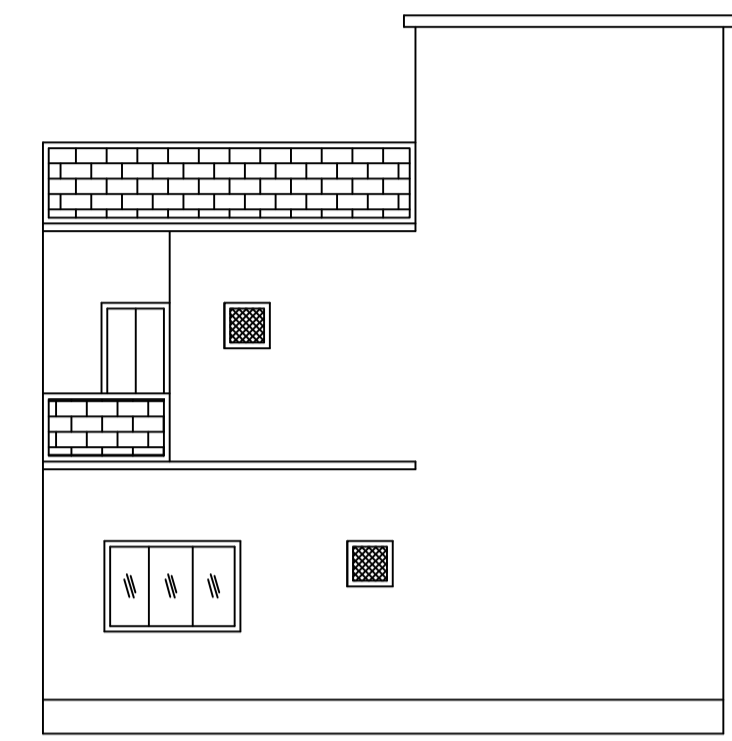

LEFT SIDE ELEVATION

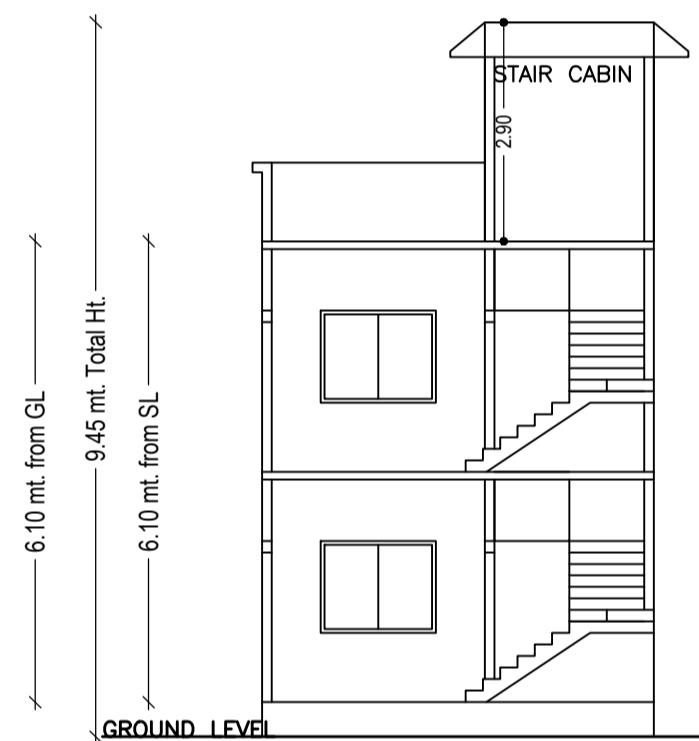

SECTION X-X

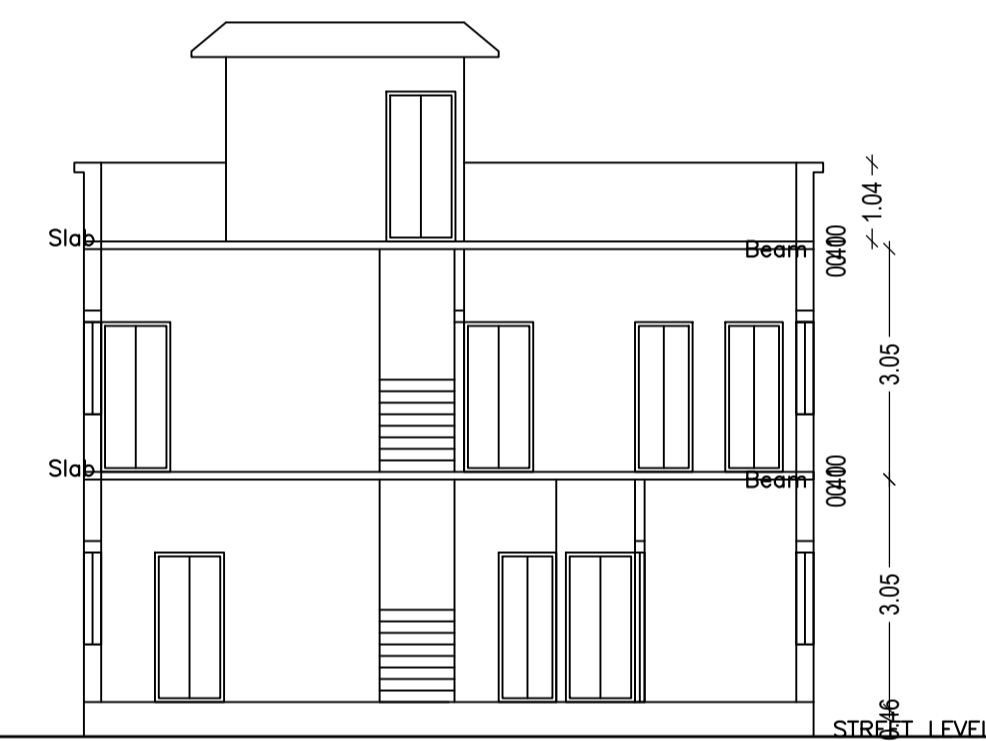

SECTION Y-Y

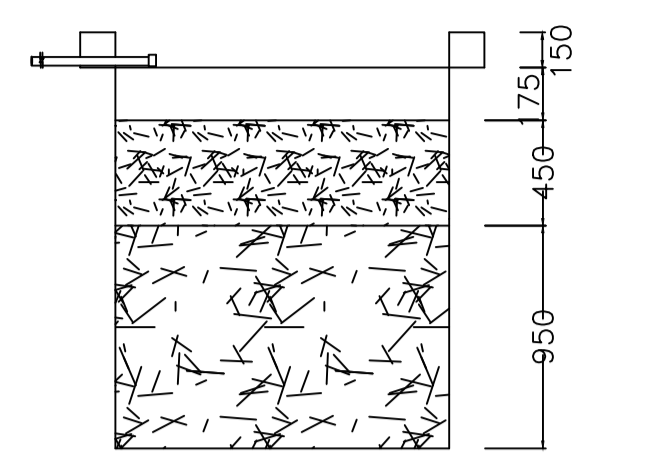

SECTION AT Y-Y

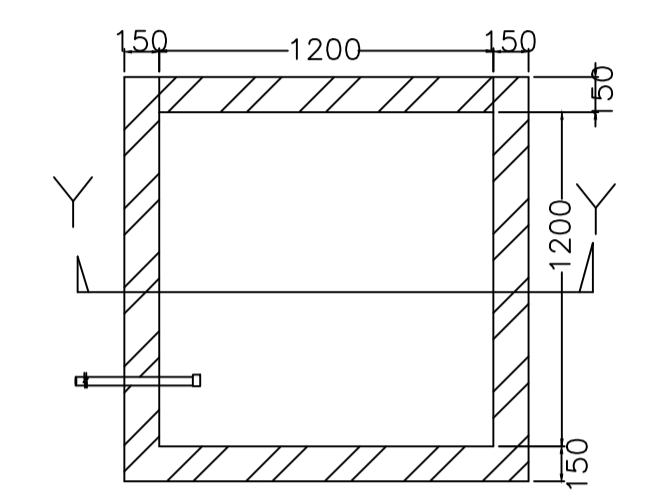

PLAN OF RECHARGE WELL

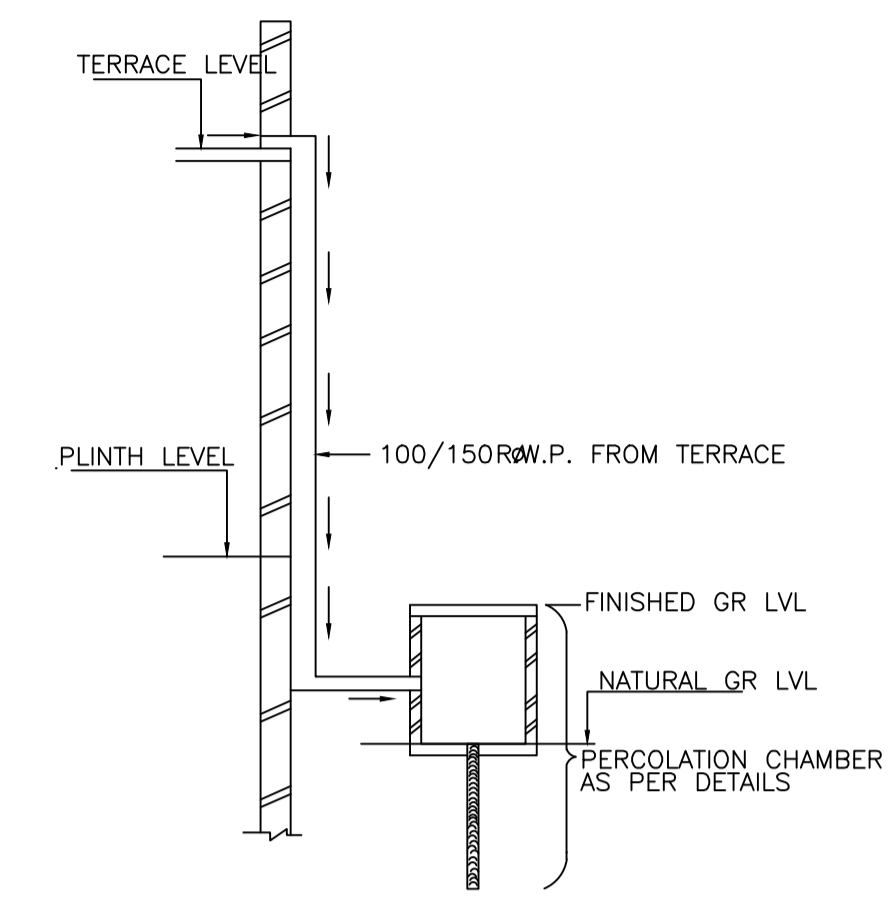

ROOF TOP RAIN WATER COLLECTION SYSTEM

WATER HARVESTING

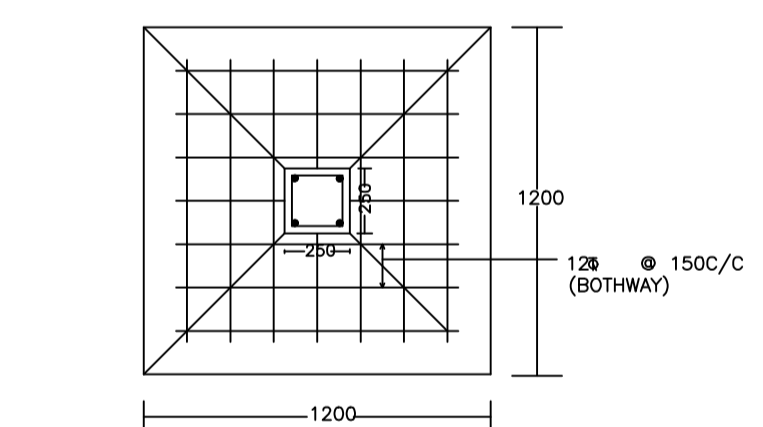
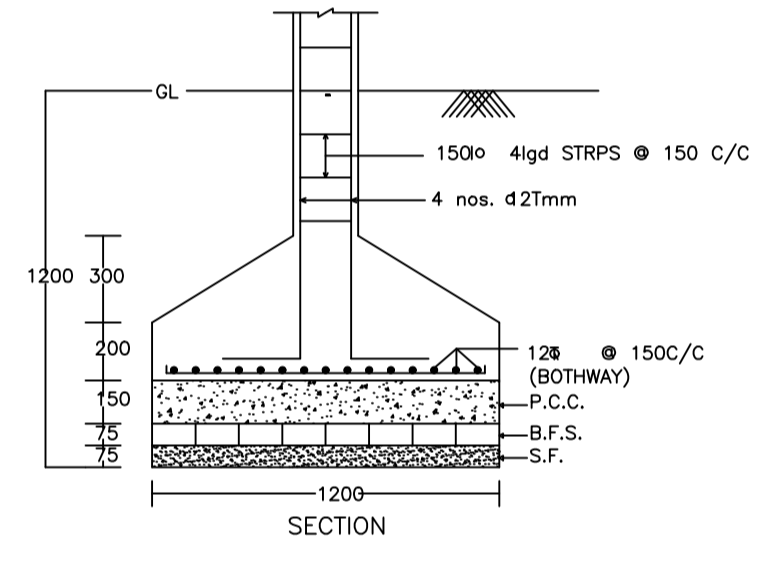
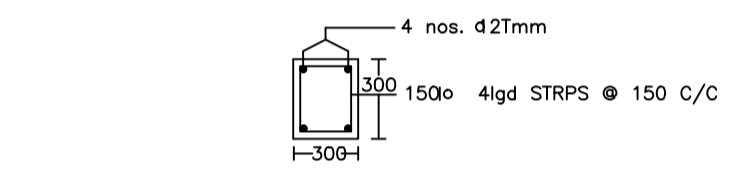

DETAIL OF COLUMNS

Building :A (BUILDING)

Floor Name	Total Built Up Area (Sq.mt.)	Proposed FAR Area (Sq.mt.)	Total FAR Area (Sq.mt.)	Total Consumed Additional FAR Area (Sq.mt.)	Trmt (No.)
Ground Floor	49.35	49.35	49.35	49.35	01
First Floor	49.35	49.35	49.35	49.35	00
Terrace Floor	0.00	0.00	0.00	0.00	00
Total :	98.70	98.70	98.70	98.70	01
Total Number of Same Buildings :	1				
Total :	98.70	98.70	98.70	98.70	01

SCHEDULE OF DOOR:

BUILDING NAME	NAME	LENGTH	HEIGHT	NOS
A (BUILDING)	D2	0.76	2.10	04
A (BUILDING)	D1	0.91	2.10	04
A (BUILDING)	D	1.05	2.10	02

SCHEDULE OF WINDOW/VENTILATION:

BUILDING NAME	NAME	LENGTH	HEIGHT	NOS
A (BUILDING)	V	0.85	1.20	07
A (BUILDING)	W2	1.19	1.20	01
A (BUILDING)	W	1.69	1.20	07
A (BUILDING)	W	1.84	1.20	01
A (BUILDING)	W	2.40	1.20	02

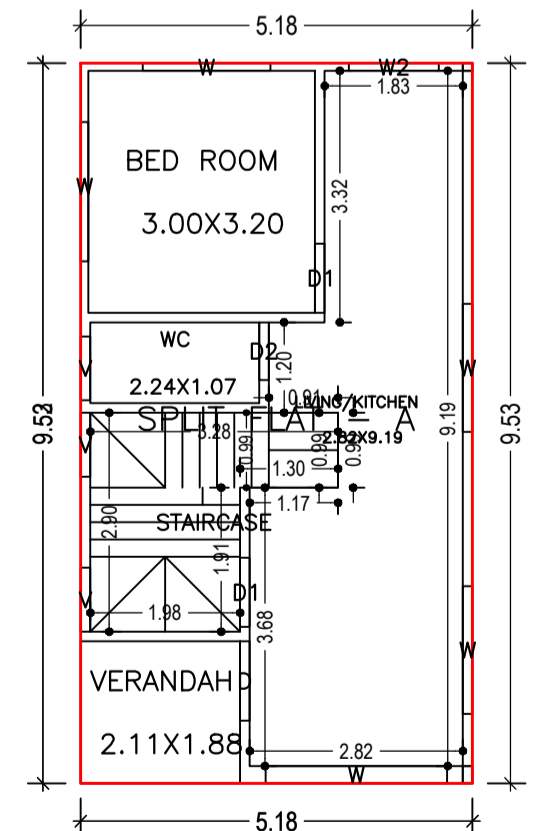

GROUND FLOOR PLAN (Proposed) (SCALE 1:100)

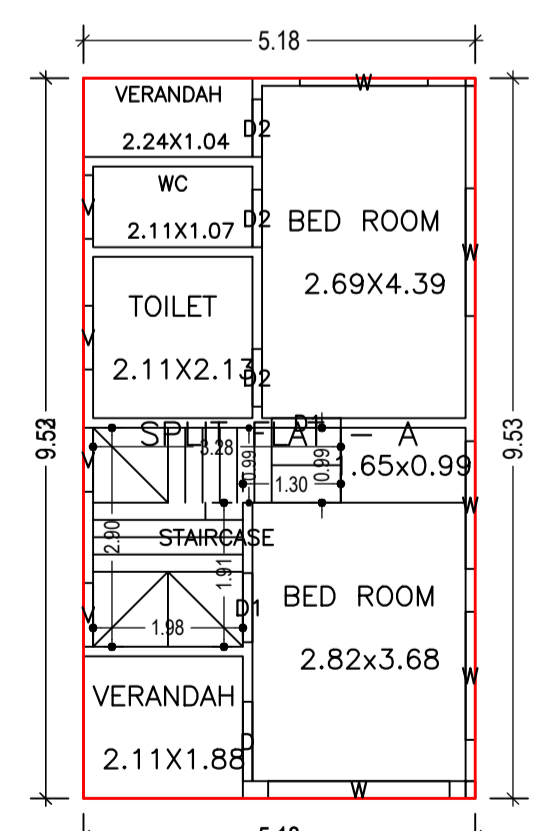

FIRST FLOOR PLAN (Proposed) (SCALE 1:100)

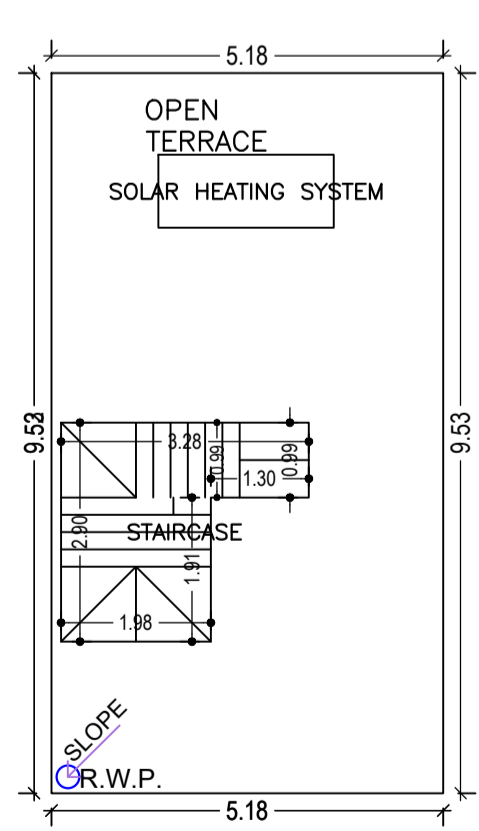

TERRACE FLOOR PLAN (SCALE 1:100)

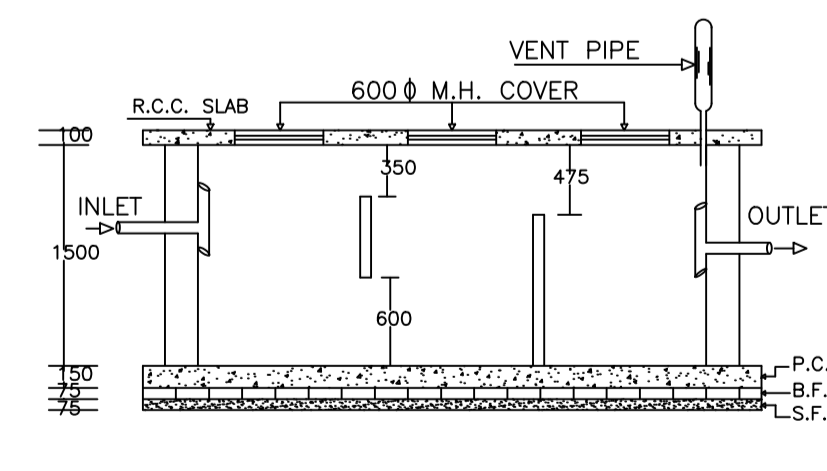

PLAN OF SEPTIC TANK

AREA STATEMENT		VERSION NO.:	1.0.60
DHANBAD MUNICIPAL CORPORATION		VERSION DATE: 16/10/2020	
PROJECT DETAIL:			
Region: JHARKHAND URBAN LOCAL BODIES	Plot Use: Residential		
District: DHANBAD	Plot SubUse: Bungalow/ Dwelling / Non Apartment		
Authority: DHANBAD MUNICIPAL CORPORATION	PlotNearbyReligiousStructure: NA		
Inward No: DMC/BP/0178/W23/2021	Plot/SubPlot No: 1723(OLD),2298(NEW)		
Application Type: General Proposal	North: Plot No. - NEW PLOT NO 2298		
Project Type: Building Permission	South: Plot No. - PART OF THIS PLOT NEW 2298		
Nature of Development: New	East: Plot No. - NEW PLOT NO 2421		
Location of Development Area: Old Area	West: Road Width - 4.26		
AREA DETAILS:			SQ.MT.
AREA OF PLOT (Minimum)	(A)		80.92
NET AREA OF PLOT (Gross Plot Area - Deduction from Gross Plot Area)	(A-Deductions)		80.92
Deduction for Balance Plot Area (from Gross Plot Area)			
Common Plot			11.15
Total			11.15
BALANCE AREA OF PLOT (Net Plot Area - Recreational/Amenity space)	(A-Deductions)		69.77
PLOT AREA FOR COVERAGE (Net Plot Area)	(A-Deductions)		80.92
Plot Area for FAR (Net Plot Area + Road Widening Area)	(A-Deductions)		80.92
COVERAGE CHECK			
Permissible Coverage area ( 70.00 % )			56.64
Proposed Coverage Area ( 60.99 % )			49.35
Total Prop. Coverage Area ( 60.99 % )			49.35
Balance coverage area ( 9.01 % )			7.29
FAR CHECK			
Perm. FAR Area ( 1.50 )			121.38
Total Perm. FAR area			121.38
Residential FAR			98.71
Proposed FAR Area			98.71
Total Proposed FAR Area			98.71
Consumed FAR (Factor)			1.22
Balance FAR Area			22.67
BUILT UP AREA CHECK			
Total Proposed BuiltUp Area			98.70
ARCHITECT (Regd)		PARTHA - PAL	
ENGINEER (Regd)			
SUPERVISOR (Regd)			
OWNER (Regd)		DIPAK BANERJEE	
DEVELOPMENT AUTHORITY		LOCAL BODY	

COLOR INDEX

PLOT BOUNDARY	Black
ABUTTING ROAD	Green
PROPOSED CONSTRUCTION	Red
COMMON PLOT	Yellow
ROAD WIDENING AREA	Blue
EXISTING (To be retained)	Light Blue
EXISTING (To be demolished)	Dark Blue

Buildingwise Floor FAR Details

Floor Name	Building Name		Total	
	Proposed Built Up Area (Sq.mt.)	Proposed FAR Area (Sq.mt.)	Total Proposed Built Up Area (Sq.mt.)	Total FAR Area (Sq.mt.)
Ground Floor	49.35	49.35	49.35	49.35
First Floor	49.35	49.35	49.35	49.35
Terrace Floor	0.00	0.00	0.00	0.00
Total :	98.70	98.70	98.70	98.70

Building USE/SUBUSE Details

Building Name	Building Use	Building SubUse	Building Structure
A (BUILDING)	Residential	Bungalow/ Dwelling / Non Apartment	Non-Highrise

FAR & Tenement Details (Table 4c-1)

Building	No. of Same Bldg	Total Built Up Area (Sq.mt.)	Proposed FAR Area (Sq.mt.)	Total FAR Area (Sq.mt.)	Total Consumed Additional FAR Area (Sq.mt.)	Trmt (No.)
A (BUILDING)	1	98.70	98.70	98.70	98.70	01
Grand Total :	1	98.70	98.70	98.70	98.70	01

UnitBUA Table for Building :A (BUILDING)

FLOOR	Name	UnitBUA Type	UnitBUA Area	Carpet Area	No. of Rooms	No. of Tenement
GROUND FLOOR PLAN	SPLIT FLAT - A	FLAT	98.71	98.63	4	1
FIRST FLOOR PLAN	SPLIT FLAT - A	FLAT	0.00	0.00	6	0
Total:	-	-	98.71	98.63	10	1

LTP NAME AND SIGNATURE	STRUCTURAL ENG'S NAME AND SIGNATURE	BUILDER NAME AND SIGNATURE	DIGITAL SIGNATURE
PARTHA - PAL DMC/ENG/0021/2016			