

Project Title :SRI DIPAK BANERJEE

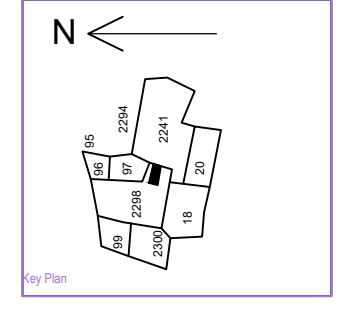
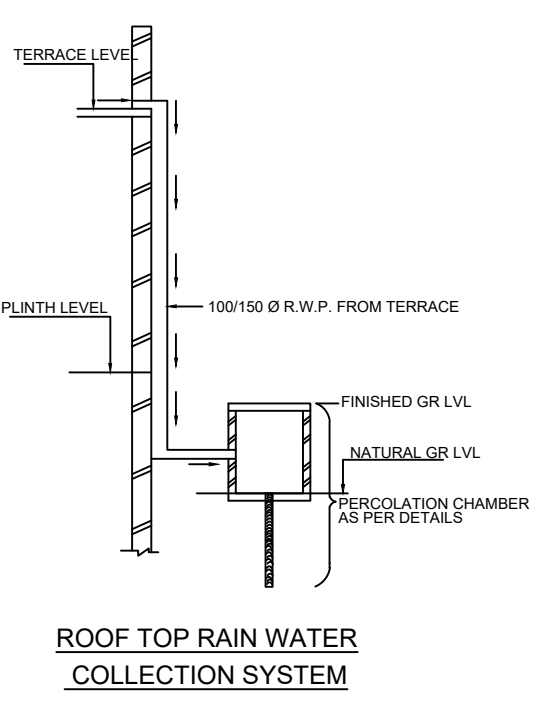
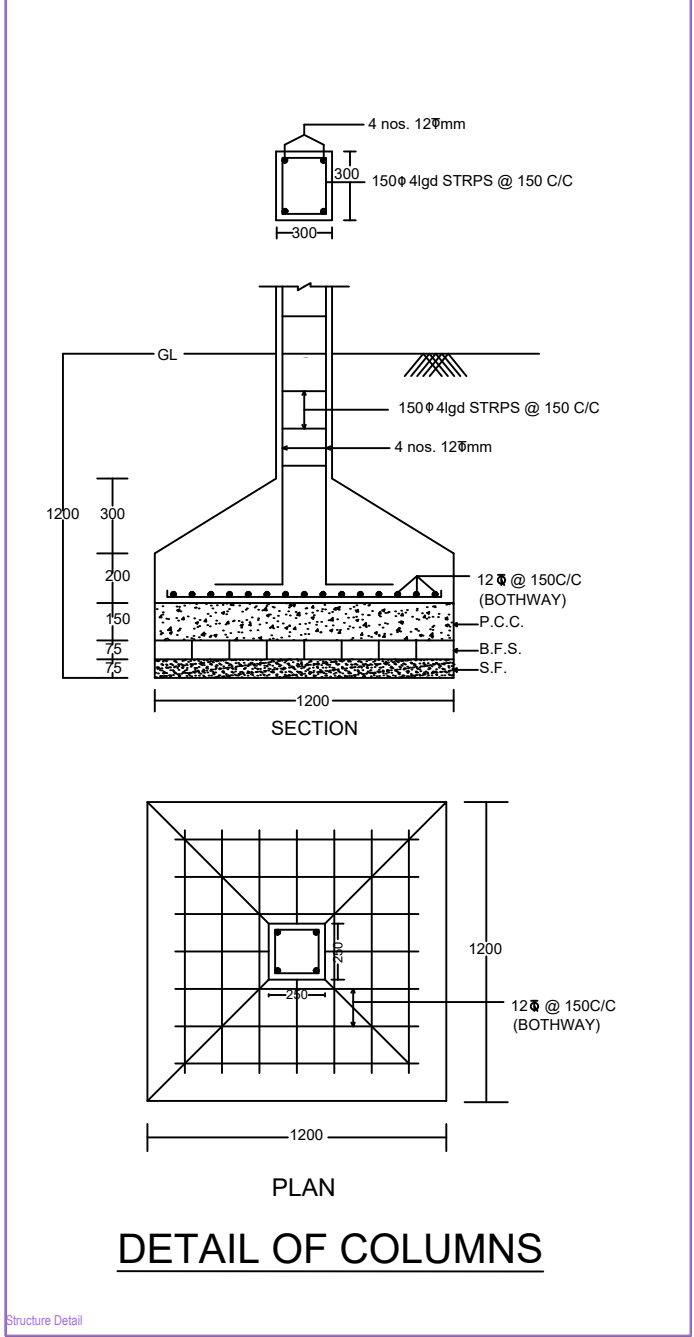
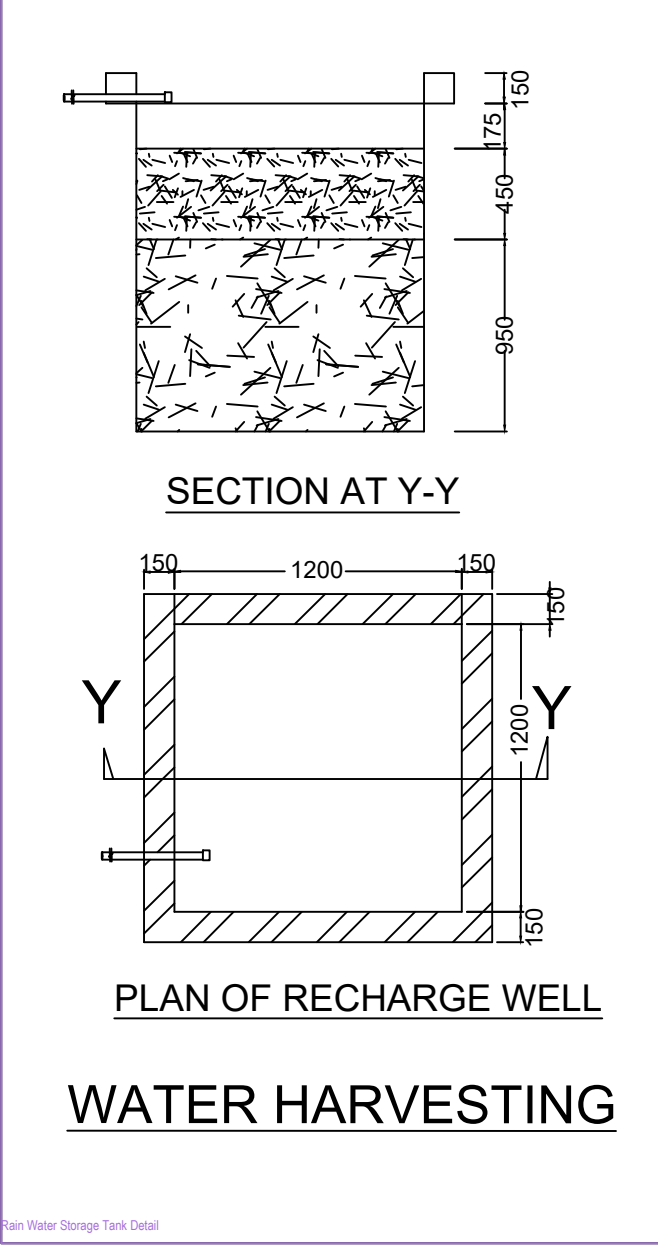
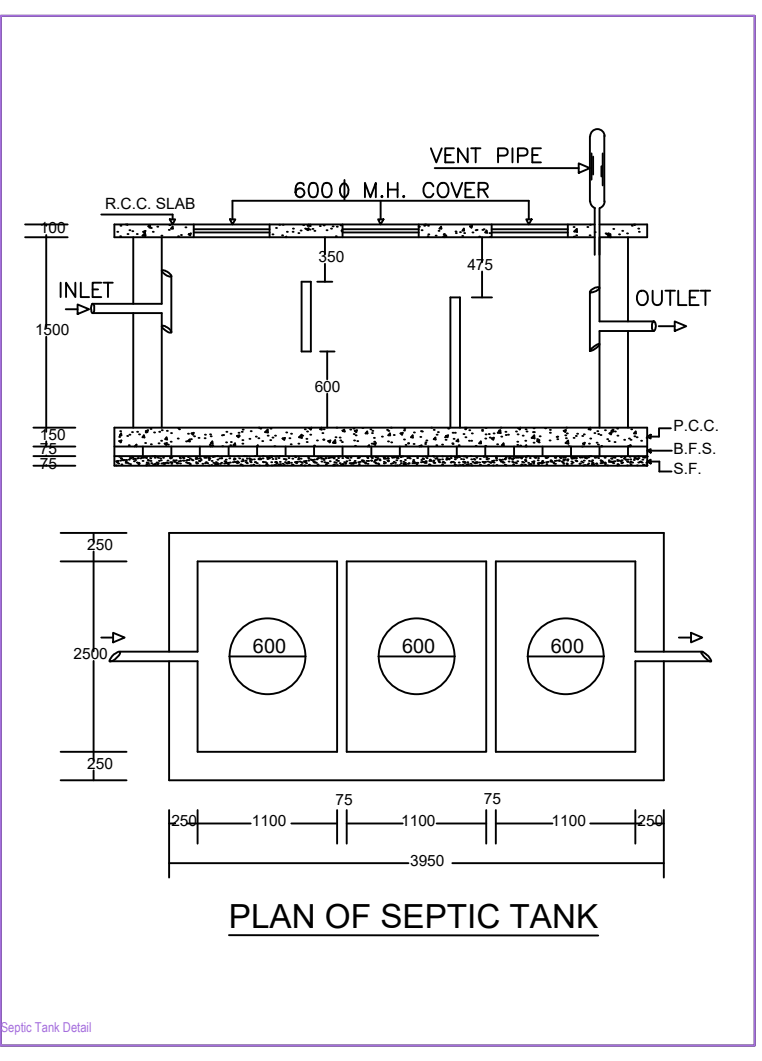
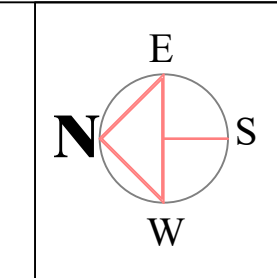
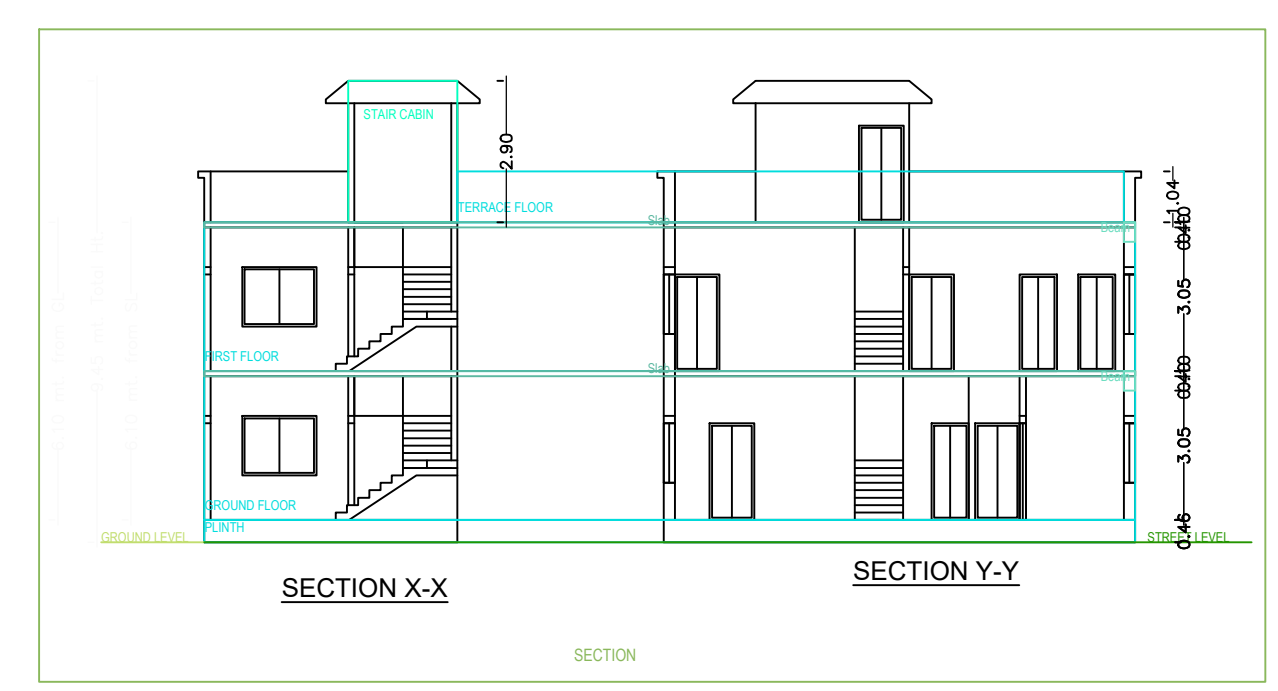
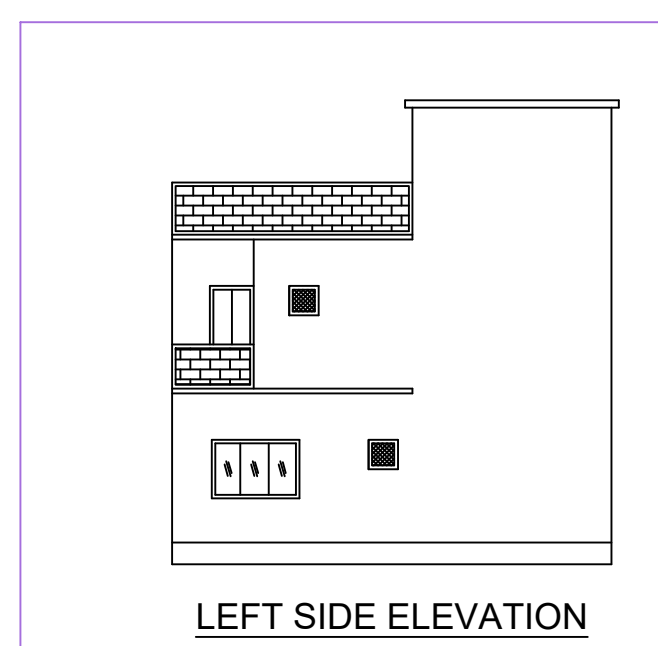
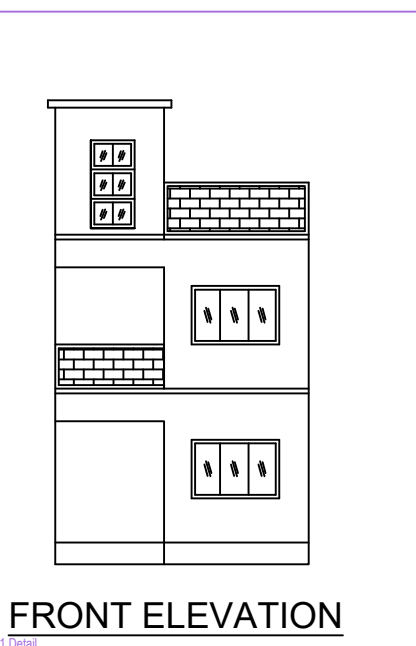

BRIEF SPECIFICATION

FOUNDATION..... CEMENT CONCRETE (1:1.5:3)
 BRICK WORK IN FOUNDATION & SUPERSTRUCTURE
 FIRST CLASS BRICK WORK IN CEMENT MORTAR (1:6)
 D.P.C.....25 D.P.C. IN CEMENT CONCRETE (1:2:4)
 FLOOR.....25 I.P.S. OVER 75 P.C.C.
 ROOF.....100 THK. R.C.C. ROOF (1:1.5:3)
 LINTEL.....150 THK. R.C.C. LINTEL (1:1.5:3)
 STAIRS.....RISE- 150, TREAD- 250

DETAILS OF AREA

TOTAL AREA (AS PER DEED)	81.78 SQM.
TOTAL AREA (AS PER SITE)	81.75 SQM.
GROUND FLOOR AREA	49.27 SQM.
FIRST FLOOR AREA	49.27 SQM.
TOTAL COVERED AREA	98.54 SQM.
% PLINTH AREA	60.26 %
FAR	1.20

SCHEDULE

D = 1.200X2.100	W = 1.800X1.200
D1 = 1.050X2.100	V2 = 2.400X1.200
D2 = 0.900X2.100	V = 0.600X0.600

TITLE OF DRAWING

PLAN OF PROPOSED RESIDENTIAL BUILDING OF SRI DIPAK BANERJEE S/O SRI ALOK BANERJEE OF FLAT NO. 1D BLOCK 'B' VASTU BIHAR, PHASE 1 KOLAKUSMA, DHANBAD, UNDER MOUZA - KOLAKUSMA, NO.- 12, KHATA NO.-30 NEW KHATA NO.- 600, PLOT NO.- 1723 NEW PLOT NO.- 2298 IN THE DIST. OF DHANBAD (JHARKHAND).

SIGNATURE OF OWNER

SIGNATURE OF ENGINEER

SCALE ALL DIMENSION ARE IN METRE

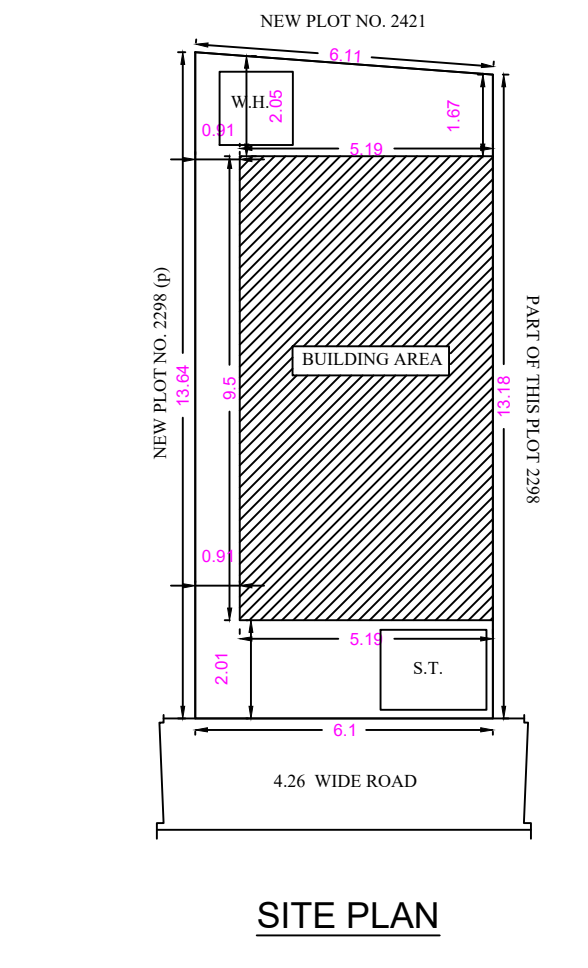
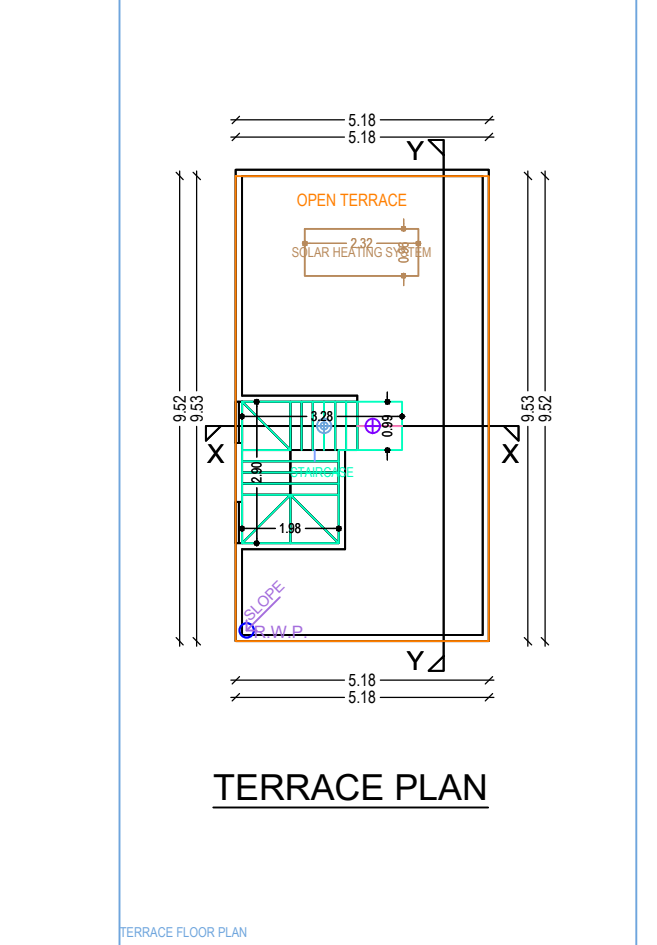
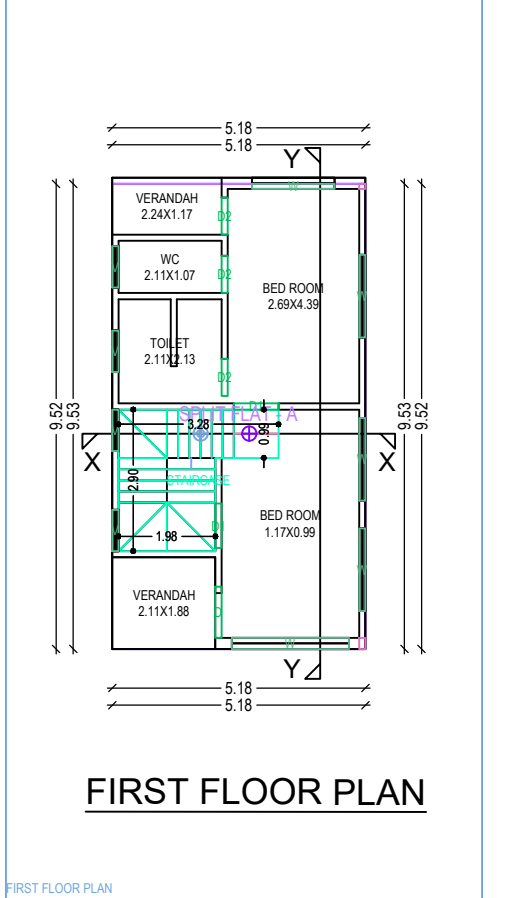
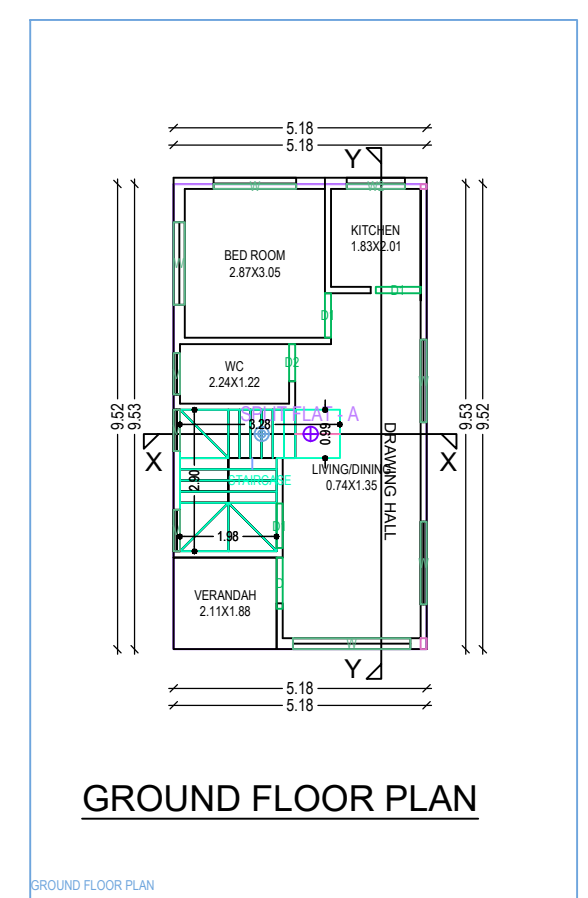
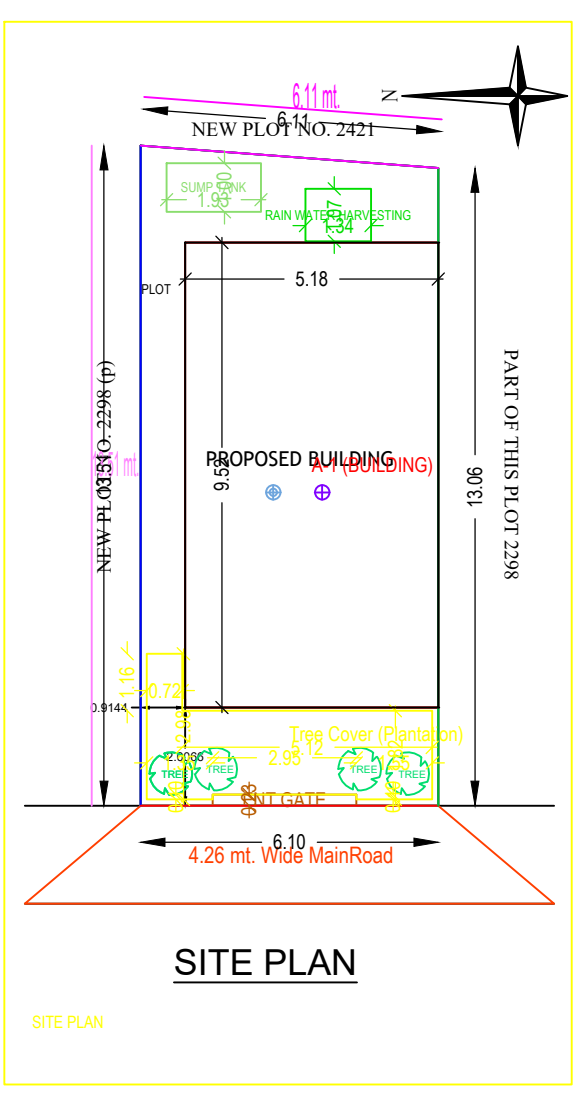

Building A (BUILDING)

Floor Name	Total Built Up Area (Sq.Mt)	Proposed FAR Area (Sq.Mt)	Total FAR Area (Sq.Mt)	Trent (No.)
Ground Floor	49.27	49.27	49.27	01
First Floor	49.27	49.27	49.27	01
Terrace Floor	0.00	0.00	0.00	01
Total	98.54	98.54	98.54	03

SCHEDULE OF JOINERY:

BUILDING NAME	NAME	LENGTH	HEIGHT	NOS
A (BUILDING)	G2	0.76	2.10	04
A (BUILDING)	G3	0.91	2.10	03
A (BUILDING)	G	1.00	2.10	02
Total	-	-	-	11

SCHEDULE OF JOINERY:

BUILDING NAME	NAME	LENGTH	HEIGHT	NOS
A (BUILDING)	W1	0.85	1.00	07
A (BUILDING)	W2	1.19	1.20	01
A (BUILDING)	W	1.89	1.20	08
A (BUILDING)	W	2.40	1.20	02
Total	-	-	-	18

UnitBUA Table for Building A (BUILDING)

FLOOR	Name	UnitBUA Type	UnitBUA Area	Carpet Area	No. of Rooms	No. of Tenement
GROUND FLOOR PLAN	SPLIT FLAT - A	FLAT	98.54	98.63	5	1
Total	-	-	98.54	98.63	11	1

AREA STATEMENT DHANBAD MUNICIPAL CORPORATION

COMPARTMENT	VERSION NO.	VERSION DATE
1	1.0.29	16/10/2020

PROJECT DETAIL:

Project No.	Plot Use - Residential
Region	Plot Subdiv. - Mangalam Dwelling / Non-Apartment
District	DHANBAD
Application Type	General Proposal
Project Type	Building Permissage
Nature of Development	New
Location	Old Area
Site Location	NA
Village/Moosa Name	NA
Block No.	NA
Road/Street	NA

AREA DETAILS:

DESCRIPTION	SA	SQ.MT
Net Plot Area (Gross Plot Area)	(A-Deductions)	80.98
Deduction from Gross Plot Area	(A-Deductions)	11.15
Net Plot Area (Net Plot Area)	(A-Deductions)	69.83
Total	(A-Deductions)	69.83
Proposed Coverage Area (60.26%)		42.06
Total Coverage Area (60.26%)		42.06
Proposed Area of FAR		98.54
Total Area of FAR		98.54
Total Proposed Building Area		98.54
MOBT (ENCL) SUPERSEDED (Page)		OWNER
DEVELOPMENT AUTHORITY		LOCAL BODY

COLOR INDEX

FLAT BOUNDARY	Black
ABUTTING ROAD	Green
PROPOSED WORKING COVERAGE AREA	Red
EXISTING (To be retained)	Blue
EXISTING (To be demolished)	Yellow

MARGIN DETAIL:

Building Name	Road Name	Front Margin	Rear Margin	Side Margin	Sold Margin
A (BUILDING)	MediRoad	2.01	1.52	0.91	0.90

FAR & Tenement Details (Table 4c-1)

Building	No. of Same Bldg	Total Built Up Area (Sq.Mt)	Proposed FAR Area (Sq.Mt)	Total FAR Area (Sq.Mt)	Trent (No.)
A (BUILDING)	1	98.54	98.54	98.54	03