

Proposal Basic Information	
Proposal File No.	DMC/BP/0155/W22/2021
Owner Name	SRI AJIT KUMAR TEWARY
Khata No	OLD - 87 , NEW - 249
Plot No	OLD - 1705 , 1713 , NEW - 2052
Village Name	Bhelaland
Use	Residential
SubUse	Bungalow/ Dwelling / Non Apartment

AREA STATEMENT		VERSION NO. : 1.0.61
DHANBAD MUNICIPAL CORPORATION		VERSION DATE: 16/10/2020
PROJECT DETAIL:		
Region: JHARKHAND URBAN LOCAL BODIES	Plot Use: Residential	
District: DHANBAD	Plot SubUse: Bungalow/ Dwelling / Non Apartment	
Authority: DHANBAD MUNICIPAL CORPORATION	PlotNearby/Religious/Structure: NA	
Inward No: DMC/BP/0155/W22/2021	Plot/SubPlot No: OLD - 1705 , 1713 , NEW - 2052	
Application Type: General Proposal	North: Plot No. - SOCIETY'S LAND MARKED AS PLOT NO - C/6	
Project Type: Building Permission	South: Plot No. - SOCIETY'S LAND MARKED AS PLOT NO - C/4	
Nature of Development: New	East: Road Width - 6.09 M WIDE ROAD	
Location of Development Area: Old Area	West: Plot No. - PORTION OF PLOT NO - 1705	
AREA DETAILS:		SQ.MT.
AREA OF PLOT (Minimum)	(A)	177.21
NET AREA OF PLOT(Gross Plot Area - Deduction from Gross Plot area)	(A-Deductions)	177.21
Deduction for Balance Plot Area(from Gross Plot Area)		
Common Plot		12.56
Total		12.56
BALANCE AREA OF PLOT(Net Plot Area - Recreational/Amenity space)	(A-Deductions)	164.65
PLOT AREA FOR COVERAGE(Net Plot Area)	(A-Deductions)	177.21
Plot Area for FAR (Net Plot Area + Road Widening Area)	(A-Deductions)	177.21
COVERAGE CHECK		
Permissible Coverage area (70.00 %)		124.05
Proposed Coverage Area (52.15 %)		92.41
Total Prop. Coverage Area (52.15 %)		92.41
Balance coverage area (17.85 %)		31.64
FAR CHECK		
Perm. FAR Area (1.50)		265.82
Total Perm. FAR area		265.82
Residential FAR		203.09
Proposed FAR Area		203.09
Total Proposed FAR Area		203.09
Consumed FAR (Factor)		1.15
Balance FAR Area		62.73
BUILT UP AREA CHECK		
Total Proposed BuiltUp Area		203.08
ARCHITECT (Regd)		
ARCHITECT (Regd)		AMARENDRA KUMAR
ENGINEER (Regd)		
ENGINEER (Regd)		SRI AJIT KUMAR TEWARY
SUPERVISOR (Regd)		
SUPERVISOR (Regd)		SRI AJIT KUMAR TEWARY
OWNER (Regd)		
OWNER (Regd)		SRI AJIT KUMAR TEWARY
DEVELOPMENT AUTHORITY		
DEVELOPMENT AUTHORITY		LOCAL BODY

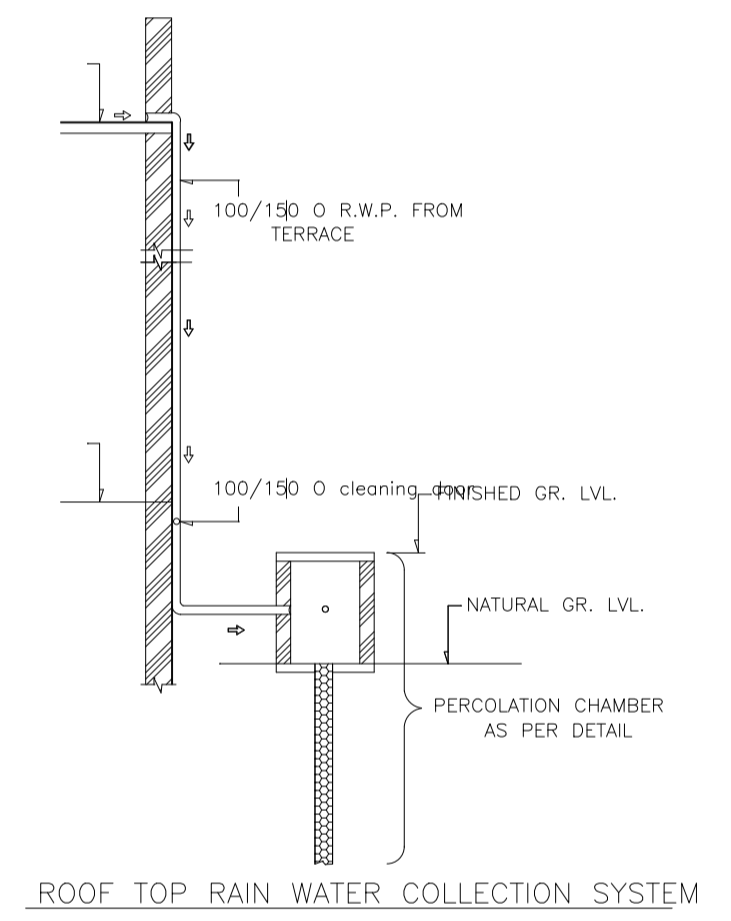
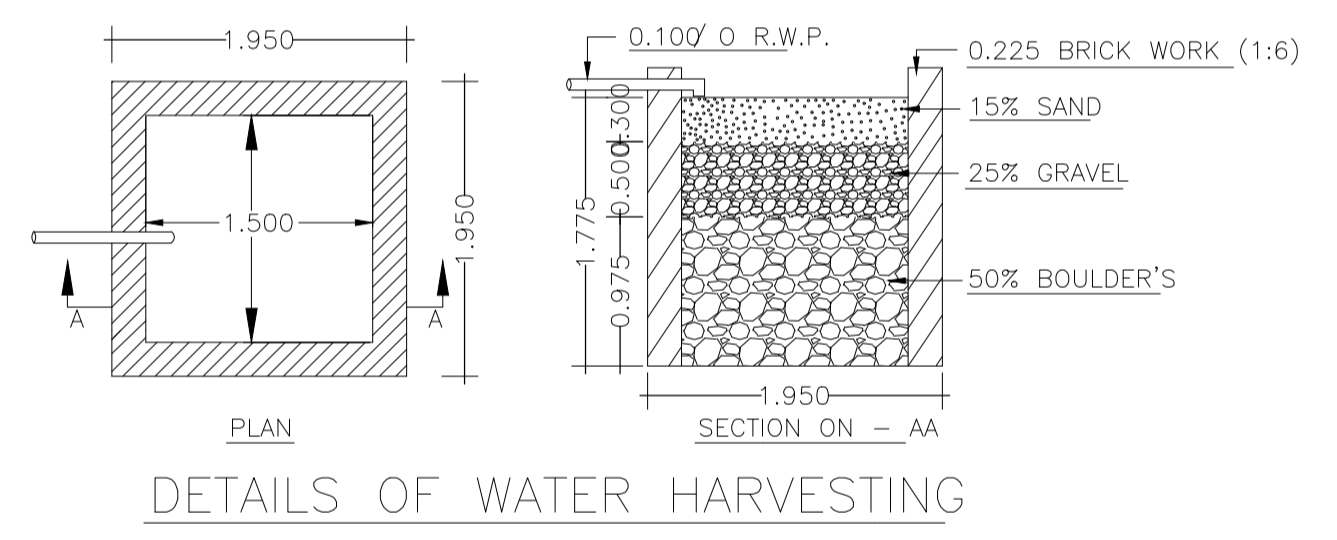
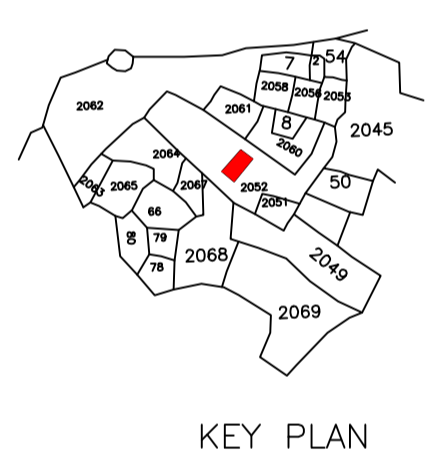
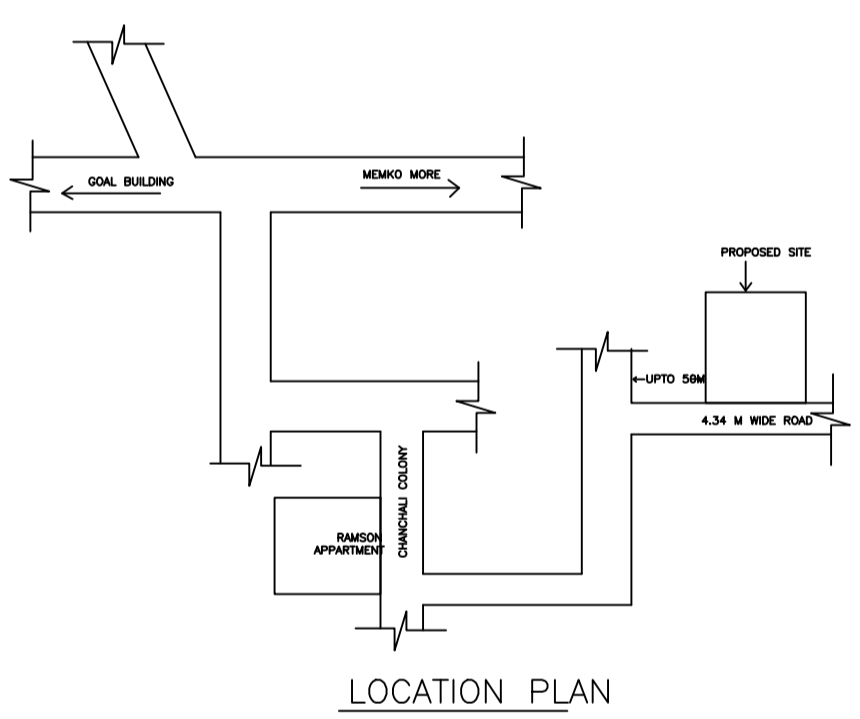

COLOR INDEX	
PLOT BOUNDARY	Black
ABUTTING ROAD	Green
PROPOSED CONSTRUCTION	Red
COMMON PLOT	Yellow
ROAD WIDENING AREA	Orange
EXISTING (To be retained)	Blue
EXISTING (To be demolished)	Light Blue

SCHEDULE OF DOOR:

BUILDING NAME	NAME	LENGTH	HEIGHT	NOS
AA (BB)	D	0.76	2.10	09
AA (BB)	D	0.91	2.10	02
AA (BB)	D	1.07	2.10	08

SCHEDULE OF WINDOW/VENTILATION:

BUILDING NAME	NAME	LENGTH	HEIGHT	NOS
AA (BB)	W	0.61	1.20	04
AA (BB)	W	0.91	1.20	04
AA (BB)	W	0.92	1.20	01
AA (BB)	W	1.22	1.20	01
AA (BB)	W	1.52	1.20	07
AA (BB)	W	1.53	1.20	01
AA (BB)	W	2.36	1.20	01

Building :AA (BB)

Floor Name	Total Built Up Area (Sq.mt.)	Proposed FAR Area (Sq.mt.) Res.	Total FAR Area (Sq.mt.)	Total Consumed Additional FAR Area (Sq.mt.)	Tnmt (No.)
Ground Floor	92.41	92.41	92.41	92.41	01
First Floor	110.67	110.67	110.67	110.67	00
Terrace Floor	0.00	0.00	0.00	0.00	00
Total :	203.08	203.08	203.08	203.08	01
Total Number of Same Buildings	1				
Total :	203.08	203.08	203.08	203.08	01

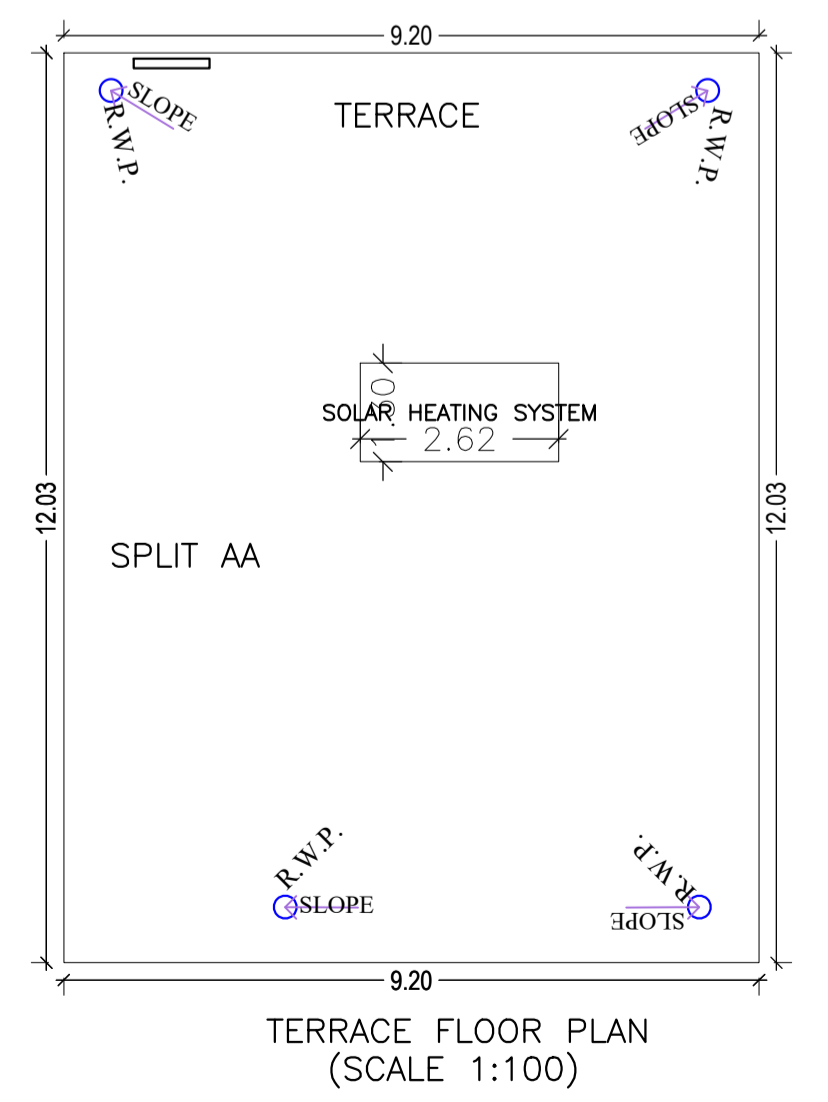
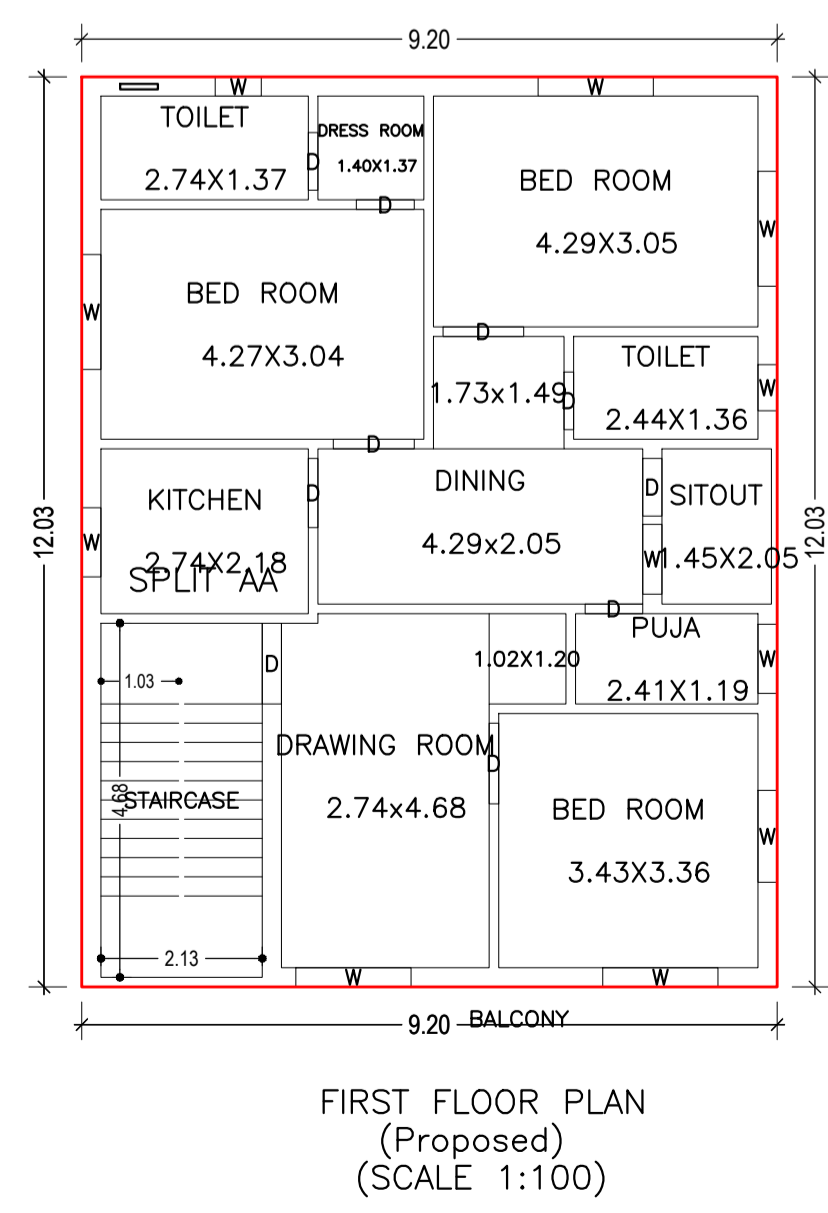
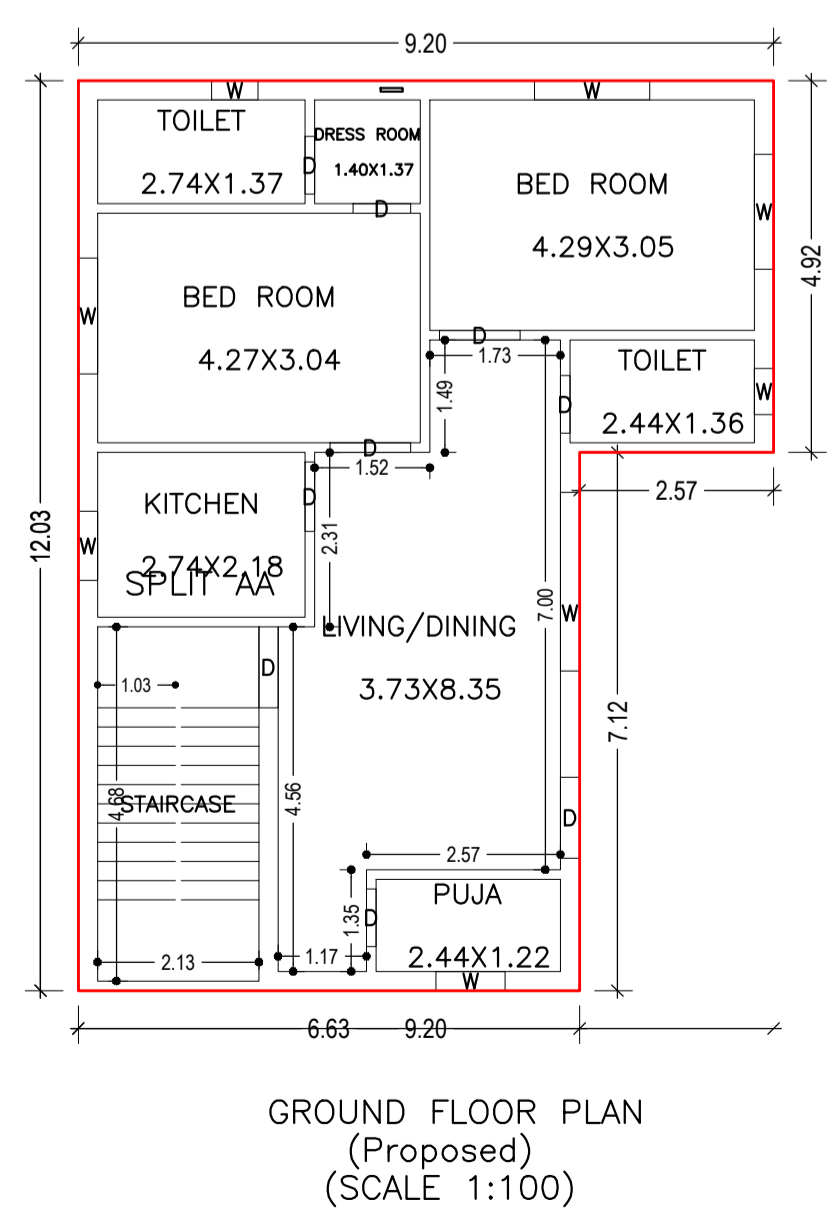

Floor Name	Building Name		Total	
	Proposed Built Up Area (Sq.mt.)	Proposed FAR Area (Sq.mt.)	Total Proposed Built Up Area (Sq.mt.)	Total FAR Area (Sq.mt.)
Ground Floor	92.41	92.41	92.41	92.41
First Floor	110.67	110.67	110.67	110.67
Terrace Floor	0.00	0.00	0.00	0.00
Total :	203.08	203.08	203.08	203.08

Building Name	Building Use	Building SubUse	Building Structure
AA (BB)	Residential	Bungalow/ Dwelling / Non Apartment	Non-Highrise

FAR & Tenement Details (Table 4c-1)

Building	No. of Same Bldg	Total Built Up Area (Sq.mt.)	Proposed FAR Area (Sq.mt.) Res.	Total FAR Area (Sq.mt.)	Total Consumed Additional FAR Area (Sq.mt.)	Tnmt (No.)
AA (BB)	1	203.08	203.08	203.08	203.08	01
Grand Total :	1	203.08	203.08	203.08	203.08	01

UnitBUA Table for Building :AA (BB)

FLOOR	Name	UnitBUA Type	UnitBUA Area	Carpet Area	No. of Rooms	No. of Tenement
GROUND FLOOR PLAN	SPLIT AA	FLAT	203.09	203.04	8	1
FIRST FLOOR PLAN	SPLIT AA	FLAT	0.00	0.00	11	0
Total:	-	-	203.09	203.04	19	1

LTP NAME AND SIGNATURE	STRUCTURAL ENG'S NAME AND SIGNATURE	BUILDER NAME AND SIGNATURE	DIGITAL SIGNATURE
AMARENDRA KUMAR DMC/ENG/0009/2016			

Proposal Basic Information	
Proposal File No.	DMC/BP/0155/W22/2021
Owner Name	SRI AJIT KUMAR TEWARY
Khata No	OLD - 87 , NEW - 249
Plot No	OLD - 1705 , 1713 , NEW - 2052
Village Name	Bhelaland
Use	Residential
SubUse	Bungalow/ Dwelling / Non Apartment

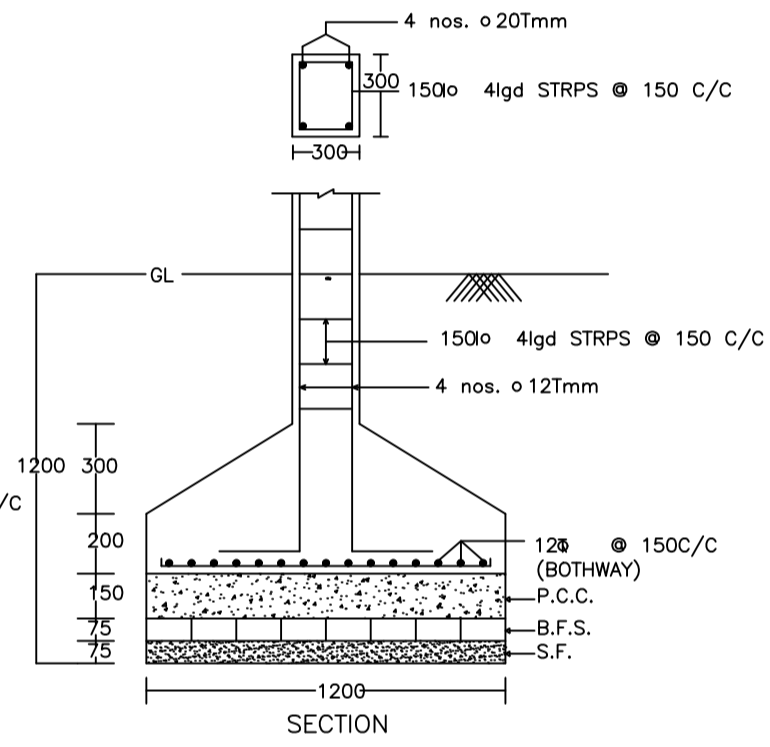
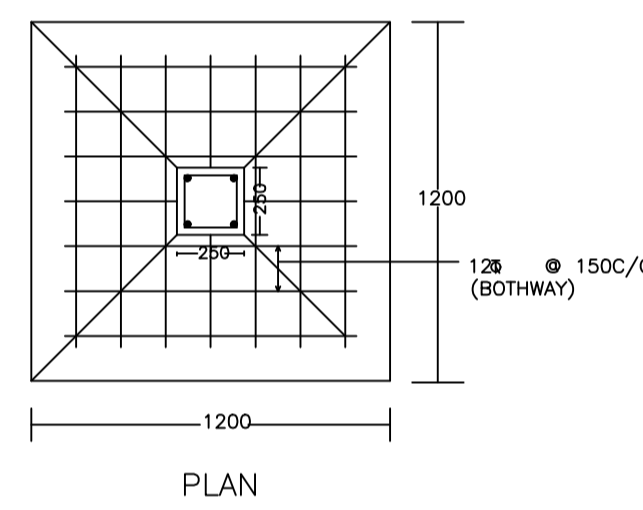
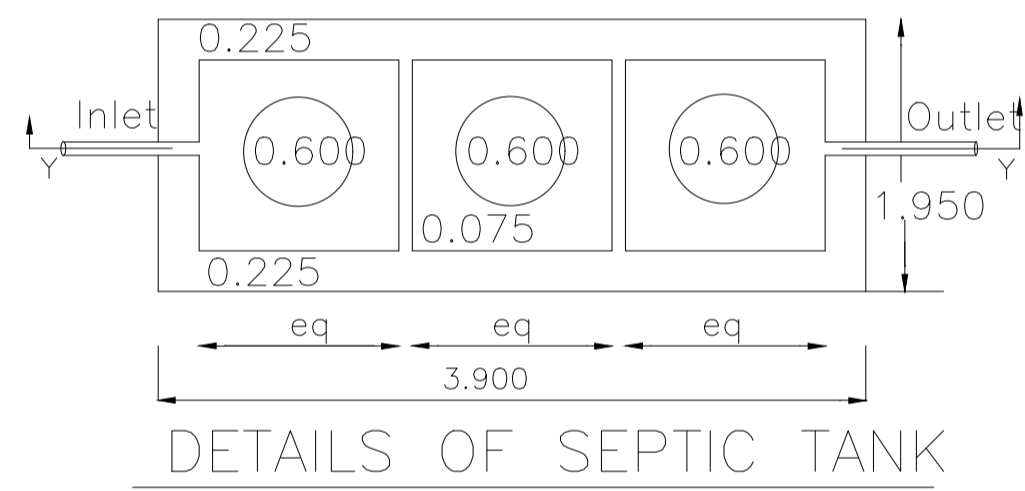
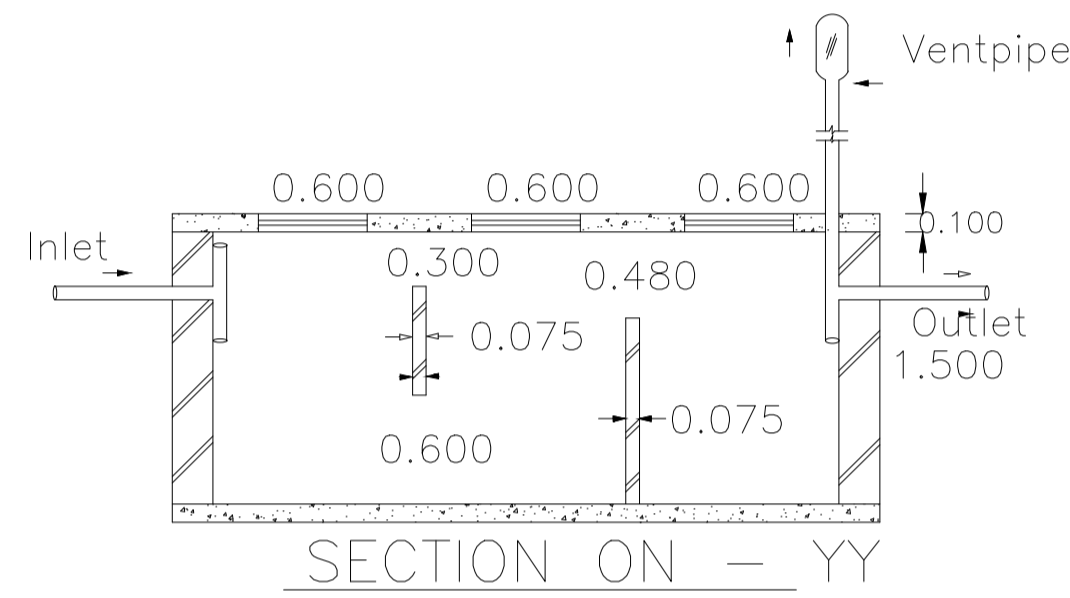
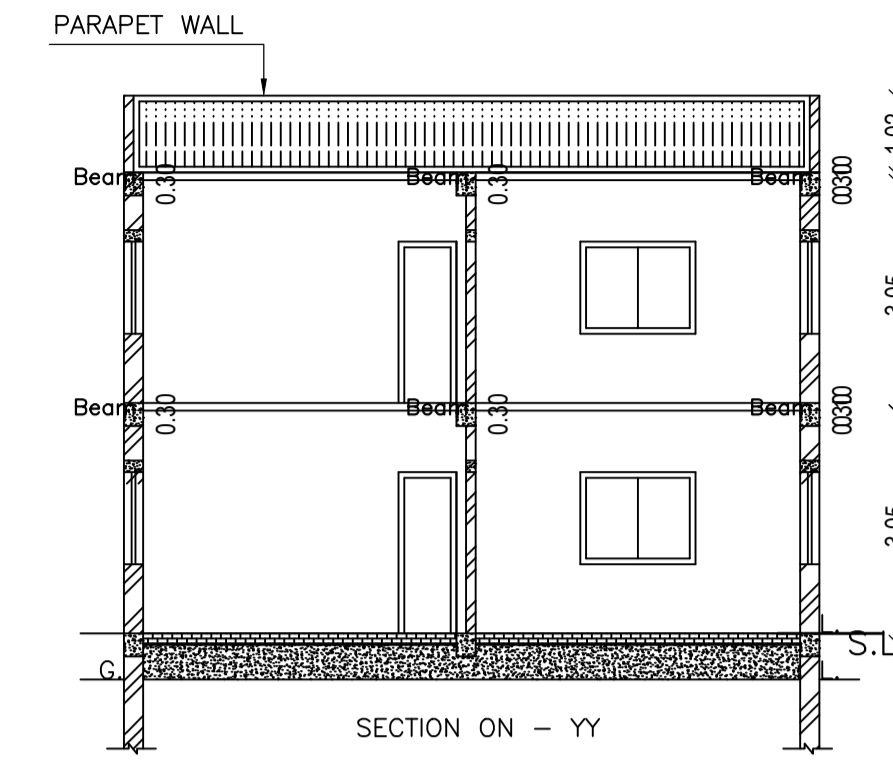
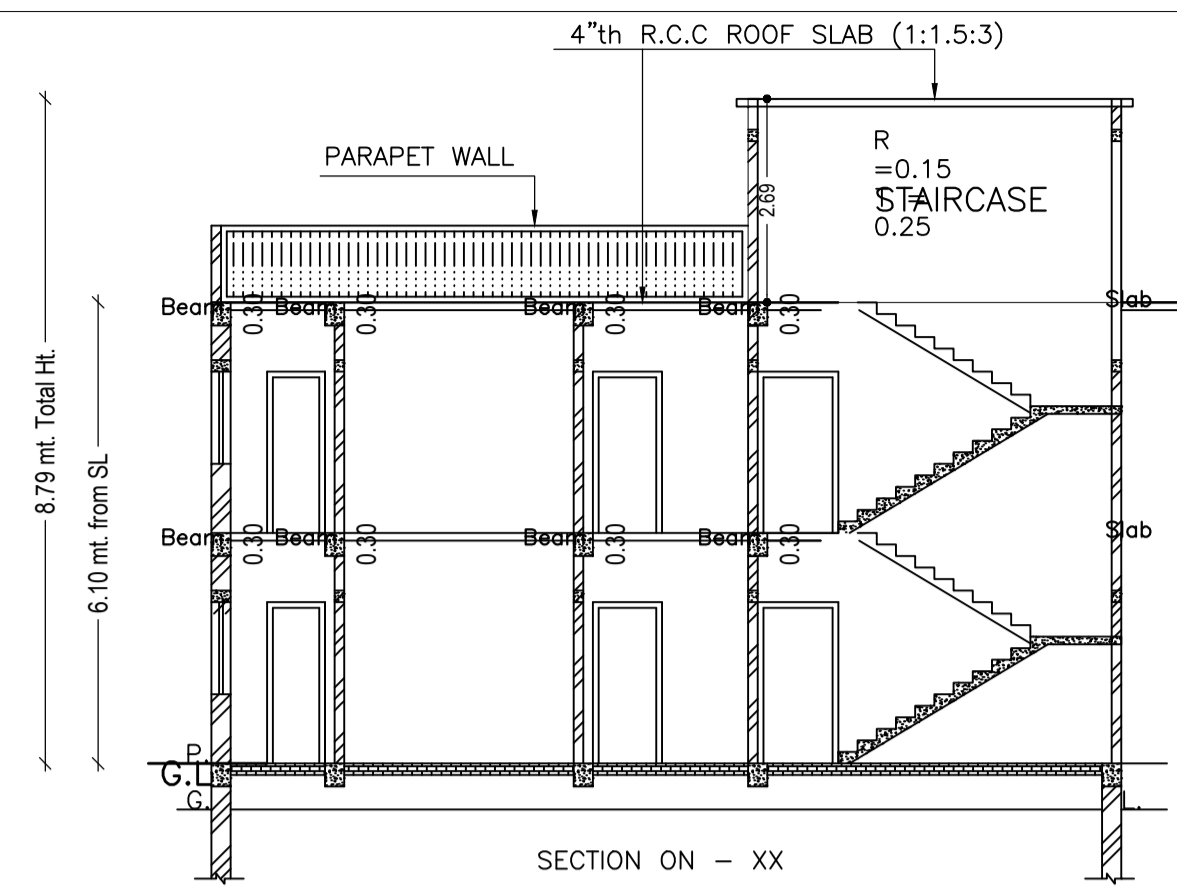
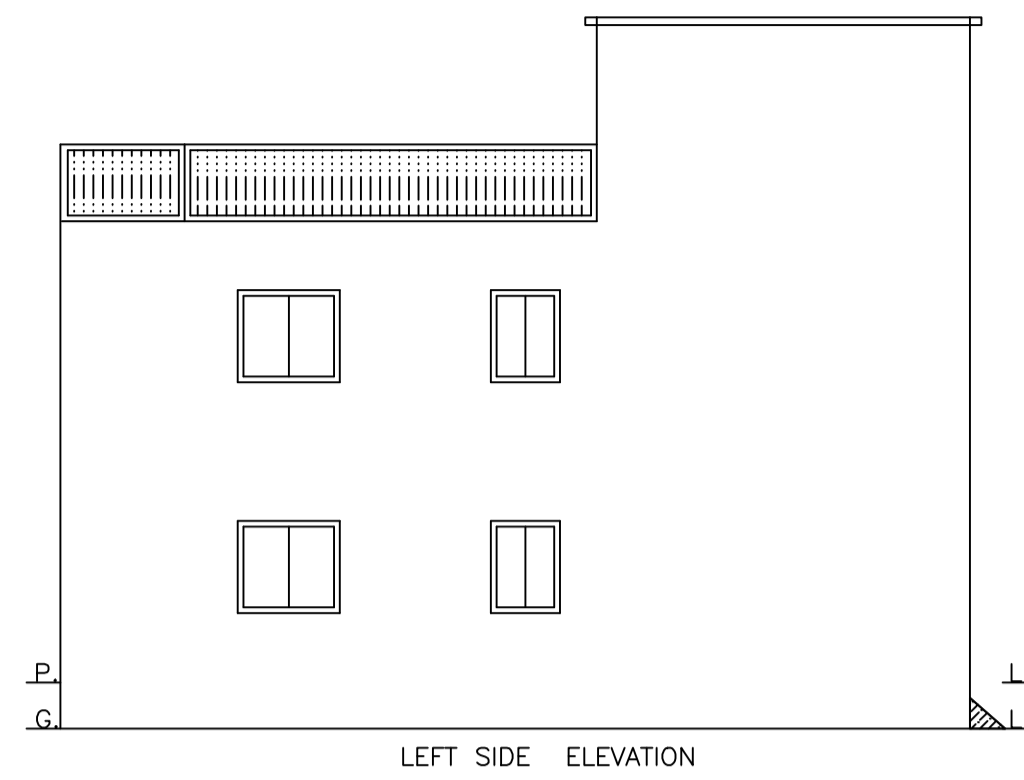
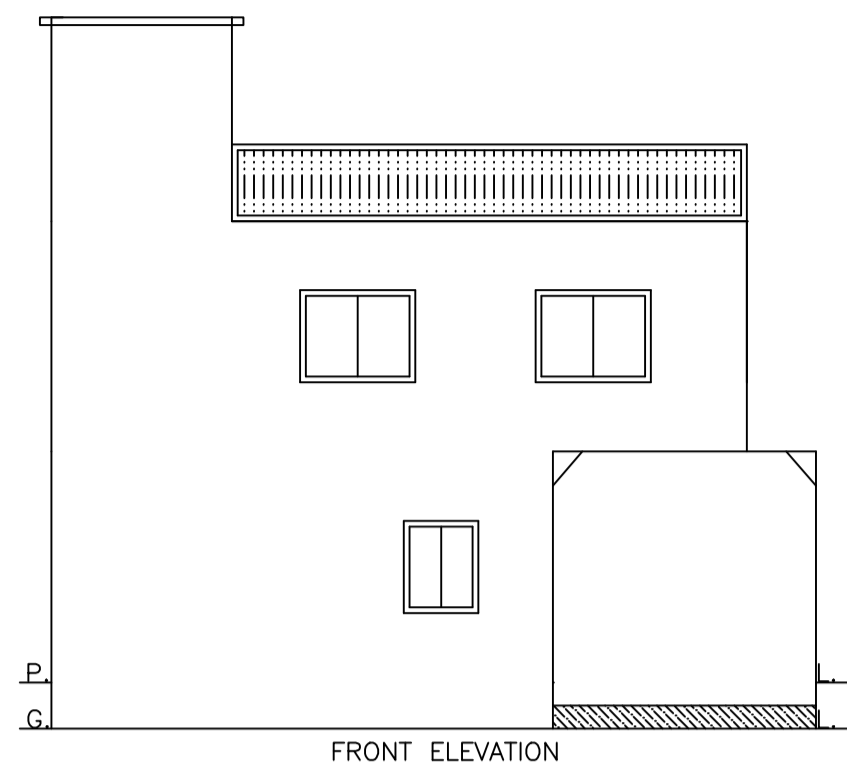

DETAIL OF COLUMNS

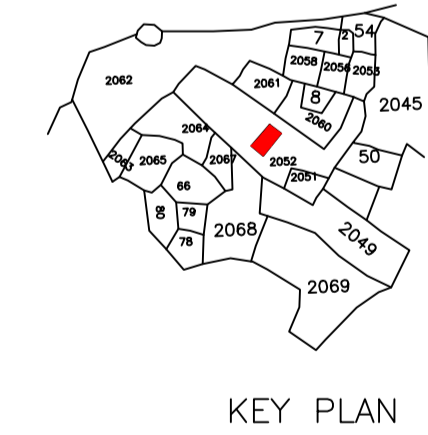
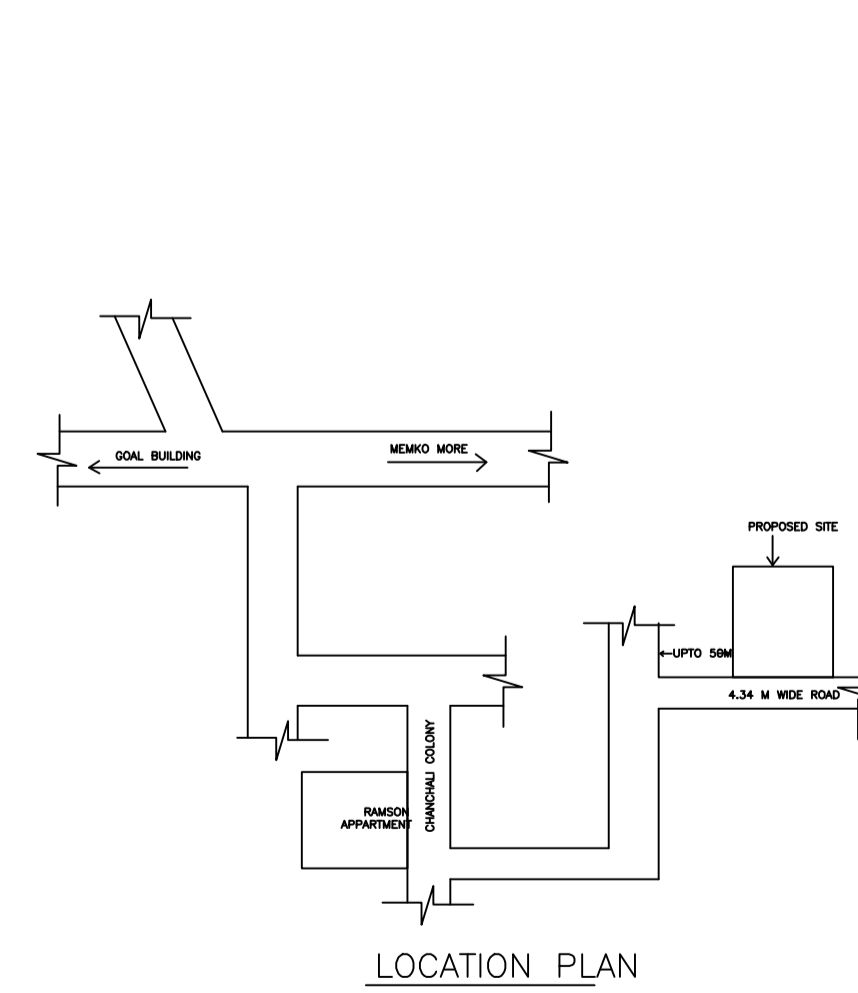
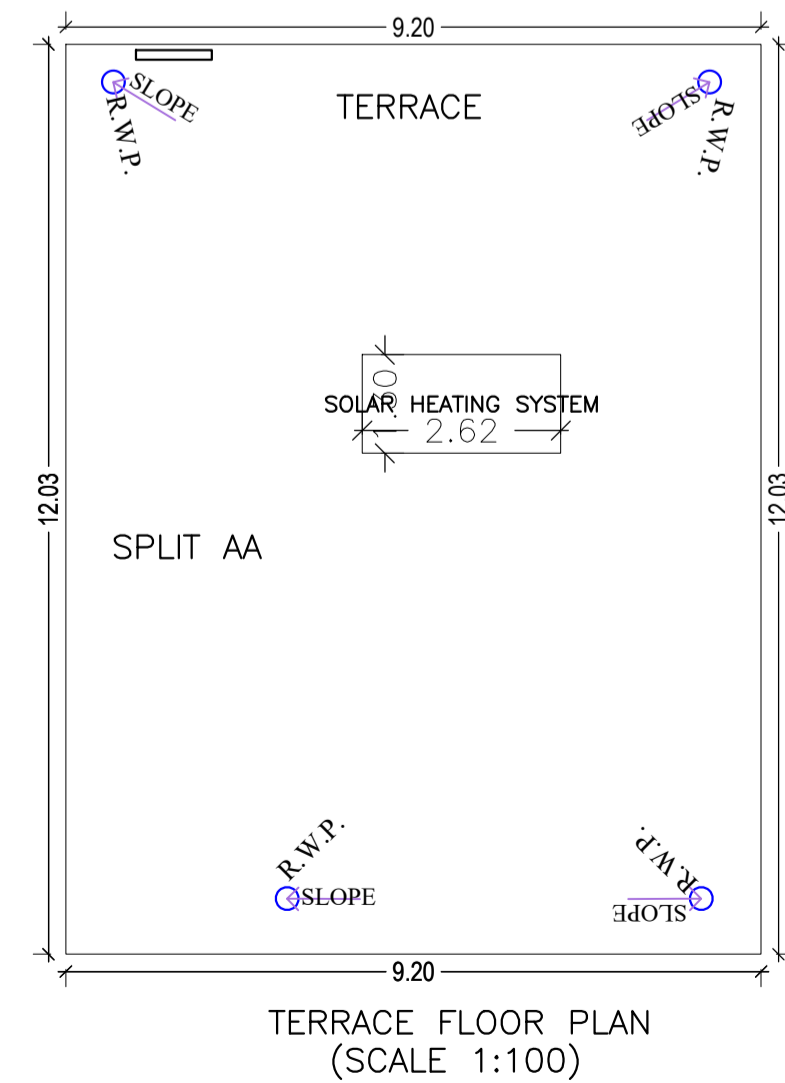
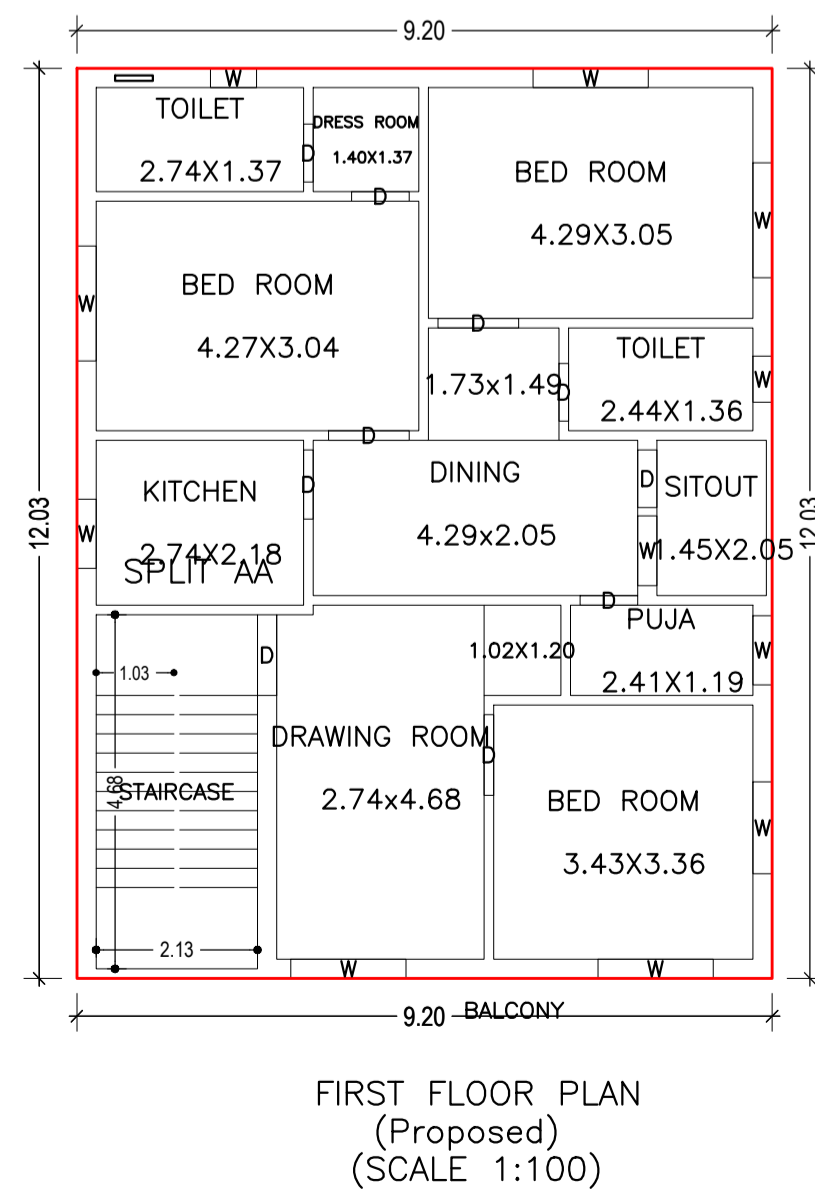
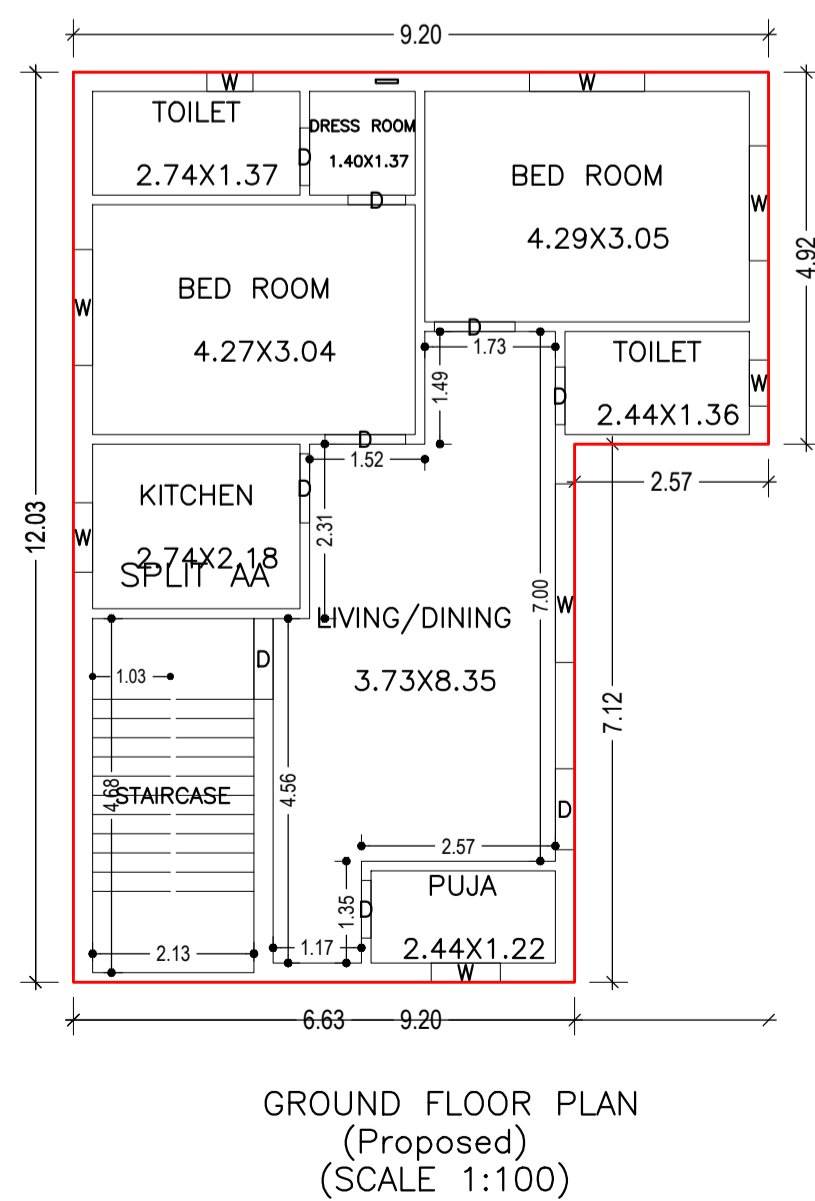
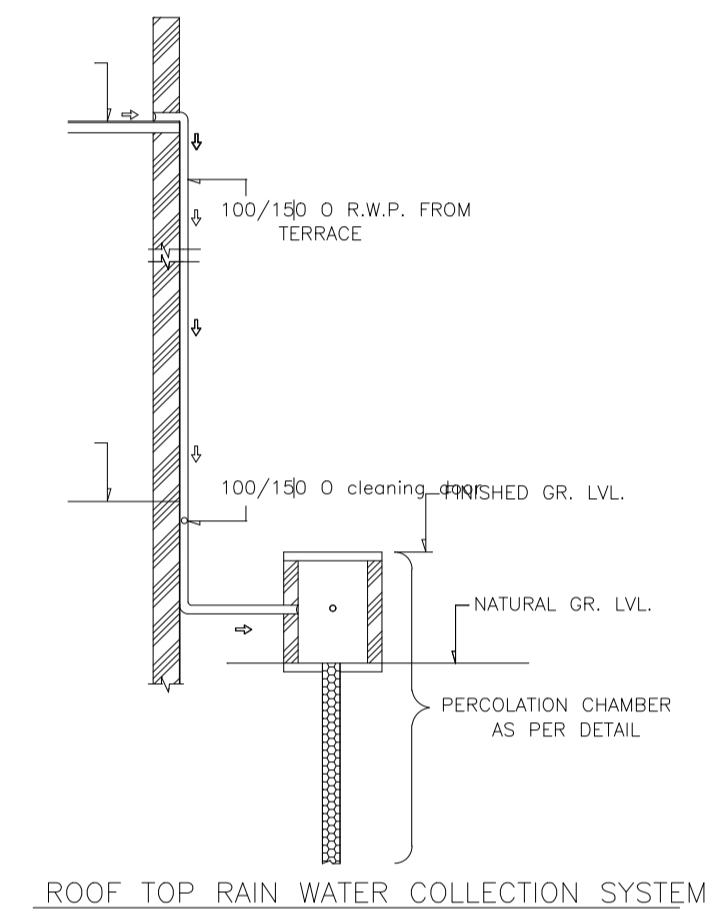
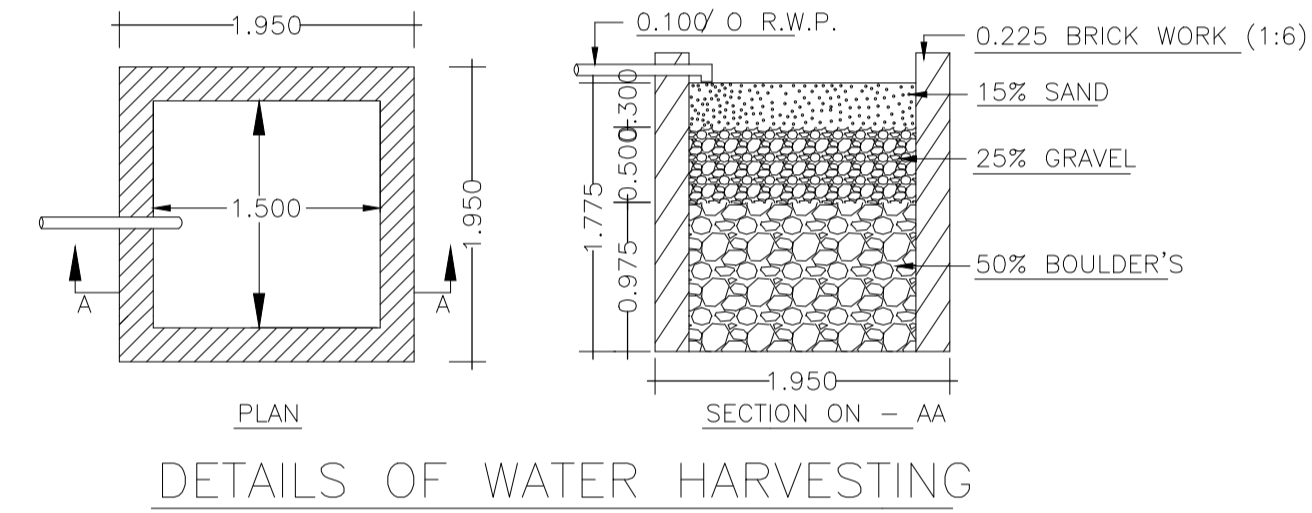

LTP NAME AND SIGNATURE	STRUCTURAL ENG'S NAME AND SIGNATURE	BUILDER NAME AND SIGNATURE	DIGITAL SIGNATURE
AMARENDRA KUMAR DMC/ENG/0009/2016			