

Proposal Basic Information	
Proposal File No.	DMC/BP/0233/W23/2021
Owner Name	SRI. RAMJI SINGH YADAV.
Khata No	30 ( Old ), 600 ( New )
Plot No	1723 ( Old ), 2298 ( New )
Village Name	Kolakusma
Use	Residential
SubUse	Bungalow/ Dwelling / Non Apartment

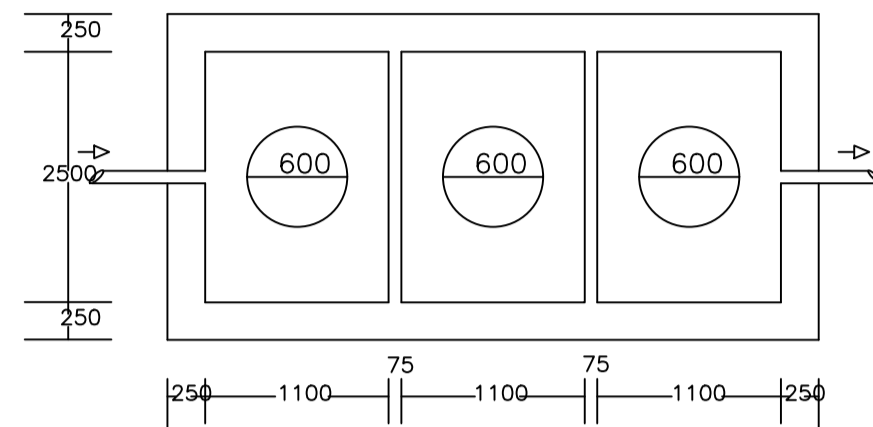

PLAN OF SEPTIC TANK

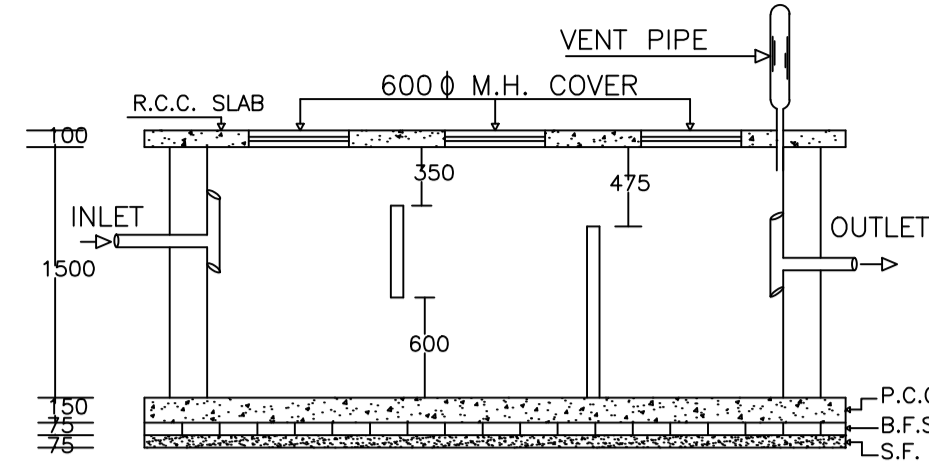
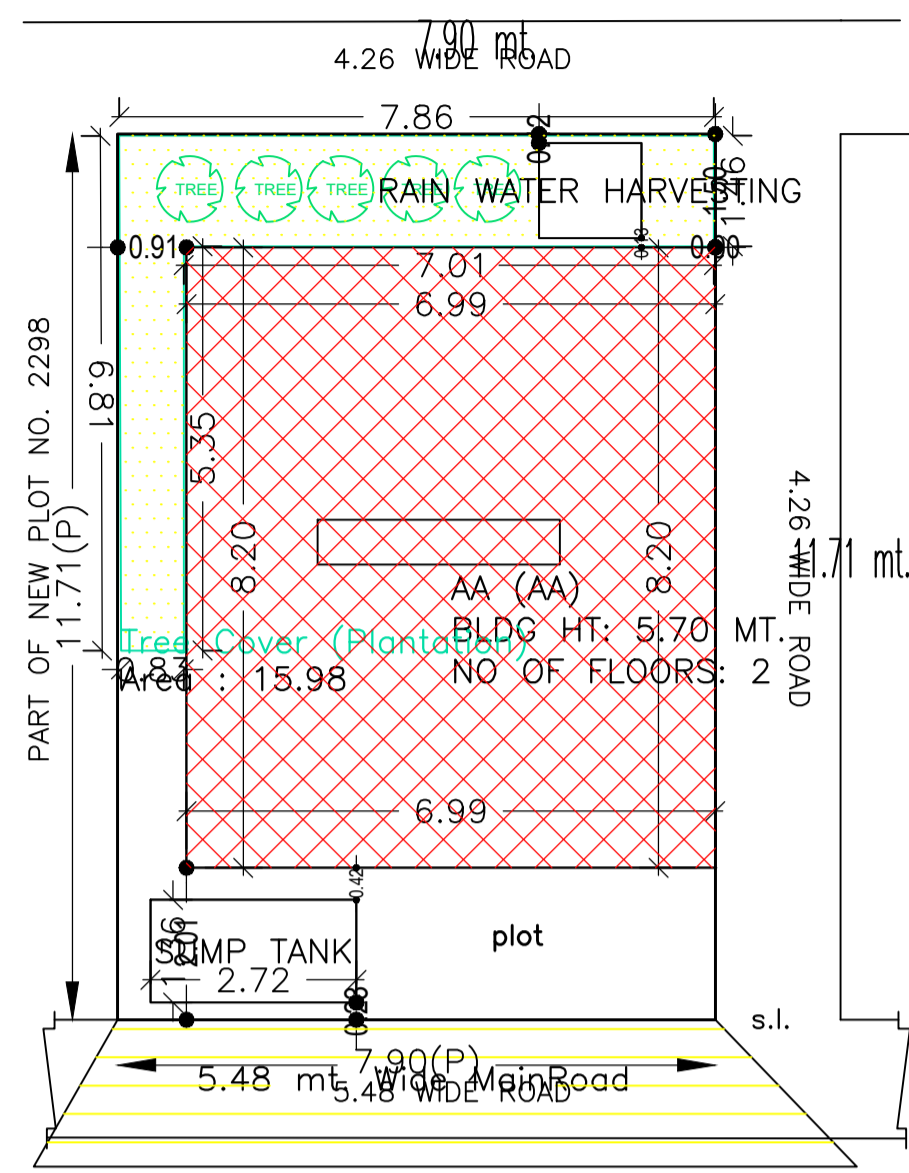
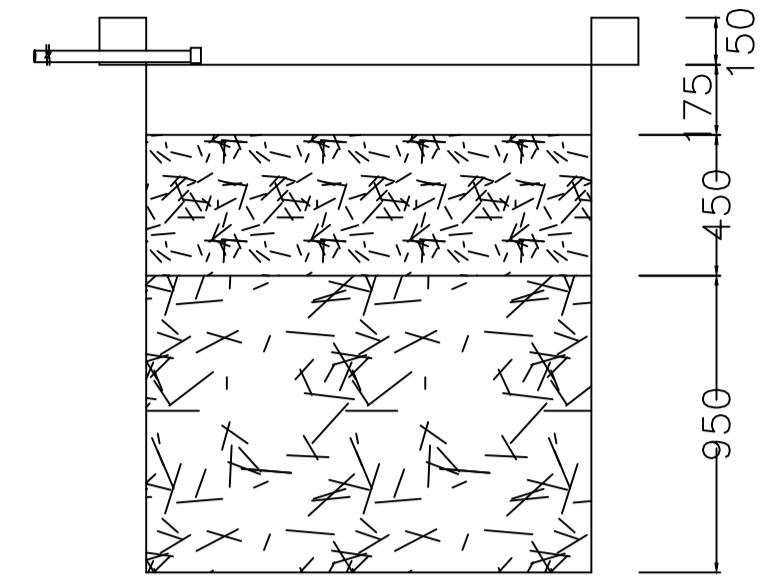

SECTION AT Y-Y

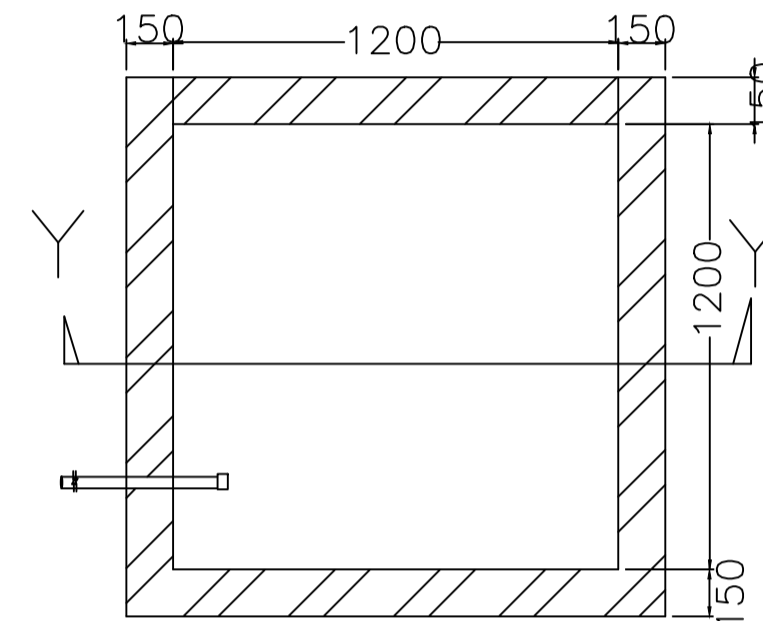

PLAN OF RECHARGE WELL  
WATER HARVESTING

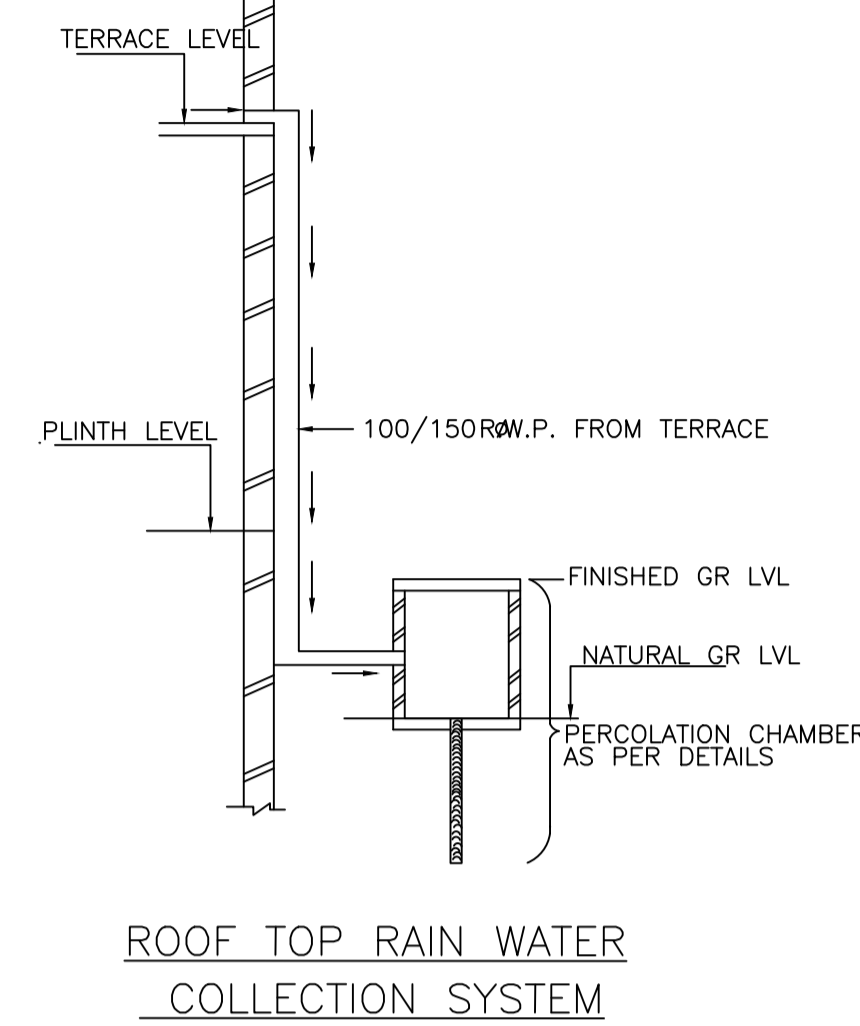

ROOF TOP RAIN WATER  
COLLECTION SYSTEM

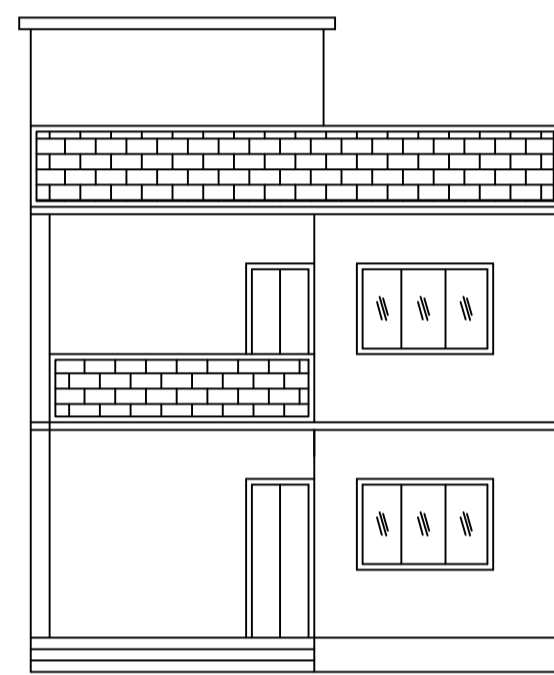

FRONT ELEVATION

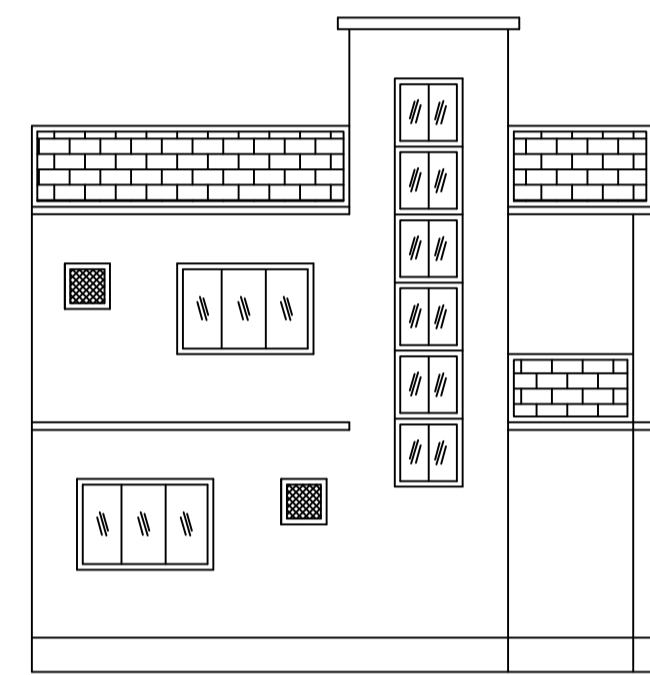

LEFT SIDE ELEVATION

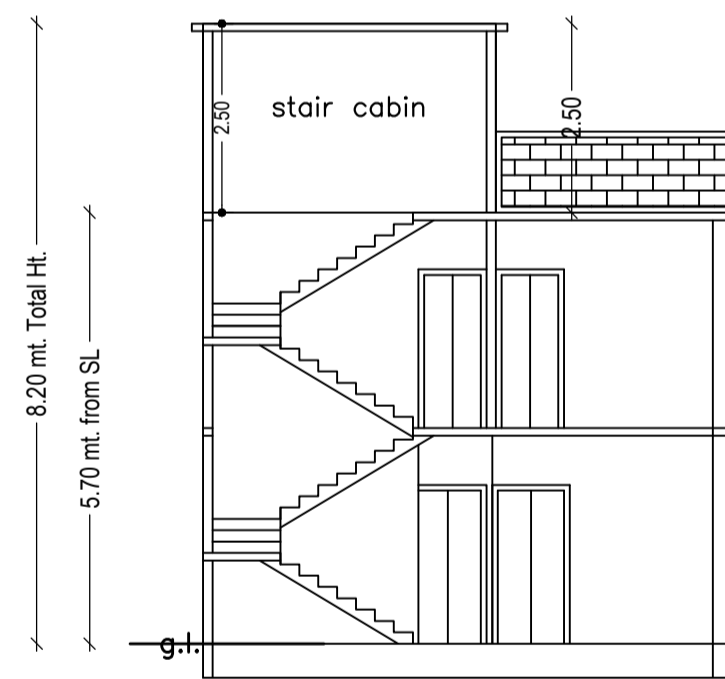

SECTION ON X-X

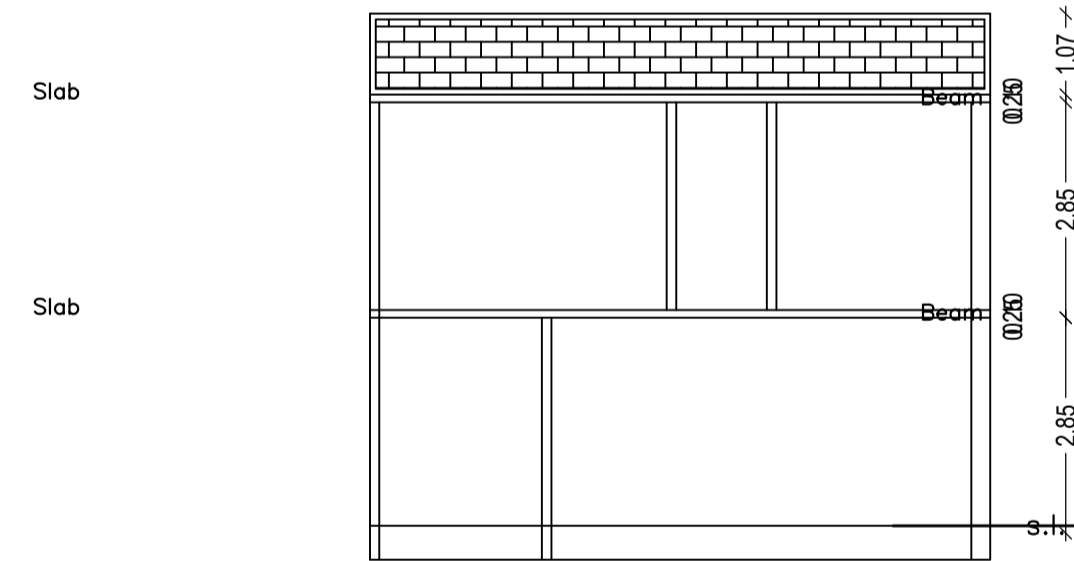

SECTION ON Y-Y

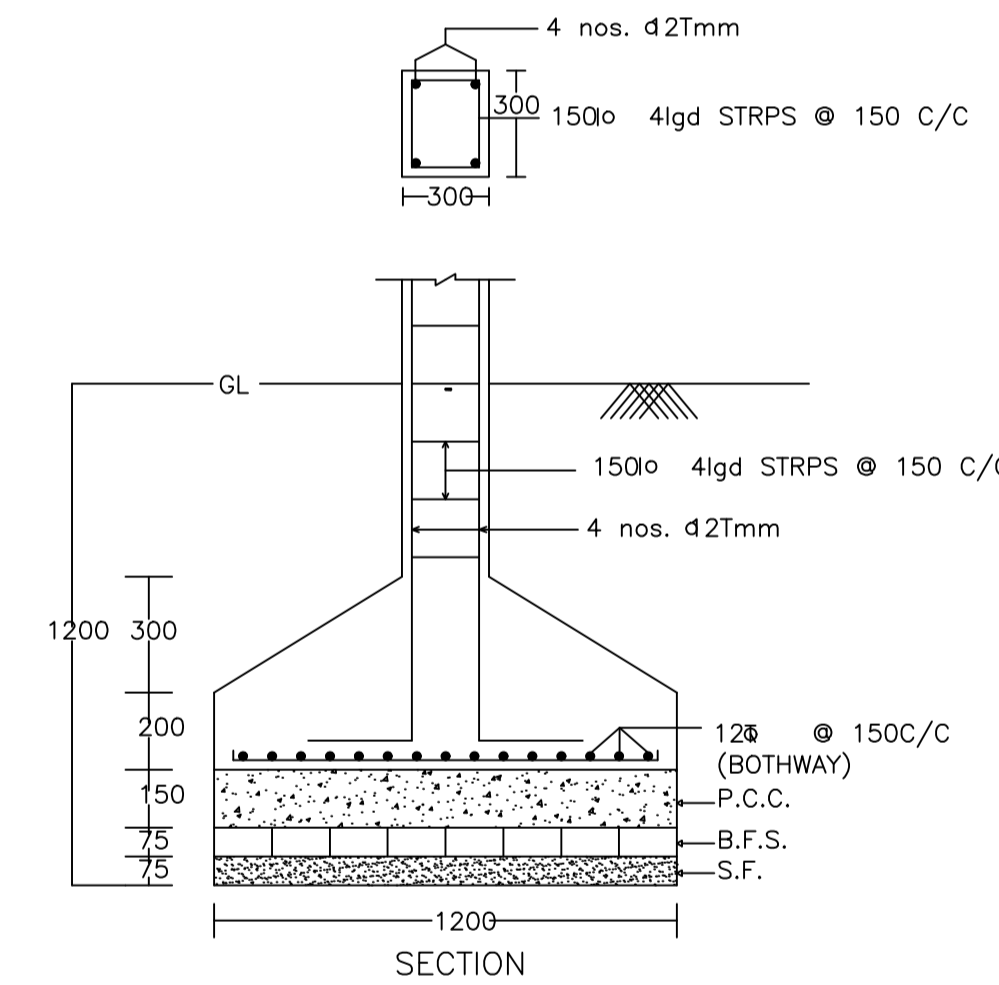

SECTION

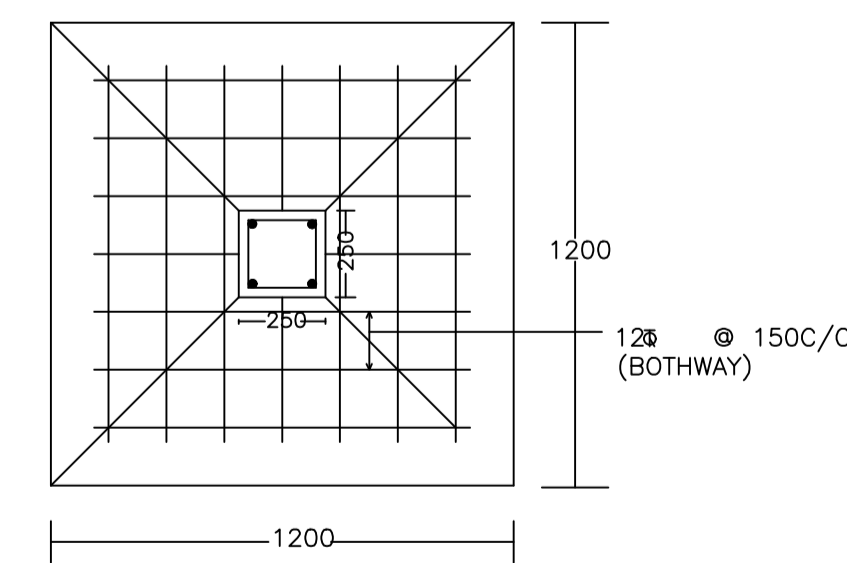

PLAN

DETAIL OF COLUMNS

AREA STATEMENT		VERSION NO.:	1.0.61
DHANBAD MUNICIPAL CORPORATION		VERSION DATE: 16/10/2020	
PROJECT DETAIL:			
Region: JHARKHAND URBAN LOCAL BODIES	Plot Use: Residential		
District: DHANBAD	Plot SubUse: Bungalow/ Dwelling / Non Apartment		
Authority: DHANBAD MUNICIPAL CORPORATION	PlotNearby/ReligiousStructure: NA		
Inward No: DMC/BP/0233/W23/2021	Plot/SubPlot No: 1723 ( Old ), 2298 ( New )		
Application Type: General Proposal	North: Plot No. - PART OF NEW PLOT NO. 2298		
Project Type: Building Permission	South: Road Width - ROAD		
Nature of Development: New	East: Road Width - ROAD		
Location of Development Area: Old Area	West: Road Width - 5.48		
AREA OF PLOT (Minimum)	(A)	SQ.MT.	92.60
NET AREA OF PLOT (Gross Plot Area - Deduction from Gross Plot area)	(A-Deductions)		92.60
Deduction for Balance Plot Area (from Gross Plot Area)			
Common Plot			15.98
Total			15.98
BALANCE AREA OF PLOT (Net Plot Area - Recreational/Amenity space)	(A-Deductions)		76.62
PLOT AREA FOR COVERAGE (Net Plot Area)	(A-Deductions)		92.60
Plot Area for FAR (Net Plot Area + Road Widening Area)	(A-Deductions)		92.60
COVERAGE CHECK			
Permissible Coverage area ( 70.00 % )			64.82
Proposed Coverage Area ( 61.97 % )			57.39
Total Prop. Coverage Area ( 61.97 % )			57.39
Balance coverage area ( 8.02 % )			7.43
FAR CHECK			
Perm. FAR Area ( 1.80 )			166.68
Total Perm. FAR area			166.68
Residential FAR			114.78
Proposed FAR Area			114.78
Total Proposed FAR Area			114.78
Consumed FAR (Factor)			1.24
Balance FAR Area			51.90
BUILT UP AREA CHECK			
Total Proposed BuiltUp Area			114.78
ARCHITECT (Regd)	PARTHA - PAL		
ENGINEER (Regd)			
SUPERVISOR (Regd)			
OWNER (Regd)	SRI. RAMJI SINGH YADAV.		
DEVELOPMENT AUTHORITY		LOCAL BODY	

COLOR INDEX	
PLOT BOUNDARY	Black
ABUTTING ROAD	Green
PROPOSED CONSTRUCTION	Red
COMMON PLOT	Yellow
ROAD WIDENING AREA	Orange
EXISTING (To be retained)	Blue
EXISTING (To be demolished)	Light Blue

Buildingwise Floor FAR Details				
Floor Name	Building Name		Total	
	Proposed Built Up Area (Sq.mt.)	Proposed FAR Area (Sq.mt.)	Total Proposed Built Up Area (Sq.mt.)	Total FAR Area (Sq.mt.)
Ground Floor	57.39	57.39	57.39	57.39
First Floor	57.39	57.39	57.39	57.39
Terrace Floor	0.00	0.00	0.00	0.00
Total:	114.78	114.78	114.78	114.78

Building USE/SUBUSE Details			
Building Name	Building Use	Building SubUse	Building Structure
AA (AA)	Residential	Bungalow/ Dwelling / Non Apartment	Non-Highrise

FAR & Tenement Details (Table 4c-1)						
Building	No. of Same Bldg	Total Built Up Area (Sq.mt.)	Proposed FAR Area (Sq.mt.)	Total FAR Area (Sq.mt.)	Total Consumed Additional FAR Area (Sq.mt.)	Tnmt (No.)
AA (AA)	1	114.78	114.78	114.78	114.78	01
Grand Total:	1	114.78	114.78	114.78	114.78	01

UnitBUA Table for Building :AA (AA)						
FLOOR	Name	UnitBUA Type	UnitBUA Area	Carpet Area	No. of Rooms	No. of Tenement
GROUND FLOOR PLAN	SPLIT aa	FLAT	114.78	114.66	5	1
FIRST FLOOR PLAN	SPLIT aa	FLAT	0.00	0.00	7	0
Total:	-	-	114.78	114.66	12	1

SCHEDULE OF DOOR:				
BUILDING NAME	NAME	LENGTH	HEIGHT	NOS
AA (AA)	d	0.75	2.10	02
AA (AA)	d	0.90	2.10	07
AA (AA)	d	1.05	2.10	01

SCHEDULE OF WINDOW/VENTILATION:				
BUILDING NAME	NAME	LENGTH	HEIGHT	NOS
AA (AA)	w	0.60	1.20	03
AA (AA)	w	0.90	1.20	02
AA (AA)	w	1.80	1.20	06
AA (AA)	w	2.51	1.20	01

Building :AA (AA)					
Floor Name	Total Built Up Area (Sq.mt.)	Proposed FAR Area (Sq.mt.)	Total FAR Area (Sq.mt.)	Total Consumed Additional FAR Area (Sq.mt.)	Tnmt (No.)
Ground Floor	57.39	57.39	57.39	57.39	01
First Floor	57.39	57.39	57.39	57.39	00
Terrace Floor	0.00	0.00	0.00	0.00	00
Total:	114.78	114.78	114.78	114.78	01
Total Number of Same Buildings	1				
Total:	114.78	114.78	114.78	114.78	01

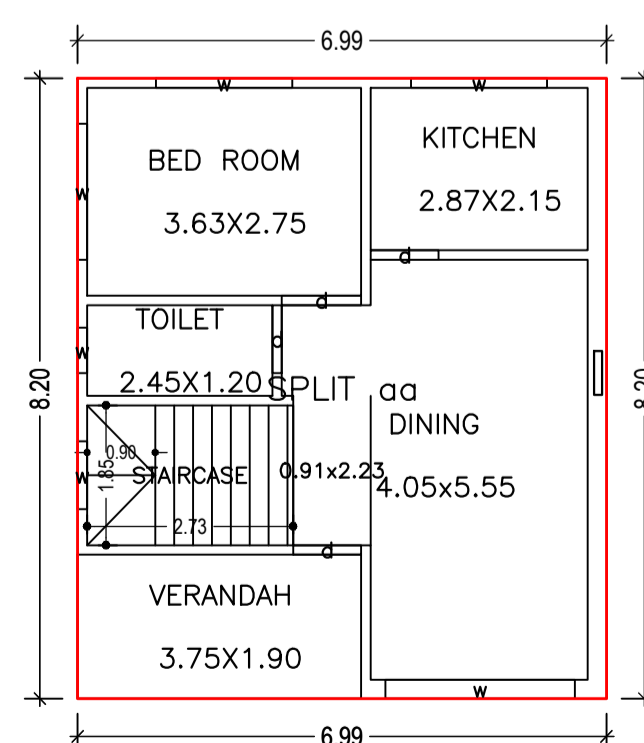

GROUND FLOOR PLAN  
(Proposed)  
(SCALE 1:100)

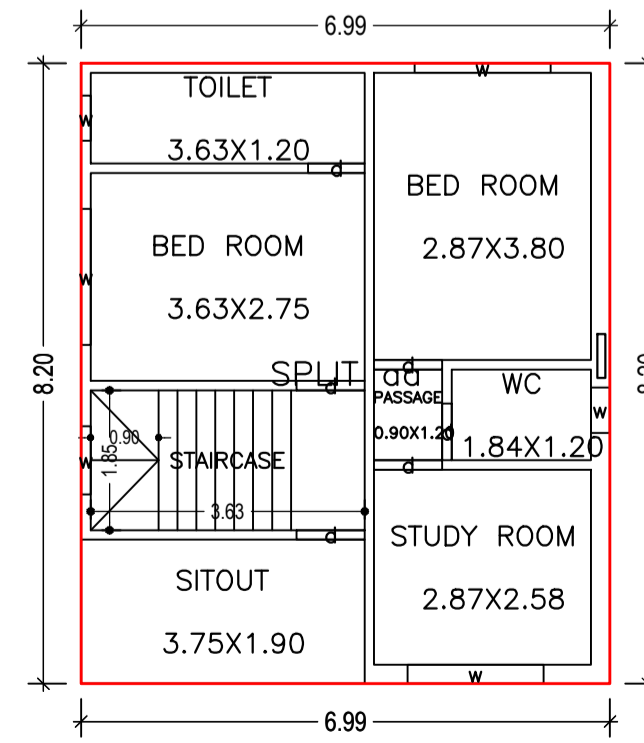

FIRST FLOOR PLAN  
(Proposed)  
(SCALE 1:100)

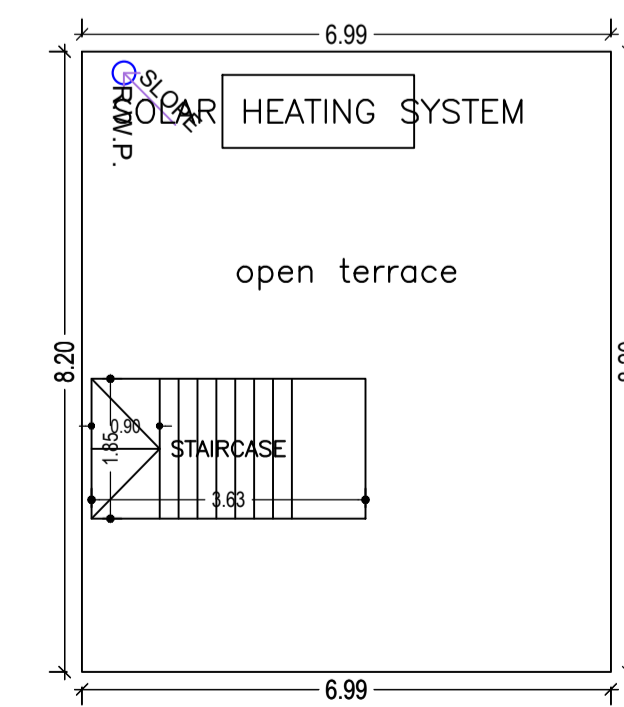

TERRACE FLOOR PLAN  
(SCALE 1:100)