

SITE PLAN

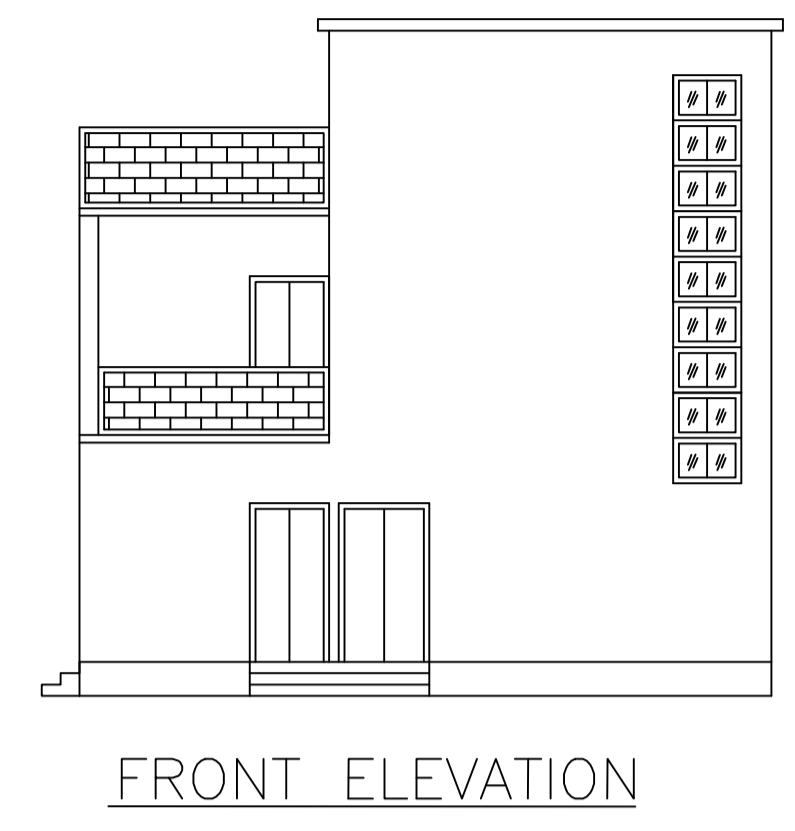

FRONT ELEVATION

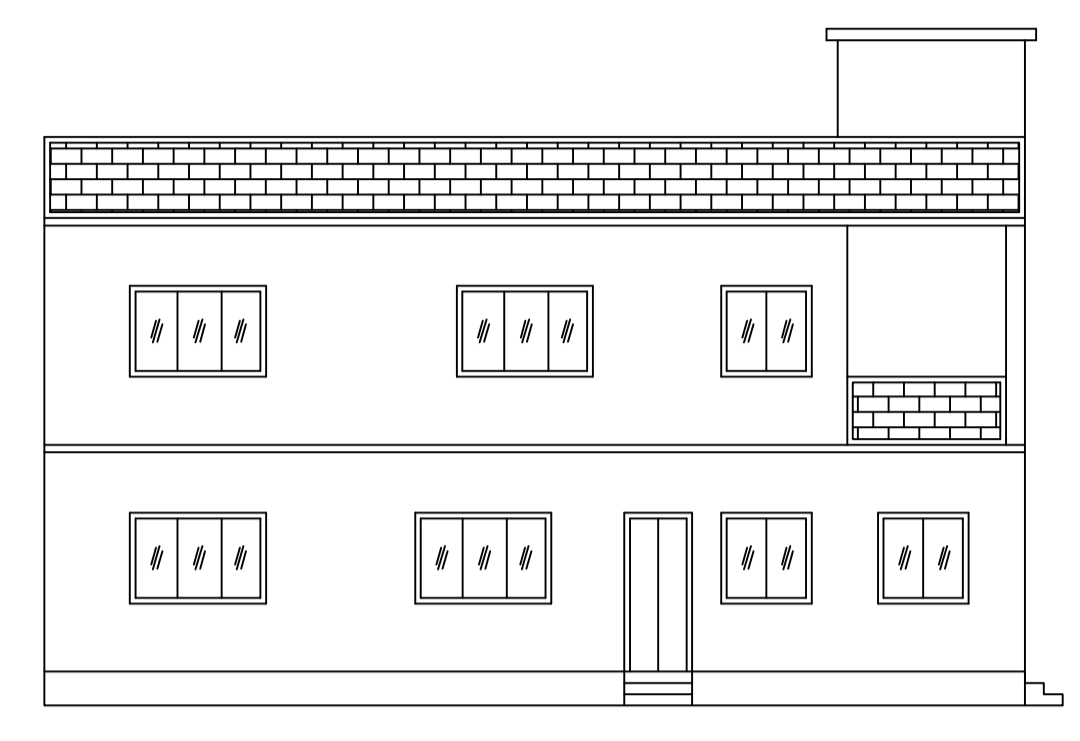

LEFT SIDE ELEVATION

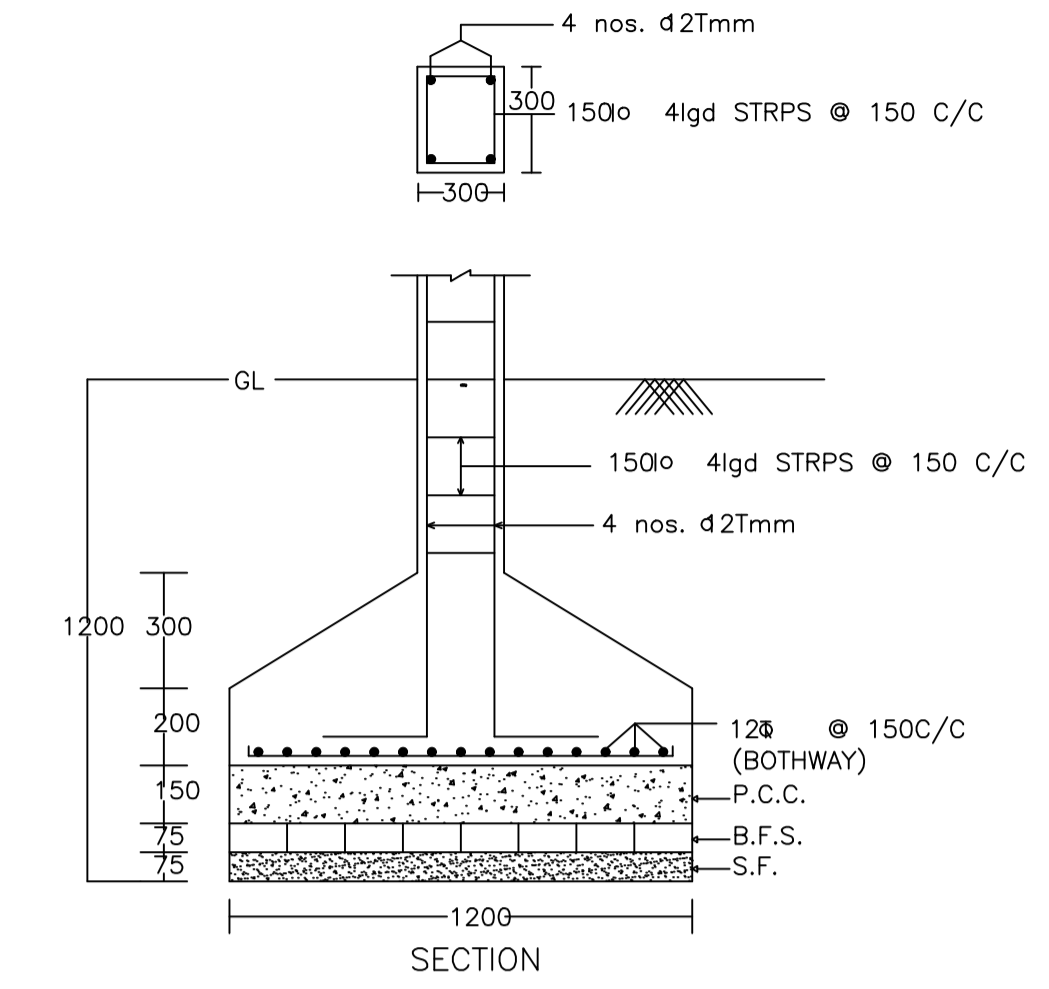

SECTION

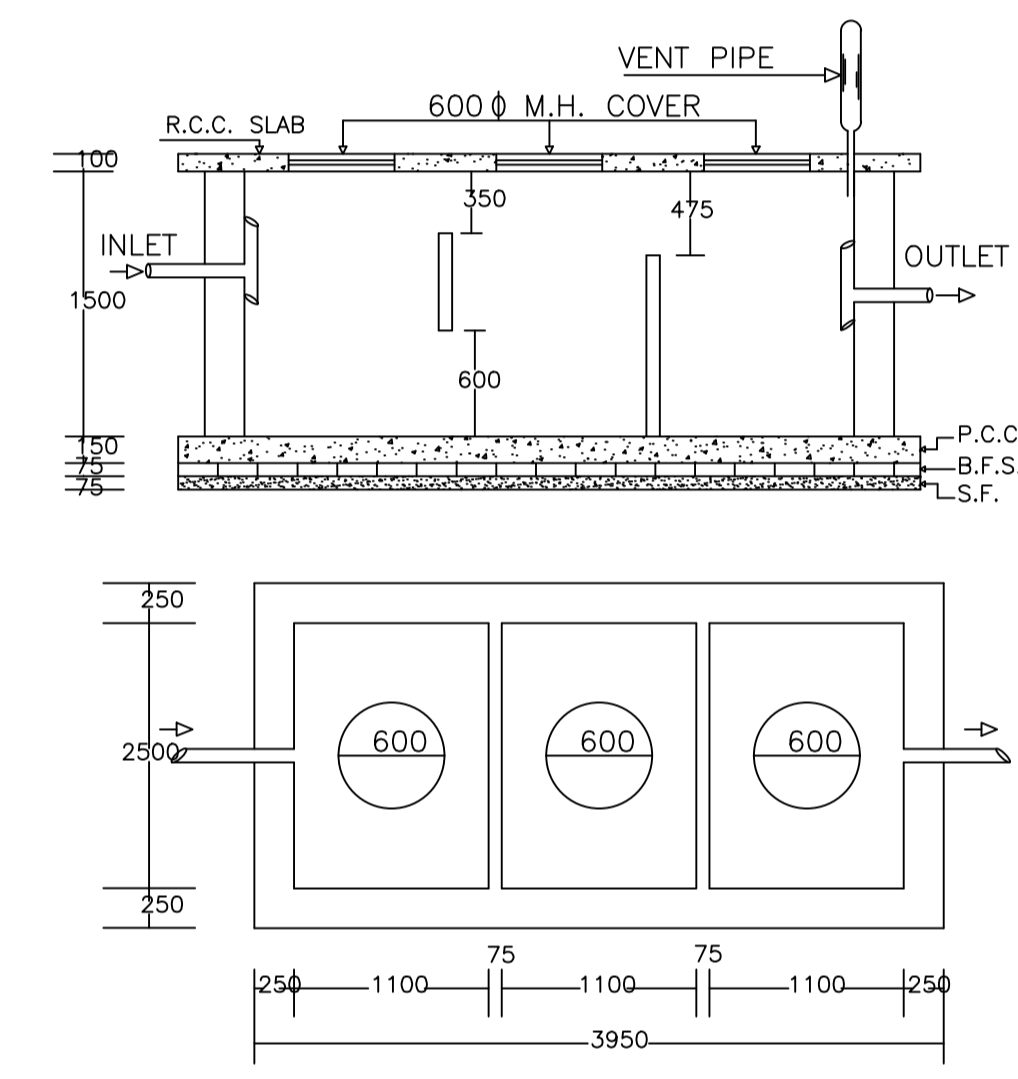

PLAN OF SEPTIC TANK

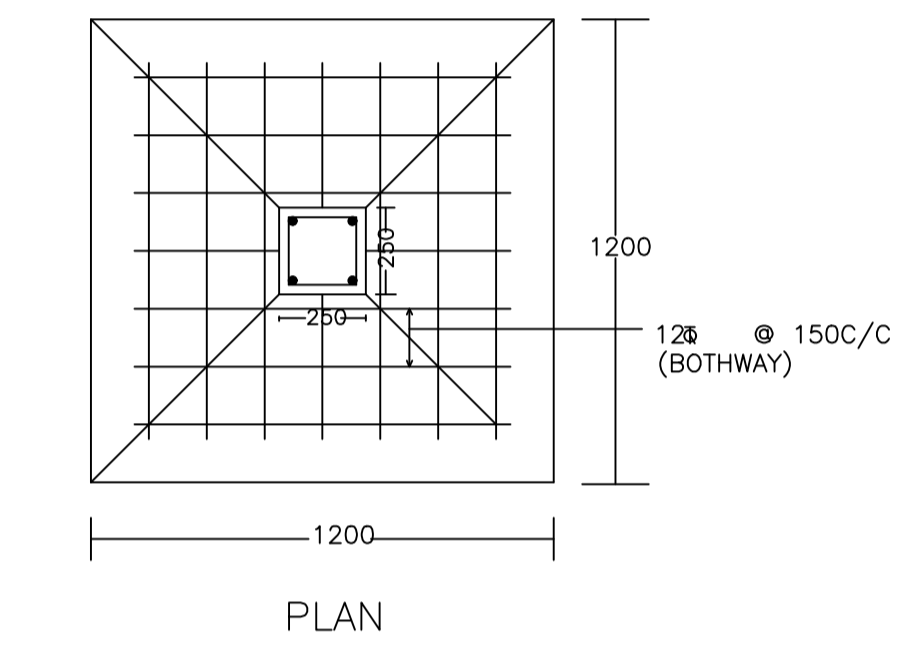

DETAIL OF COLUMNS

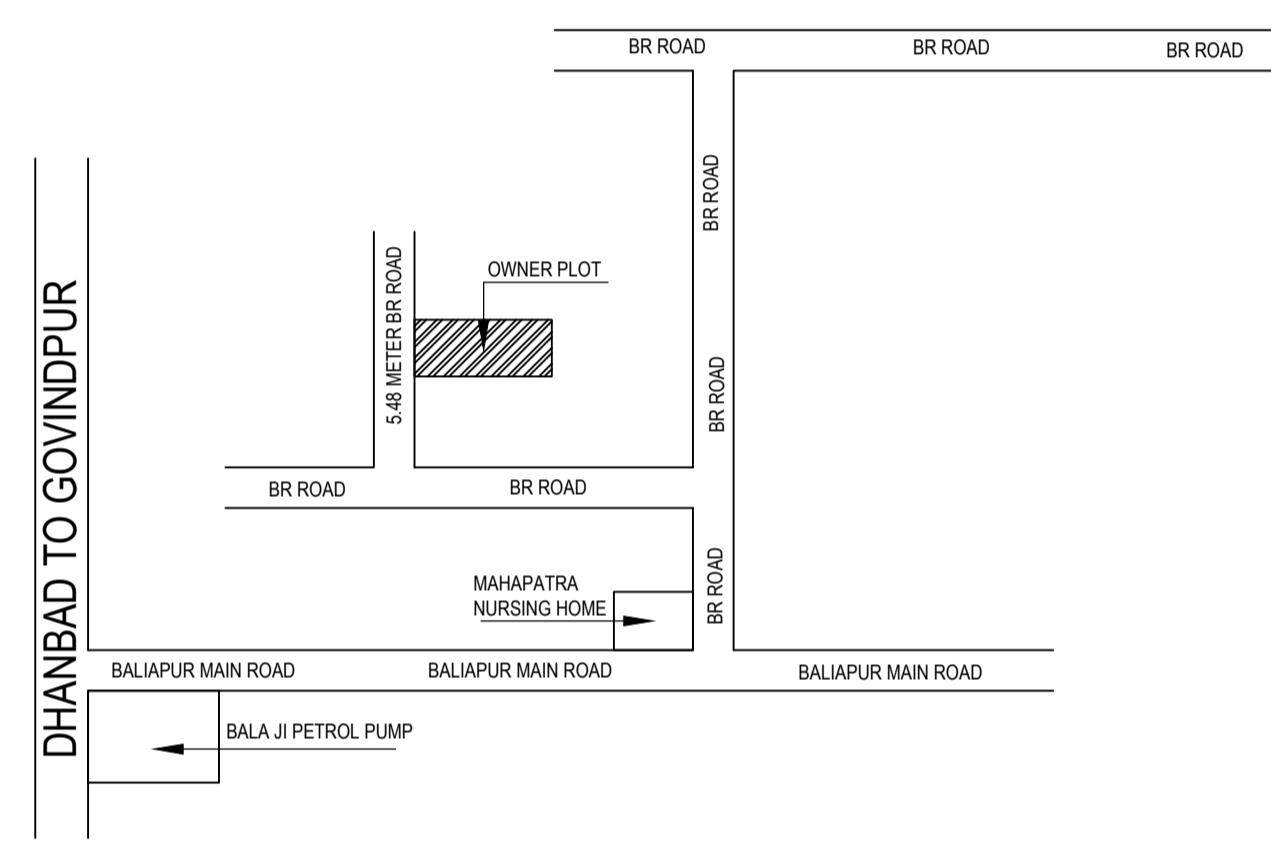

DHANBAD TO GOVINDPUR

Building :AA (AA)

Floor Name	Total Built Up Area (Sq. mt.)	Proposed FAR Area (Sq. mt.)	Total FAR Area (Sq. mt.)	Total Consumed Additional FAR Area (Sq. mt.)	Tnmt (No.)
Ground Floor	118.71	118.71	118.71	118.71	01
First Floor	118.71	118.71	118.71	118.71	00
Terrace Floor	0.00	0.00	0.00	0.00	00
Total :	237.42	237.42	237.42	237.42	01
Total Number of Same Buildings	1				
Total :	237.42	237.42	237.42	237.42	01

SCHEDULE OF DOOR:

BUILDING NAME	NAME	LENGTH	HEIGHT	NOS
AA (AA)	D	0.90	2.10	08
AA (AA)	D	1.05	2.10	09
AA (AA)	D	1.20	2.10	02

SCHEDULE OF WINDOW/VENTILATION:

BUILDING NAME	NAME	LENGTH	HEIGHT	NOS
AA (AA)	W	0.60	1.20	04
AA (AA)	W	0.90	1.20	02
AA (AA)	W	1.20	1.20	03
AA (AA)	W	1.80	1.20	12
AA (AA)	W	2.40	1.20	02

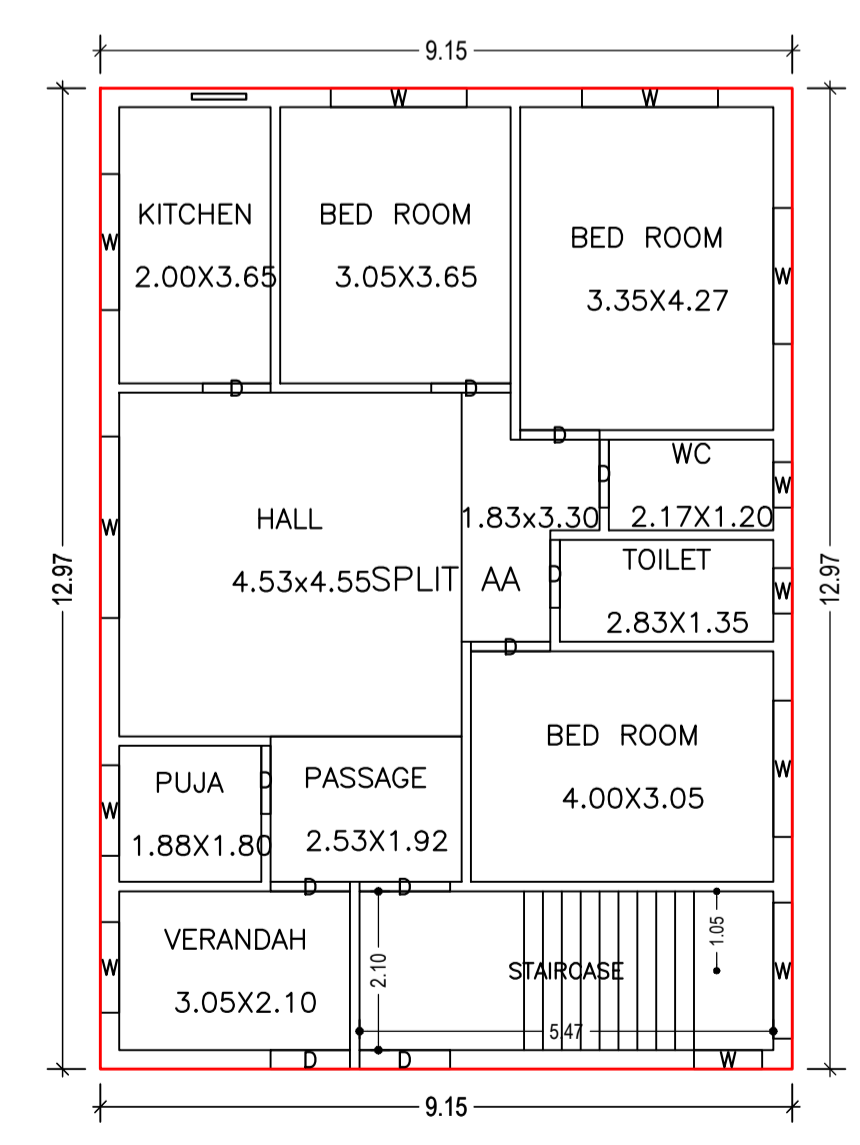

GROUND FLOOR PLAN (Proposed) (SCALE 1:100)

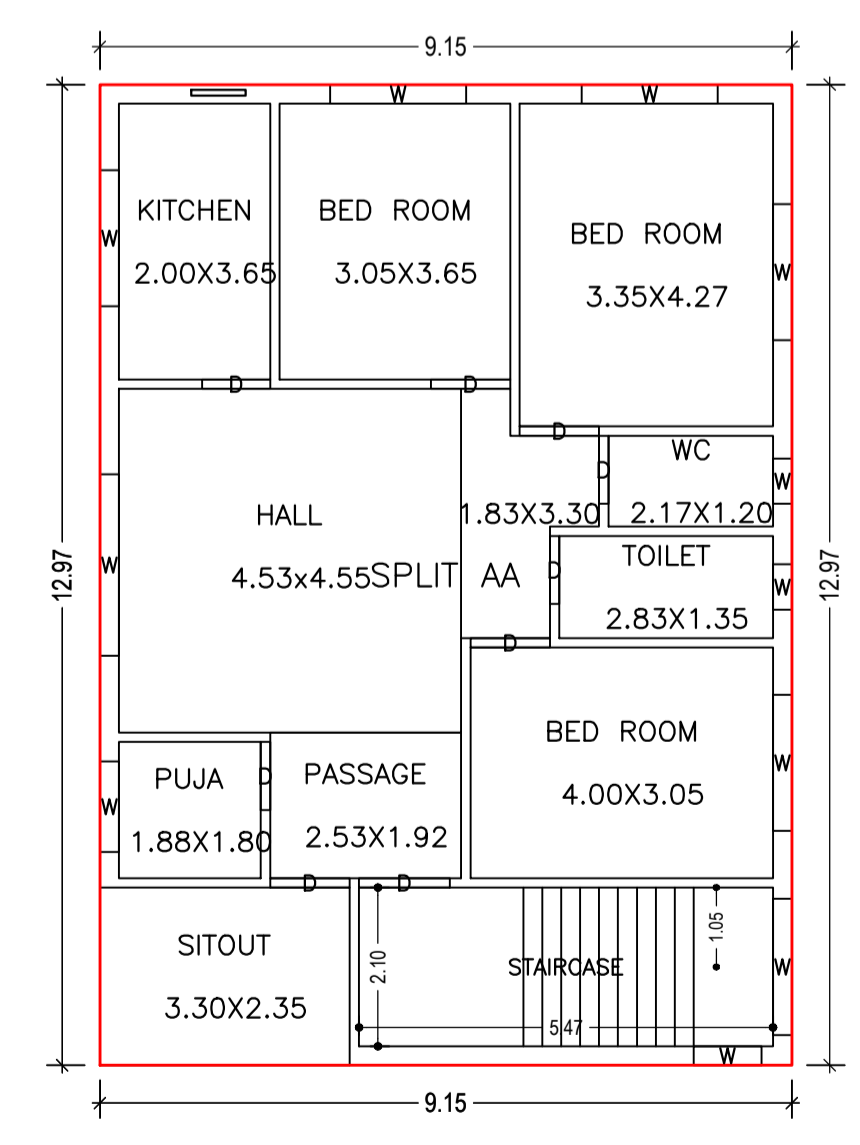

FIRST FLOOR PLAN (Proposed) (SCALE 1:100)

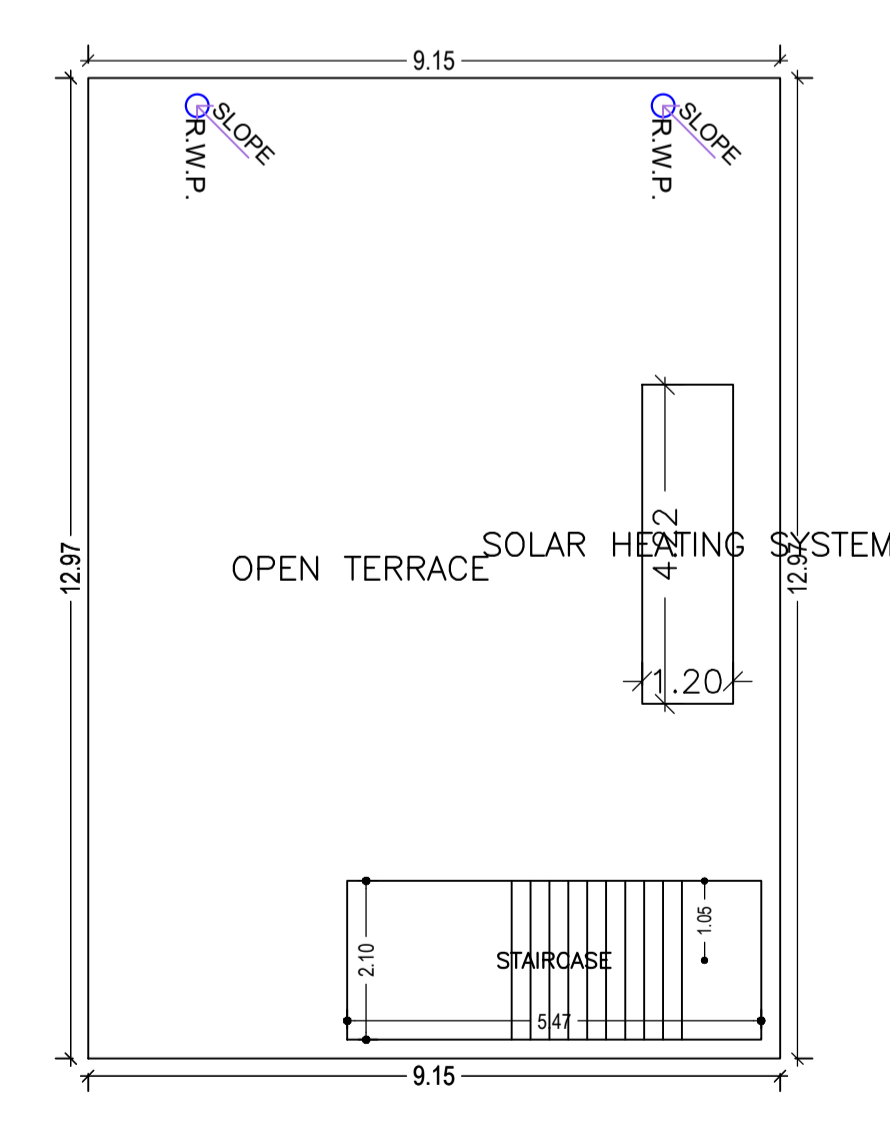

TERRACE FLOOR PLAN (SCALE 1:100)

Proposal Basic Information

Proposal File No.	DMC/BP/0210/W23/2021
Owner Name	SMT. BABITA SHARMA.
Khata No	84 (Old), 580 (New)
Plot No	1557 (Old), 1460 (New)
Village Name	Kolakusma
Use	Residential
SubUse	Bungalow/ Dwelling / Non Apartment

AREA STATEMENT

AREA OF PLOT (Minimum)	(A)	SQ.MT.
NET AREA OF PLOT(Gross Plot Area - Deduction from Gross Plot area)	(A-Deductions)	197.33
Deduction for Balance Plot Area(from Gross Plot Area)		
Common Plot		26.47
Total		26.47
BALANCE AREA OF PLOT(Net Plot Area - Recreational/Amenity Area)	(A-Deductions)	170.85
PLOT AREA FOR COVERAGE(Net Plot Area)	(A-Deductions)	197.33
Plot Area for FAR (Net Plot Area + RoadWidening Area)	(A-Deductions)	197.33
COVERAGE CHECK		
Permissible Coverage area (70.00 %)		138.13
Proposed Coverage Area (60.16 %)		118.71
Total Prop. Coverage Area (60.16 %)		118.71
Balance coverage area (9.84 %)		19.42
FAR CHECK		
Perm. FAR Area (1.80)		355.19
Total Perm. FAR area		355.19
Residential FAR		237.42
Proposed FAR Area		237.42
Total Proposed FAR Area		237.42
Consumed FAR (Factor)		1.20
Balance FAR Area		117.77
BUILT UP AREA CHECK		
Total Proposed BuiltUp Area		237.42
ARCHITECT (Regd)	PARTHA - PAL	
ENGINEER (Regd)		
SUPERVISOR (Regd)		
OWNER (Regd)	SMT. BABITA SHARMA.	
DEVELOPMENT AUTHORITY	LOCAL BODY	

COLOR INDEX

PLOT BOUNDARY	Black
ABUTTING ROAD	Green
PROPOSED CONSTRUCTION	Red
COMMON PLOT	Yellow
ROAD WIDENING AREA	Orange
EXISTING (To be retained)	Blue
EXISTING (To be demolished)	Light Blue

Buildingwise Floor FAR Details

Floor Name	Building Name		Total	
	Proposed Built Up Area (Sq. mt.)	Proposed FAR Area (Sq. mt.)	Total Proposed Built Up Area (Sq. mt.)	Total FAR Area (Sq. mt.)
Ground Floor	118.71	118.71	118.71	118.71
First Floor	118.71	118.71	118.71	118.71
Terrace Floor	0.00	0.00	0.00	0.00
Total :	237.42	237.42	237.42	237.42

Building USE/SUBUSE Details

Building Name	Building Use	Building SubUse	Building Structure
AA (AA)	Residential	Bungalow/ Dwelling / Non Apartment	Non-Highrise

FAR & Tenement Details (Table 4c-1)

Building	No. of Same Bldg	Total Built Up Area (Sq. mt.)	Proposed FAR Area (Sq. mt.)	Total FAR Area (Sq. mt.)	Total Consumed Additional FAR Area (Sq. mt.)	Tnmt (No.)
AA (AA)	1	237.42	237.42	237.42	237.42	01
Grand Total :	1	237.42	237.42	237.42	237.42	01

UnitBUA Table for Building :AA (AA)

FLOOR	Name	UnitBUA Type	UnitBUA Area	Carpet Area	No. of Rooms	No. of Tenement
GROUND FLOOR PLAN	SPLIT AA	FLAT	237.42	237.32	10	1
FIRST FLOOR PLAN	SPLIT AA	FLAT	0.00	0.00	10	0
Total:	-	-	237.42	237.32	20	1

LTP NAME AND SIGNATURE	STRUCTURAL ENG'S NAME AND SIGNATURE	BUILDER NAME AND SIGNATURE	DIGITAL SIGNATURE
PARTHA - PAL DMC/ENG/0021/2016			

Proposal Basic Information	
Proposal File No.	DMC/BP/0210/W23/2021
Owner Name	SMT. BABITA SHARMA.
Khata No	84 (Old), 580 (New)
Plot No	1557 (Old), 1460 (New)
Village Name	Kolakusma
Use	Residential
SubUse	Bungalow/ Dwelling / Non Apartment

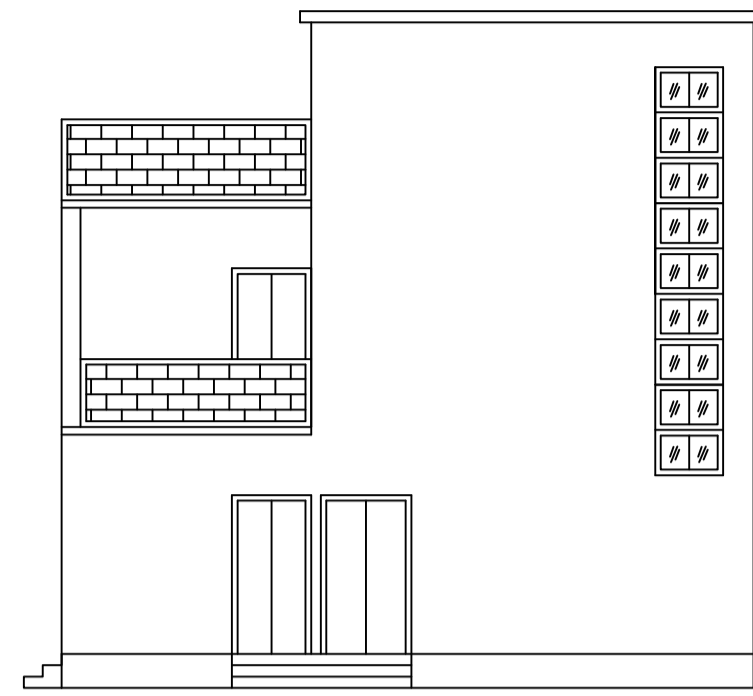

FRONT ELEVATION

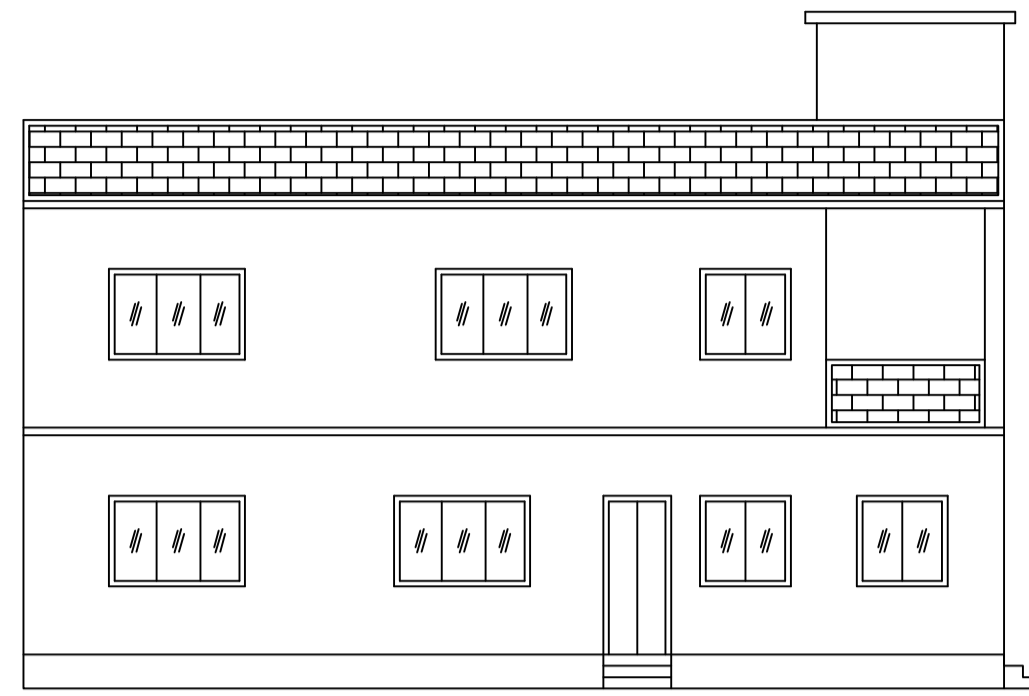

LEFT SIDE ELEVATION

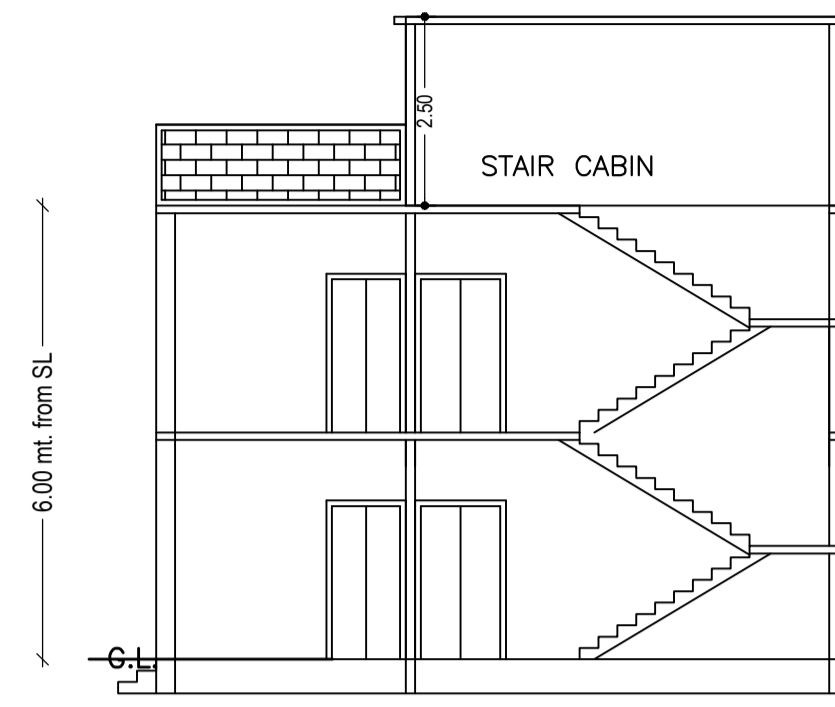

SECTION ON X-X

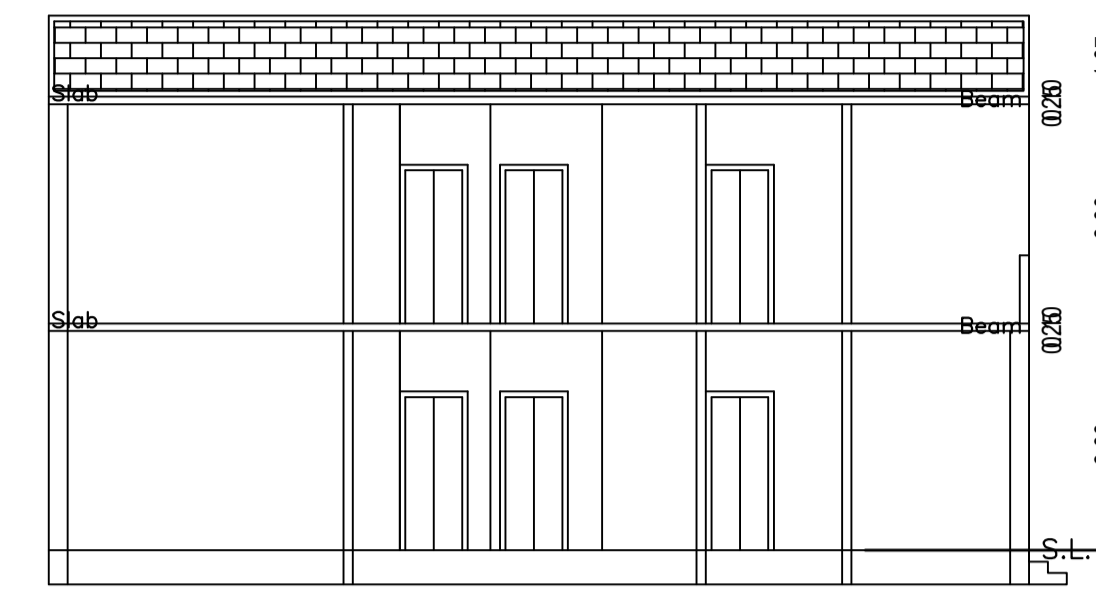

SECTION ON Y-Y

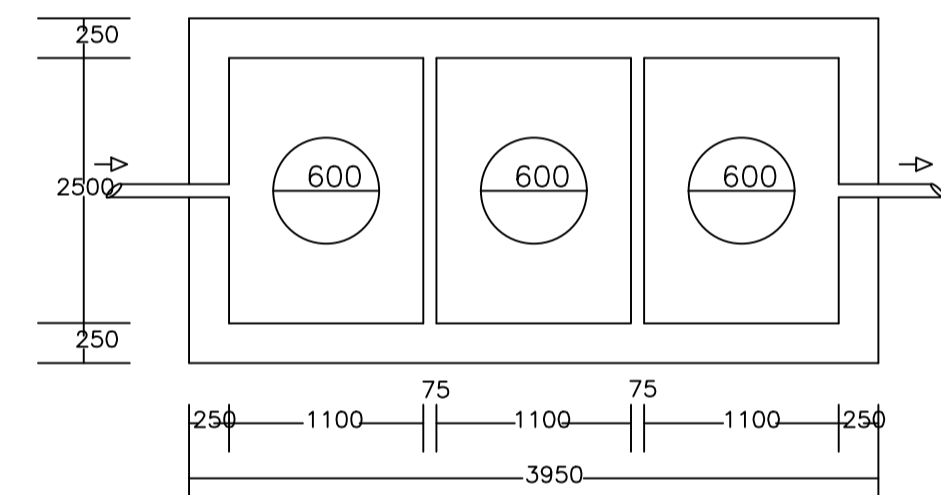
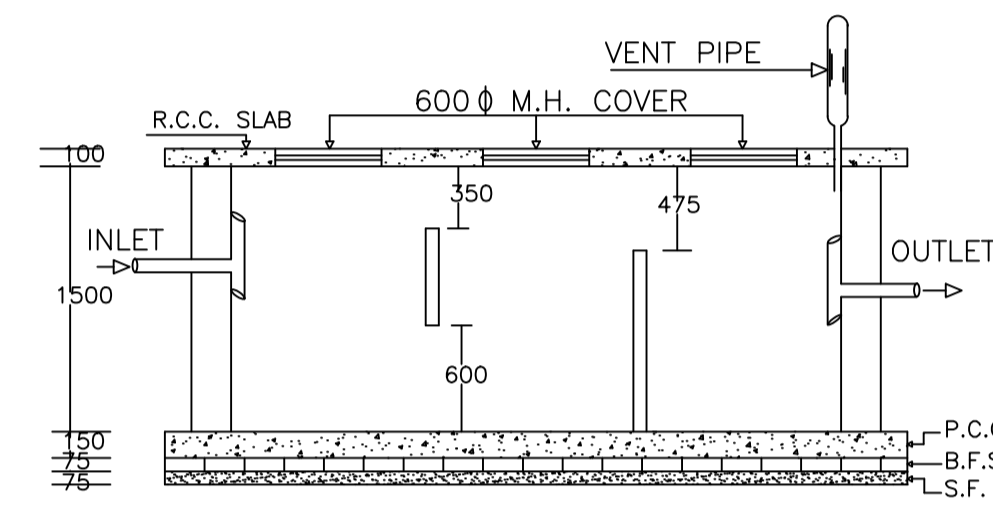
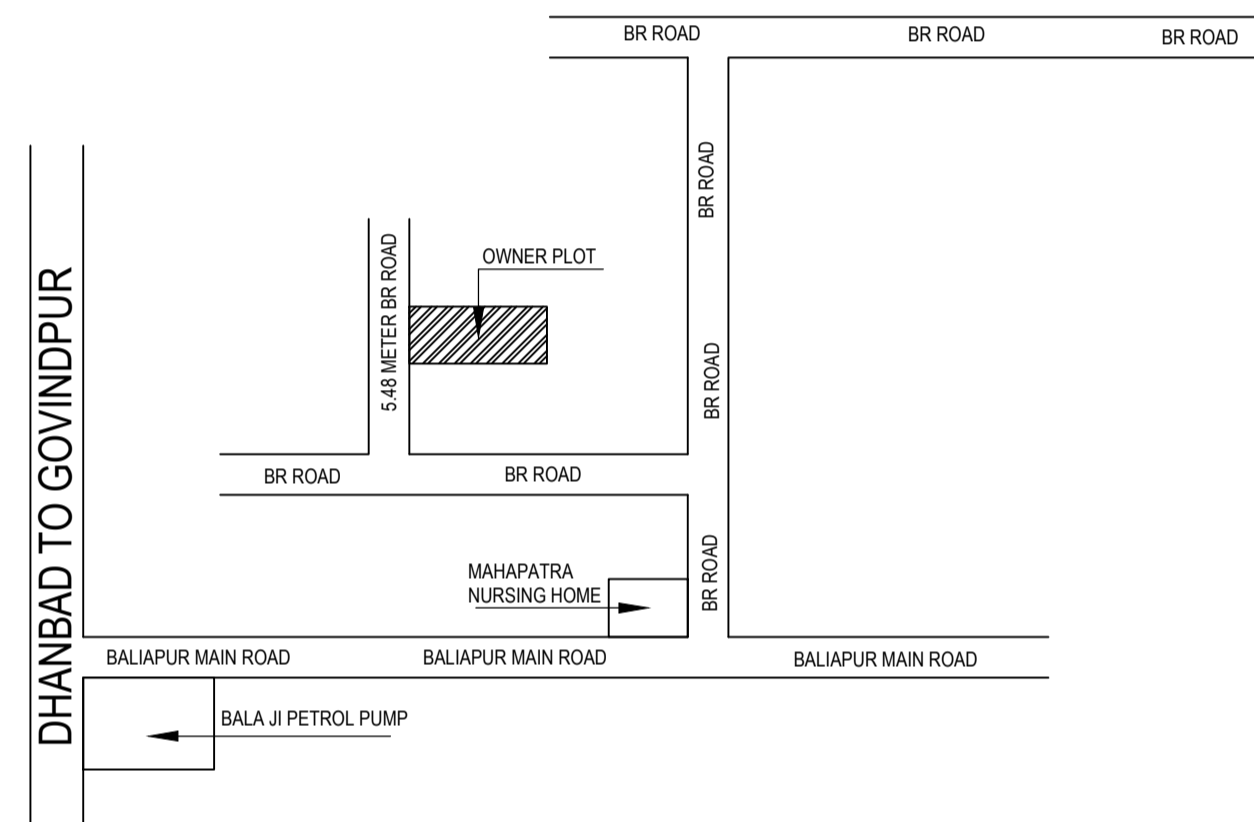

PLAN OF SEPTIC TANK

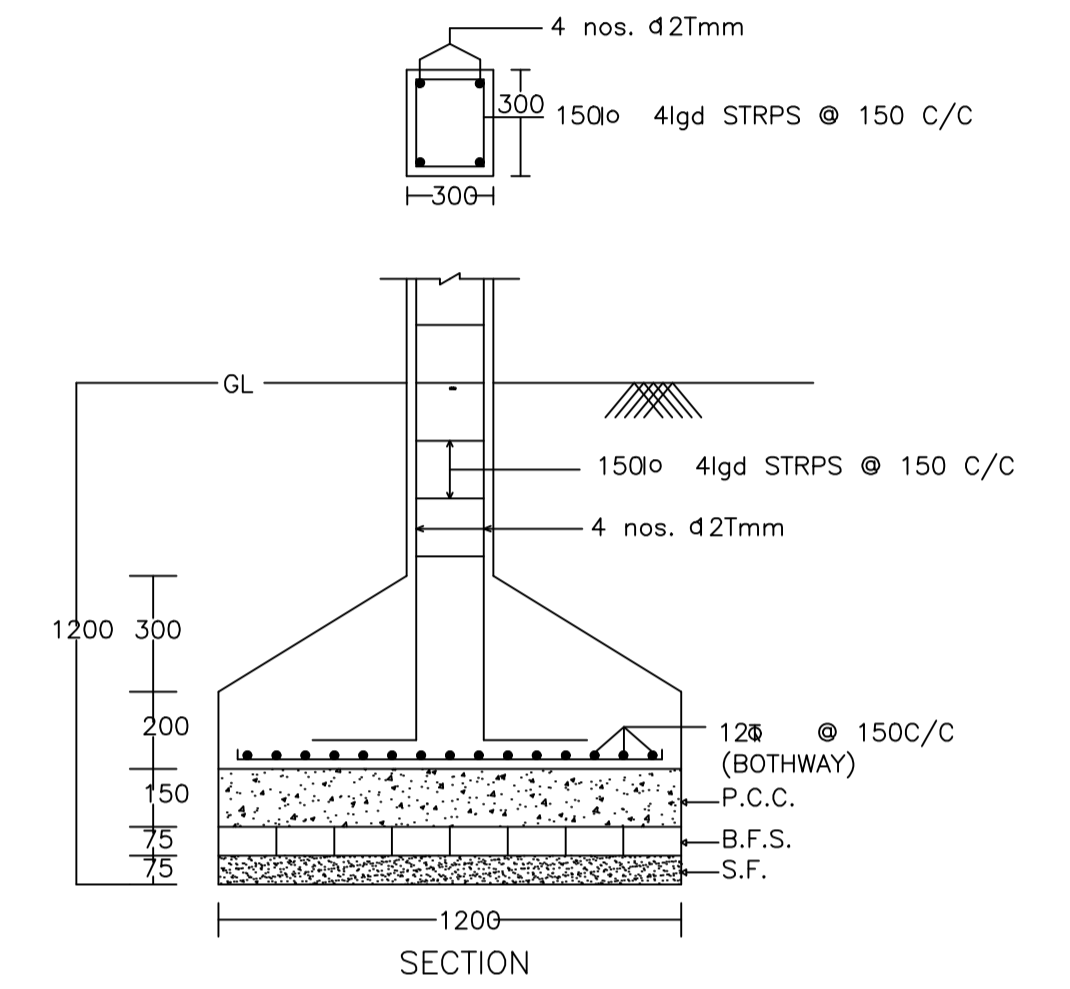
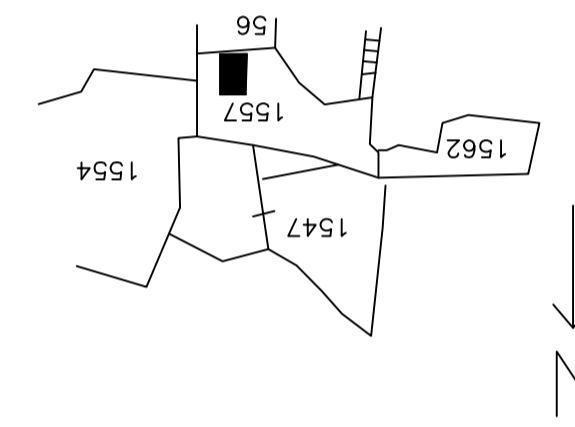

SECTION

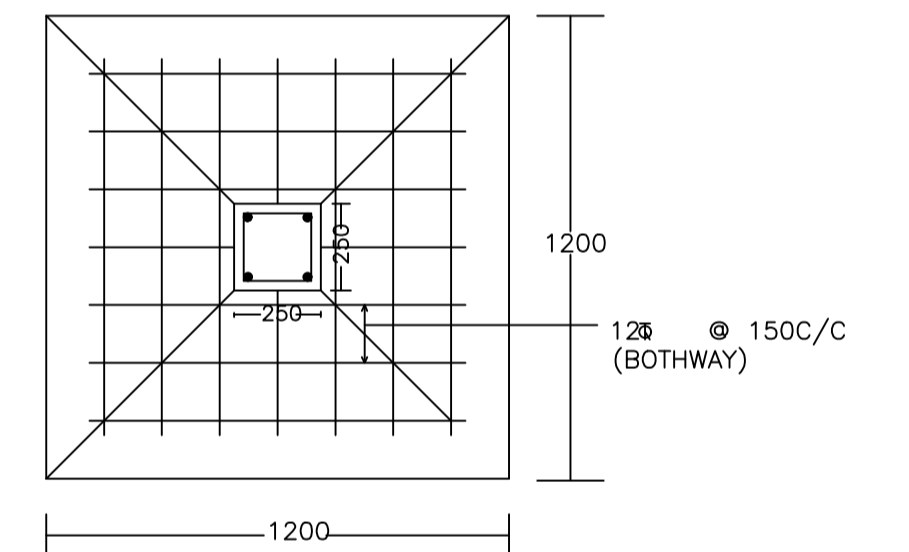

PLAN

DETAIL OF COLUMNS

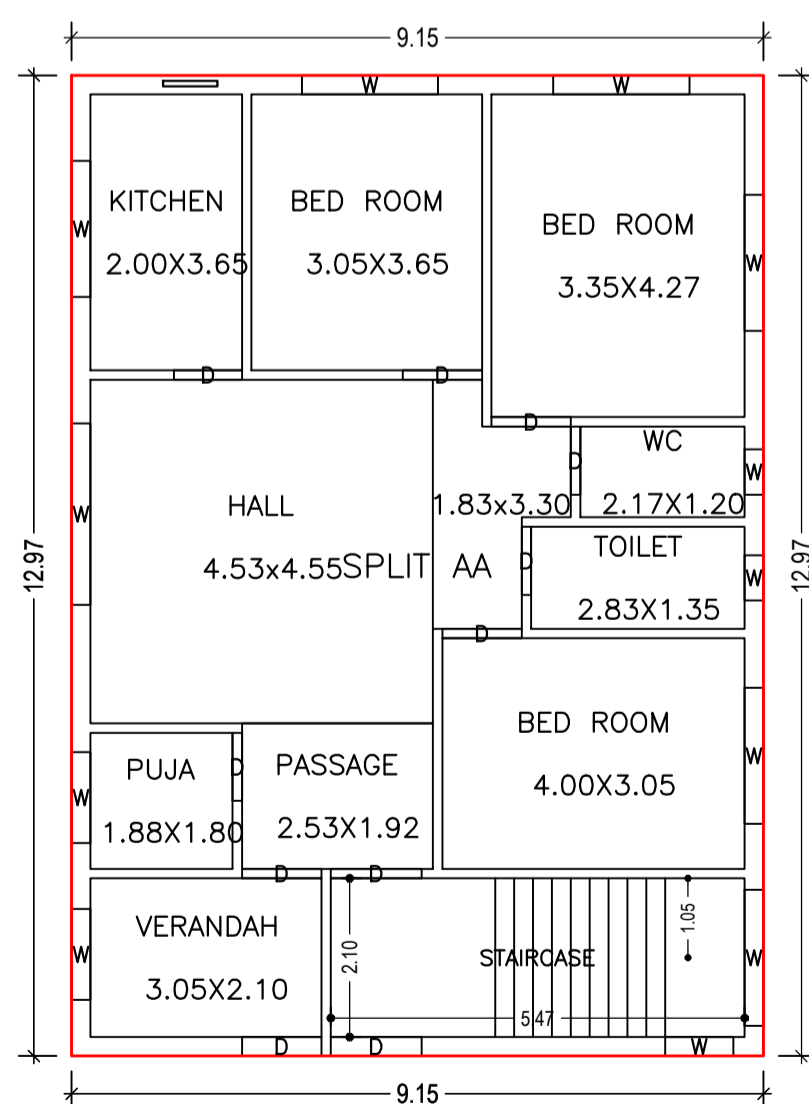

GROUND FLOOR PLAN
(Proposed)
(SCALE 1:100)

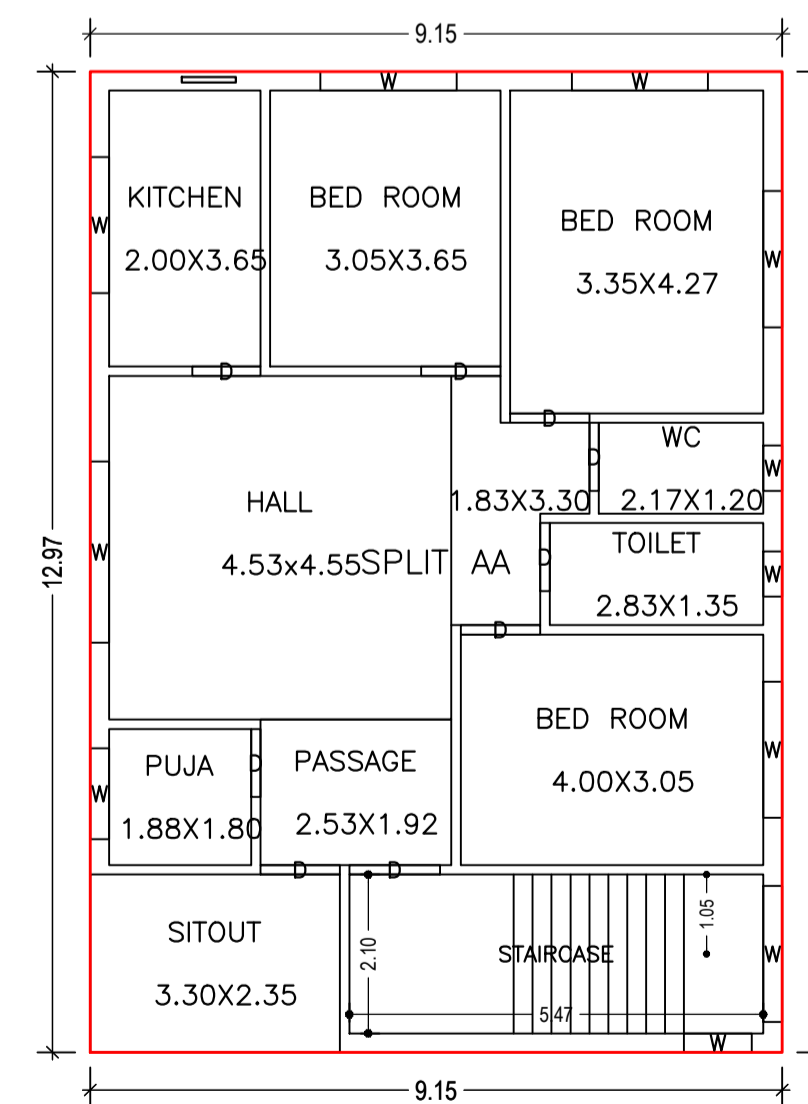

FIRST FLOOR PLAN
(Proposed)
(SCALE 1:100)

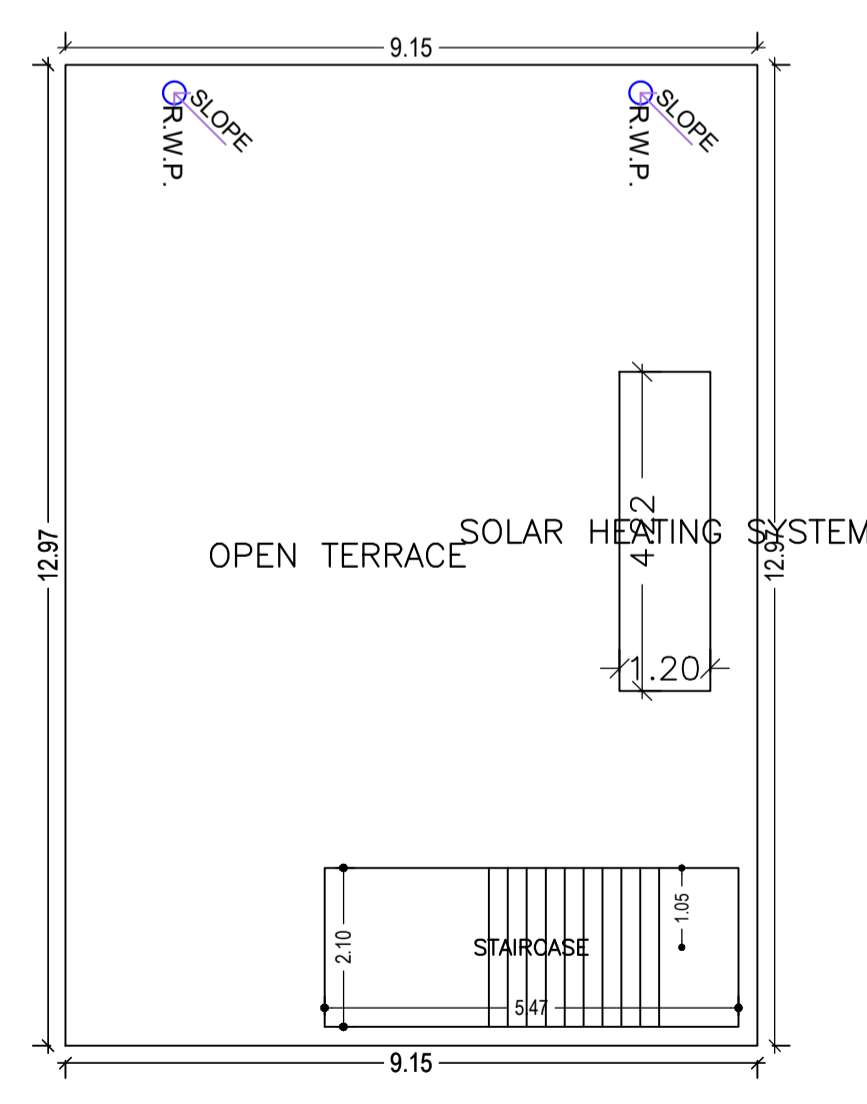

TERRACE FLOOR PLAN
(SCALE 1:100)

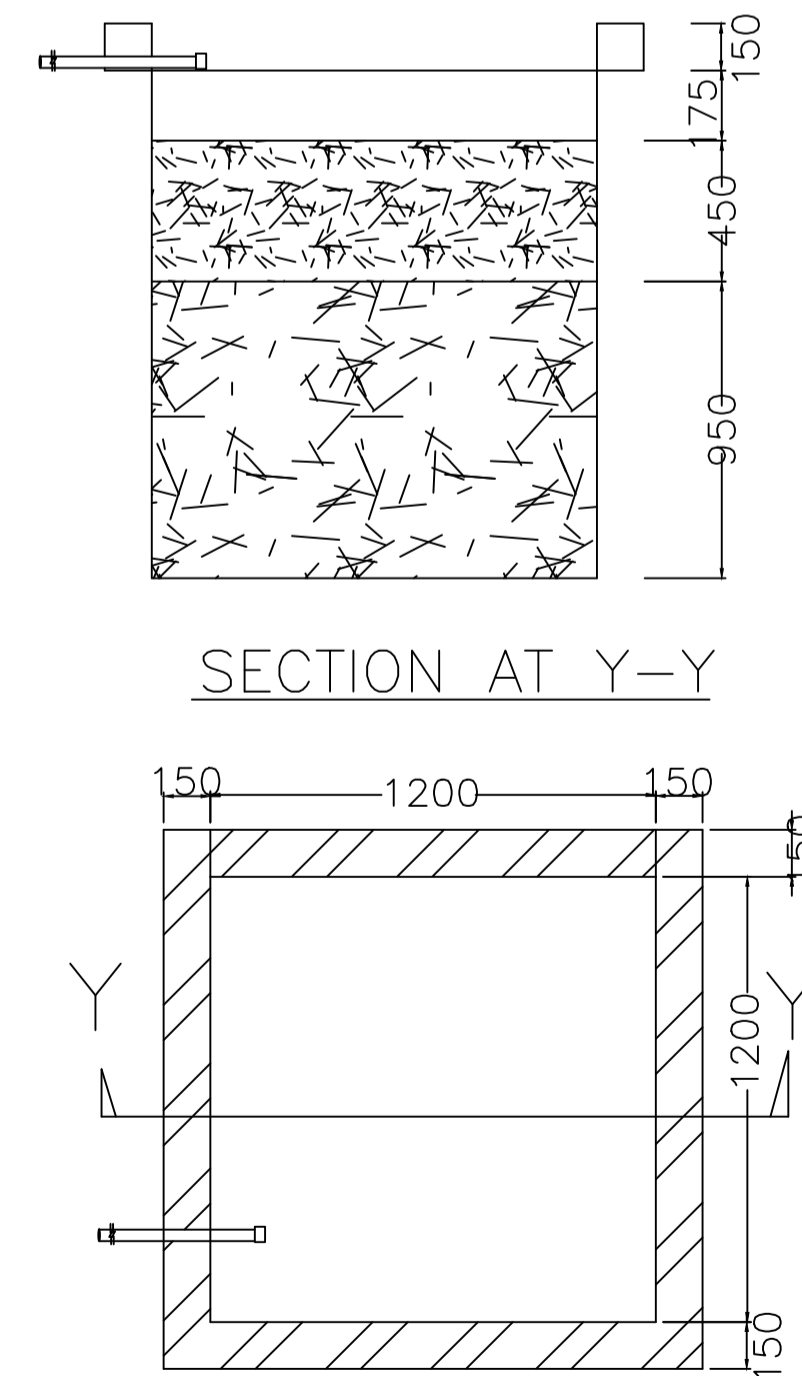

PLAN OF RECHARGE WELL
WATER HARVESTING

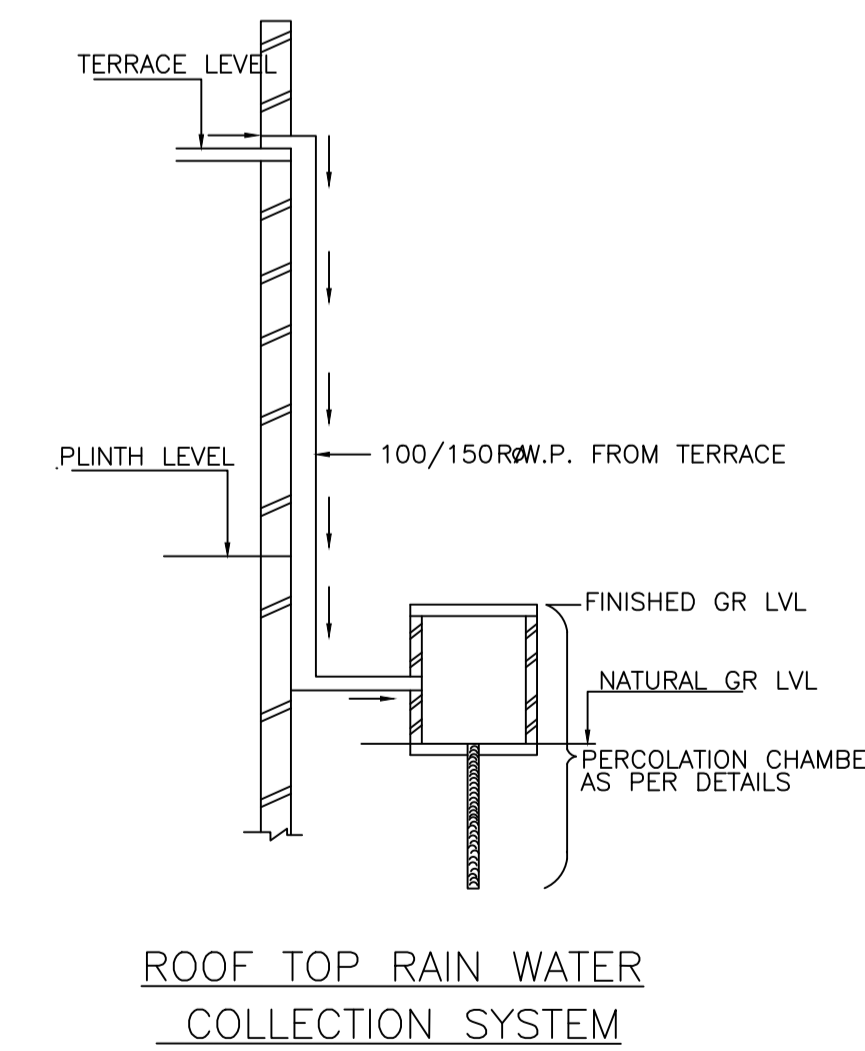

ROOF TOP RAIN WATER
COLLECTION SYSTEM

LTP NAME AND SIGNATURE	STRUCTURAL ENG'S NAME AND SIGNATURE	BUILDER NAME AND SIGNATURE	DIGITAL SIGNATURE
PARTHA - PAL DMC/ENG/0021/2016			