

Building USE/SUBUSE Details

Building Name	Building Use	Building SubUse	Building Structure
A (SMT MANORAMA DEVI)	Residential	Residential Bldg/Apartment	Non-Highrise

Building :A (SMT MANORAMA DEVI)

Floor Name	Total Built Up Area (Sq.mt.)	Deductions (Area in Sq.mt.)	Proposed FAR Area (Sq.mt.)	Total FAR Area (Sq.mt.)	Total Consumed Additional FAR Area (Sq.mt.)	Tnmt (No.)
Ground Floor	107.96	9.31	98.65	98.65	98.65	01
First Floor	107.95	0.00	107.95	107.95	107.95	00
Terrace Floor	0.00	0.00	0.00	0.00	0.00	00
Total :	215.91	9.31	206.60	206.60	206.60	01
Total Number of Same Buildings	1					
Total :	215.91	9.31	206.60	206.60	206.60	01

SCHEDULE OF DOOR:

BUILDING NAME	NAME	LENGTH	HEIGHT	NOS
A (SMT MANORAMA DEVI)	D	0.76	2.10	06
A (SMT MANORAMA DEVI)	D	0.91	2.10	02
A (SMT MANORAMA DEVI)	D	1.03	2.10	02
A (SMT MANORAMA DEVI)	D	1.07	2.10	04
A (SMT MANORAMA DEVI)	D	1.14	2.10	01
A (SMT MANORAMA DEVI)	D	1.22	2.10	02

SCHEDULE OF WINDOW/VENTILATION:

BUILDING NAME	NAME	LENGTH	HEIGHT	NOS
A (SMT MANORAMA DEVI)	W	0.69	1.20	02
A (SMT MANORAMA DEVI)	W	0.78	1.20	02
A (SMT MANORAMA DEVI)	W	1.08	1.20	02
A (SMT MANORAMA DEVI)	W	1.30	1.20	02
A (SMT MANORAMA DEVI)	W	1.73	1.20	02
A (SMT MANORAMA DEVI)	W	1.83	1.20	02
A (SMT MANORAMA DEVI)	W	1.86	1.20	02
A (SMT MANORAMA DEVI)	W	2.18	1.20	02
A (SMT MANORAMA DEVI)	W	2.26	1.20	02
A (SMT MANORAMA DEVI)	W	2.39	1.20	02
A (SMT MANORAMA DEVI)	W	2.66	1.20	02
A (SMT MANORAMA DEVI)	W	2.78	1.20	02

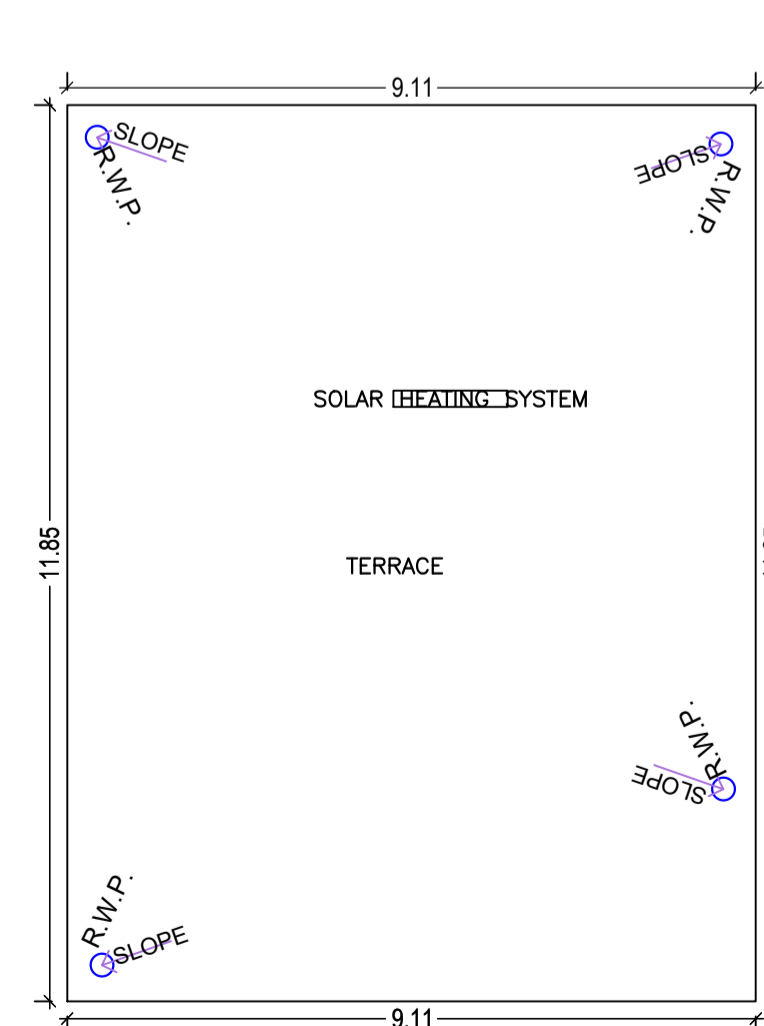
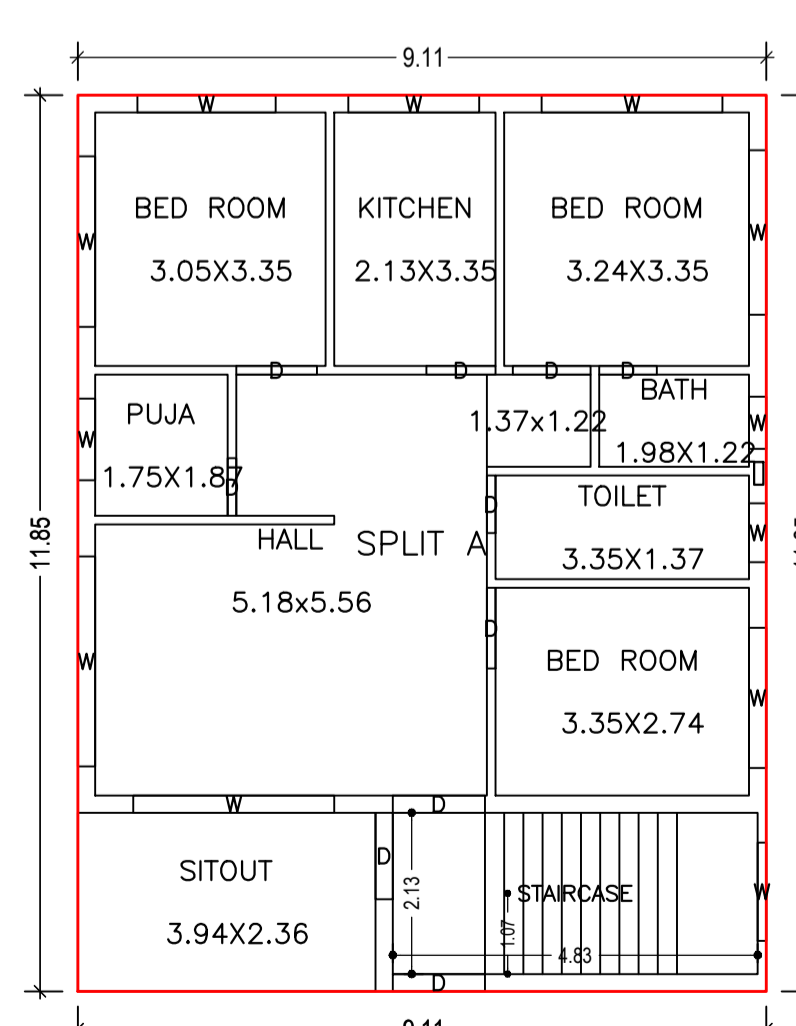
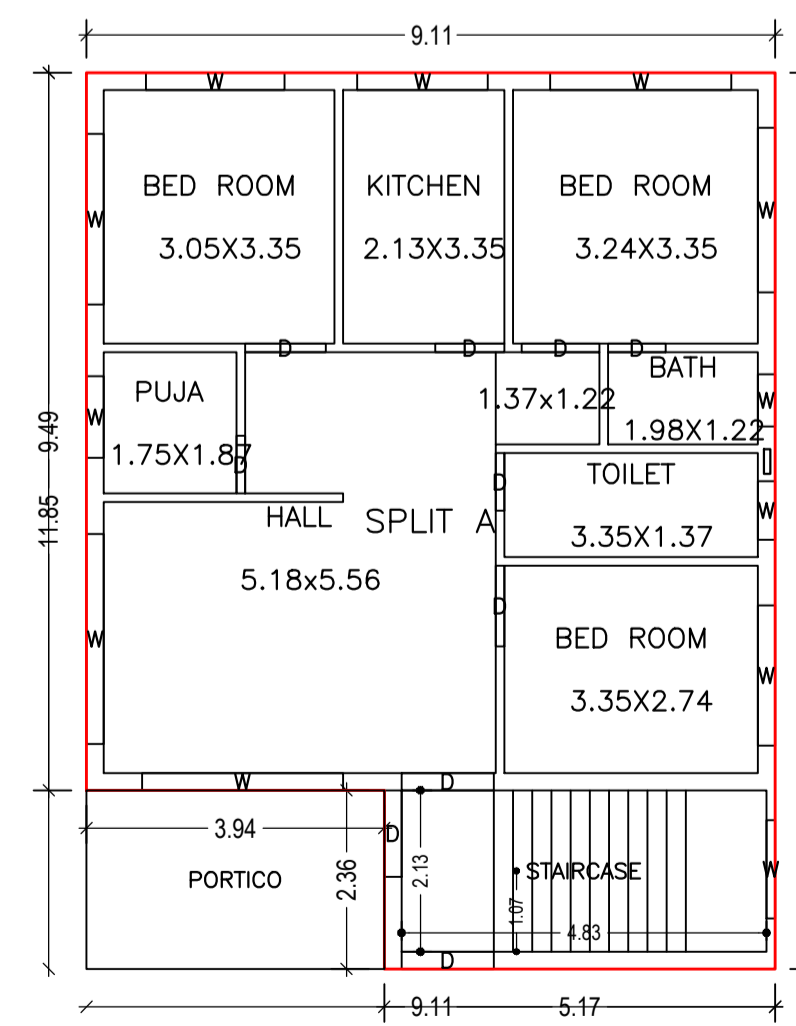

Proposal Basic Information

Proposal File No.	DMC/BP/0236/W15/2021
Owner Name	SMT MANORAMA DEVI
Khata No	81,NEW-655
Plot No	2445,NEW-1948
Village Name	Bhuli
Use	Residential
SubUse	Bungalow/ Dwelling / Non Apartment

AREA STATEMENT

VERSION NO. : 1.0.61
VERSION DATE: 16/10/2020

PROJECT DETAIL:

Region: JHARKHAND URBAN LOCAL BODIES	Plot Use: Residential
District: DHANBAD CORPORATION	Plot SubUse: Bungalow/ Dwelling / Non Apartment
Authority: DHANBAD MUNICIPAL CORPORATION	PlotNearby/ReligiousStructure: NA
Inward No: DMC/BP/0236/W15/2021	Plot/SubPlot No: 2445,NEW-1948
Application Type: General Proposal	North: Road Width - 4.57
Project Type: Building Permission	South: Plot No. - MUKESH KUMAR SINGH
Nature of Development: New	East: Plot No. - 2439
Location of Development Area: Old Area	West: Road Width - 3.7

AREA DETAILS:

AREA OF PLOT (Minimum)	(A)	SQ.MT.
NET AREA OF PLOT(Gross Plot Area - Deduction from Gross Plot area)	(A-Deductions)	179.35
Deduction for Balance Plot Area(from Gross Plot Area)		
Common Plot		41.81
Total		41.81
BALANCE AREA OF PLOT(Net Plot Area - Recreational/Amenity space)	(A-Deductions)	137.54
PLOT AREA FOR COVERAGE(Net Plot Area)	(A-Deductions)	179.35
Plot Area for FAR (Net Plot Area + Road Widening Area)	(A-Deductions)	179.35

COVERAGE CHECK

Permissible Coverage area (70.00 %)	125.55
Proposed Coverage Area (55.00 %)	98.65
Total Prop. Coverage Area (55 %)	98.65
Balance coverage area (15.00 %)	26.90

FAR CHECK

Perm. FAR Area (1.50)	269.03
Total Perm. FAR area	269.03
Residential FAR	206.60
Proposed FAR Area	206.60
Total Proposed FAR Area	206.60
Consumed FAR (Factor)	1.15
Balance FAR Area	62.43

BUILT UP AREA CHECK

Total Proposed BuiltUp Area	215.91
ARCHITECT (Regd)	RAJEEV RANJAN SINGH
ENGINEER (Regd)	
SUPERVISOR (Regd)	
OWNER (Regd)	SMT MANORAMA DEVI
DEVELOPMENT AUTHORITY	LOCAL BODY

COLOR INDEX

PLOT BOUNDARY	Black
ABUTTING ROAD	Green
PROPOSED CONSTRUCTION	Red
COMMON PLOT	Yellow
ROAD WIDENING AREA	Blue
EXISTING (To be retained)	Orange
EXISTING (To be demolished)	Light Blue

Buildingwise Floor FAR Details

Floor Name	Building Name		Total	
	Proposed Built Up Area (Sq.mt.)	Proposed FAR Area (Sq.mt.)	Total Proposed Built Up Area (Sq.mt.)	Total FAR Area (Sq.mt.)
Ground Floor	107.96	98.65	107.96	98.65
First Floor	107.95	107.95	107.95	107.95
Terrace Floor	0.00	0.00	0.00	0.00
Total :	215.91	206.60	215.91	206.60

FAR & Tenement Details (Table 4c-1)

Building	No. of Same Bldg	Total Built Up Area (Sq.mt.)	Deductions (Area in Sq.mt.)	Proposed FAR Area (Sq.mt.)	Total FAR Area (Sq.mt.)	Consumed Additional FAR Area (Sq.mt.)	Tnmt (No.)
A (SMT MANORAMA DEVI)	1	215.91	9.31	206.60	206.60	206.60	01
Grand Total :	1	215.91	9.31	206.60	206.60	206.60	01

UnitBUA Table for Building :A (SMT MANORAMA DEVI)

FLOOR	Name	UnitBUA Type	UnitBUA Area	Carpet Area	No. of Rooms	No. of Tenement
GROUND FLOOR PLAN	SPLIT A	FLAT	206.60	206.54	8	1
FIRST FLOOR PLAN	SPLIT A	FLAT	0.00	0.00	9	0
Total:	-	-	206.60	206.54	17	1

LTP NAME AND SIGNATURE	STRUCTURAL ENG'S NAME AND SIGNATURE	BUILDER NAME AND SIGNATURE	DIGITAL SIGNATURE
RAJEEV RANJAN SINGH DMC/ENG/0032/2017			

Proposal Basic Information	
Proposal File No.	DMC/BP/0236/W15/2021
Owner Name	SMT MANORAMA DEVI
Khata No	81,NEW-655
Plot No	2445,NEW-1948
Village Name	Bhuli
Use	Residential
SubUse	Bungalow/ Dwelling / Non Apartment

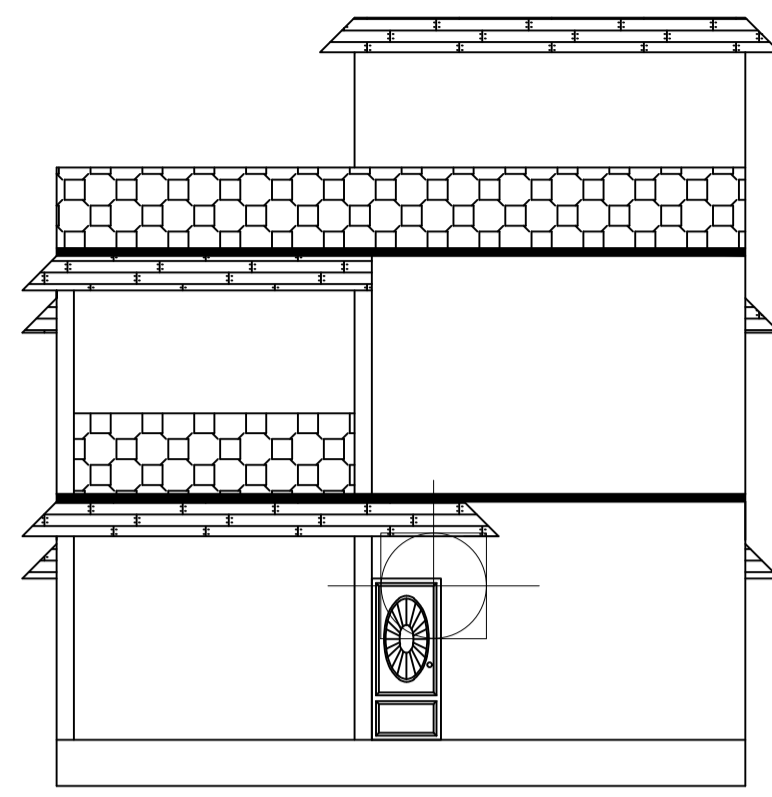

FRONT ELEVATION

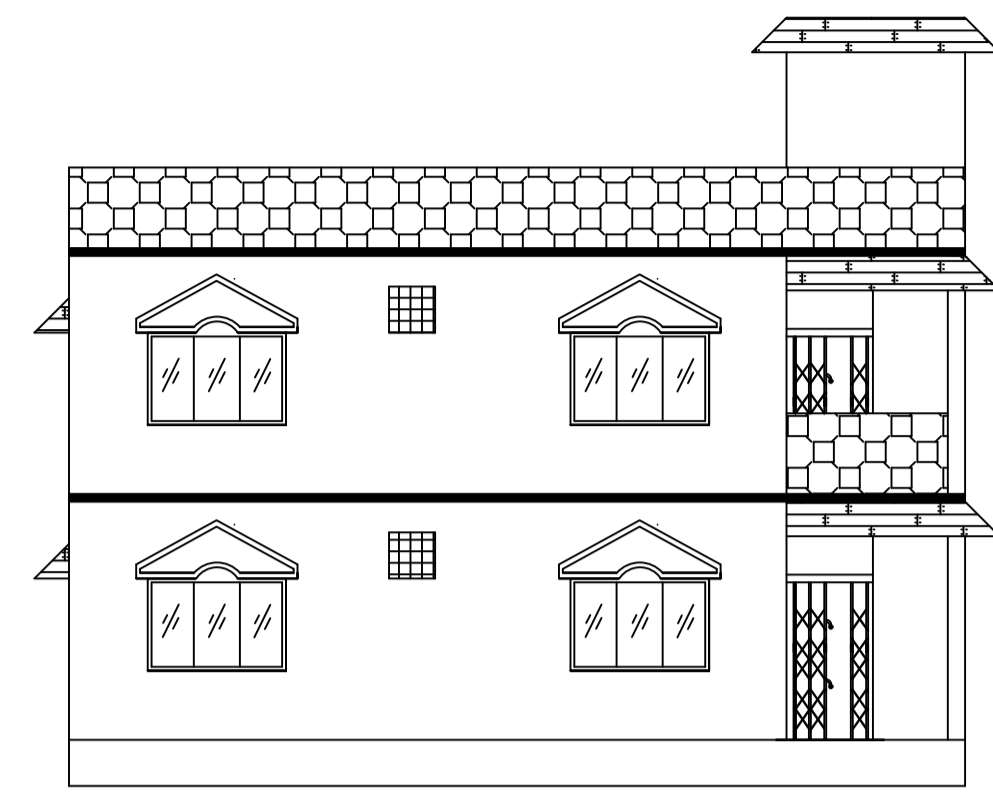

LEFT SIDE ELEVATION

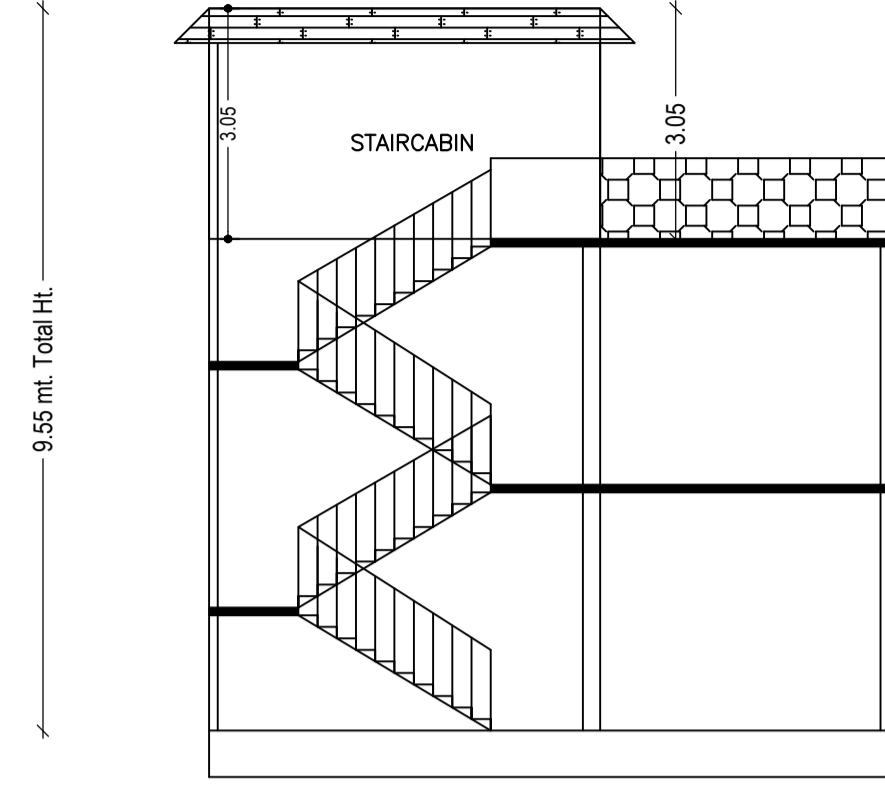

SECTION ON XX

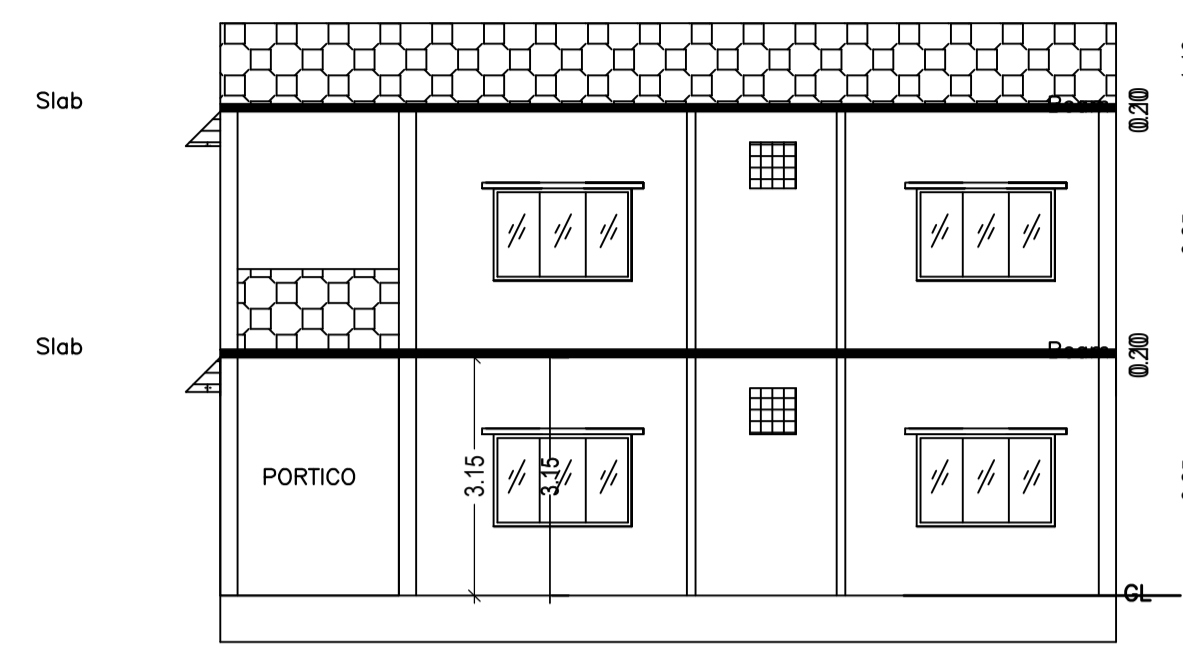

SECTION ON YY

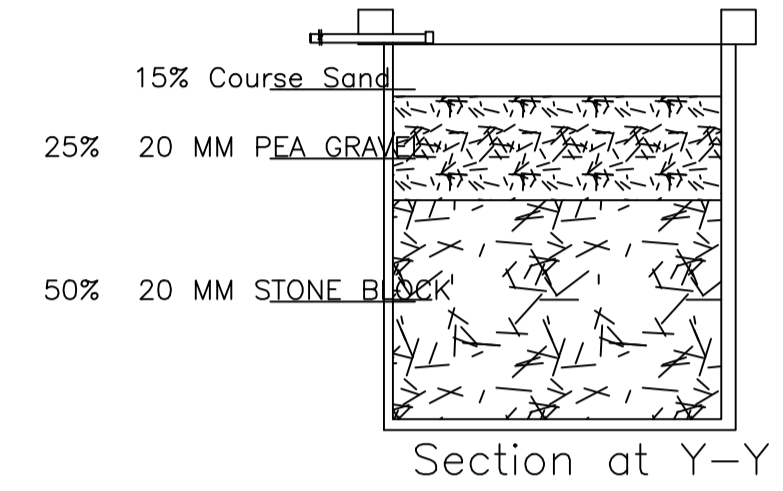

Section at Y-Y

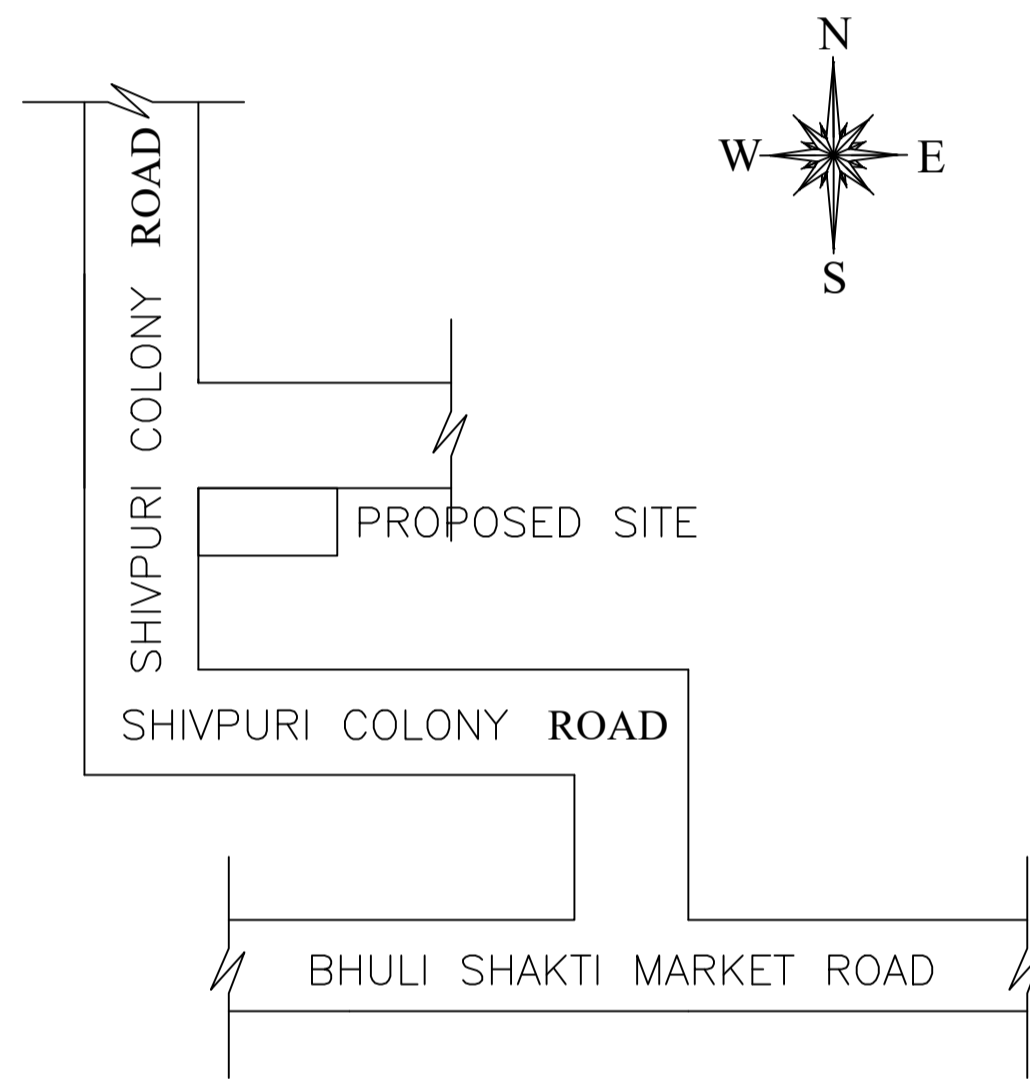

LOCATION PLAN

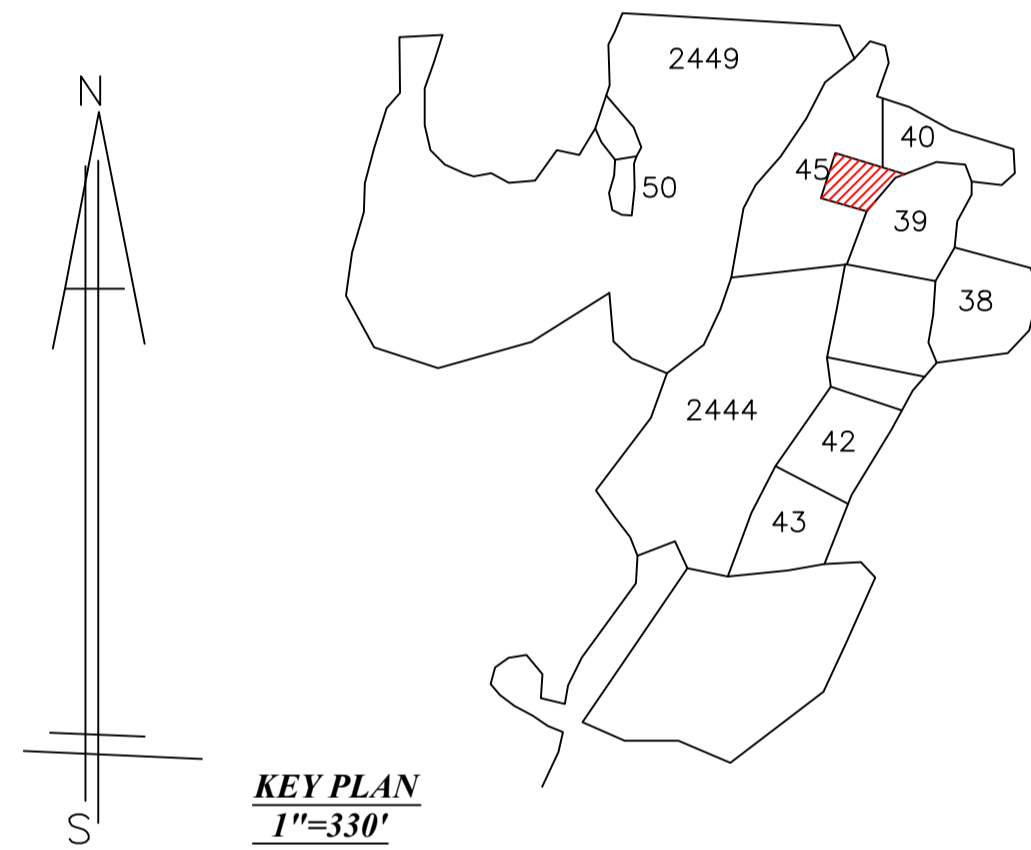

KEY PLAN
1"=330'

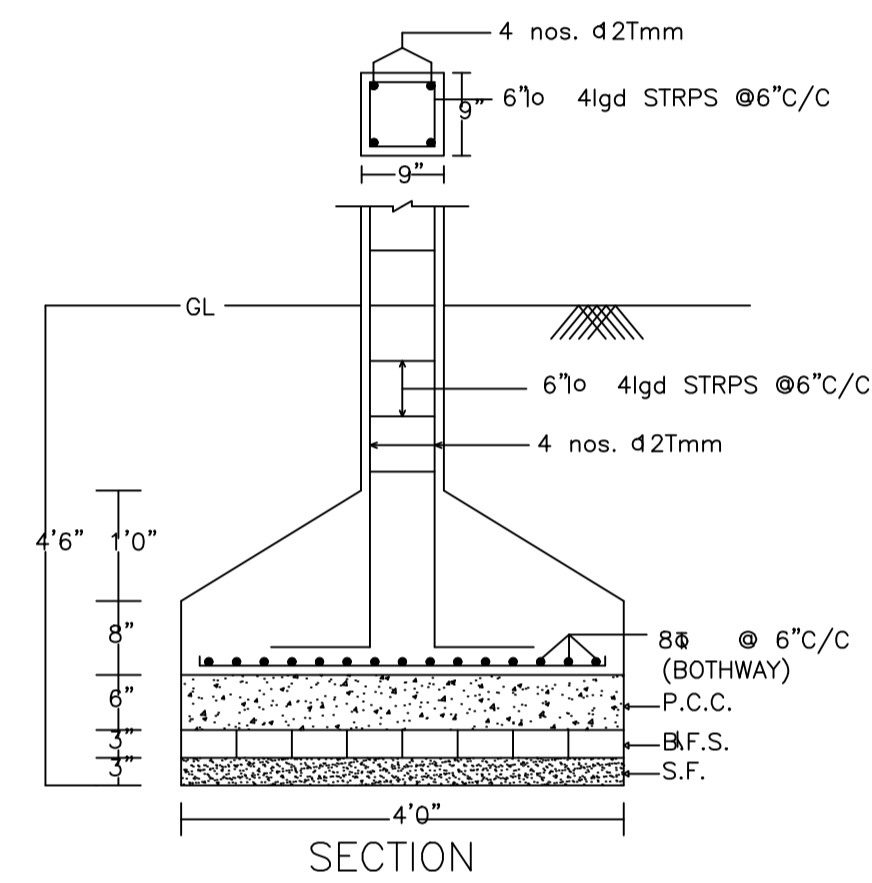

DETAIL OF COLUMNS

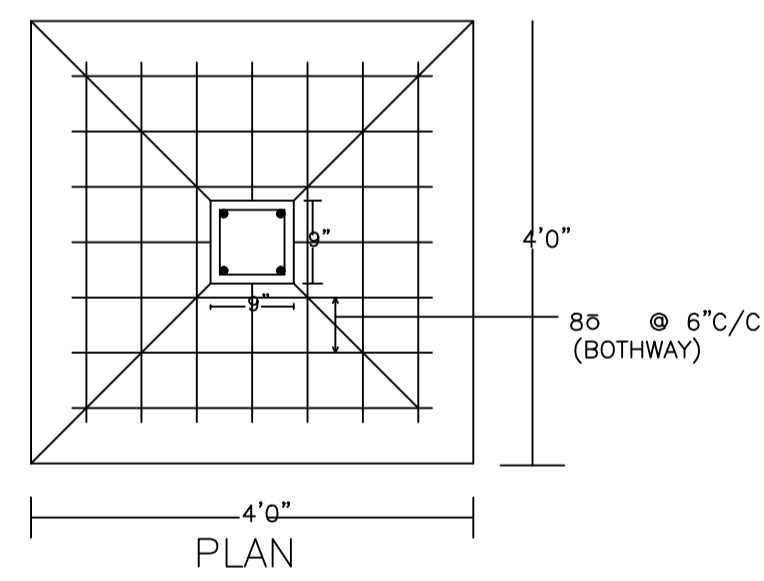

PLAN

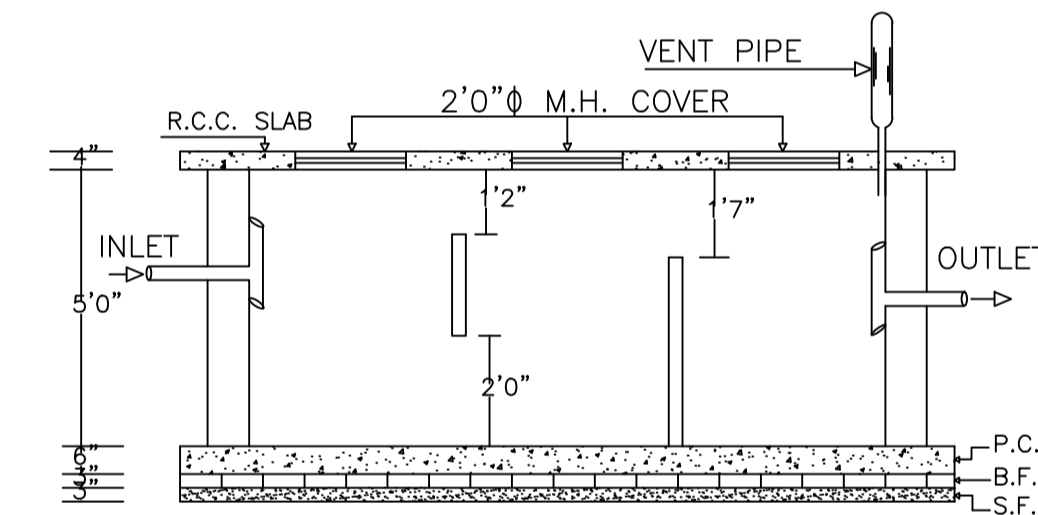

PLAN OF RECHARGE WELL
WATER HARVESTING
Scale 1" = 4' 0"

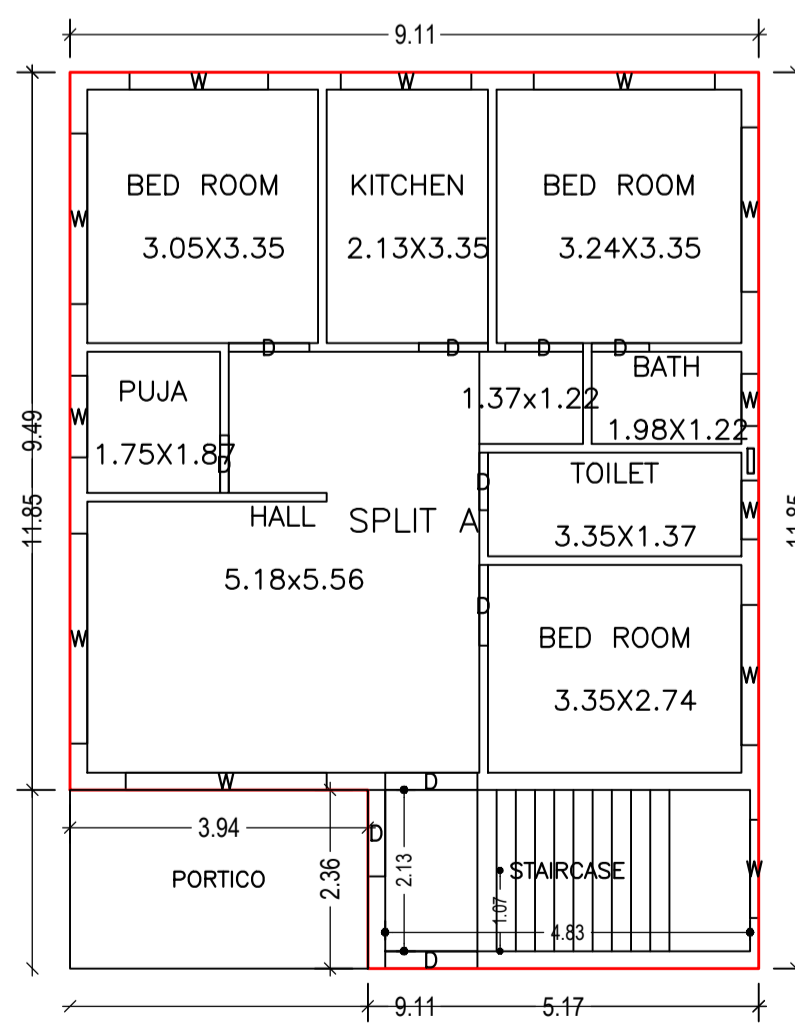

GROUND FLOOR PLAN
(Proposed)
(SCALE 1:100)

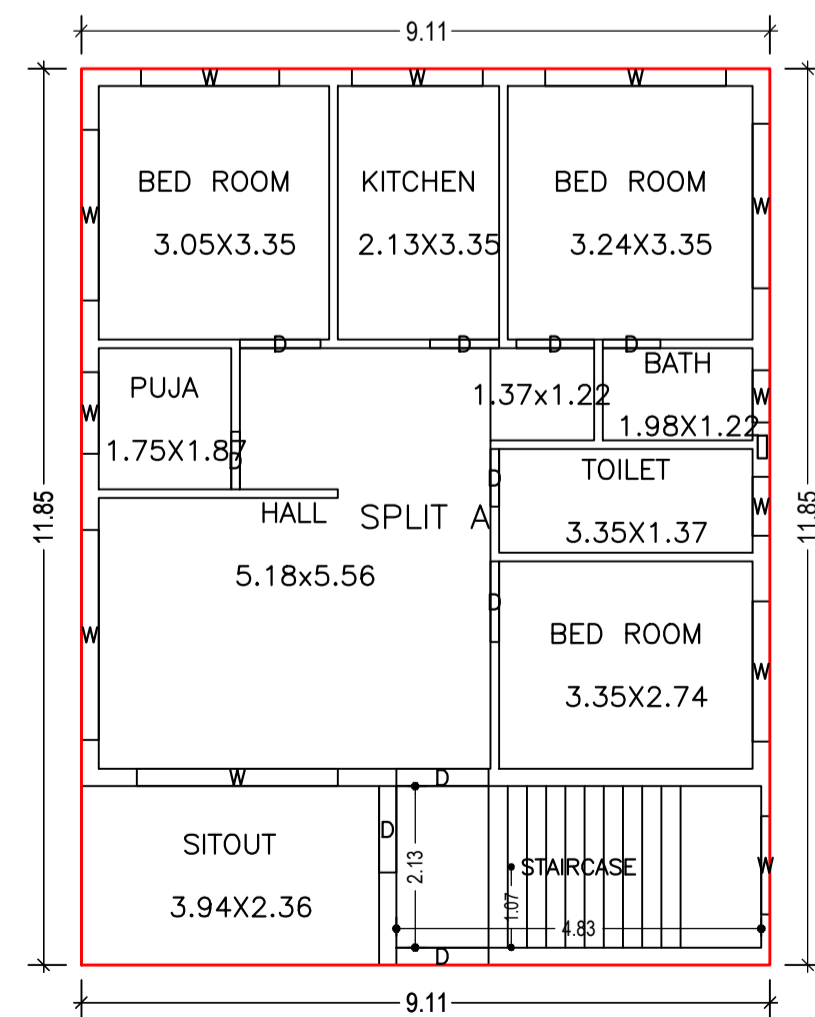

FIRST FLOOR PLAN
(Proposed)
(SCALE 1:100)

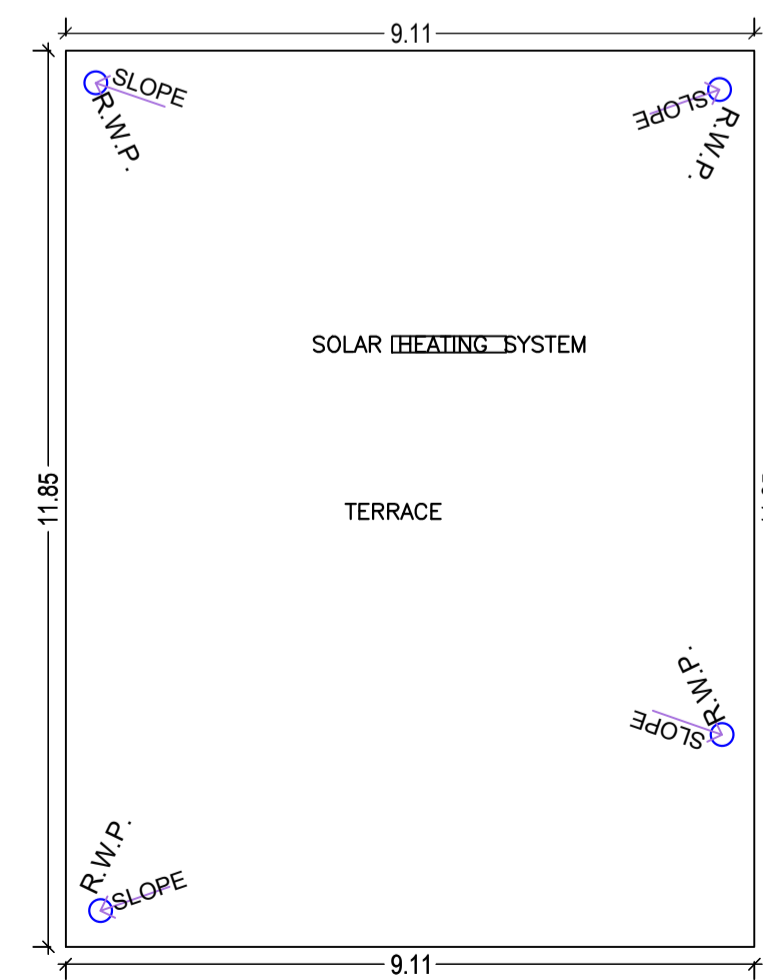

TERRACE FLOOR PLAN
(Proposed)
(SCALE 1:100)

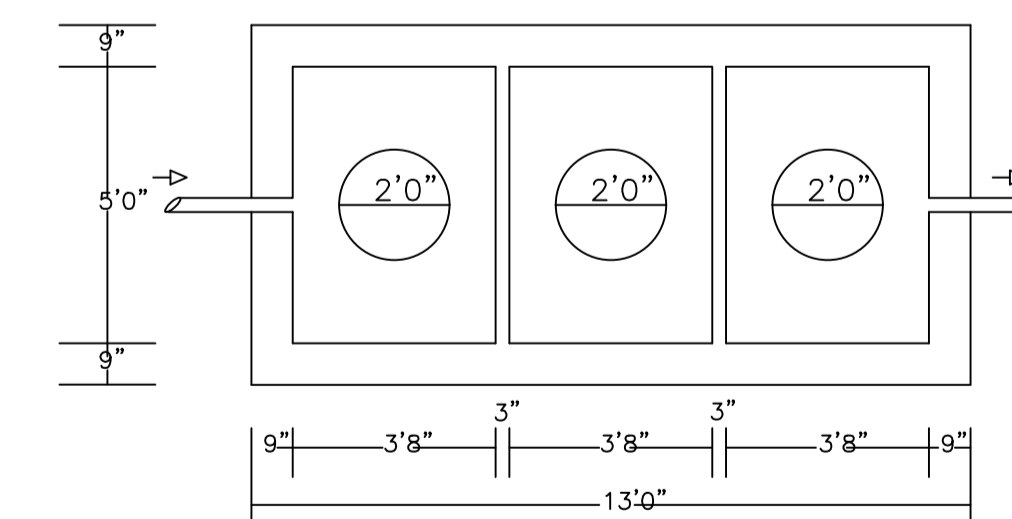

PLAN OF SEPTIC TANK
SCALE:- 1" = 4' - 0"

LTP NAME AND SIGNATURE	STRUCTURAL ENG'S NAME AND SIGNATURE	BUILDER NAME AND SIGNATURE	DIGITAL SIGNATURE
RAJEEV RANJAN SINGH DMC/ENG/0032/2017			