

Project Title : AWAPNA DEOGHARIA

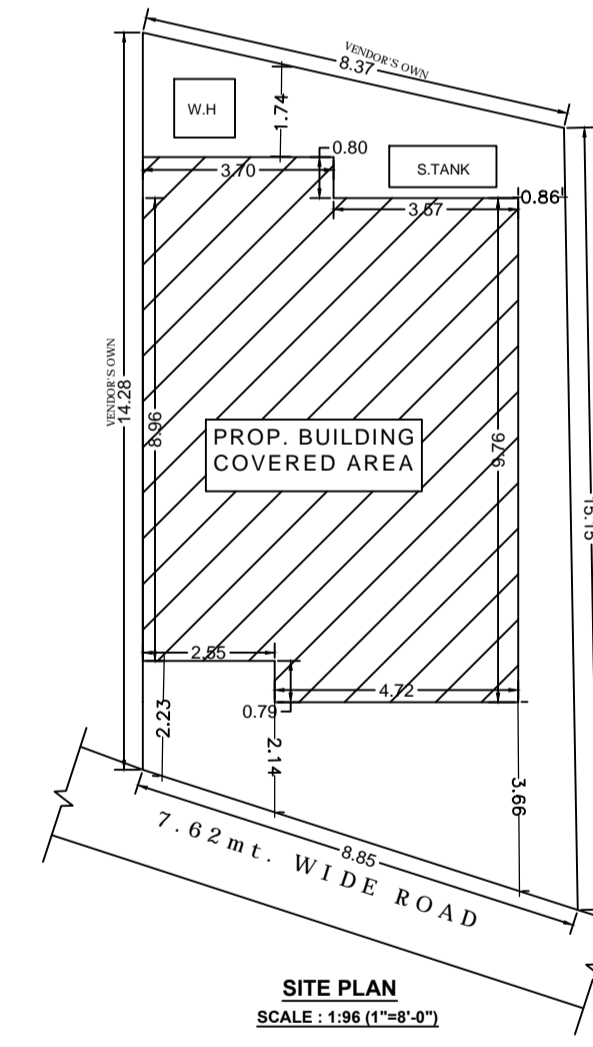
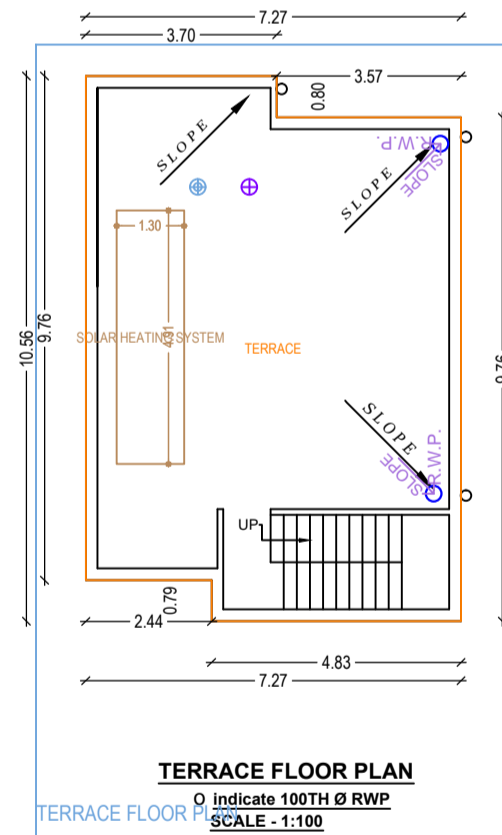
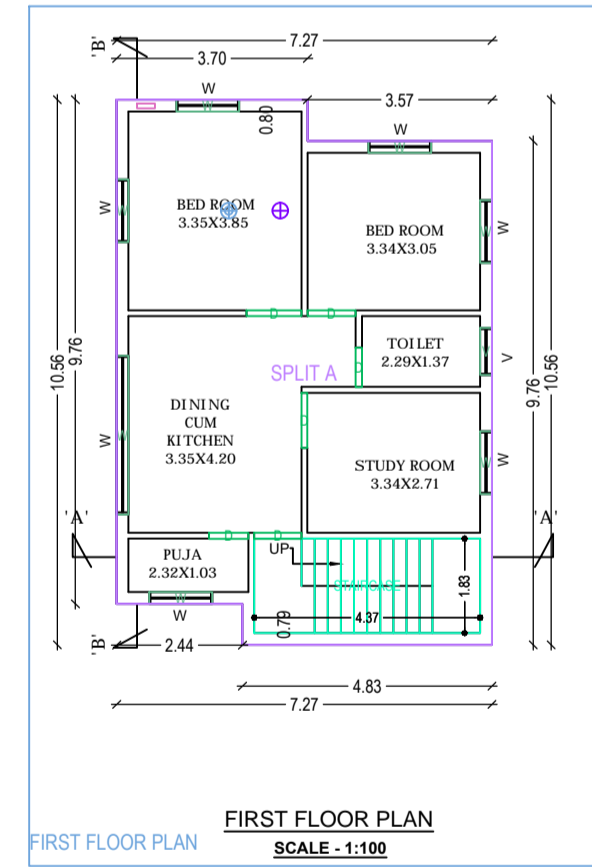
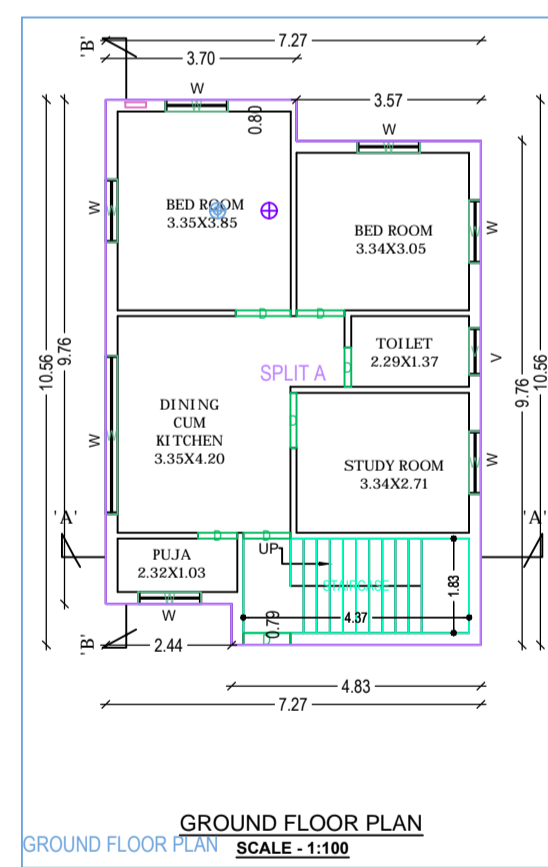
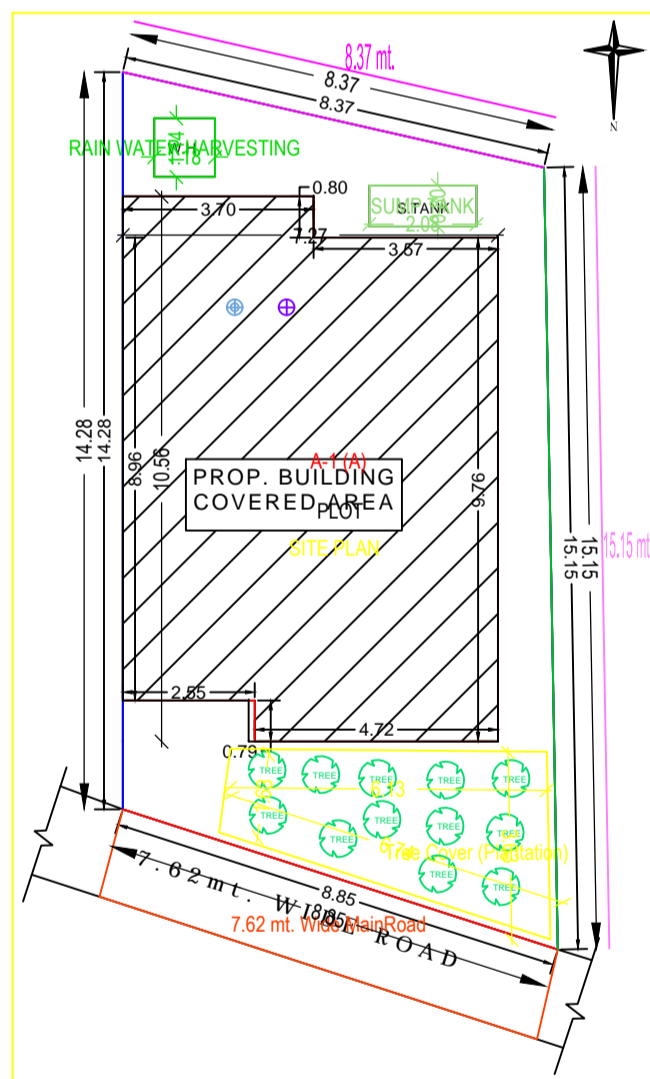
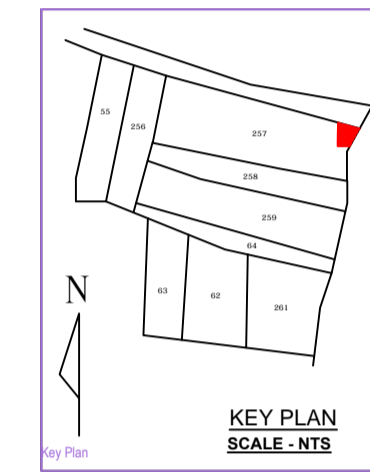
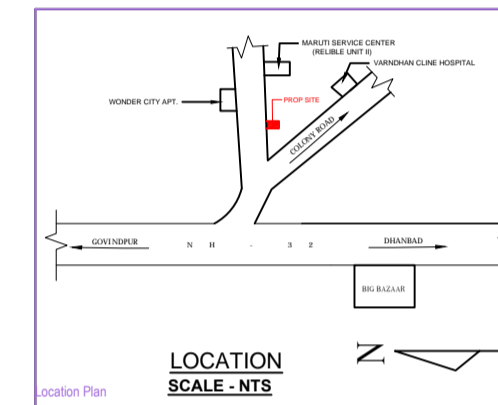
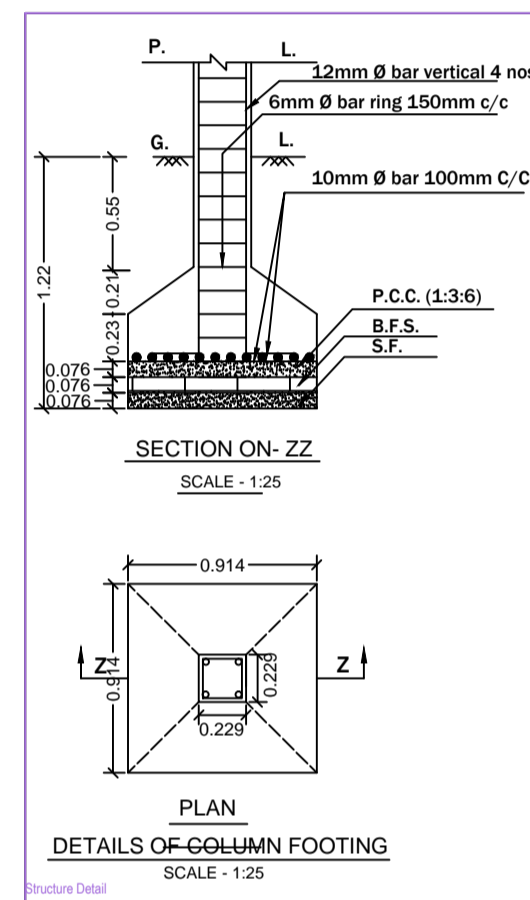
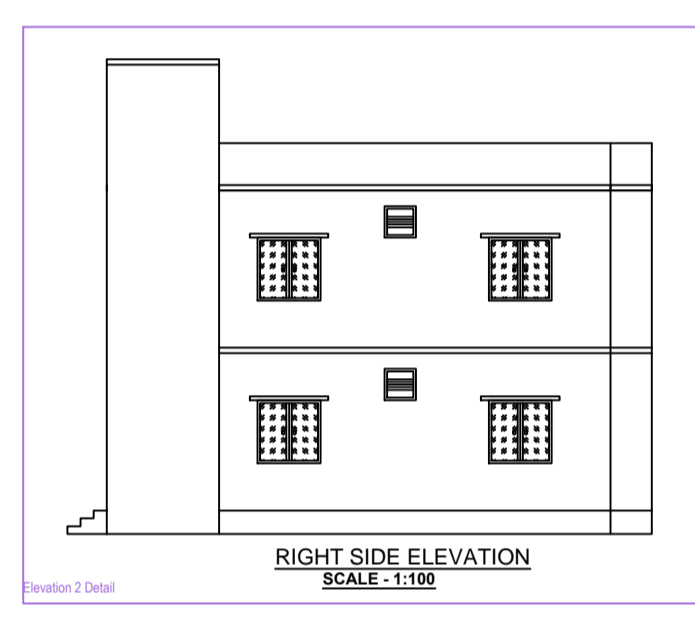
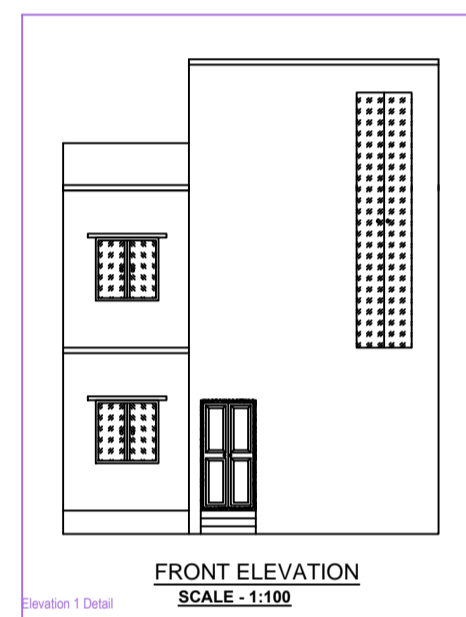
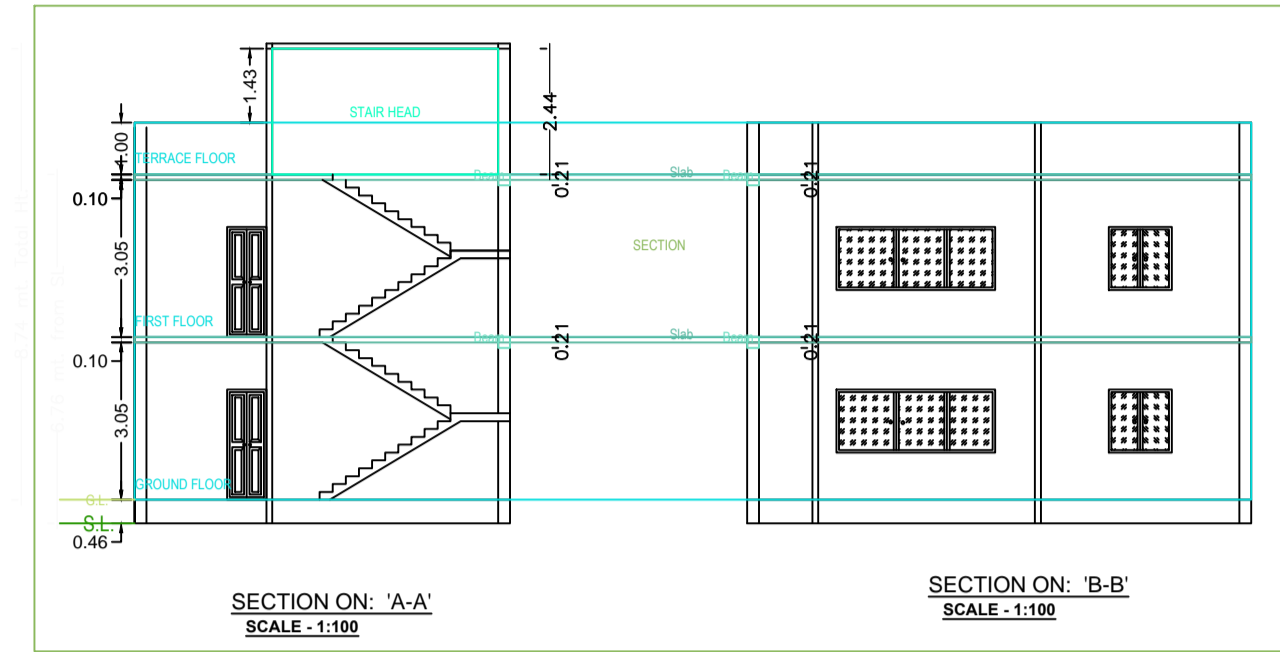
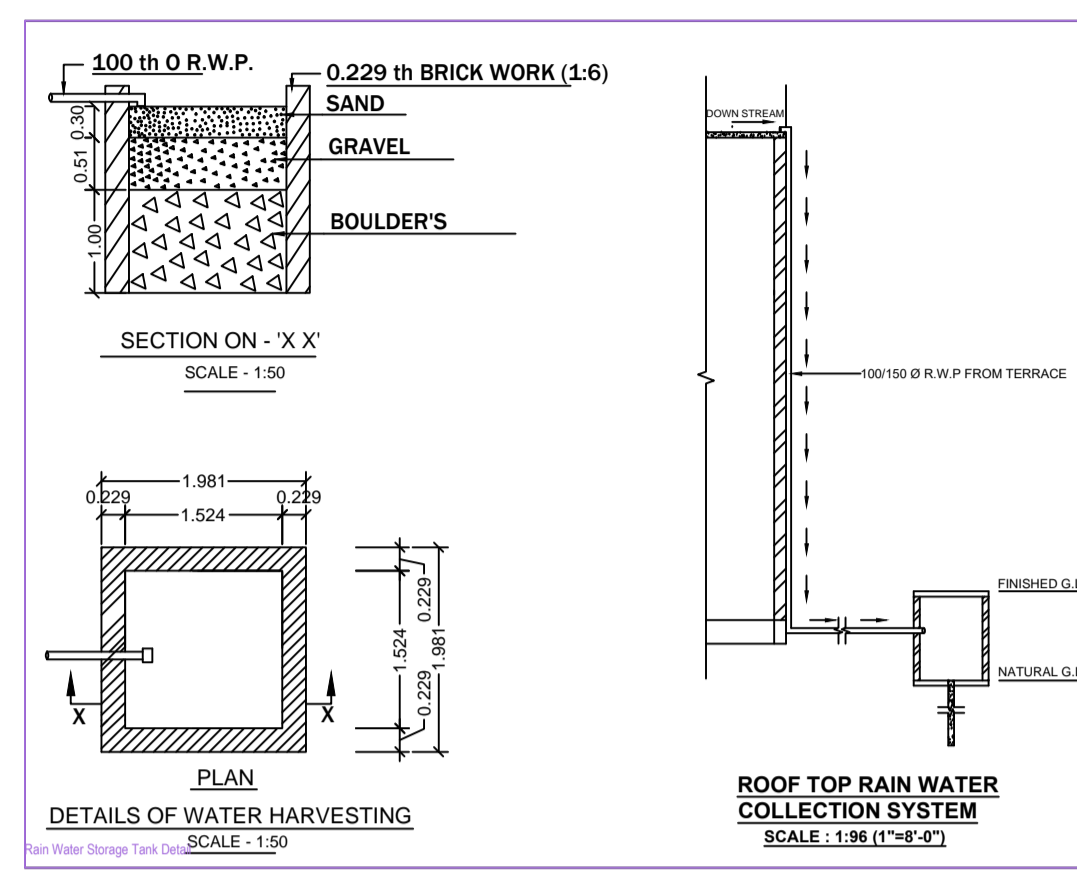
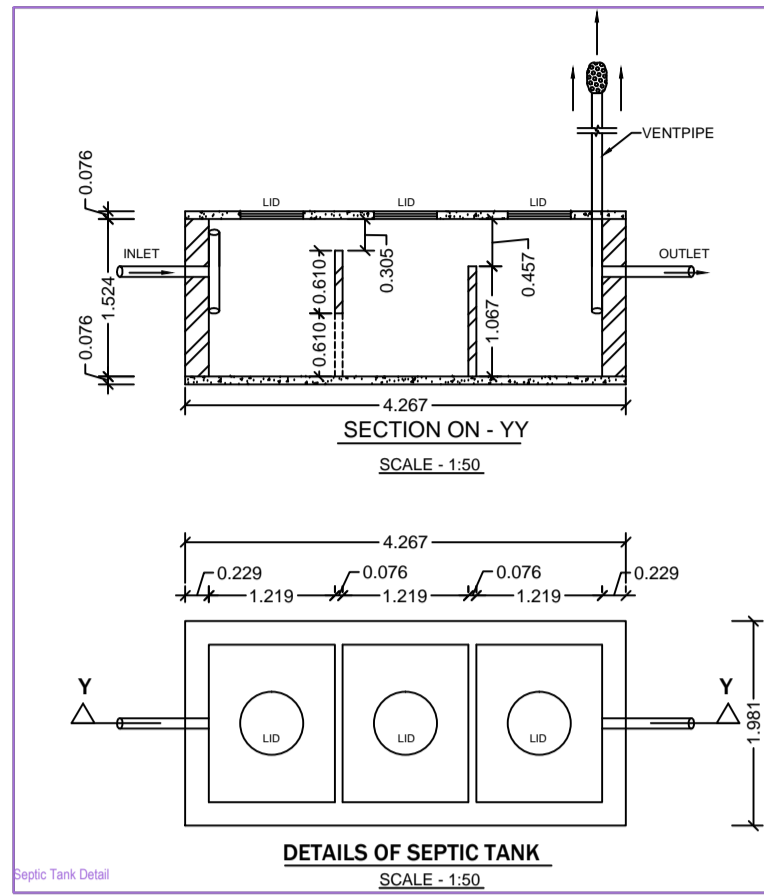
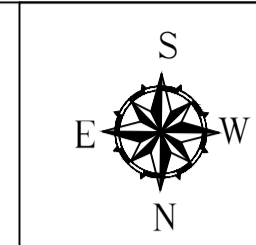

SPECIFICATION

- Dimension : All dimensions are mentioned in Meter otherwise stated.
- Excavation : As per required depth and width below the NGL.
- Foundation : As per design of Reinforced Cement Concrete/PCC.
- PCC : As per M - 10 Mix Grade with 3" thickness or noted.
- RCC : As per M - 15 (1:2:4) Mix Grade with 2" thickness or noted.
- Lintel : As per M - 15 (1:2:4) or M - 20 (1:1.5:3) Mix Grade or either noted.
- RCC : As per M - 20 (1:1.5:3) or M - 25 (1:1:2) Mix Grade or either noted.
- Steel : As per design and IS - 415 of mild / T.M.S or IS mark.
- Brick Work : First Class Brick Work with Cement Mortar 1 : 4 Mix in Foundation & Superstructure.
- Plaster Work : Cement Mortar 1 : 3 : 6 in Ceiling, 1 : 4 : 8 in Wall. Outer Wall & Inner Wall respectively with 12" thick or noted.
- Painting Work : White Wash / Sandarav on Outer side Wall and Colour Wash / Oil Based Emulsion on Inner side wall & Ceiling.
- Wood Work : W.B.M Sal Wood / Teak Wood or Standard Wood.
- Staircase : RISE - 190mm, TREAD - 250mm
- Scale : 1:100, 1:50, 1:200 & N.T.S.

SCHEDULE OF OPENING

Sl.	DOOR	D	W	Sl.	WINDOW	W
1.	DOOR	D	1.07mX2.13m	7.	WINDOW	W - 1.22mX1.22M
2.	D1	D	0.91mX2.13m	8.	W1	0.91mX1.22M
3.	D2	D	0.76mX2.13m	9.		
4.	VENTILATE	V	0.60mX0.60m	10.	ROOF LEVEL	3.05m
5.				11.		
6.				12.		

DETAILS OF AREA

1) LAND AREA (AS PER DEED):	133.78 Sqm
2) LAND AREA (AS PER SITE):	121.70 Sqm
3) GROUND FLOOR AREA:	71.95 Sqm
4) FIRST FLOOR AREA:	71.95 Sqm
5) TOTAL AREA:	143.90 Sqm
6) % OF PLINTH AREA:	59.12 %
7) FAR :	1.18

PROPOSED RESIDENTIAL BUILDING PLAN
SMT. SWAPNA DEOGHARIA W/O SRI.
PRABHAT KUMAR DEOGHARIA ON PLOT NO-
OLD 257 (NEW 718) UNDER KHATA NO-OLD 75
(NEW 301) IN MOUZA - KOLAKUSMA, MOUZA
NO-12 IN DISTRICT OF DHANBAD.

AREA STATEMENT (DHANBAD MUNICIPAL CORPORATION)

VERSION NO: 1.0.30
VERSION DATE: 16/10/2020

PROJECT DETAIL:
Project No.:
Region : DHANBAD URBAN LOCAL BODIES
District : DHANBAD
Application Type: General Proposal
Project Type: Building Permission
Nature of Development: New
Location: Old Area
Site Location: NA
Village/Mouza Name: -
Ward No: -
Road/Street: -

Plot Use: Residential
Land Use Zone: NA
Abutting Road Width: -
Plot No.:
Revenue Survey No/Survey No: -
Theme No: -
Khasra No: -
North: -
South: -
East: -
West: -

AREA DETAILS:

AREA OF PLOT (Minimum)	(A)	121.71
Net Plot Area (Gross Plot Area - Deduction from Gross Plot Area)	(A-Deductions)	121.71
CGP Area		16.54
Total		16.54
Balance Plot Area (Net Plot Area - Recreational/Amenity space)	(A-Deductions)	105.17
Plot Area for Coverage (Net Plot Area)	(A-Deductions)	121.71
Plot Area for FSI (Net Plot Area - Road/Widening Area)	(A-Deductions)	121.71
COVERED AREA CHECK		
Proposed Coverage Area (59.12 %)		71.95
Total Coverage Area (59.12 %)		71.95
FAR CHECK		
Proposed Area of FAR		143.90
Total Area of FAR		143.90
BUILT UP AREA CHECK		
Total Proposed Builtup Area		143.90
ARCHT/ENGG/ SUPERVISOR (Regd)		OWNER
DEVELOPMENT AUTHORITY		LOCAL BODY

COLOR INDEX

Plot Boundary: Green
Abutting Road: Red
Proposed Work (Coverage Area): Yellow
Existing (To be retained): Blue
Existing (To be demolished): Orange

MARGIN DETAIL:

Building / Wing Name	Road Name	Front Margin	Rear Margin	Side Margin	Side Margin
A-1 (A)	7.62 m. Wide Main Road	2.00	1.52	0.00	0.91

FAR & Tenement Details (Table 4c-1)

Building	No. of Same Bldg	Total Built Up Area (Sq.mt)	Proposed FAR Area (Sq.mt) Res.	Total FAR Area (Sq.mt)	Tenmt (No.)
A(A)	1	143.90	143.90	143.90	01
Grand Total:	1	143.90	143.90	143.90	01

Building A (A)

Floor Name	Total Built Up Area (Sq.mt)	Proposed FAR Area (Sq.mt) Res.	Total FAR Area (Sq.mt)	Tenmt (No.)
Ground Floor:	71.95	71.95	71.95	01
First Floor:	71.95	71.95	71.95	00
Terrace Floor:	0.00	0.00	0.00	00
Total:	143.90	143.90	143.90	01
Total Number of Same Buildings	1			
Total:	143.90	143.90	143.90	01

SCHEDULE OF JOINERY:

BUILDING NAME	NAME	LENGTH	HEIGHT	NOS
A(A)	D	0.76	2.10	04
A(A)	D	0.91	2.10	03
A(A)	D	0.93	2.10	02
A(A)	D	1.07	2.10	04
Total				13

SCHEDULE OF JOINERY:

BUILDING NAME	NAME	LENGTH	HEIGHT	NOS
A(A)	V	1.01	1.00	02
A(A)	W	1.22	1.20	12
A(A)	W	3.08	1.20	02
Total				16

Unit/BUA Table for Building A (A)

FLOOR	Name	Unit/BUA Type	Unit/BUA Area	Capet Area	No. of Rooms	No. of Tenement
GROUND FLOOR PLAN	SPLIT A	FLAT	143.89	143.82	6	1
Total			143.89	143.82	12	1