

Proposal Basic Information	
Proposal File No.	DMC/BP/0263/W21/2021
Owner Name	NEELAM PANDEY
Khata No	90
Plot No	605, 606
Village Name	Dhaiya
Use	Residential
SubUse	Bungalow/ Dwelling / Non Apartment

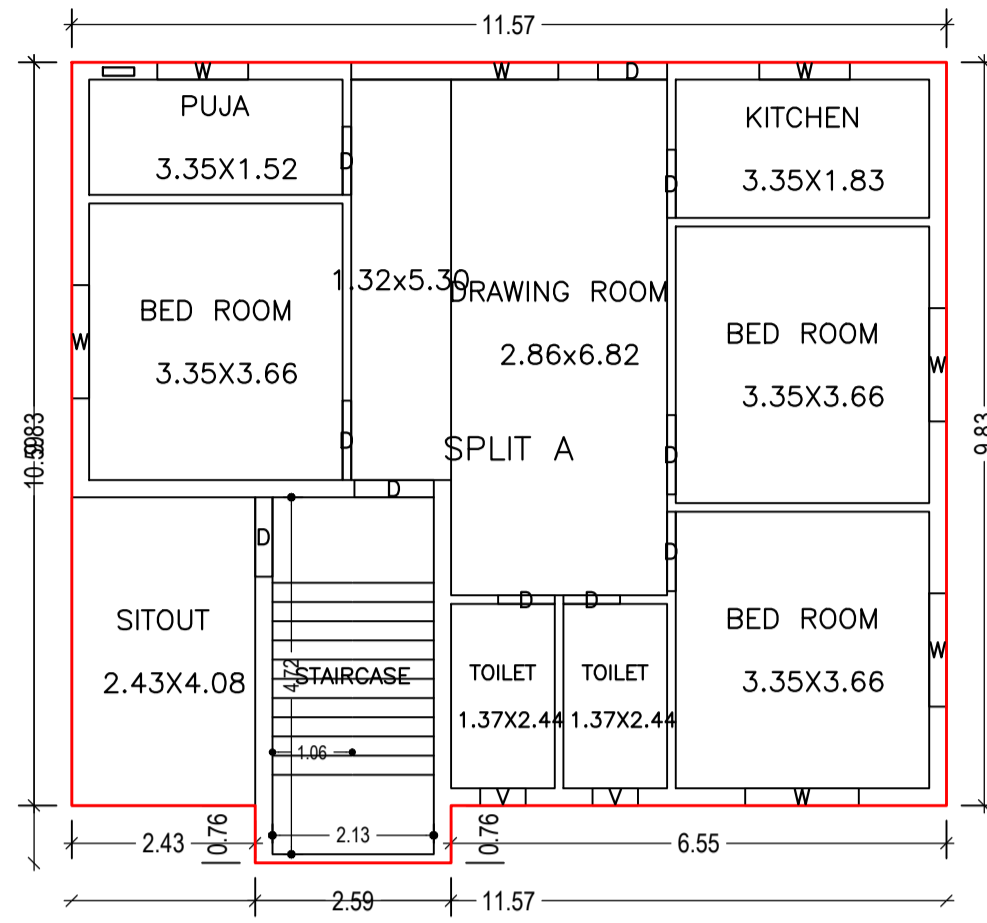

GROUND FLOOR PLAN (Proposed) (SCALE 1:100)

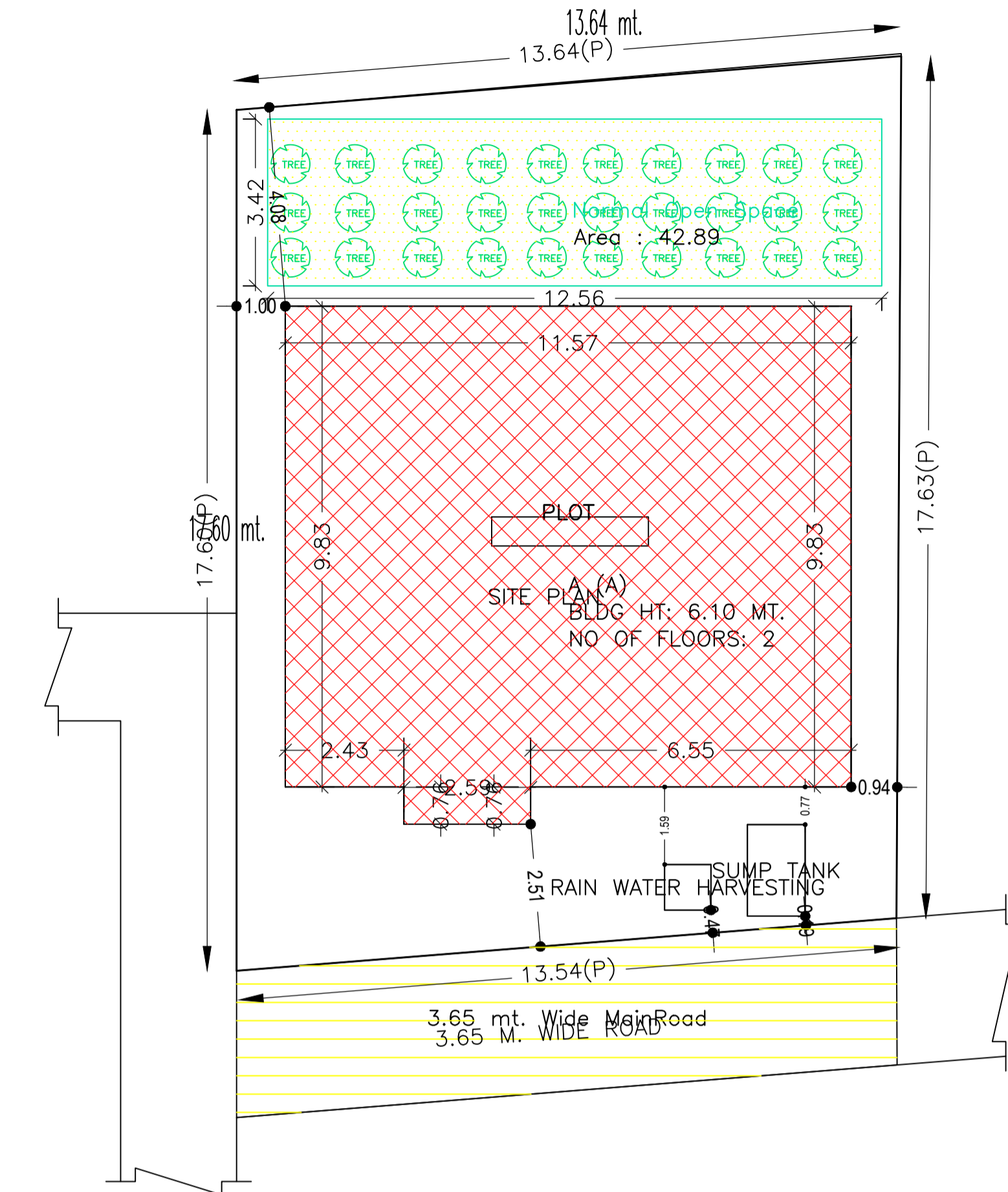
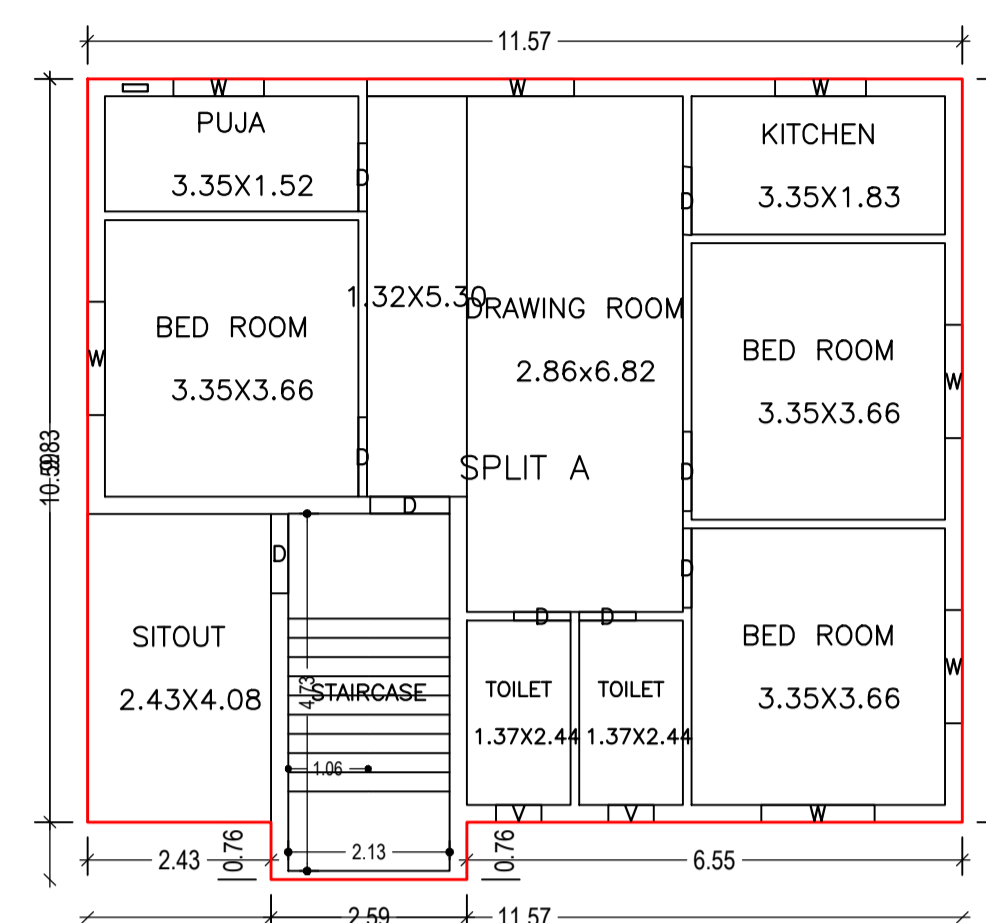

FIRST FLOOR PLAN (Proposed) (SCALE 1:100)

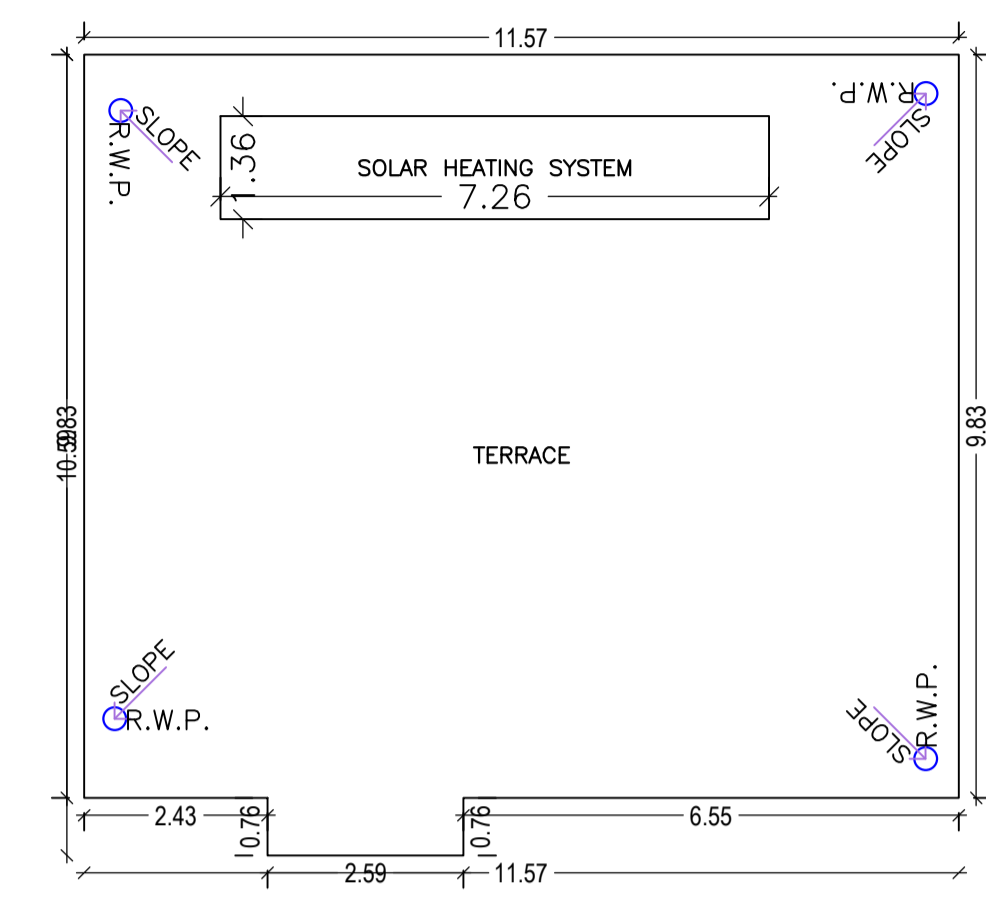

TERRACE FLOOR PLAN (SCALE 1:100)

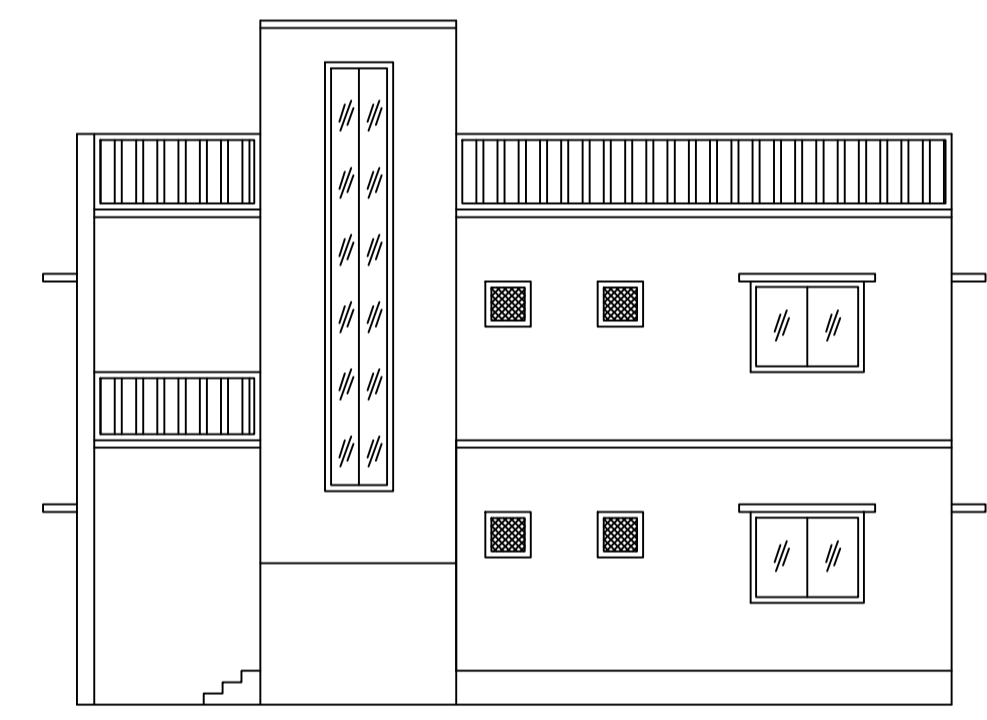

FRONT ELEVATION

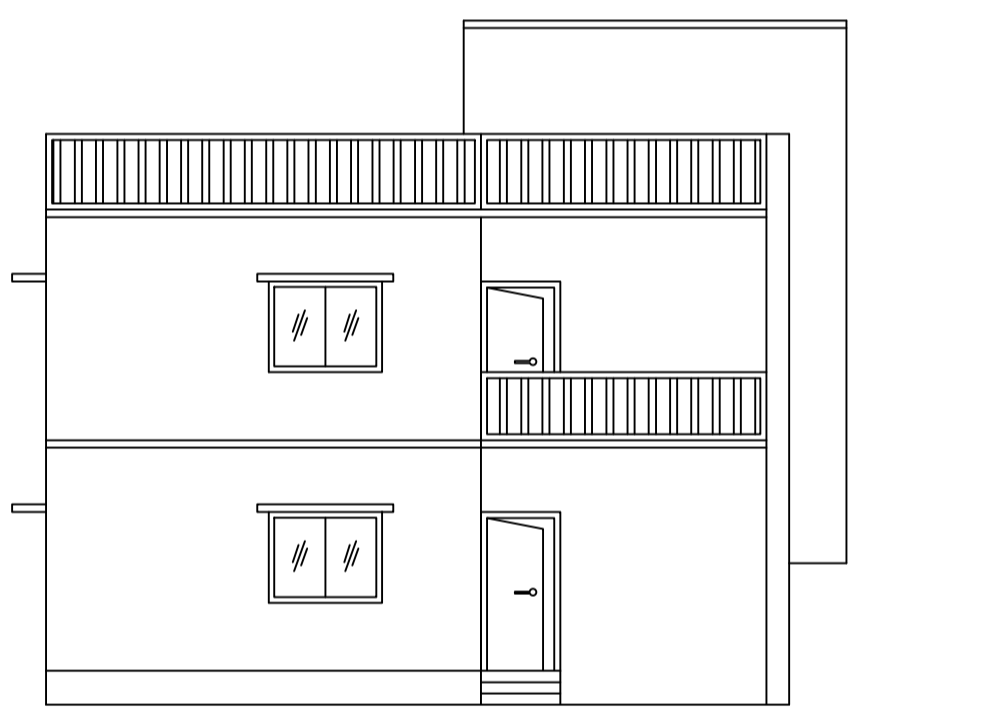

LEFT SIDE ELEVATION

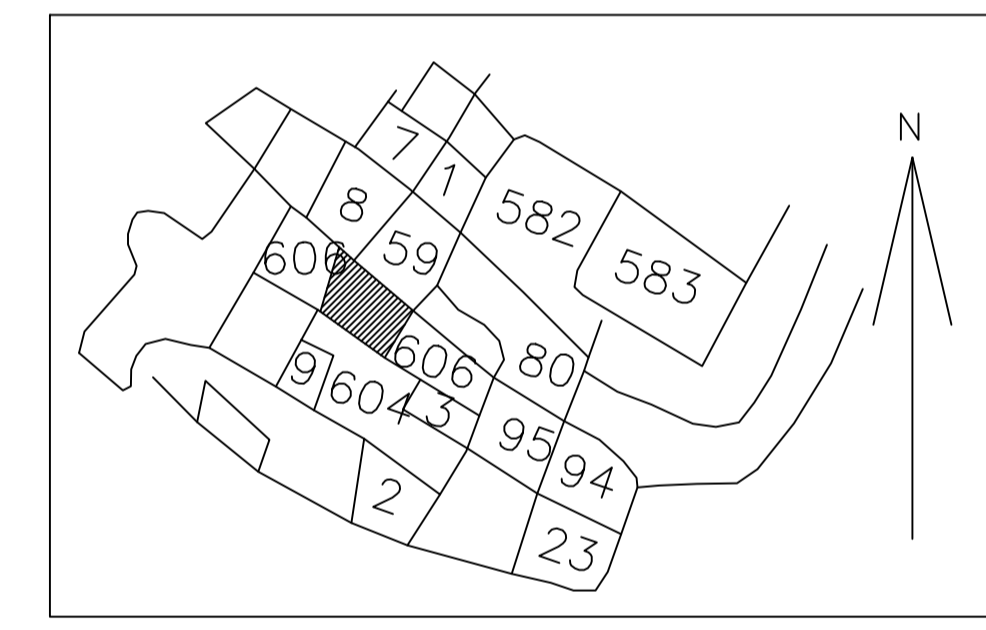

AREA STATEMENT		VERSION NO. : 1.0/61
DHANBAD MUNICIPAL CORPORATION		VERSION DATE: 16/10/2020
PROJECT DETAIL:		
Region: JHARKHAND URBAN LOCAL BODIES	Plot Use: Residential	
District: DHANBAD	Plot SubUse: Bungalow/ Dwelling / Non Apartment	
Authority: DHANBAD MUNICIPAL CORPORATION	PlotNearby/ReligiousStructure: NA	
Inward No: DMC/BP/0263/W21/2021	Plot/SubPlot No: 605, 606	
Application Type: General Proposal	North: Road Width - 4.57	
Project Type: Building Permission	South: Plot No. - KIRAN SAH	
Nature of Development: New	East: Plot No. - BABLI DEVID	
Location of Development Area: Old Area	West: Road Width - 3.65	
AREA DETAILS:		
AREA OF PLOT (Minimum)	(A)	SQ.MT. 238.50
NET AREA OF PLOT(Gross Plot Area - Deduction from Gross Plot area)	(A-Deductions)	238.50
Deduction for Balance Plot Area(from Gross Plot Area)		
Common Plot		42.89
Total		42.89
BALANCE AREA OF PLOT(Net Plot Area - Recreational/Amenity space)	(A-Deductions)	195.61
PLOT AREA FOR COVERAGE(Net Plot Area)	(A-Deductions)	238.50
Plot Area for FAR (Net Plot Area + RoadWidening Area)	(A-Deductions)	238.50
COVERAGE CHECK		
Permissible Coverage area (60.00 %)		143.10
Proposed Coverage Area (48.51 %)		115.70
Total Prop. Coverage Area (48.51 %)		115.70
Balance coverage area (11.49 %)		27.40
FAR CHECK		
Perm. FAR Area (1.50)		357.75
Total Perm. FAR area		357.75
Residential FAR		231.39
Proposed FAR Area		231.39
Total Proposed FAR Area		231.39
Consumed FAR (Factor)		0.97
Balance FAR Area		126.36
BUILT UP AREA CHECK		
Total Proposed BuiltUp Area		231.40
ARCHITECT (Regd)	SANJEEV KUMAR RAY	
ENGINEER (Regd)		
SUPERVISOR (Regd)		
OWNER (Regd)	NEELAM PANDEY	
DEVELOPMENT AUTHORITY		LOCAL BODY

COLOR INDEX	
PLOT BOUNDARY	Black
ABUTTING ROAD	Red
PROPOSED CONSTRUCTION	Green
COMMON PLOT	Yellow
ROAD WIDENING AREA	Orange
EXISTING (To be retained)	Blue
EXISTING (To be demolished)	Light Blue

Floor Name	Building Name A (A)		Total	
	Proposed Built Up Area (Sq.mt.)	Proposed FAR Area (Sq.mt.)	Total Proposed Built Up Area (Sq.mt.)	Total FAR Area (Sq.mt.)
Ground Floor	115.70	115.70	115.70	115.70
First Floor	115.70	115.70	115.70	115.70
Terrace Floor	0.00	0.00	0.00	0.00
Total :	231.40	231.40	231.40	231.40

FAR & Tenement Details (Table 4c-1)						
Building	No. of Same Bldg	Total Built Up Area (Sq.mt.)	Proposed FAR Area (Sq.mt.) Resi.	Total FAR Area (Sq.mt.)	Total Consumed Additional FAR Area (Sq.mt.)	Tnmt (No.)
A (A)	1	231.40	231.40	231.40	231.40	01
Grand Total :	1	231.40	231.40	231.40	231.40	01

Building :A (A)					
Floor Name	Total Built Up Area (Sq.mt.)	Proposed FAR Area (Sq.mt.) Resi.	Total FAR Area (Sq.mt.)	Total Consumed Additional FAR Area (Sq.mt.)	Tnmt (No.)
Ground Floor	115.70	115.70	115.70	115.70	01
First Floor	115.70	115.70	115.70	115.70	00
Terrace Floor	0.00	0.00	0.00	0.00	00
Total :	231.40	231.40	231.40	231.40	01
Total Number of Same Buildings :	1				
Total :	231.40	231.40	231.40	231.40	01

Building USE/SUBUSE Details

Building Name	Building Use	Building SubUse	Building Structure
A (A)	Residential	Residential Bldg/Apartment	Non-Highrise

SCHEDULE OF DOOR:

BUILDING NAME	NAME	LENGTH	HEIGHT	NOS
A (A)	D	0.75	2.10	04
A (A)	D	0.90	2.10	04
A (A)	D	1.05	2.10	10

SCHEDULE OF WINDOW/VENTILATION:

BUILDING NAME	NAME	LENGTH	HEIGHT	NOS
A (A)	V	0.60	1.20	04
A (A)	D	0.91	1.20	01
A (A)	W	1.20	1.20	04
A (A)	W	1.50	1.20	08
A (A)	W	2.74	1.20	02

UnitBUA Table for Building :A (A)

FLOOR	Name	UnitBUA Type	UnitBUA Area	Carpet Area	No. of Rooms	No. of Tenement
GROUND FLOOR PLAN	SPLIT A	FLAT	231.39	231.32	9	1
FIRST FLOOR PLAN	SPLIT A	FLAT	0.00	0.00	9	0
Total:			231.39	231.32	18	1

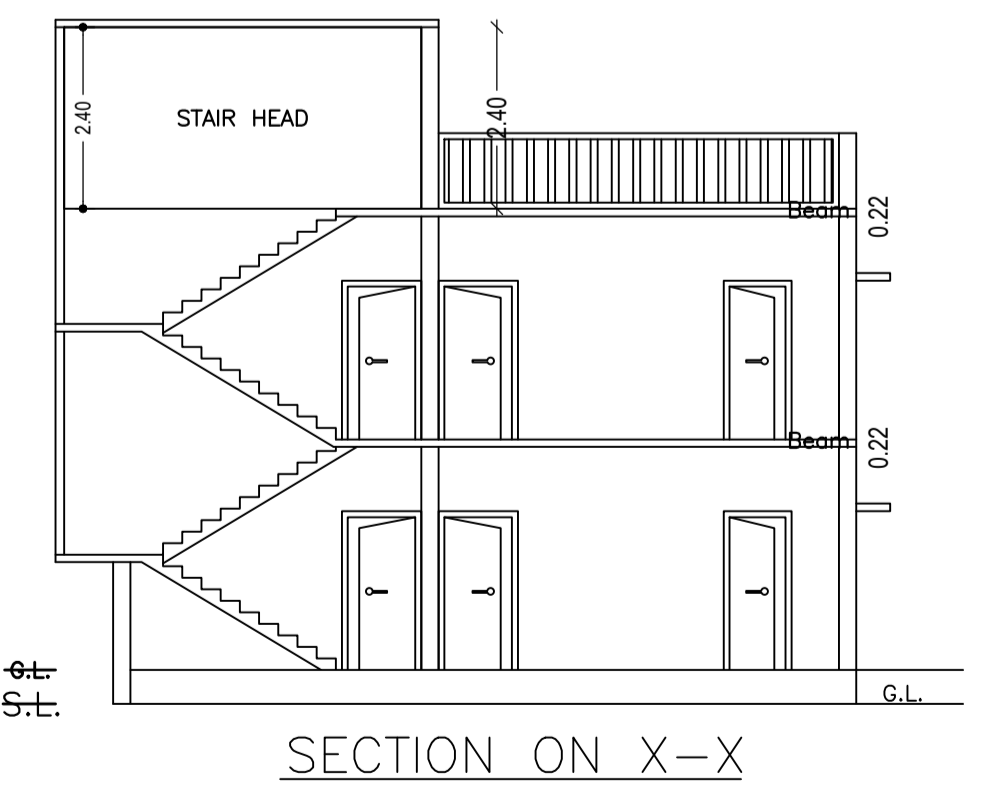

SECTION ON X-X

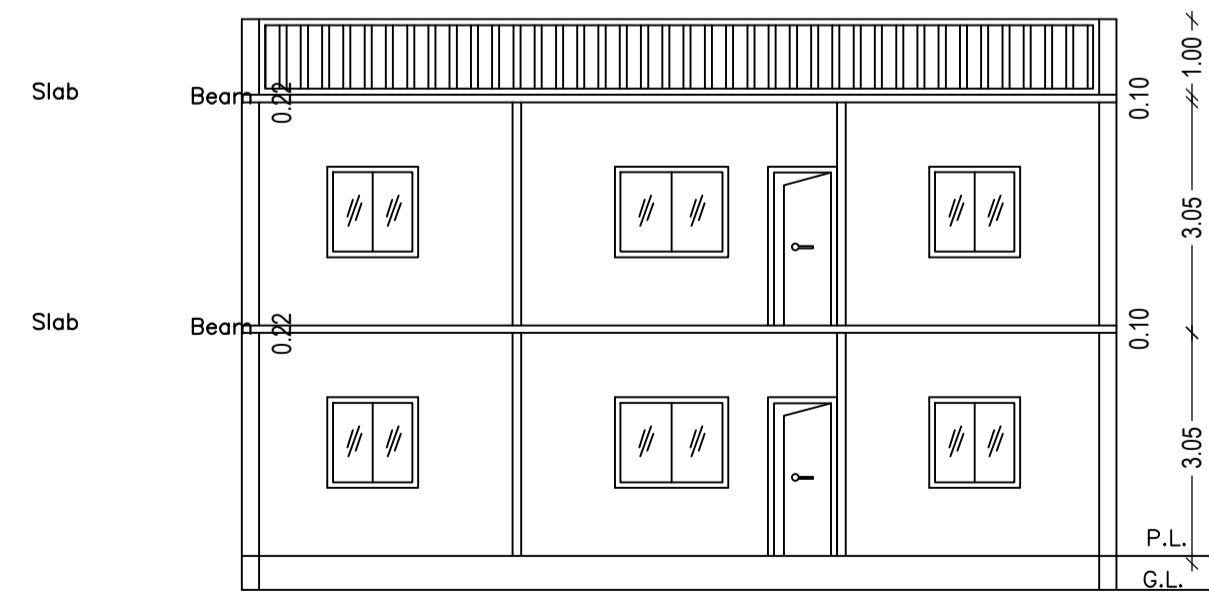

SECTION ON Y-Y

LTP NAME AND SIGNATURE	STRUCTURAL ENG'S NAME AND SIGNATURE	BUILDER NAME AND SIGNATURE	DIGITAL SIGNATURE
SANJEEV KUMAR RAY DMC/ENG/0001/2019			

Proposal Basic Information	
Proposal File No.	DMC/BP/0263/W21/2021
Owner Name	NEELAM PANDEY
Khata No	90
Plot No	605, 606
Village Name	Dhaiya
Use	Residential
SubUse	Bungalow/ Dwelling / Non Apartment

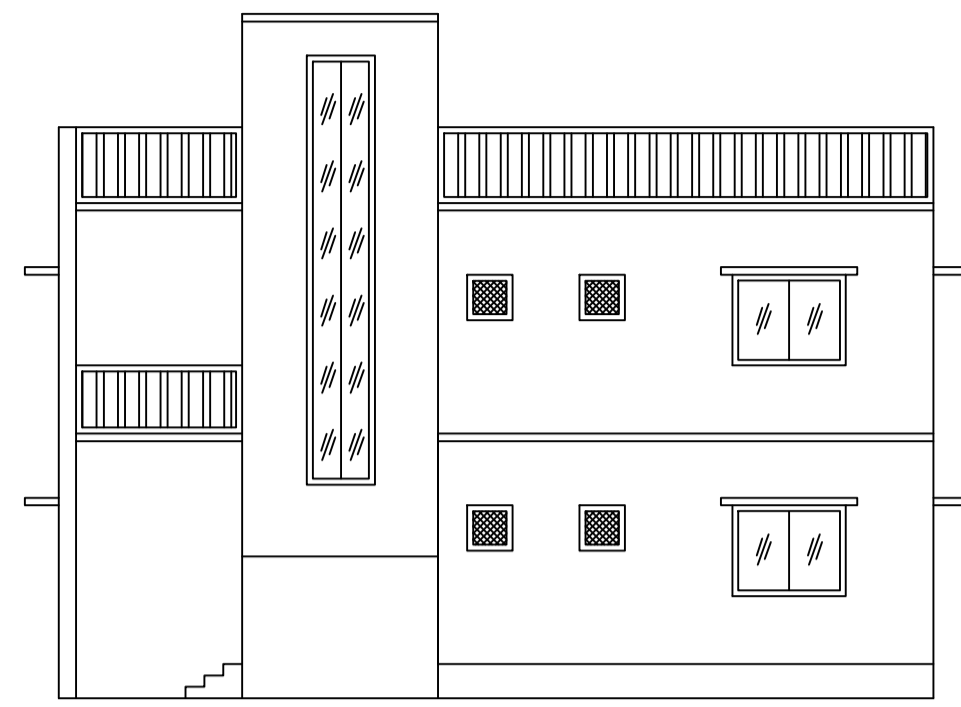

FRONT ELEVATION

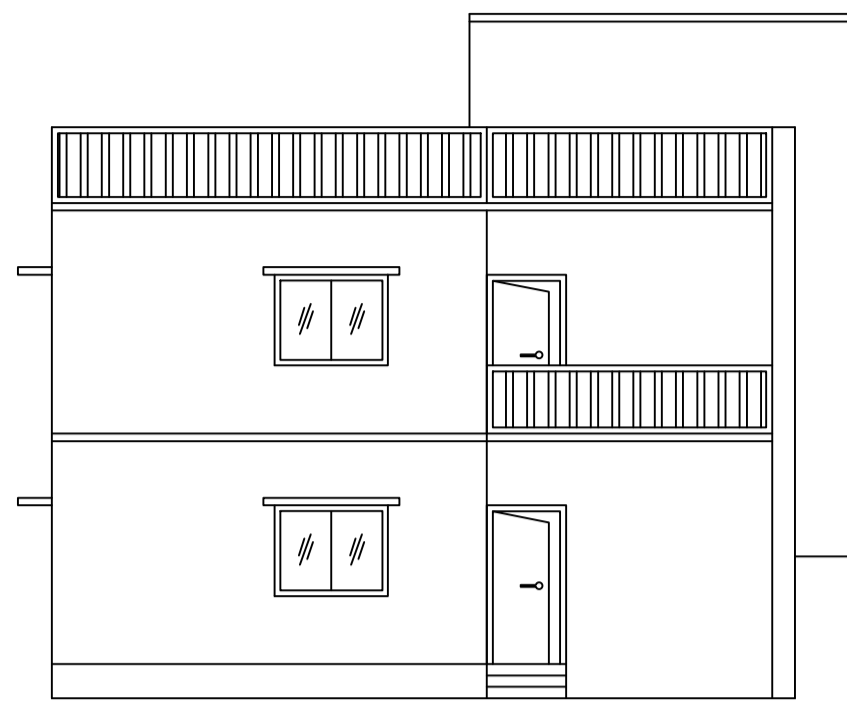

LEFT SIDE ELEVATION

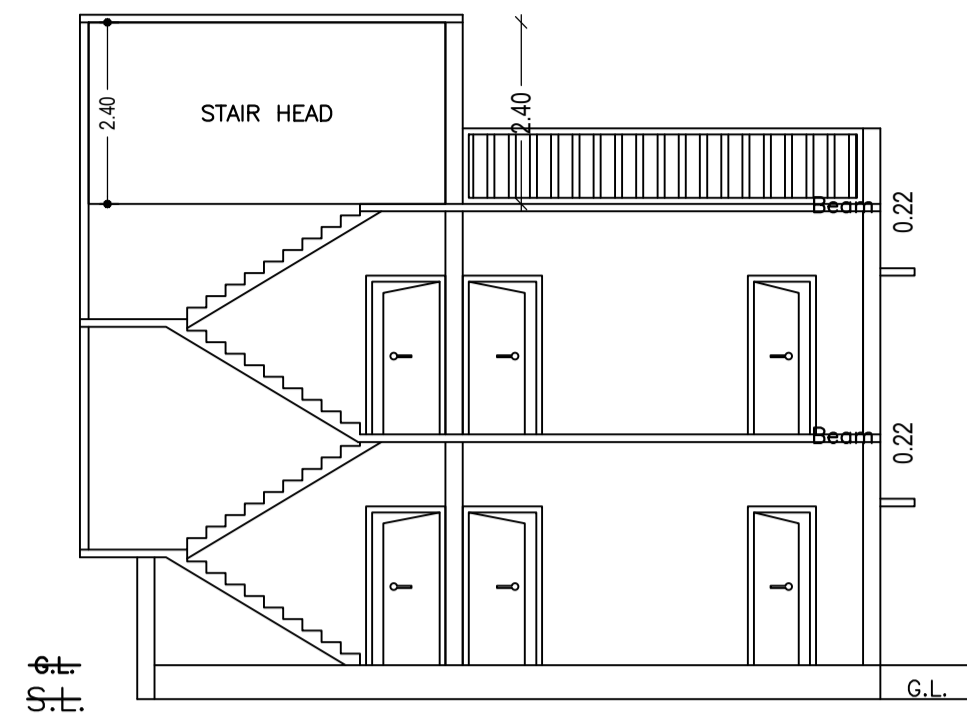

SECTION ON X-X

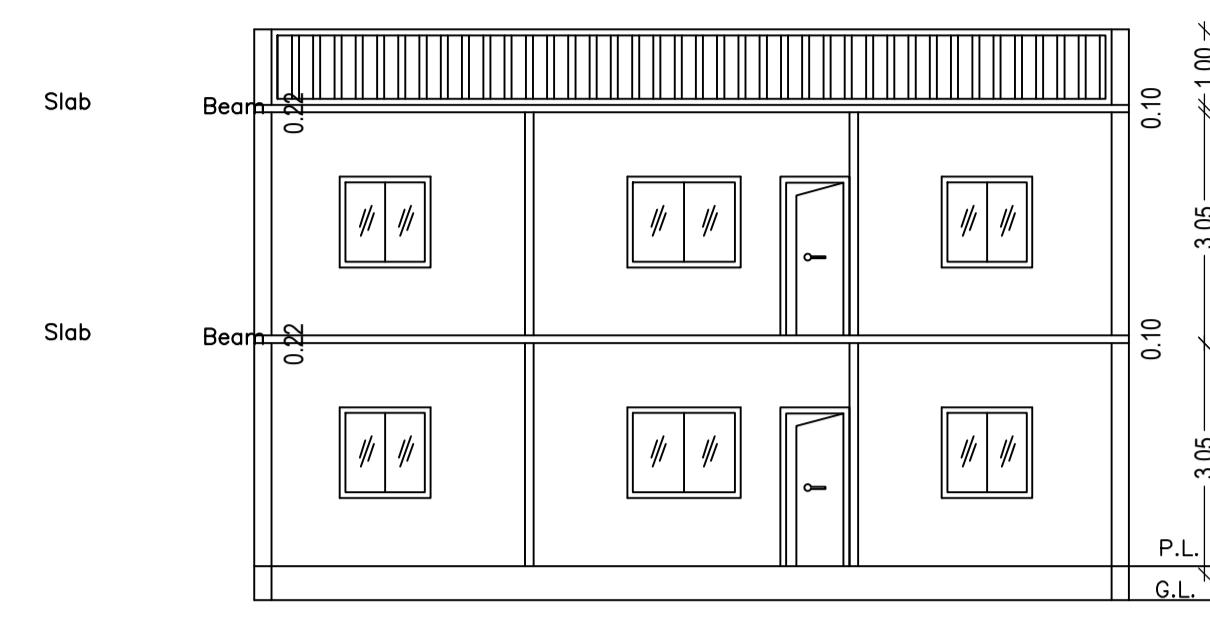

SECTION ON Y-Y

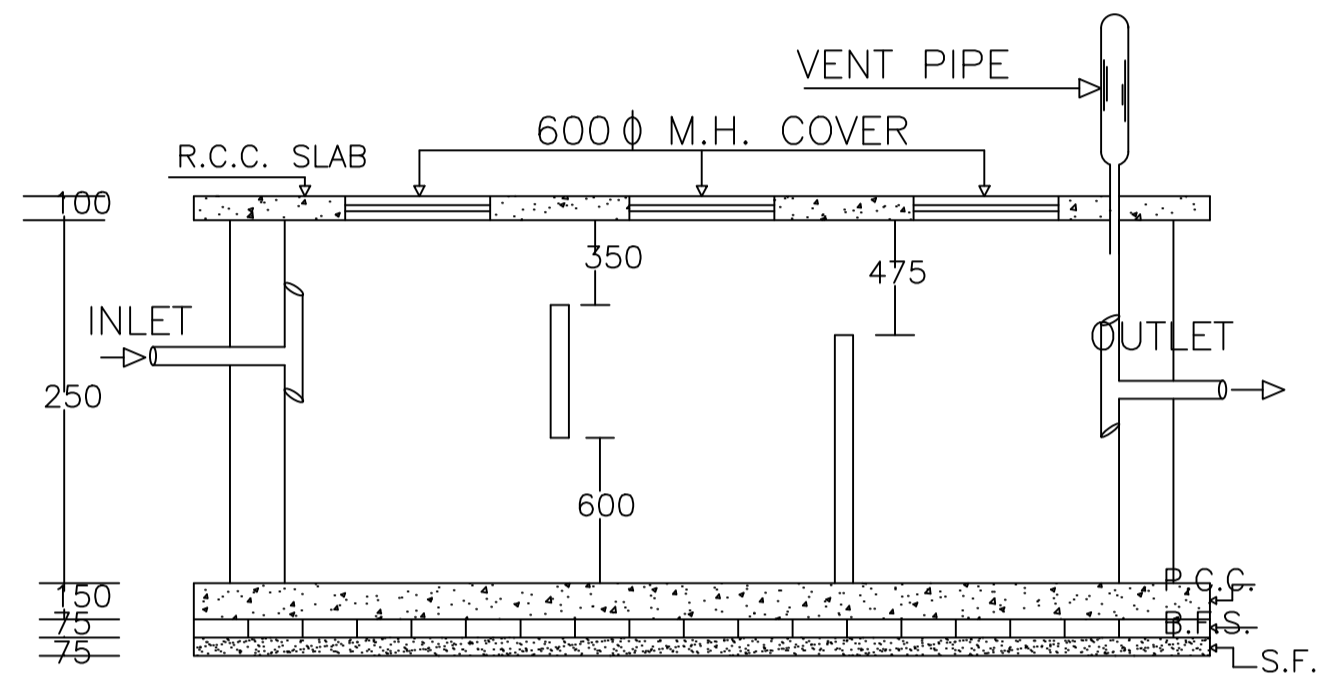

PLAN OF SEPTIC TANK

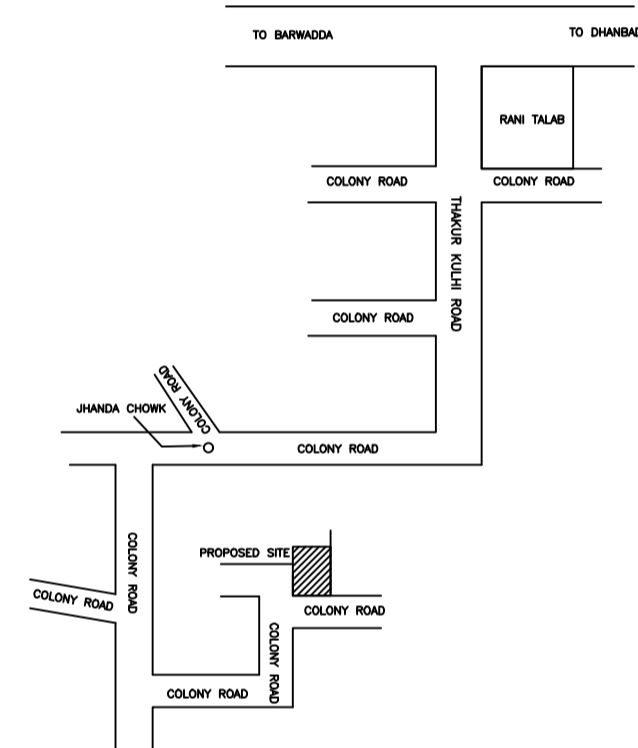

LOCATION PLAN

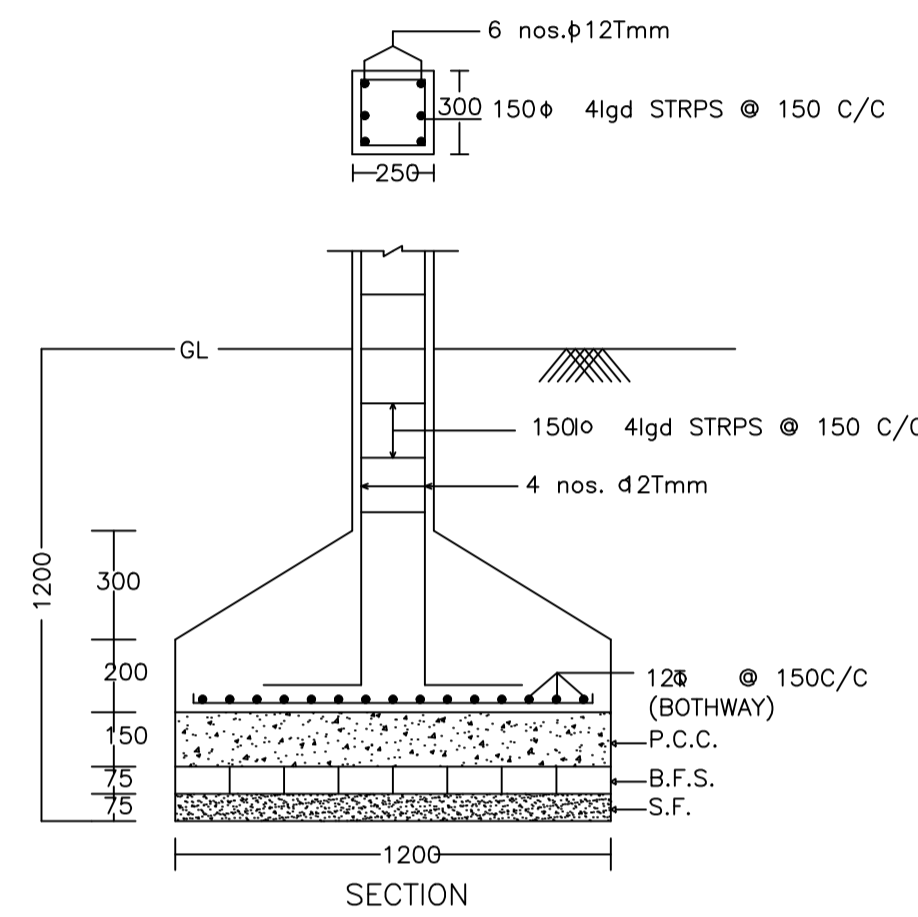

DETAIL OF COLUMNS

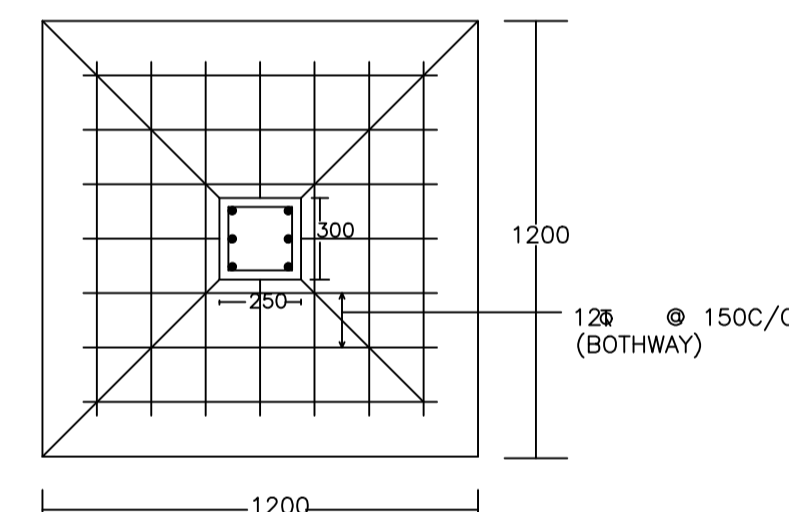

PLAN

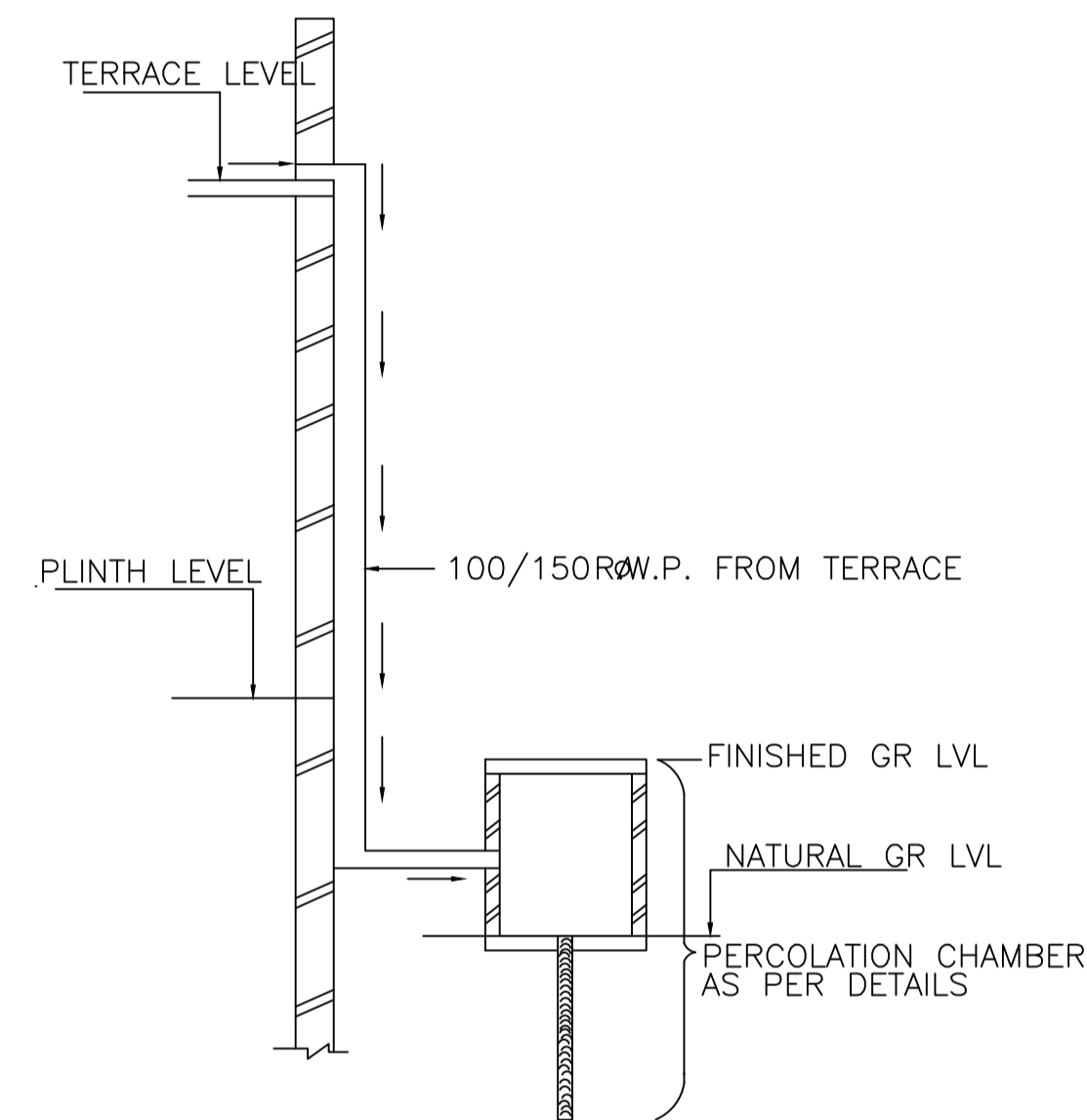

ROOF TOP RAIN WATER COLLECTION SYSTEM

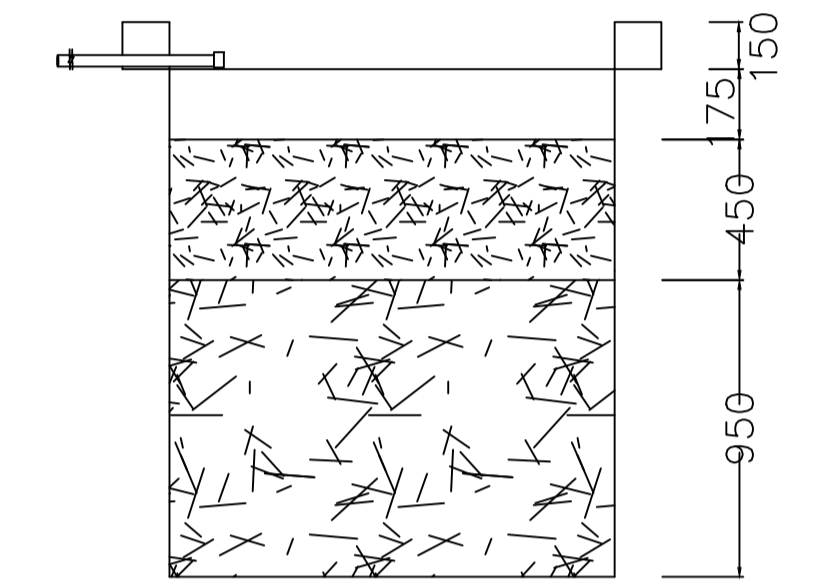

SECTION AT Y-Y

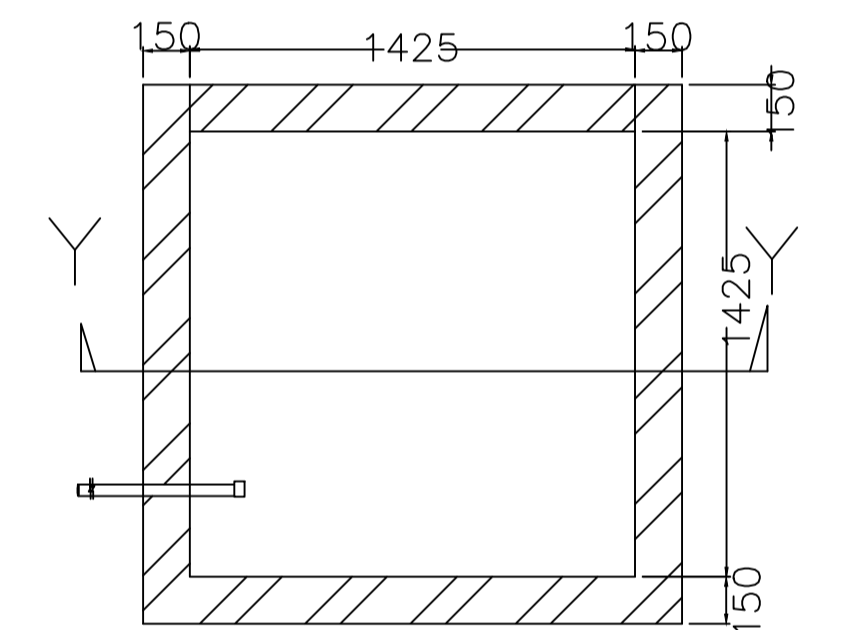

PLAN OF RECHARGE WELL WATER HARVESTING

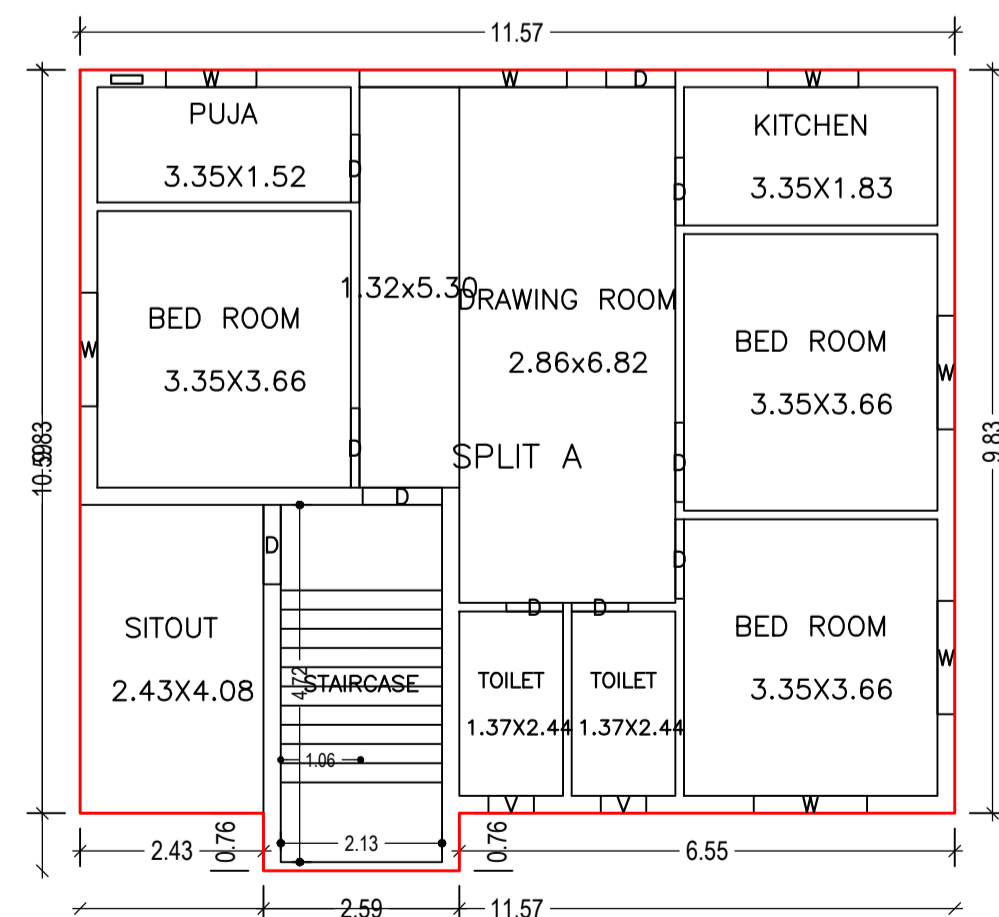

GROUND FLOOR PLAN (Proposed) (SCALE 1:100)

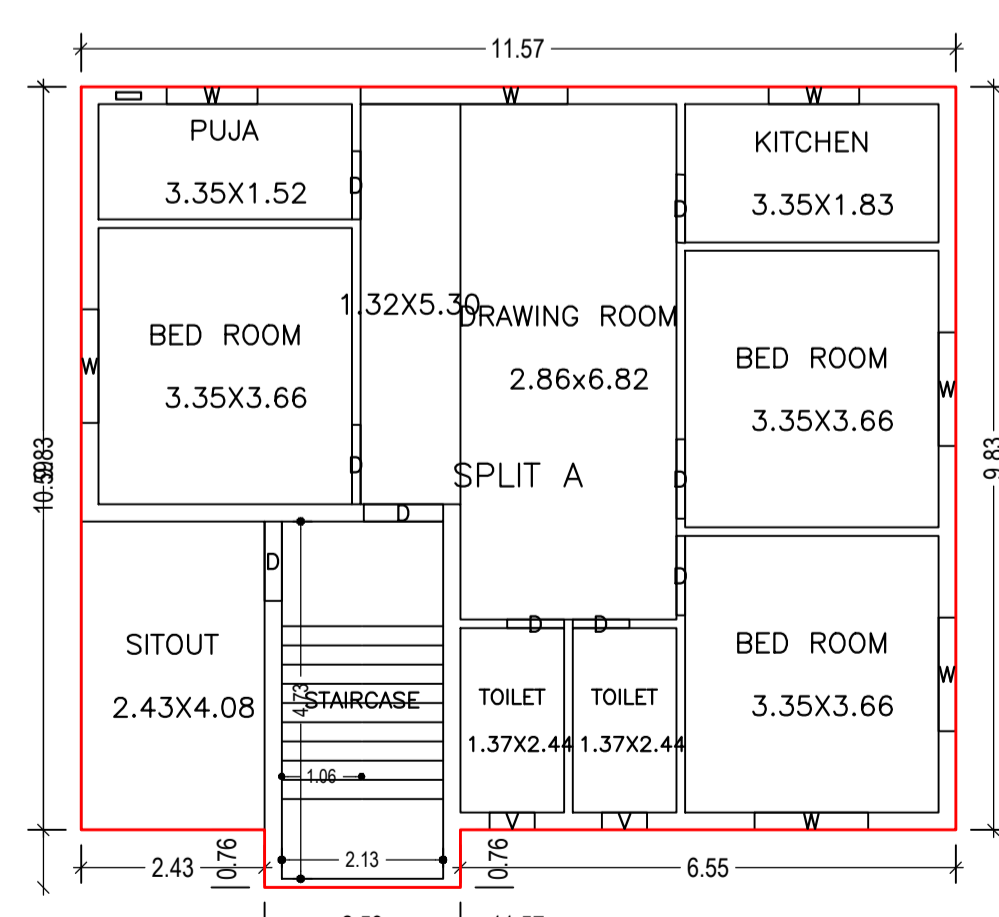

FIRST FLOOR PLAN (Proposed) (SCALE 1:100)

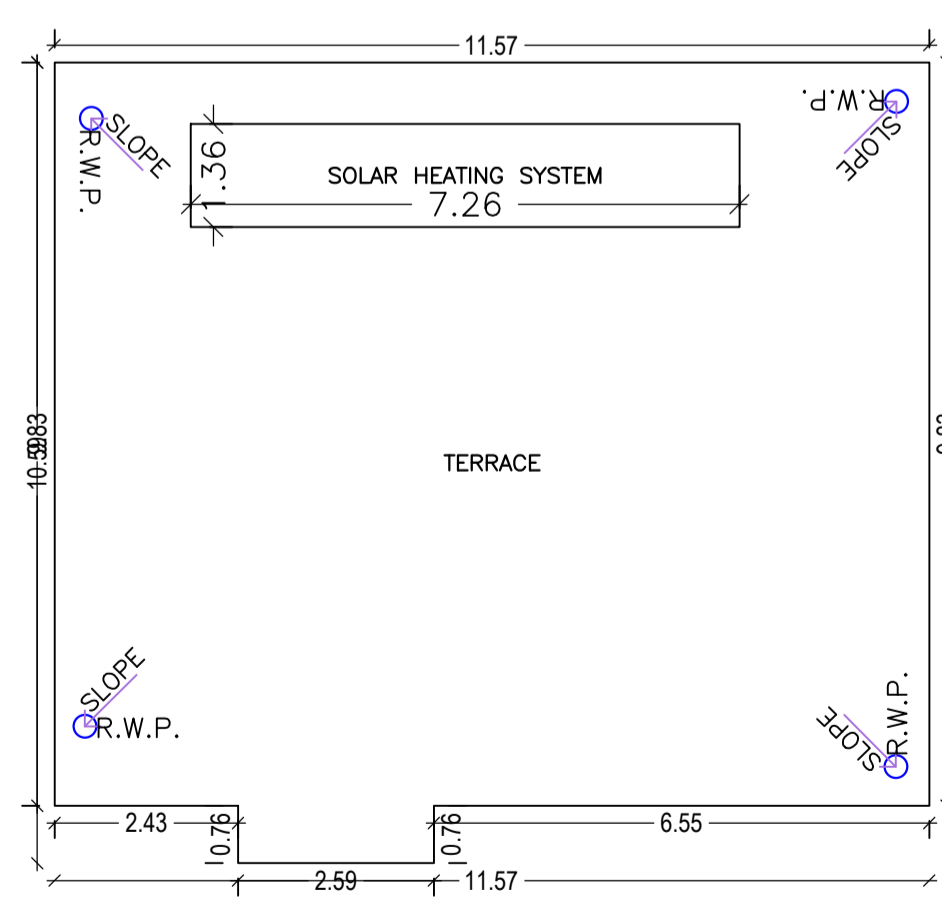

TERRACE FLOOR PLAN (SCALE 1:100)

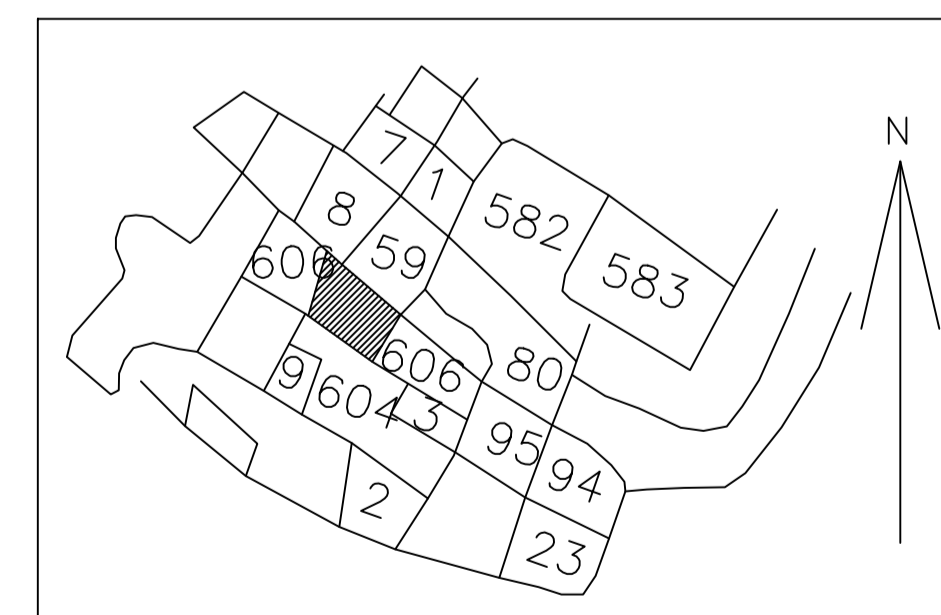

LTP NAME AND SIGNATURE	STRUCTURAL ENG'S NAME AND SIGNATURE	BUILDER NAME AND SIGNATURE	DIGITAL SIGNATURE
SANJEEV KUMAR RAY DMC/ENG/0001/2019			