

Project Title - PRIYANKA KUMARI

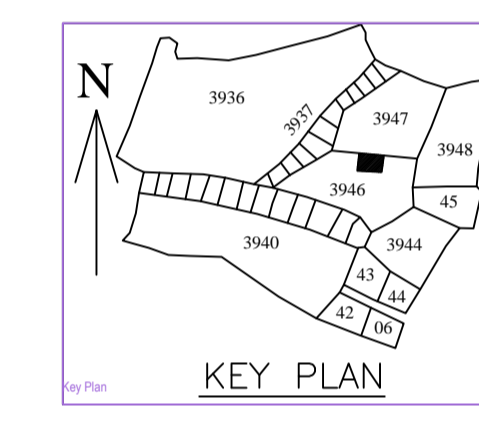
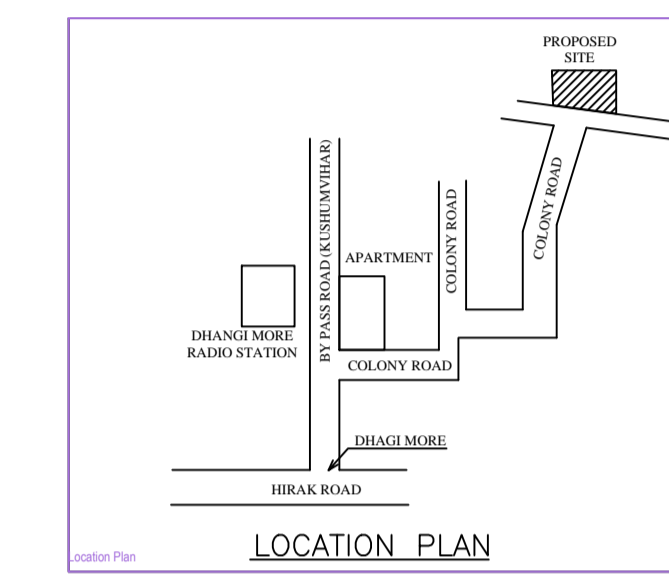
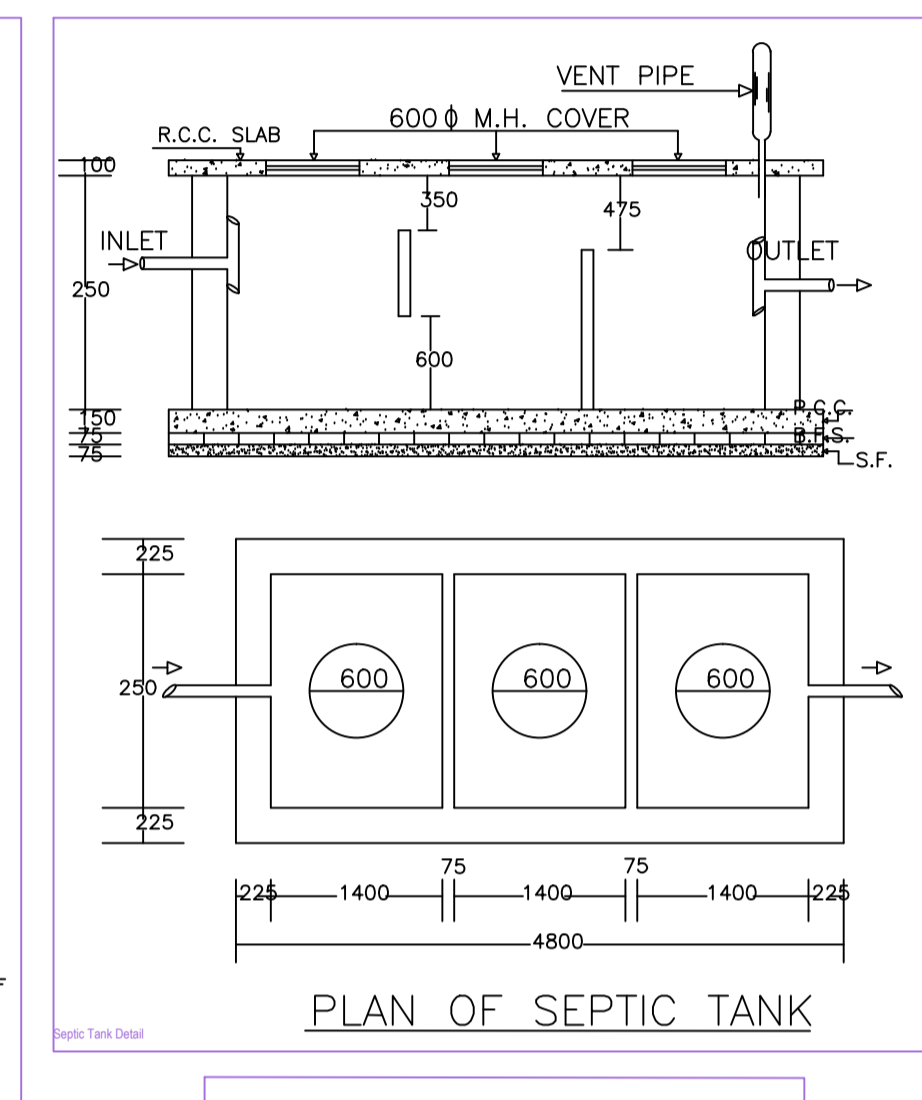
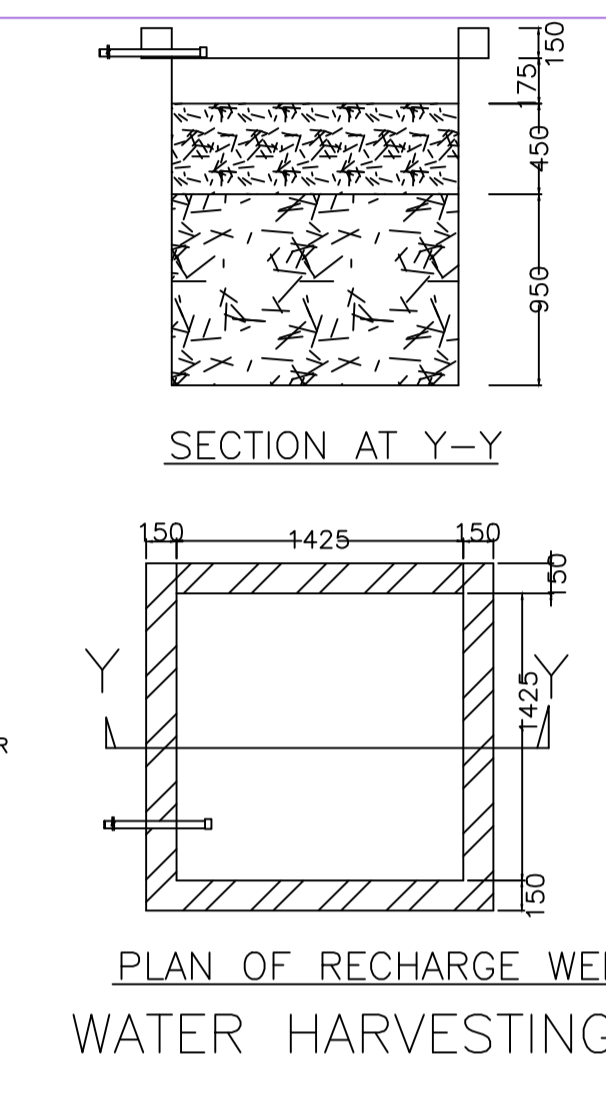
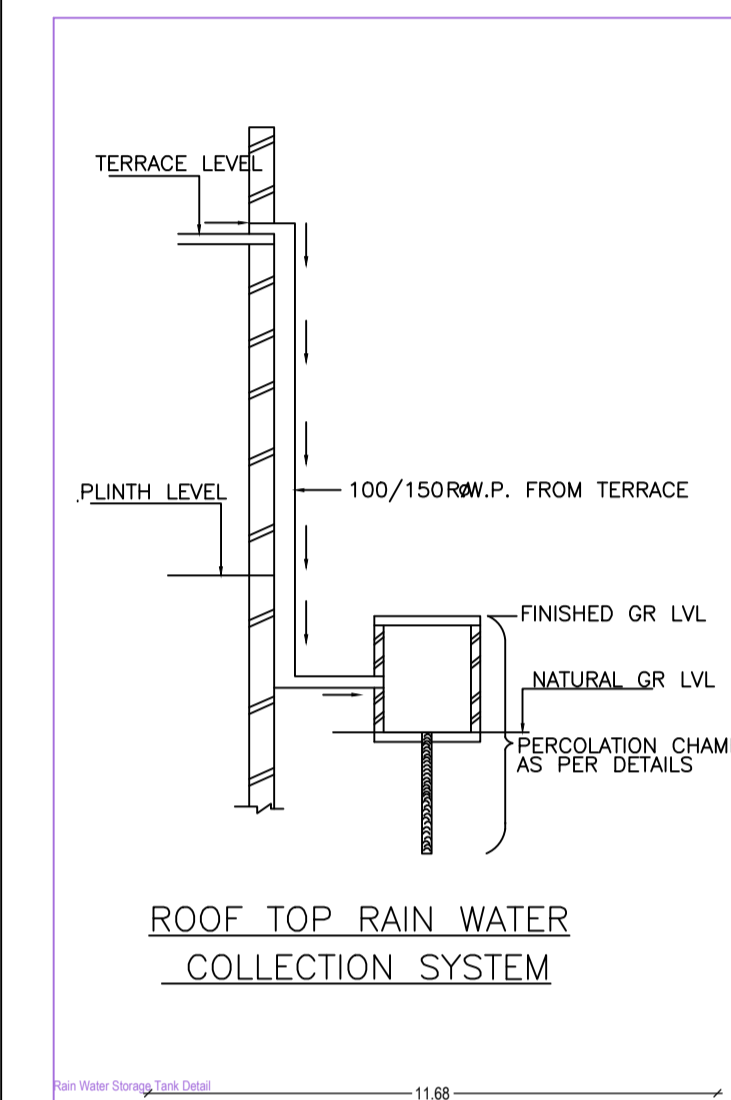
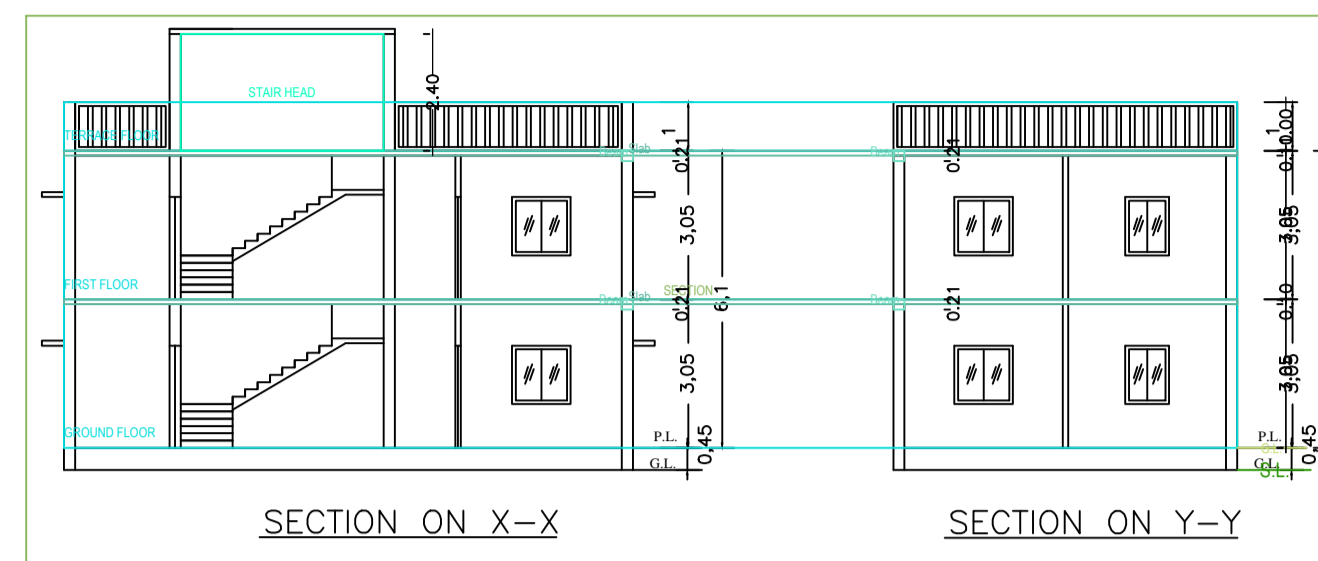
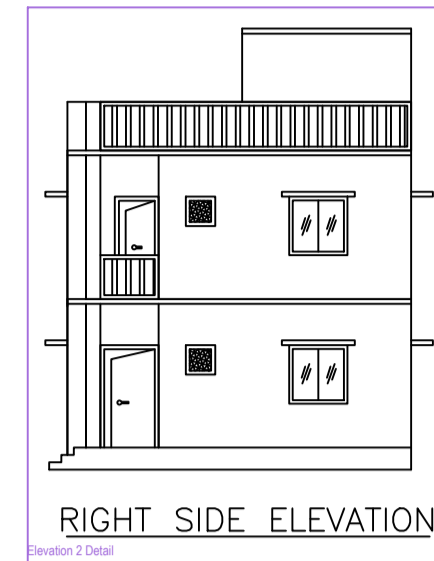
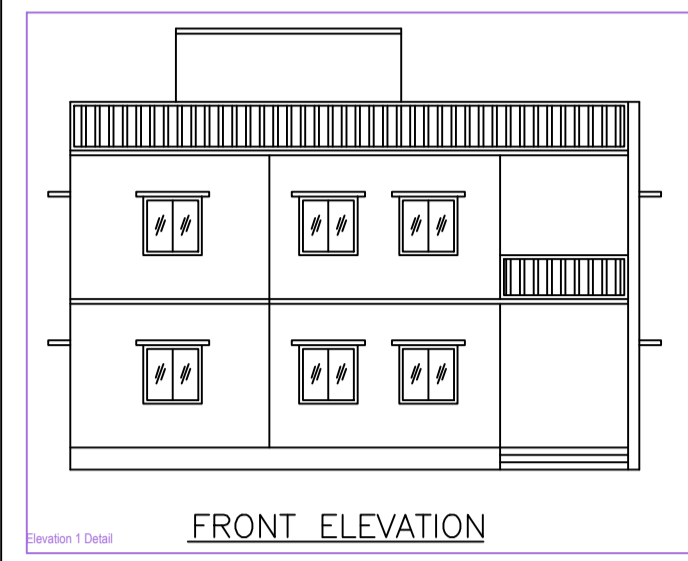

**BRIEF SPECIFICATION**

FOUNDATION----- CEMENT CONCRETE (1:1.5:3)  
 BRICK WORK IN FOUNDATION & SUPERSTRUCTURE  
 FIRST CLASS BRICK WORK IN CEMENT MORTAR (1:6)  
 D.P.C.-----25 D.P.C. IN CEMENT CONCRETE (1:2:4)  
 FLOOR-----25 I.P.S. OVER 75 P.C.C.  
 ROOF-----100 THK. R.C.C. ROOF (1:1.5:3)  
 LINTEL-----150 THK. R.C.C. LINTEL (1:1.5:3)  
 STAIRS-----RISE-- 150, TREAD-- 250

**DETAILS OF AREA**

TOTAL LAND AREA (AS PER DEED) ---	158.63 SQM.
TOTAL LAND AREA (AS PER SITE) ---	152.60 SQM.
GROUND FLOOR AREA-----	79.58 SQM.
FIRST FLOOR AREA-----	79.58 SQM.
TOTAL COVERED AREA-----	159.16 SQM.
% PLINTH AREA-----	52.14 %
FAR -----	1.04

**SCHEDULE**

D = 1.200X2.100	W = 1.200X1.200
D1 = 1.050X2.100	W1 = 0.900X1.200
D2 = 0.900X2.100	V = 0.600X0.600
D3 = 0.750X2.100	

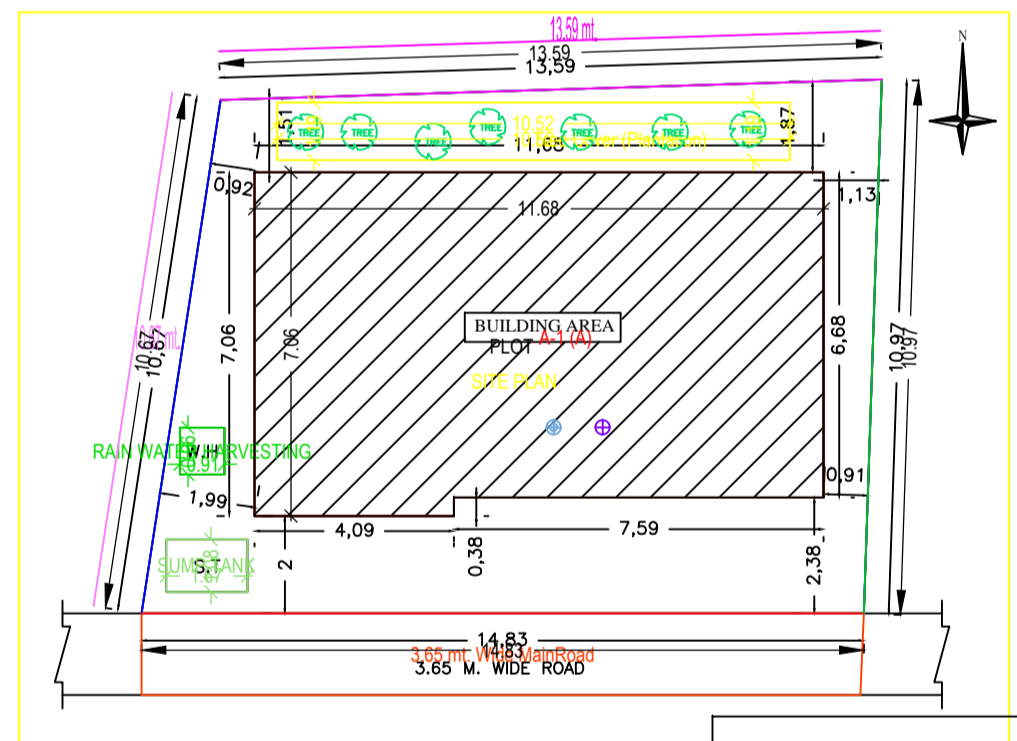
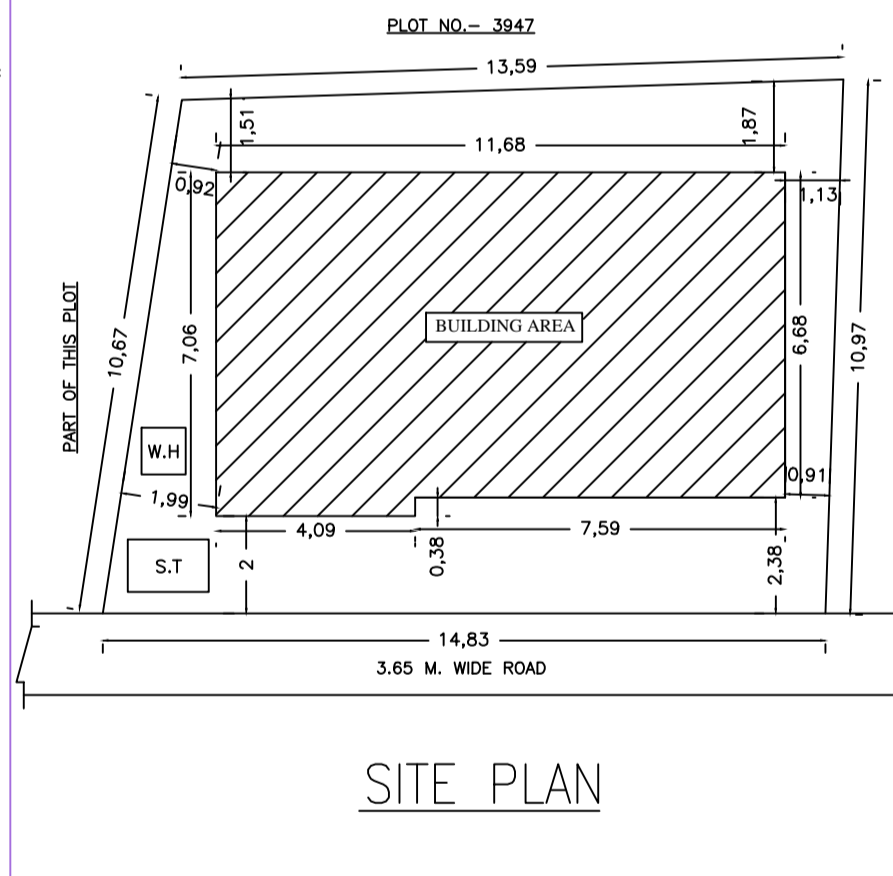
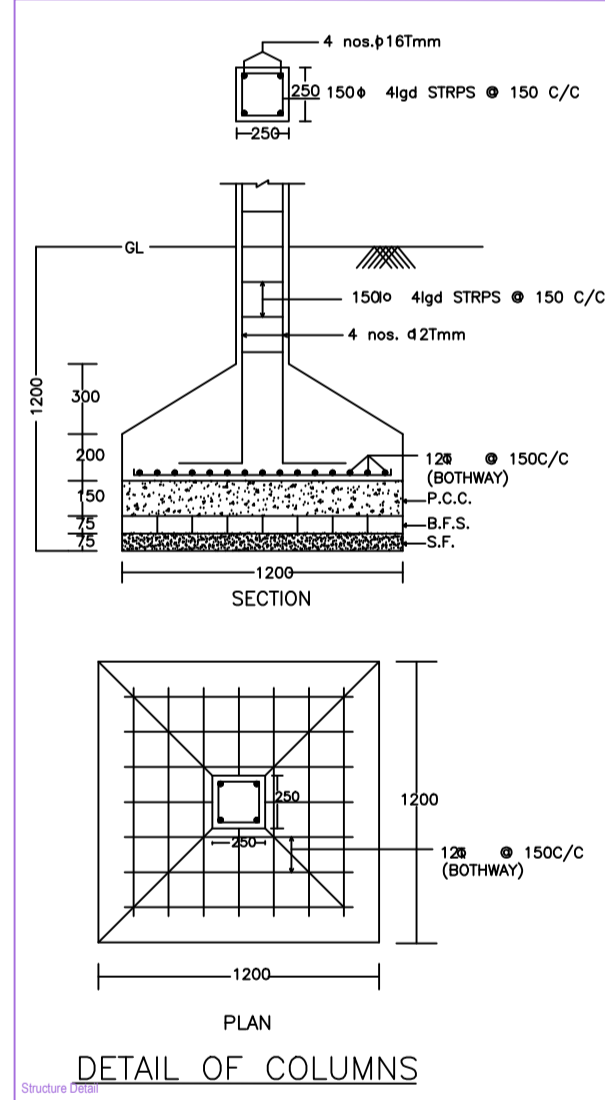
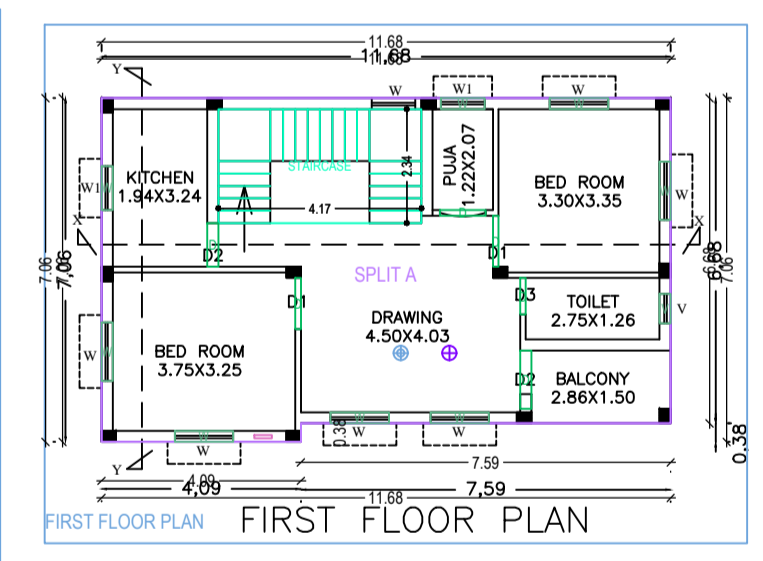
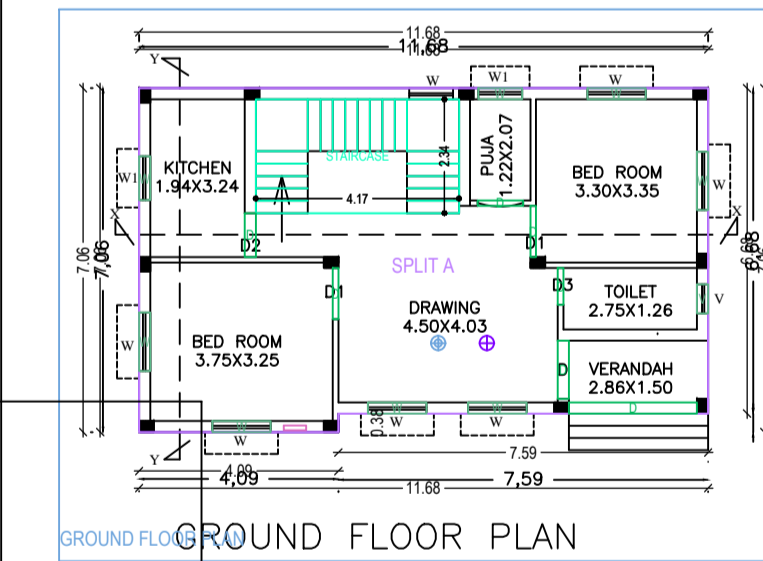
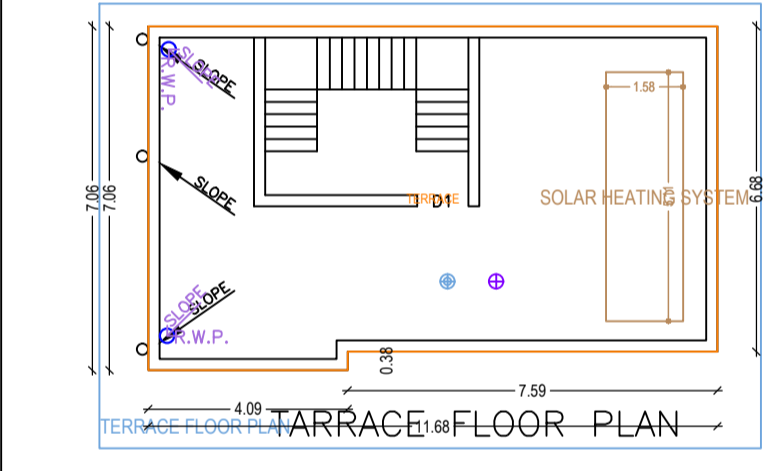

AREA STATEMENT DHANBAD MUNICIPAL CORPORATION

PROJECT DETAIL

Version No.	1.0
Version Date	16/10/2020
Plot Use	Residential
Plot Sub Use	Bungalow / Dwelling / Non Apartment
Land Use Zone	MS
Abutting Road Width	
Project Type	Building Permission
Nature of Development	New
Thana No.	
Plot No.	
Revenue Survey No./Survey No.	
Location	Old Area
Ward No.	
North	
South	
East	
West	

**AREA DETAILS**

AREA OF PLOT (Minimum)	(A)	152.60
Net Plot Area (Gross Plot Area - Deduction from Gross Plot Area)	(A-Deductions)	152.60
Deductions for Balance Plot Area from Gross Plot Area		
COP Area		12.49
Total		12.49
Balance Plot Area (Net Plot Area - Recreational/Amenity space)	(A-Deductions)	140.11
Plot Area for Coverage (Net Plot Area)	(A-Deductions)	152.60
Plot Area for FSI (Net Plot Area - Recreational/Amenity space)	(A-Deductions)	152.60
COVERAGE CHECK		
Proposed Coverage Area (52.15 %)		79.59
Net Coverage Area (52.15 %)		79.59
FAR CHECK		
Proposed Area of FAR		159.16
Total Area of FAR		159.16
BUILT UP AREA CHECK		
Total Proposed Built Up Area		159.16
ASCT/ENGT/SUPERVISOR (Regd)		OWNER
DEVELOPMENT AUTHORITY		LOCAL BODY

**COLOR INDEX**

PLT BOUNDARY	
ABUTTING ROAD	
PROPOSED WORK (COVERAGE AREA)	
EXISTING (To be retained)	
EXISTING (To be demolished)	

**Color Index**

MARGIN DETAIL:

Building / W/S	Road Name	Front Margin	Rear Margin	Side1 Margin	Side2 Margin
A/A	3.05 mt. W/S	2.00	1.51	0.92	0.91

**FAR & Tenement Details (Table 4c-1)**

Building	No. of Same Bldg	Total Built Up Area (Sq.mt.)	Proposed FAR Area (Sq.mt.)	Total FAR Area (Sq.mt.)	Tenn (No.)
A/A	1	159.16	159.16	159.16	01
Gross Total	1	159.16	159.16	159.16	01

**TITLE OF DRAWING**

PLAN OF PROPOSED RESIDENTIAL BUILDING OF SMT. PRIYANKA KUMARI, D/O. - DILEEP PRASAD, W/O. - SRI. ABHISHEK SHARMA, OF BADHAI TOLA PATNA CITY GULJARBAGH (BIHAR), UNDER MOUZA - KOLAKUSHMA, NO. - 12, (OLD) KHATA NO. - 81, (NEW) KHATA NO. - 330, (OLD) PLOT NO. - 3256, (NEW) PLOT NO. - 3946 IN THE DISTT. OF DHANBAD (JHARKHAND).

SIGNATURE OF OWNER

SIGNATURE OF ENGINEER

SCALE ALL DIMENSION ARE IN METRE

**Building - A (A)**

Floor Name	Total Built Up Area (Sq.mt.)	Proposed FAR Area (Sq.mt.)	Total FAR Area (Sq.mt.)	Tenn (No.)
Ground Floor	79.59	79.59	79.59	01
First Floor	79.59	79.59	79.59	01
Verandah Floor	0.00	0.00	0.00	00
Total	159.18	159.18	159.18	01
Total Number of Same Buildings	1			
Total	159.18	159.18	159.18	01

**SCHEDULE OF JOINERY:**

BUILDING NAME	NAME	LENGTH	HEIGHT	NO
A/A	D	2.10	2.10	02
A/A	D	0.90	2.10	02
A/A	D	0.90	2.10	02
A/A	D	1.55	2.10	04
A/A	D	1.20	2.10	02
A/A	D	2.63	2.10	01
Total				13

**SCHEDULE OF JOINERY:**

BUILDING NAME	NAME	LENGTH	HEIGHT	NO
A/A	V	0.60	1.50	02
A/A	W	0.90	1.20	04
A/A	W	1.20	1.20	12
Total				18

**UNIBUA Table for Building - A (A)**

FLOOR	Name	UNIBUA Type	UNIBUA Area	Carpet Area	No. of Rooms	No. of Tenement
GROUND FLOOR PLAN	SPLIT A	FLAT	159.18	159.11	7	1
Total			159.18	159.11	14	1