

Proposal Basic Information

Proposal File No.	DMC/BP/0372/W32/2021
Owner Name	SMT ANSHU KUMARI
Khata No	NEW - 641 , OLD - 18
Plot No	NEW - 1327 , OLD - 754
Village Name	Matkuria
Use	Residential
SubUse	Bungalow/ Dwelling / Non Apartment

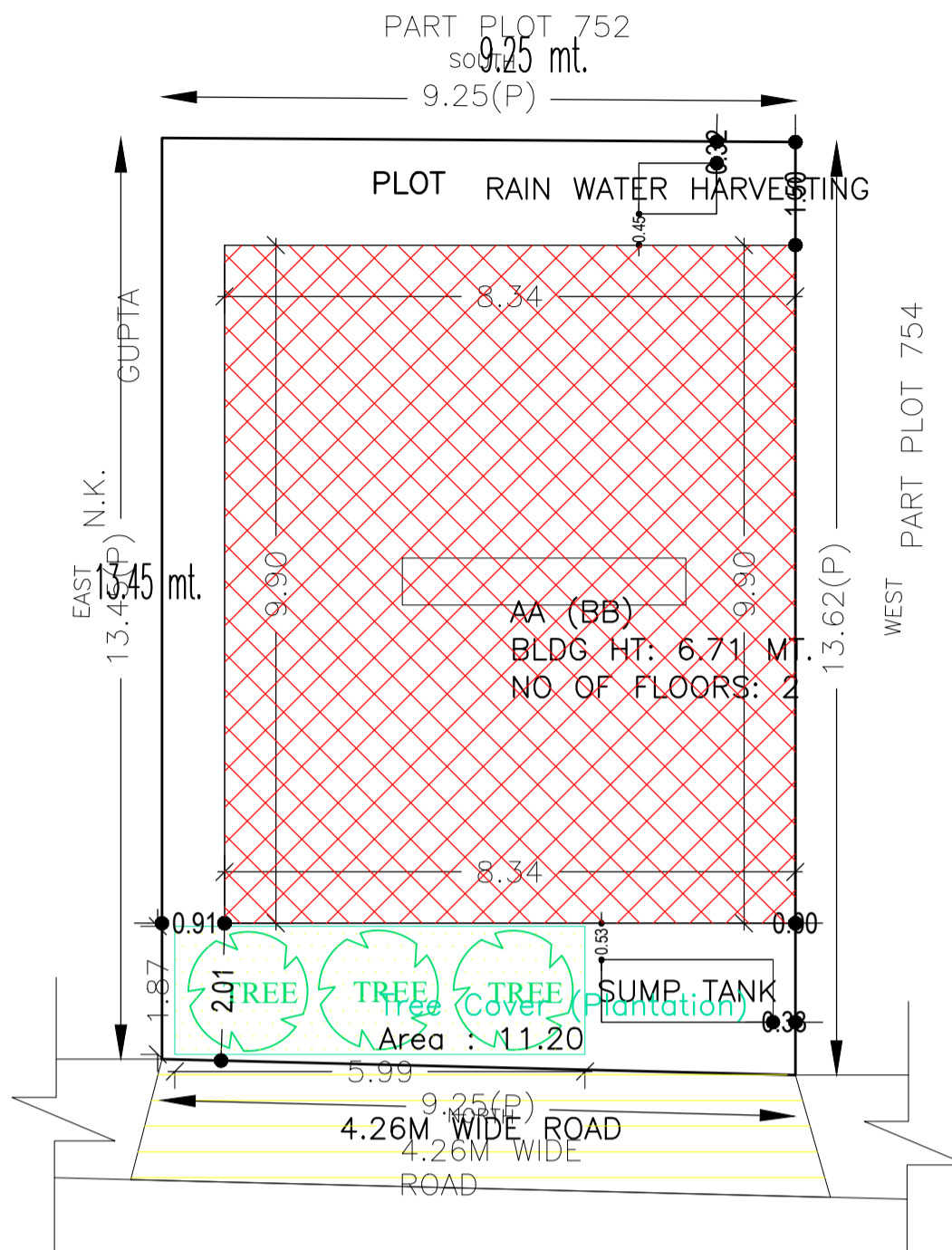

SITE PLAN

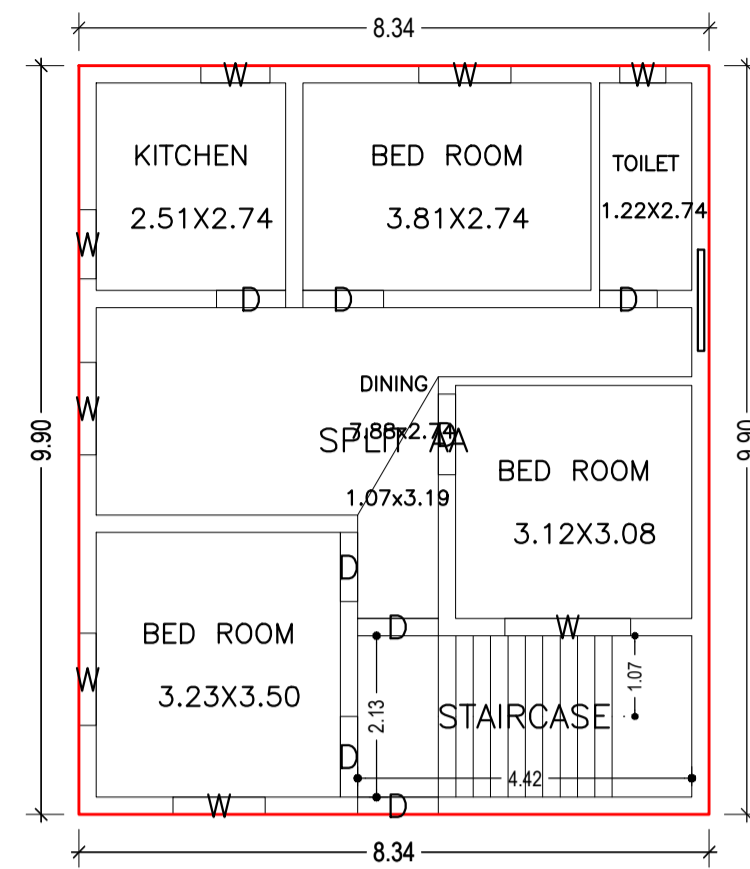

GROUND FLOOR PLAN (Proposed) (SCALE 1:100)

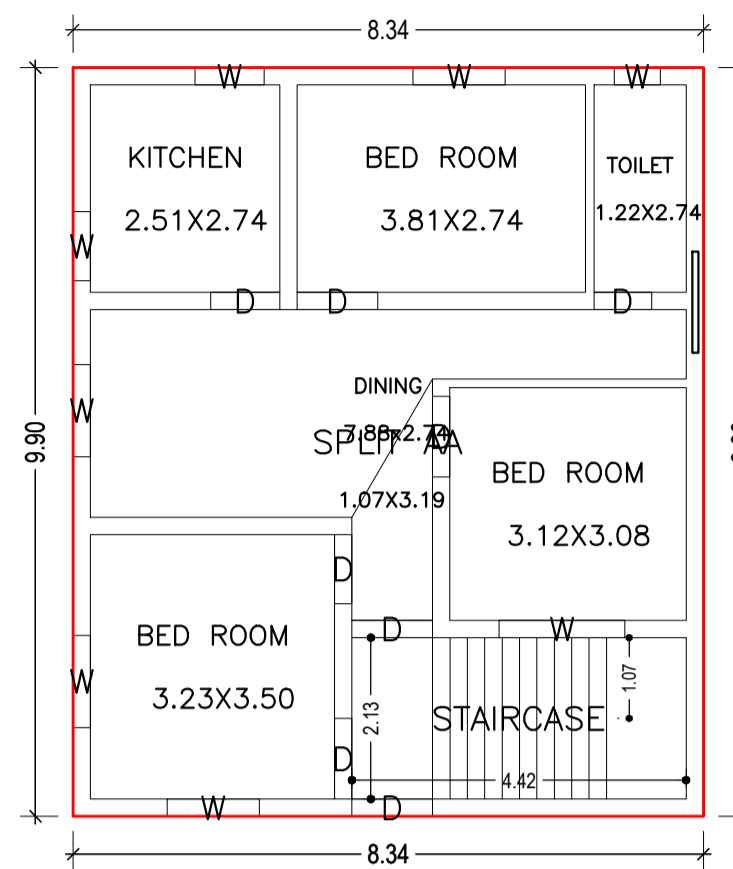

FIRST FLOOR PLAN (Proposed) (SCALE 1:100)

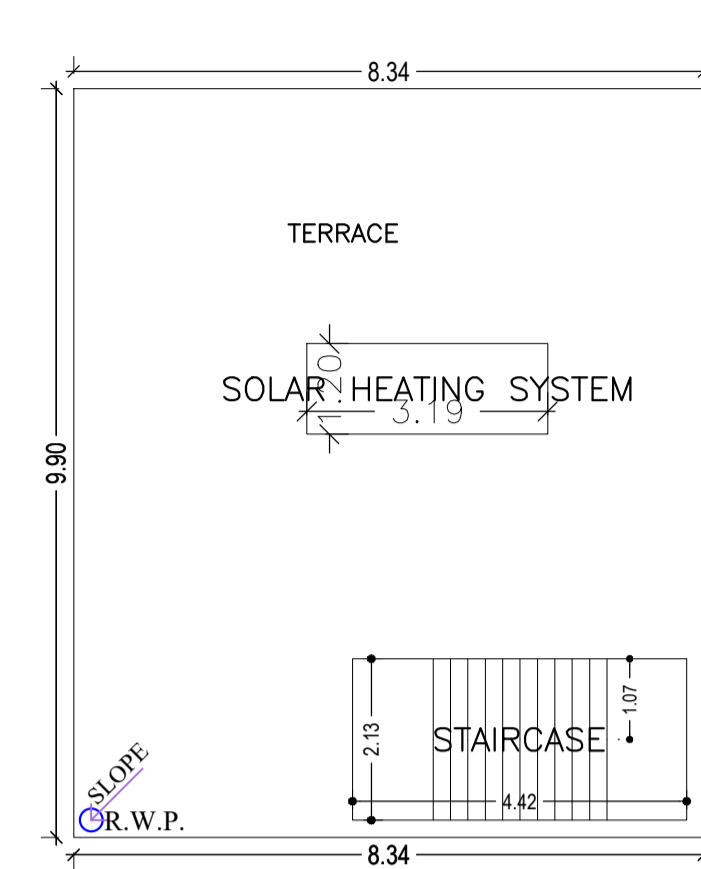

TERRACE FLOOR PLAN (SCALE 1:100)



KEY PLAN

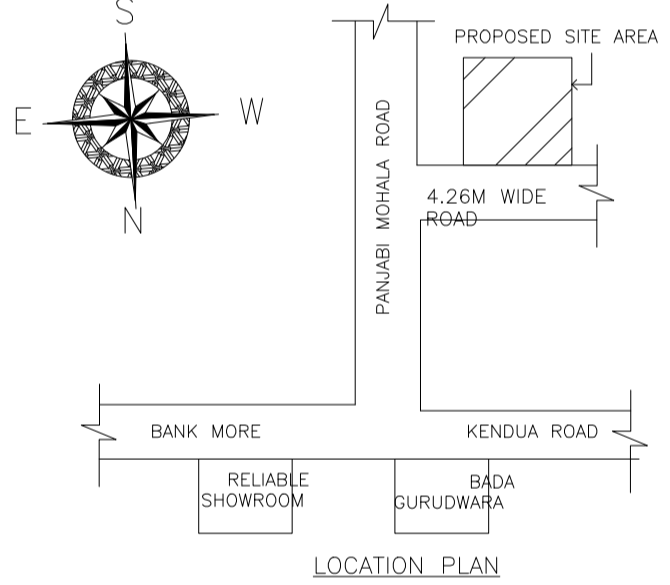
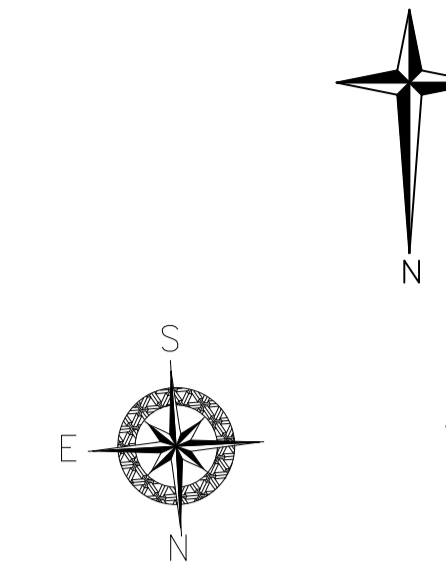

LOCATION PLAN

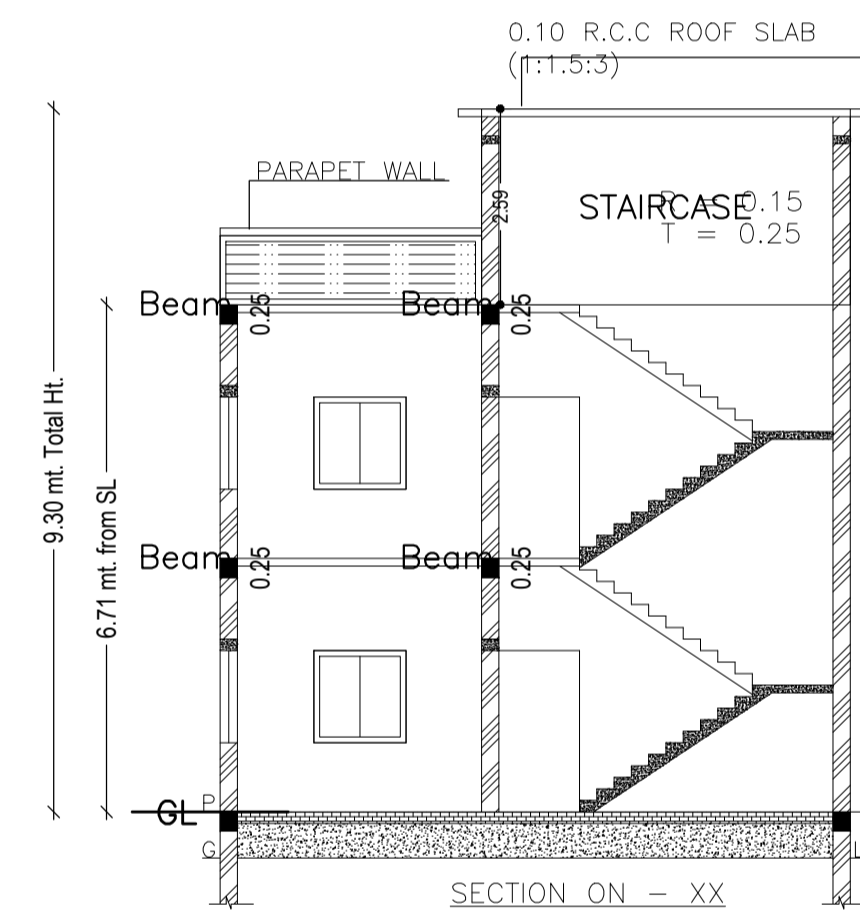

SECTION ON - XX

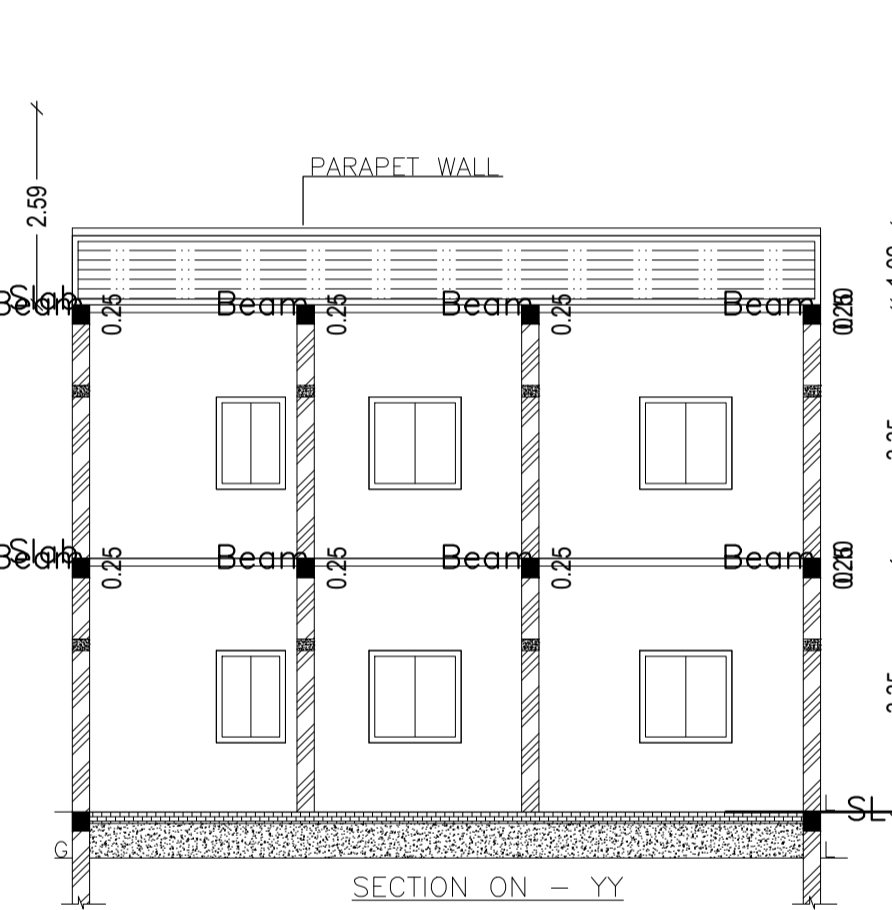

SECTION ON - YY

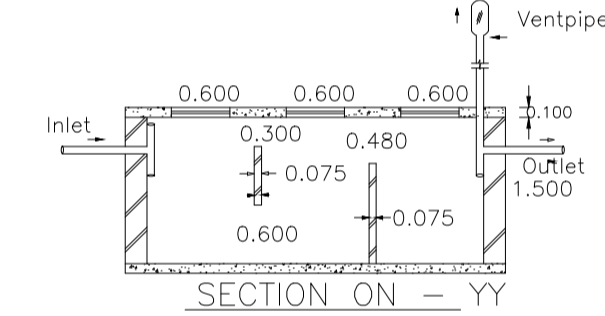

DETAILS OF SEPTIC TANK

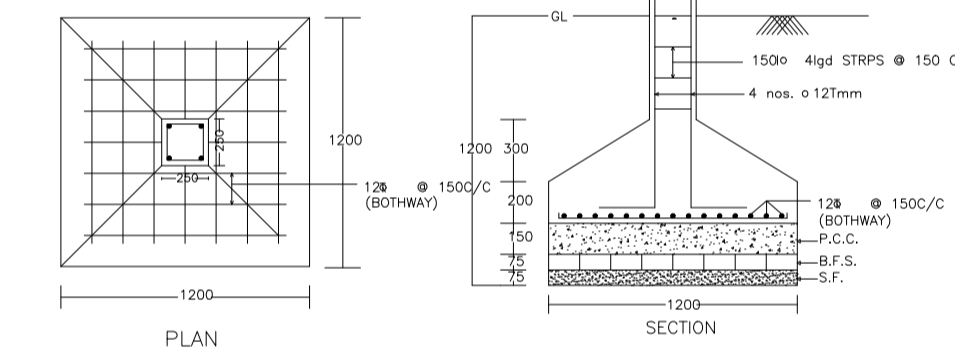

DETAIL OF COLUMNS

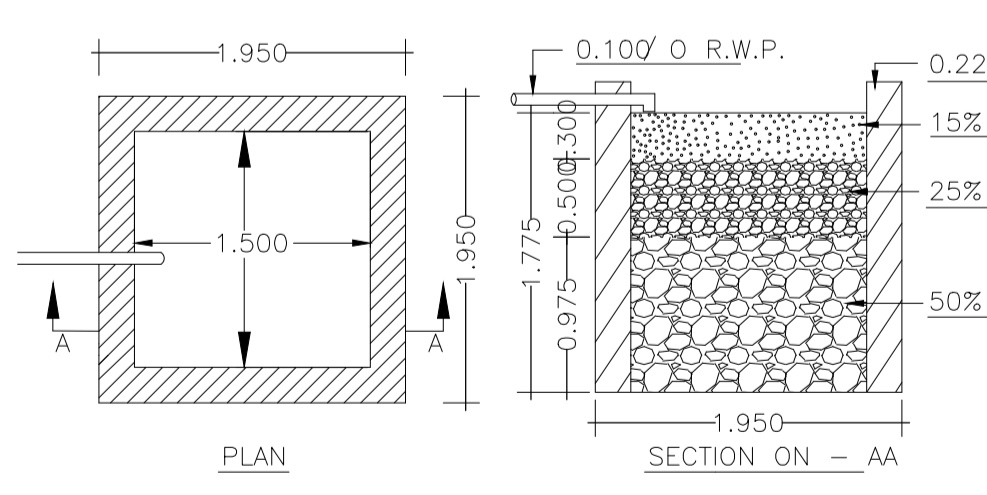

DETAILS OF WATER HARVESTING

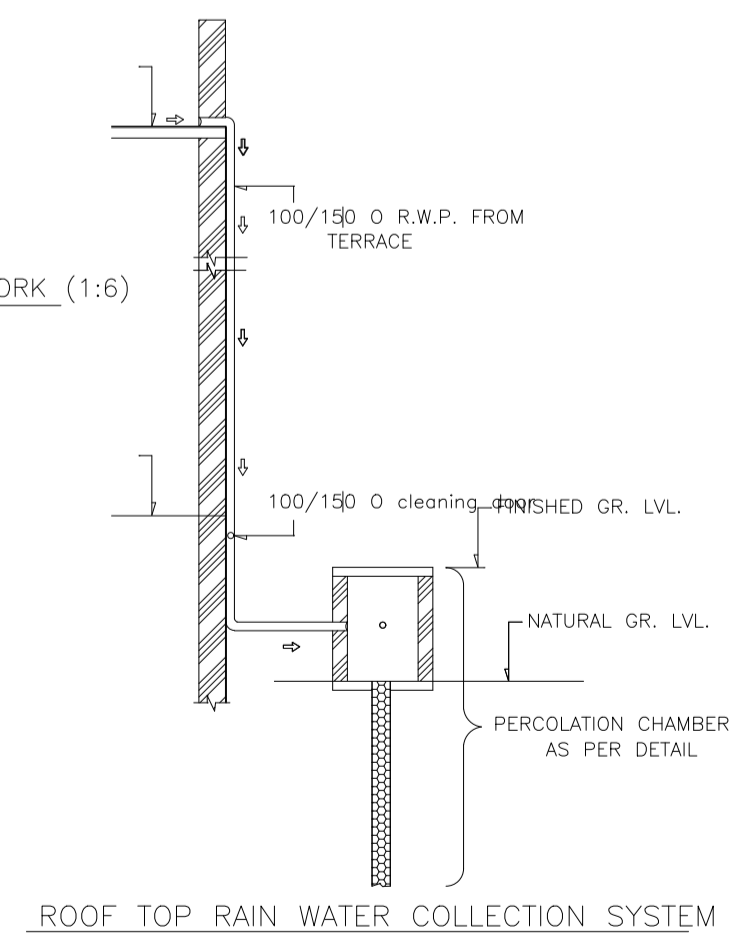

ROOF TOP RAIN WATER COLLECTION SYSTEM

Building :AA (BB)

Floor Name	Total Built Up Area (Sq.mt.)	Proposed FAR Area (Sq.mt.) Resi.	Total FAR Area (Sq.mt.)	Total Consumed Additional FAR Area (Sq.mt.)	Tnmt (No.)
Ground Floor	82.54	82.54	82.54	82.54	01
First Floor	82.54	82.54	82.54	82.54	00
Terrace Floor	0.00	0.00	0.00	0.00	00
Total :	165.08	165.08	165.08	165.08	01
Total Number of Same Buildings :	1				
Total :	165.08	165.08	165.08	165.08	01

SCHEDULE OF DOOR:

BUILDING NAME	NAME	LENGTH	HEIGHT	NOS
AA (BB)	D	0.76	2.10	02
AA (BB)	D	0.91	2.10	04
AA (BB)	D	1.07	2.10	08

SCHEDULE OF WINDOW/VENTILATION:

BUILDING NAME	NAME	LENGTH	HEIGHT	NOS
AA (BB)	W	0.61	1.20	02
AA (BB)	W	0.91	1.20	04
AA (BB)	W	1.22	1.20	08
AA (BB)	W	1.66	1.20	02

UnitBUA Table for Building :AA (BB)

FLOOR	Name	UnitBUA Type	UnitBUA Area	Carpet Area	No. of Rooms	No. of Tenement
GROUND FLOOR PLAN	SPLIT AA	FLAT	165.08	164.85	6	1
FIRST FLOOR PLAN	SPLIT AA	FLAT	0.00	0.00	6	0
Total:	-	-	165.08	164.85	12	1

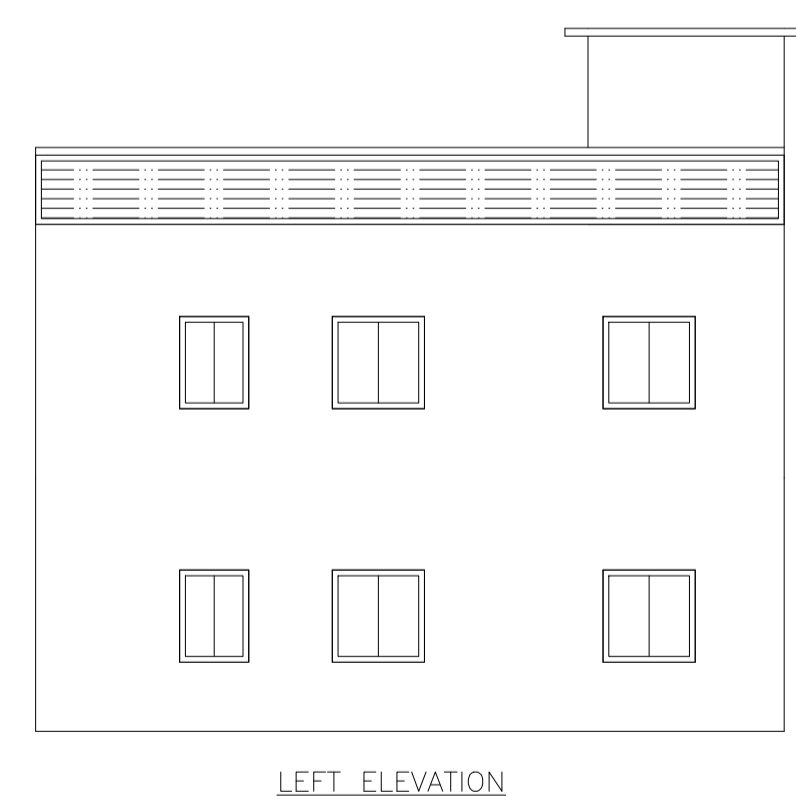

LEFT ELEVATION

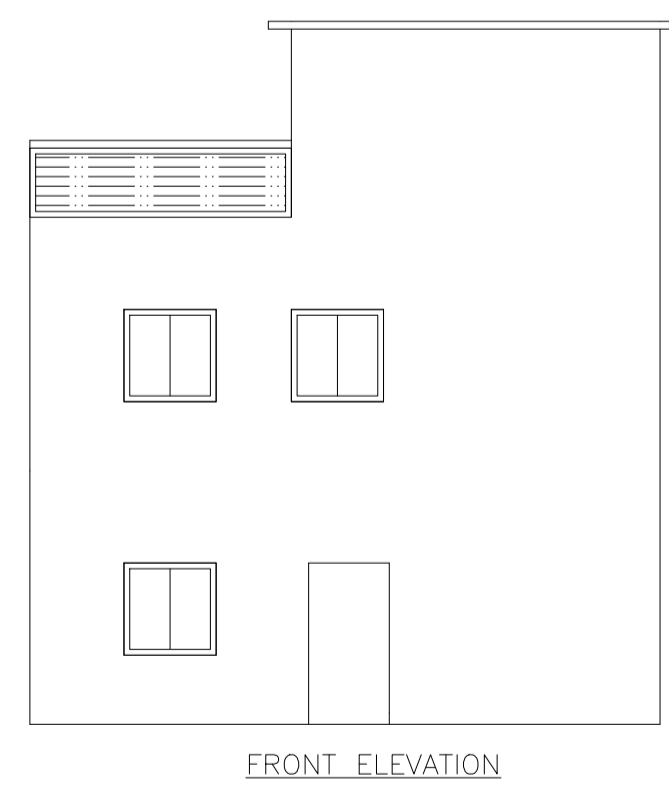

FRONT ELEVATION

AREA STATEMENT		VERSION NO. : 1.0.61
DHANBAD MUNICIPAL CORPORATION		VERSION DATE: 16/10/2020
PROJECT DETAIL:		
Region: JHARKHAND URBAN LOCAL BODIES	Plot Use: Residential	
District: DHANBAD	Plot SubUse: Bungalow/ Dwelling / Non Apartment	
Authority: DHANBAD MUNICIPAL CORPORATION	PlotNearbyReligiousStructure: NA	
Inward No: DMC/BP/0372/W32/2021	Plot/SubPlot No: NEW - 1327 OLD - 754	
Application Type: General Proposal	North: Road Width - 3.65M WIDE ROAD	
Project Type: Building Permission	South: Plot No. - PART PLOT 752	
Nature of Development: New	East: Plot No. - N.K. GUPTA	
Location of Development Area: Old Area	West: Plot No. - PART PLOT 754	
AREA DETAILS:		
AREA OF PLOT (Minimum)	(A)	SQ.MT. 125.24
NET AREA OF PLOT(Gross Plot Area - Deduction from Gross Plot area)	(A-Deductions)	125.24
Deduction for Balance Plot Area(from Gross Plot Area)		
Common Plot		11.20
Total		11.20
BALANCE AREA OF PLOT(Net Plot Area - Recreational/Amenity space)	(A-Deductions)	114.03
PLOT AREA FOR COVERAGE(Net Plot Area)	(A-Deductions)	125.24
Plot Area for FAR (Net Plot Area + RoadWidening Area)	(A-Deductions)	125.24
COVERAGE CHECK		
Permissible Coverage area ( 70.00 % )		87.67
Proposed Coverage Area ( 65.91 % )		82.54
Total Prop. Coverage Area ( 65.91 % )		82.54
Balance coverage area ( 4.10 % )		5.13
FAR CHECK		
Perm. FAR Area ( 1.50 )		187.86
Total Perm. FAR area		187.86
Residential FAR		165.08
Proposed FAR Area		165.08
Total Proposed FAR Area		165.08
Consumed FAR (Factor)		1.32
Balance FAR Area		22.78
BUILT UP AREA CHECK		
Total Proposed BuiltUp Area		165.08
ARCHITECT (Regd)		
ENGINEER (Regd)		UMESH CHANDRA SINGH
SUPERVISOR (Regd)		
OWNER (Regd)		SMT ANSHU KUMARI
DEVELOPMENT AUTHORITY		LOCAL BODY

COLOR INDEX

PLOT BOUNDARY	Black
ABUTTING ROAD	Red
PROPOSED CONSTRUCTION	Green
COMMON PLOT	Yellow
ROAD WIDENING AREA	Blue
EXISTING (To be retained)	Orange
EXISTING (To be demolished)	Grey

Buildingwise Floor FAR Details

Floor Name	Building Name AA (BB)		Total	
	Proposed Built Up Area (Sq.mt.)	Proposed FAR Area (Sq.mt.)	Total Proposed Built Up Area (Sq.mt.)	Total FAR Area (Sq.mt.)
Ground Floor	82.54	82.54	82.54	82.54
First Floor	82.54	82.54	82.54	82.54
Terrace Floor	0.00	0.00	0.00	0.00
Total :	165.08	165.08	165.08	165.08

Building USE/SUBUSE Details

Building Name	Building Use	Building SubUse	Building Structure
AA (BB)	Residential	Bungalow/ Dwelling / Non Apartment	Non-Highrise

FAR & Tenement Details (Table 4c-1)

Building	No. of Same Bldg	Total Built Up Area (Sq.mt.)	Proposed FAR Area (Sq.mt.) Resi.	Total FAR Area (Sq.mt.)	Total Consumed Additional FAR Area (Sq.mt.)	Tnmt (No.)
AA (BB)	1	165.08	165.08	165.08	165.08	01
Grand Total :	1	165.08	165.08	165.08	165.08	01

LTP NAME AND SIGNATURE	STRUCTURAL ENG'S NAME AND SIGNATURE	BUILDER NAME AND SIGNATURE	DIGITAL SIGNATURE
UMESH CHANDRA SINGH DMC/DFTM/001/2017			