

Project Title - SMT. JAYMNTI DEVI

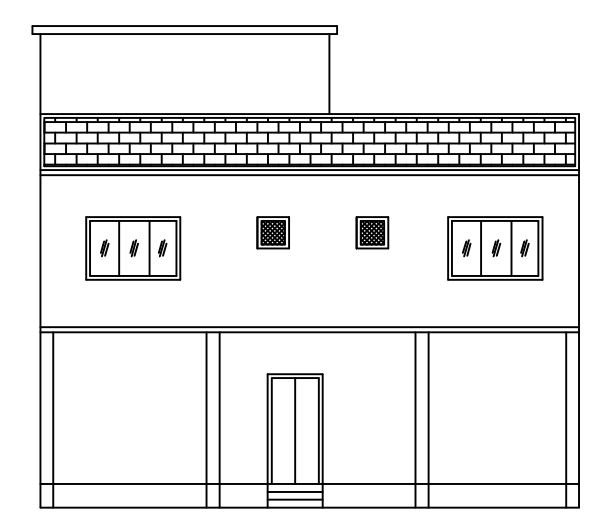

FRONT ELEVATION

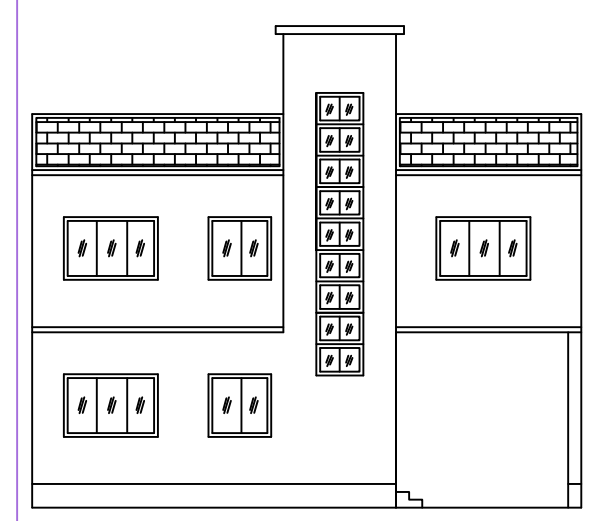

LEFT SIDE ELEVATION

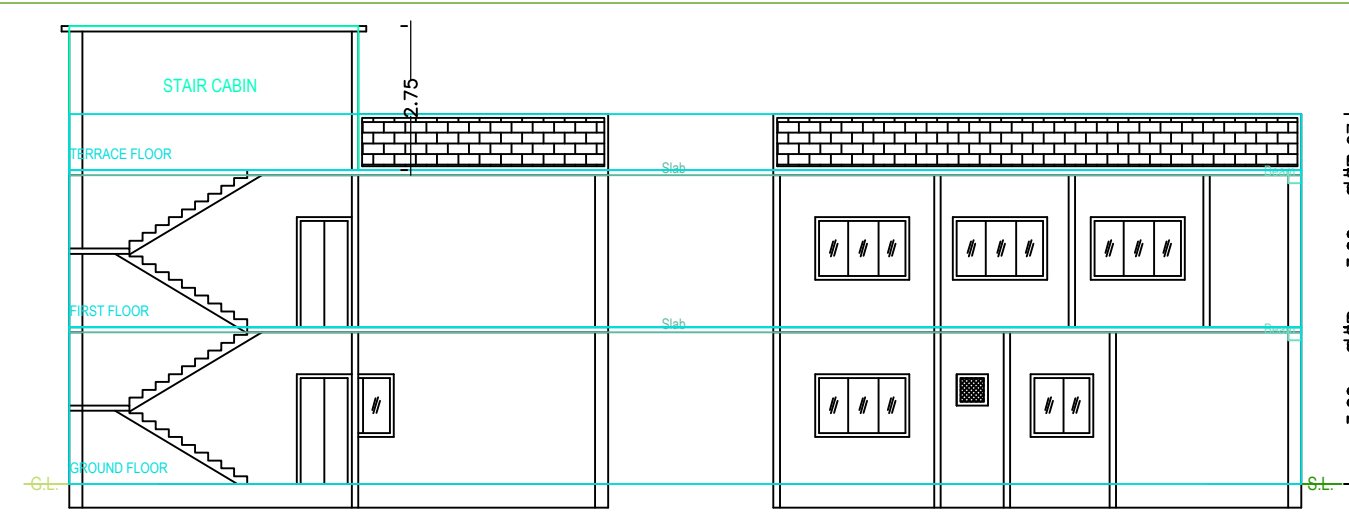

SECTION ON X-X

SECTION ON Y-Y

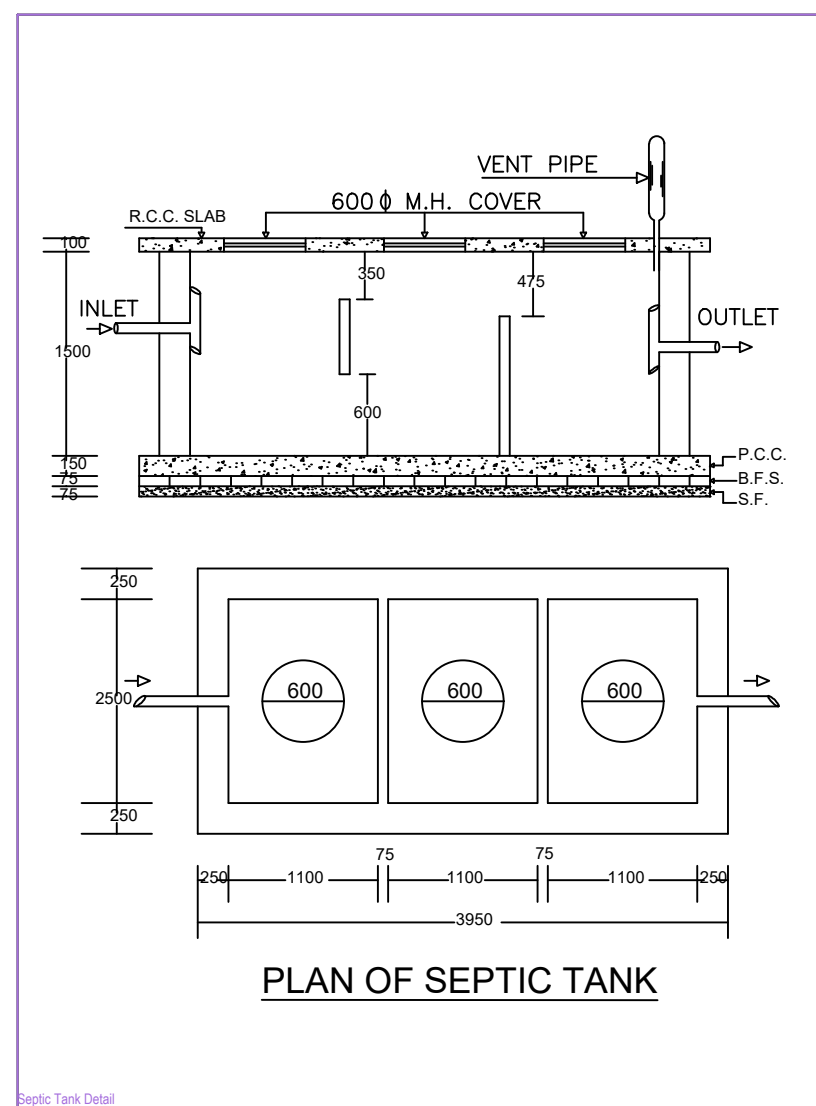
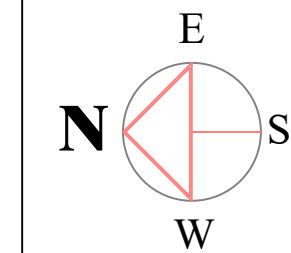

PLAN OF SEPTIC TANK

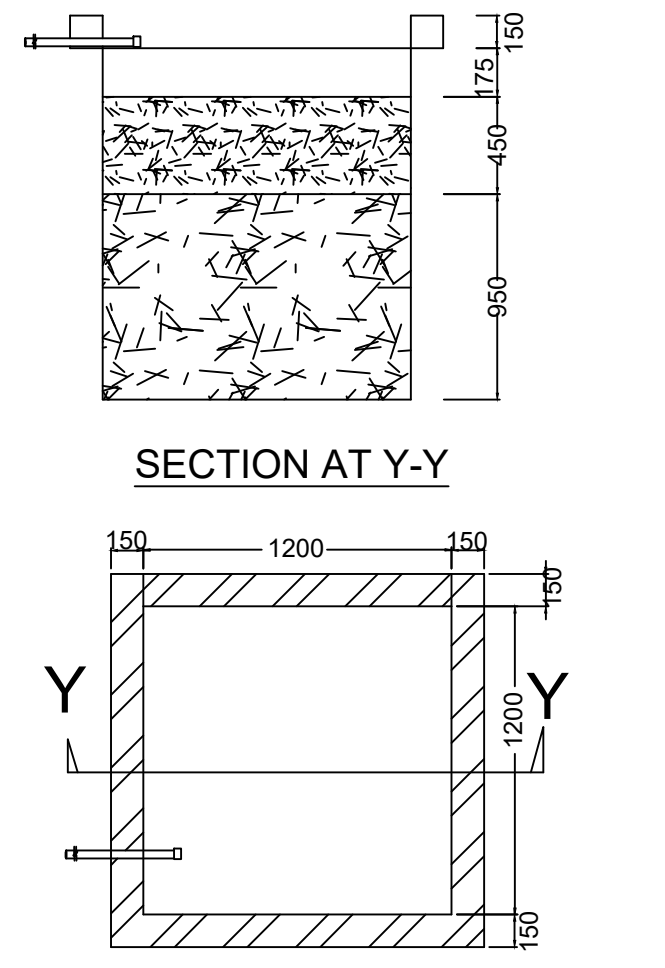

SECTION AT Y-Y

PLAN OF RECHARGE WELL

WATER HARVESTING

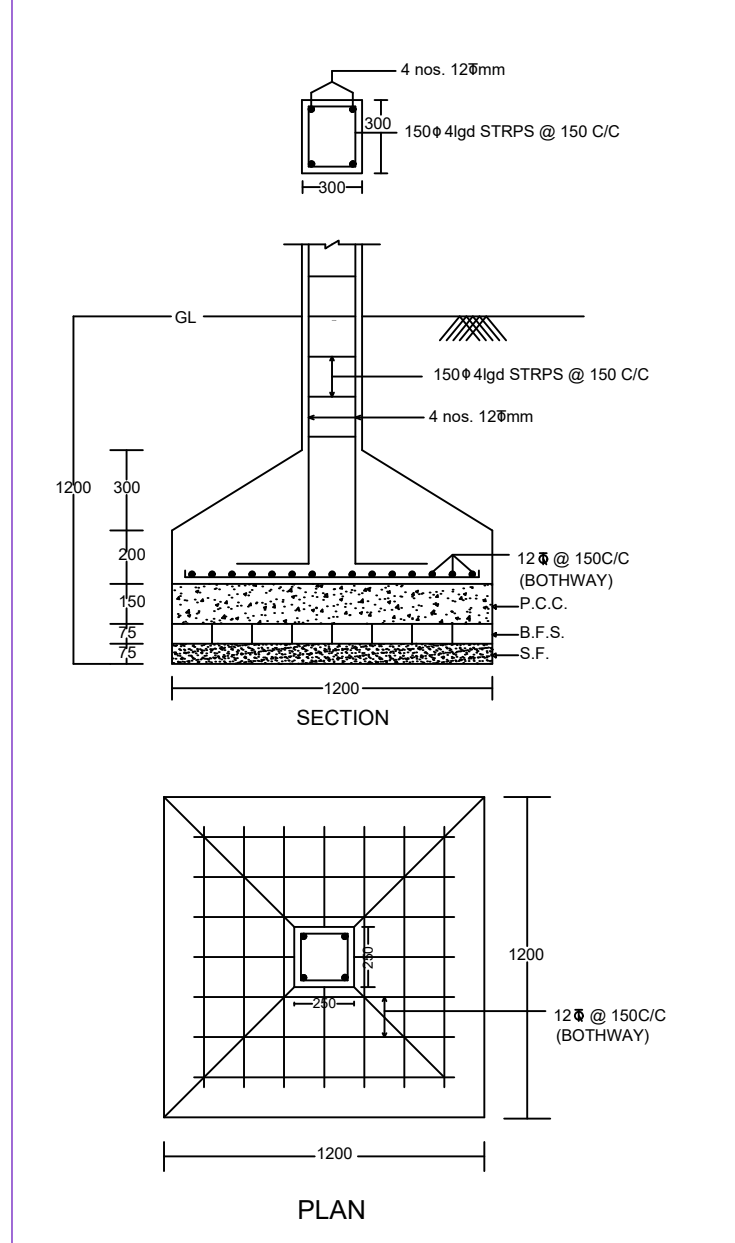

DETAIL OF COLUMNS

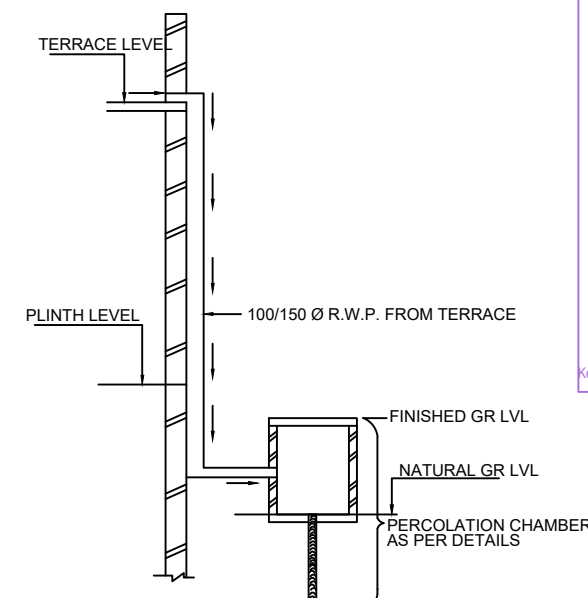

ROOF TOP RAIN WATER COLLECTION SYSTEM

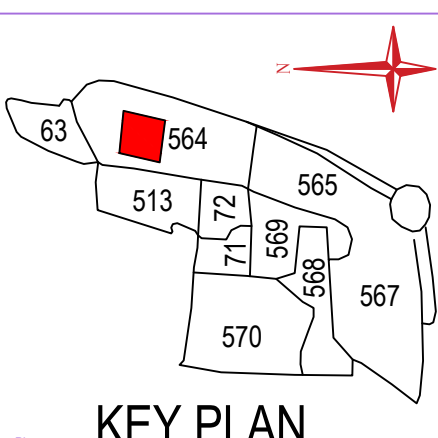

KEY PLAN

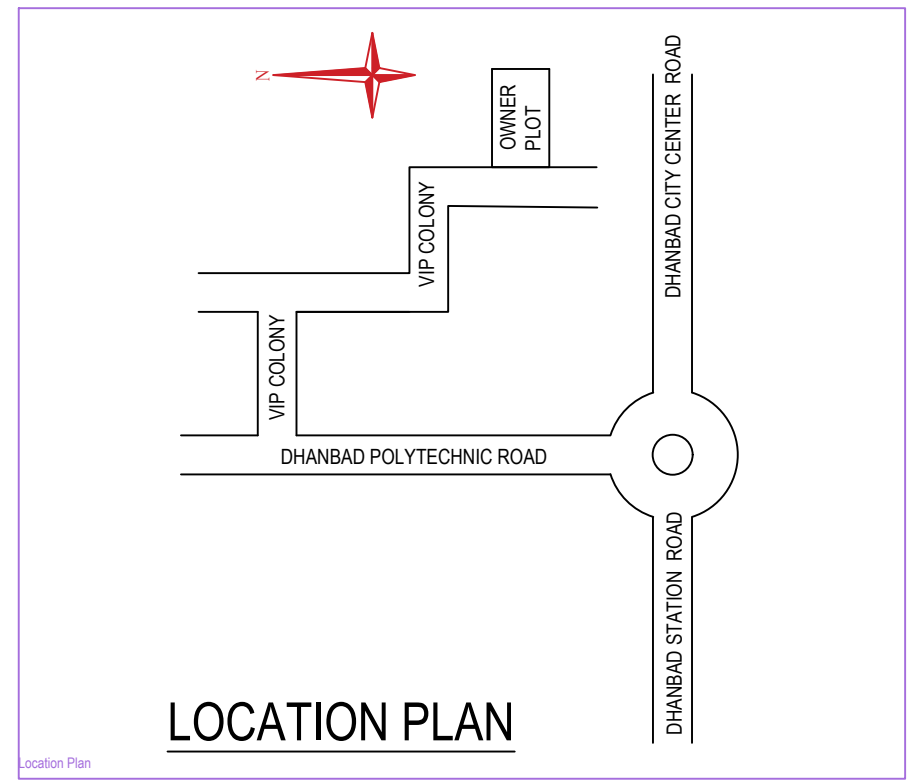

LOCATION PLAN

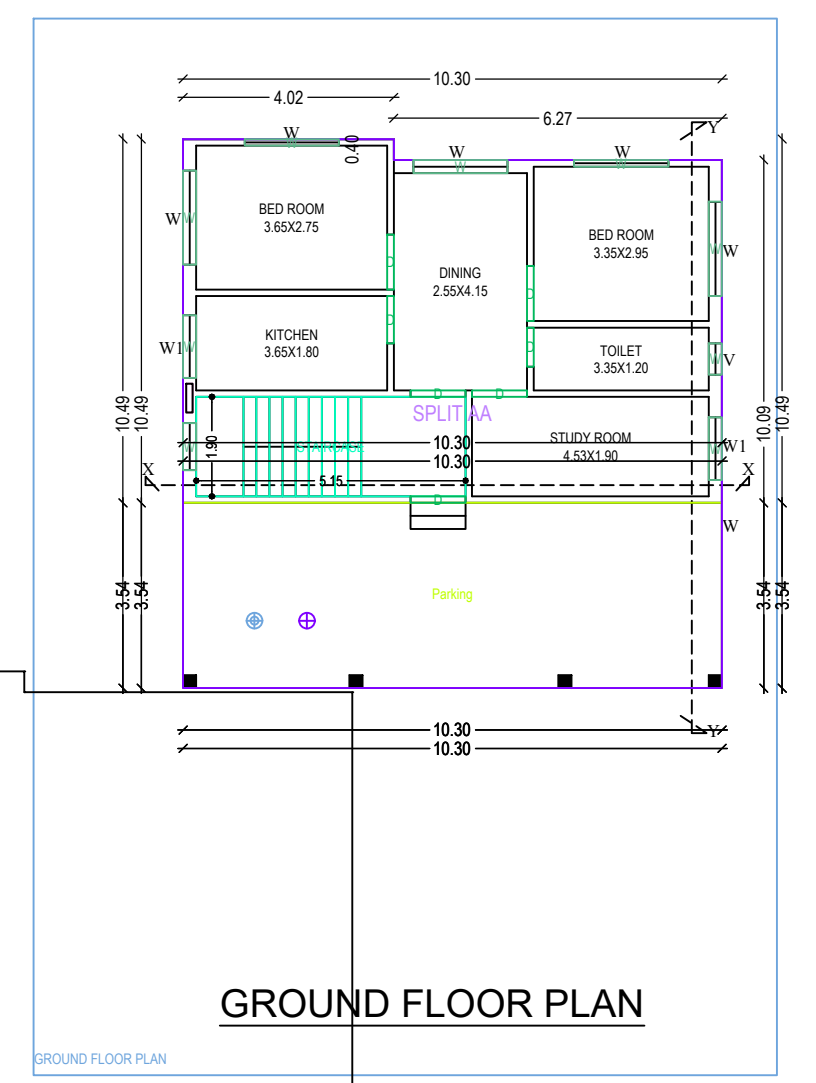

GROUND FLOOR PLAN

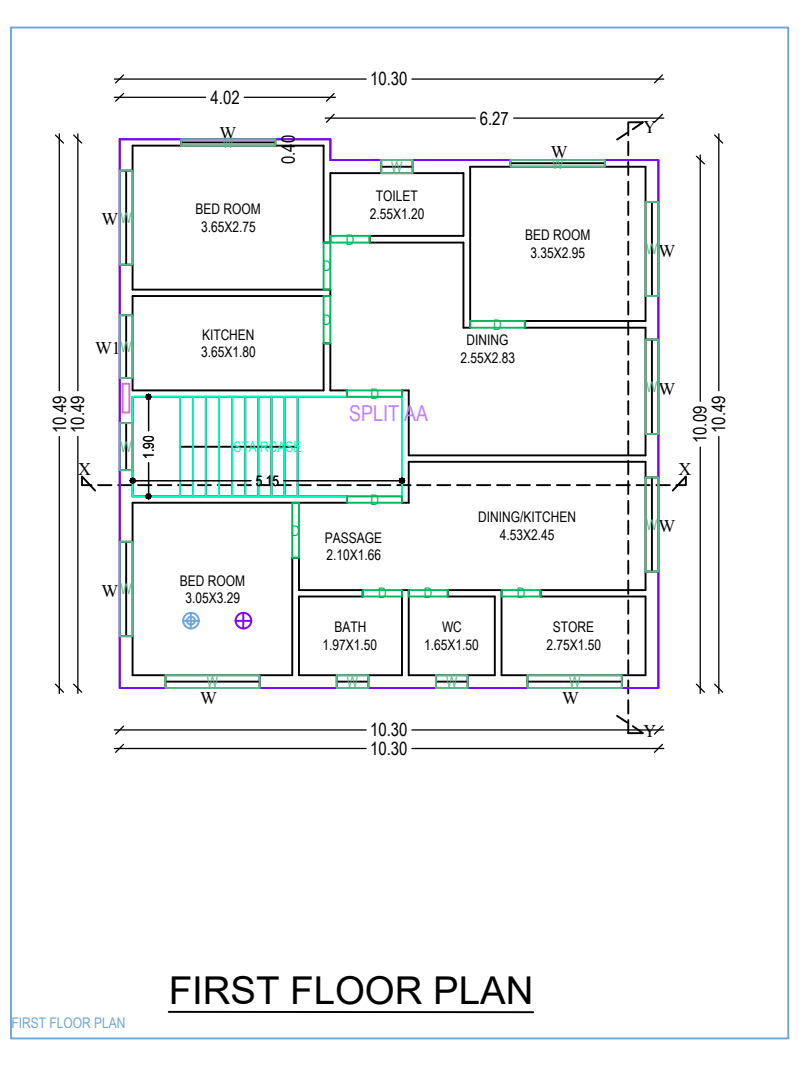

FIRST FLOOR PLAN

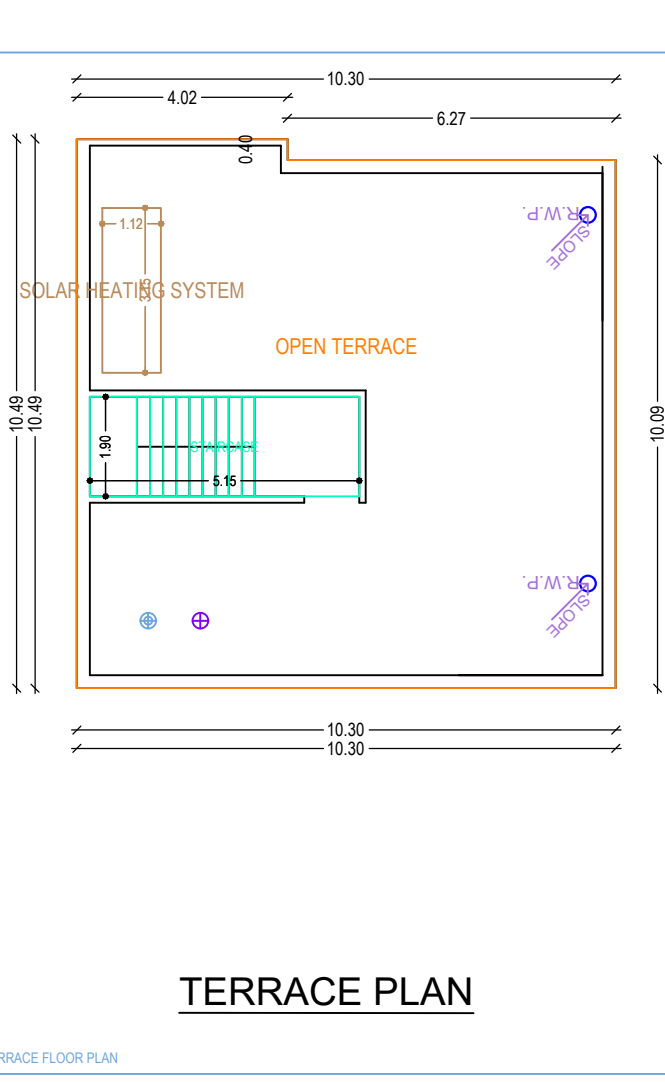

TERRACE PLAN

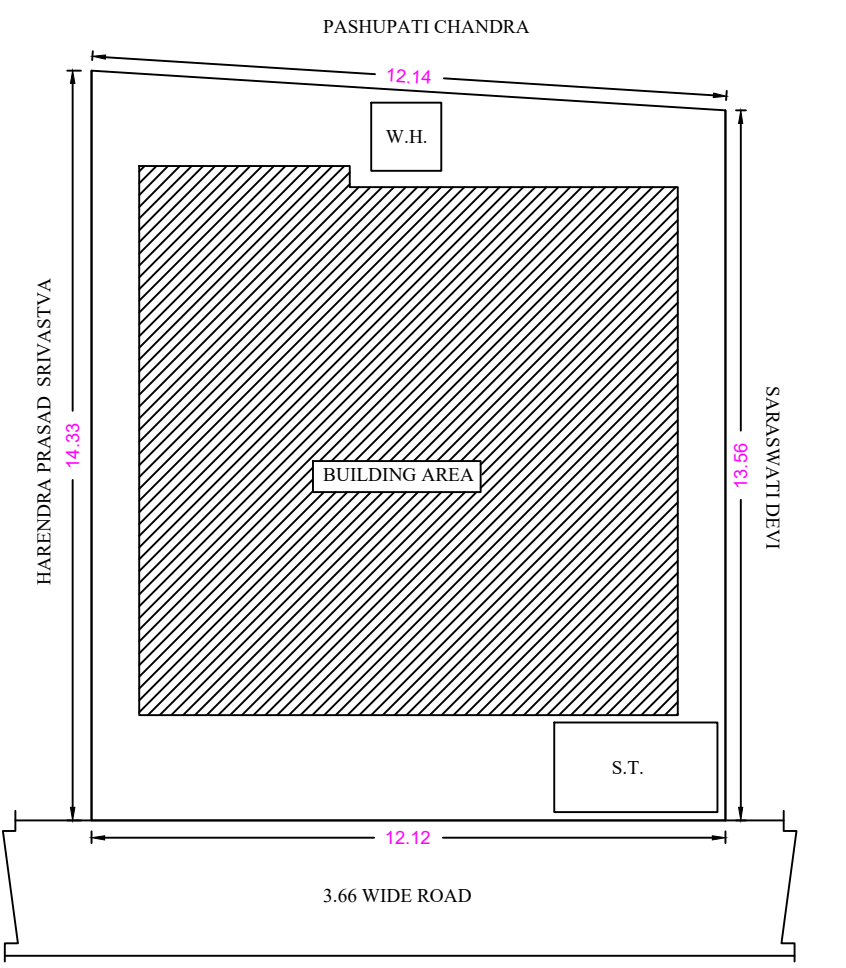

SITE PLAN

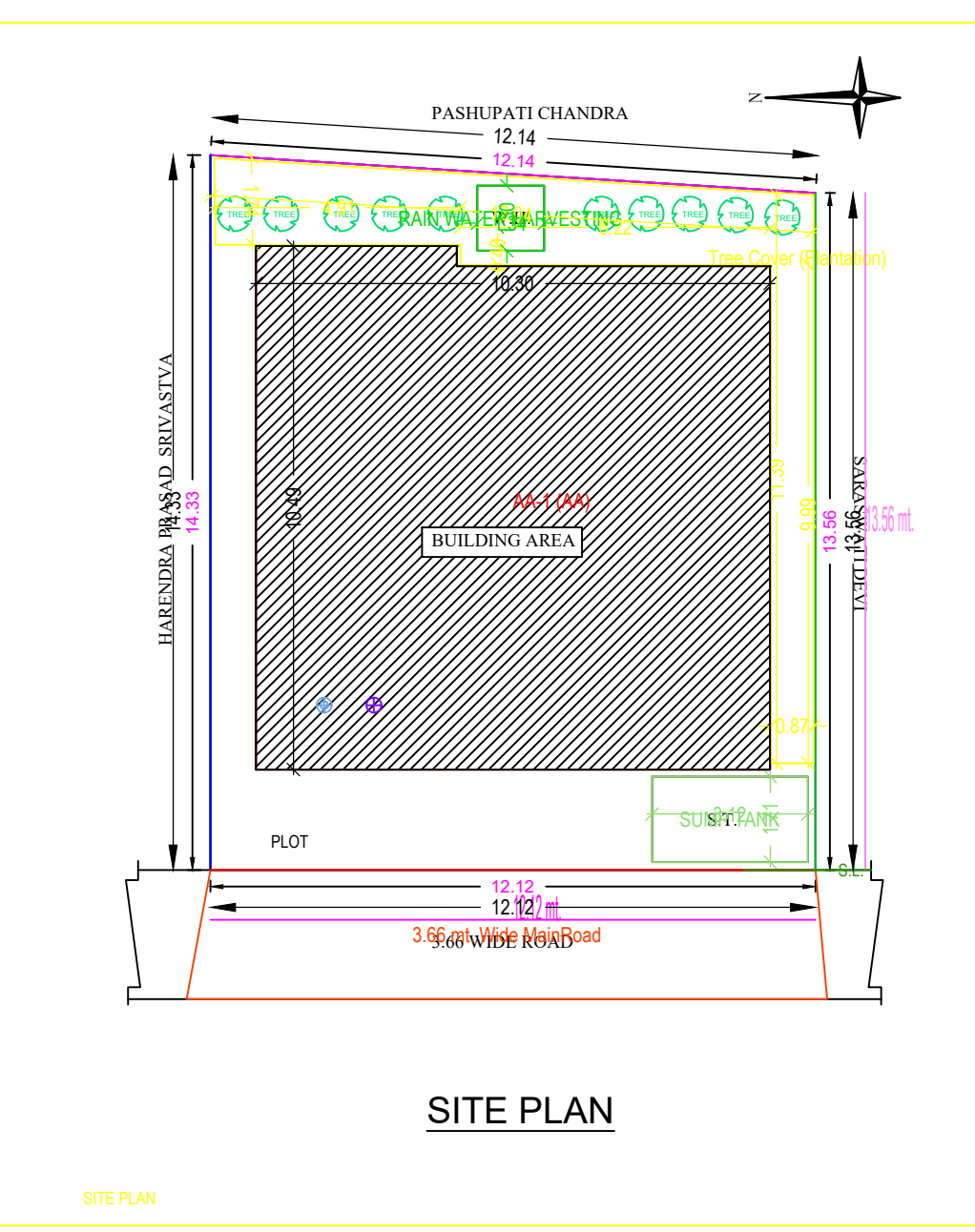

SITE PLAN

**BRIEF SPACEIFICATION**  
 FOUNDATION----- CEMENT CONCRETE (1:1.5:3)  
 BRICK WORK IN FOUNDATION & SUPERSTRUCTURE  
 FIRST CLASS BRICK WORK IN CEMENT MORTAR (1:6)  
 D.P.C.-----25 D.P.C. IN CEMENT CONCRETE (1:2:4)  
 FLOOR-----25 I.P.S. OVER 75 P.C.C.  
 ROOF-----100 THK. R.C.C. ROOF (1:1.5:3)  
 LINTEL-----150 THK. R.C.C. LINTEL (1:1.5:3)  
 STAIRS-----RISE-- 150, TREAD-- 250

**DETAILS OF AREA**  
 TOTAL AREA (AS PER DEED) ----- 179.34 SQM.  
 TOTAL AREA (AS PER SITE) ----- 168.95 SQM.  
 GROUND FLOOR AREA----- 105.49 SQM.  
 FIRST FLOOR AREA----- 105.49 SQM.  
 TOTAL COVERED AREA----- 210.98 SQM.  
 % PLINTH AREA----- 62.44 %  
 FAR ----- 1.25

**SCHEDULE**  
 D = 1.200X2.100      W = 1.800X1.200  
 D1 = 1.050X2.100      W2 = 2.400X1.200  
 D2 = 0.900X2.100      V = 0.600X0.600

**TITLE OF DRAWING**  
 PLAN OF PROPOSED RESIDENTIAL BUILDING OF  
 SMT JAYMNTI DEVI W/O SRI MAHESH PANDIT OF NEAR  
 MAHESH BHUNJA DUKAN, BEKARBAND BAND  
 POLYTECHNIC ROAD DHANBAD, P.S.- + DIST- DHANBAD,  
 UNDER MOUZA - BISHUNPUR, NO.- 5, KHATA NO.- 14,  
 NEW KHATA NO.- 16, PLOT NO.- 564 NEW PLOT NO.- 912,  
 914 IN THE DISTT. OF DHANBAD (JHARKHAND).

SIGNATURE OF OWNER

SIGNATURE OF ENGINEER

SCALE ALL DIMENSION ARE IN METRE

AREA STATEMENT		VERSION NO. - 1.0.31	
CORPORATION		VERSION DATE: 16/10/2020	
Invited No. :-	Plot Use :- Residential		
Region :- JHARKHAND URBAN LOCAL BODIES	Plot Size Use :- Single Row Dwelling / Non Apartment		
Town :- DHANBAD	Land Use Zone :- Residential		
Application Type :- General Proposal	Abutting Road Width :-		
Project Type :- Building Permission	Plot No. :-		
Nature of Development :- New	Revenue Survey No/Survey No :-		
Location :- Old Area	Thana No. :-		
Sub Location :- Nil	Healing No. :-		
Village/Moza Name :-	Khata No. :-		
Ward No. :-	North :-		
Road/Street :-	South :-		
	East :-		
	West :-		
<b>AREA DETAILS</b>		sq.MT.	
AREA OF PLOT (Minimum)	(A)	168.95	
Net Plot Area (Gross Plot Area - Deductions from Gross Plot Area)	(A Deductions)	168.95	
Deductions for Balance Plot Area (from Gross Plot Area)		27.00	
Net Plot Area (Net Plot Area - Deductions from Net Plot Area)	(A Deductions)	141.95	
Plot Area for Coverage (Net Plot Area - Road/Walking Area)	(A Deductions)	168.95	
Plot Area for FSI (Net Plot Area - Road/Walking Area)	(A Deductions)	168.95	
Proposed Coverage Area (62.44 %)		105.49	
Total Coverage Area (62.44 %)		105.49	
Proposed Area of FAR		210.98	
Total Area of FAR		210.98	
Net Proposed Build Up Area		210.98	
ARCHT / ENGRG / SUPERVISOR (Regd)	OWNER		
DEVELOPMENT AUTHORITY		LOCAL BODY	

COLOR INDEX	
PLINTH BOUNDARY	Black
ABUTTING ROAD	Green
PROPOSED WORK (COVERAGE AREA)	Red
EXISTING (To be retained)	Blue
EXISTING (To be demolished)	Yellow

Color Index		
Parking Type	Prop. No.	Prop. Area
Open Parking	1	36.45
Total Area		36.45

MARGIN DETAIL:					
Building / Wing	Road Name	Front Margin	Rear Margin	Side Margin	Side Margin
AA (AA)	3.66 mt. Wide Main Road	2.01	1.51	0.91	0.91

FAR & Tenement Details (Table 4c-1)						
Building	No. of Same Bldg	Total Built Up Area (Sq.mt.)	Deductions (Area in Sq.mt.)	Proposed FAR Area (Sq.mt.)	Total FAR Area (Sq.mt.)	Tenr (No.)
AA (AA)	1	210.98	36.45	210.98	210.98	01
Grand Total	1	210.98	36.45	210.98	210.98	01

Floor Name	Total Built Up Area (Sq.mt.)	Deductions (Area in Sq.mt.)	Proposed FAR Area (Sq.mt.)	Total FAR Area (Sq.mt.)	Tenr (No.)
Ground Floor	105.49	36.45	105.49	105.49	01
First Floor	105.49	0.00	105.49	105.49	00
Terrace Floor	0.00	0.00	0.00	0.00	00
Total	210.98	36.45	210.98	210.98	01
Total Number of Same Buildings	1				
Total	210.98	36.45	210.98	210.98	01

SCHEDULE OF JOINERY:				
BUILDING NAME	NAME	LENGTH	HEIGHT	NOS
AA (AA)	D	0.75	2.10	05
AA (AA)	D	0.30	2.10	03
AA (AA)	D	1.05	2.10	09
Total				17

SCHEDULE OF JOINERY:				
BUILDING NAME	NAME	LENGTH	HEIGHT	NOS
AA (AA)	W	0.60	1.20	04
AA (AA)	W	0.30	1.20	02
AA (AA)	W	1.00	1.20	03
AA (AA)	W	1.20	1.20	13
AA (AA)	W	1.81	1.20	01
Total				23

UnitBUA Table for Building AA (AA)						
FLOOR	Name	UnitBUA Type	UnitBUA Area	Carpet Area	No. of Rooms	No. of Tenement
GROUND FLOOR PLAN	SPLIT AA	FLAT	210.98	210.98	6	1
Total			210.98	210.98	01	1