

SITE PLAN
SCALE : 1:100

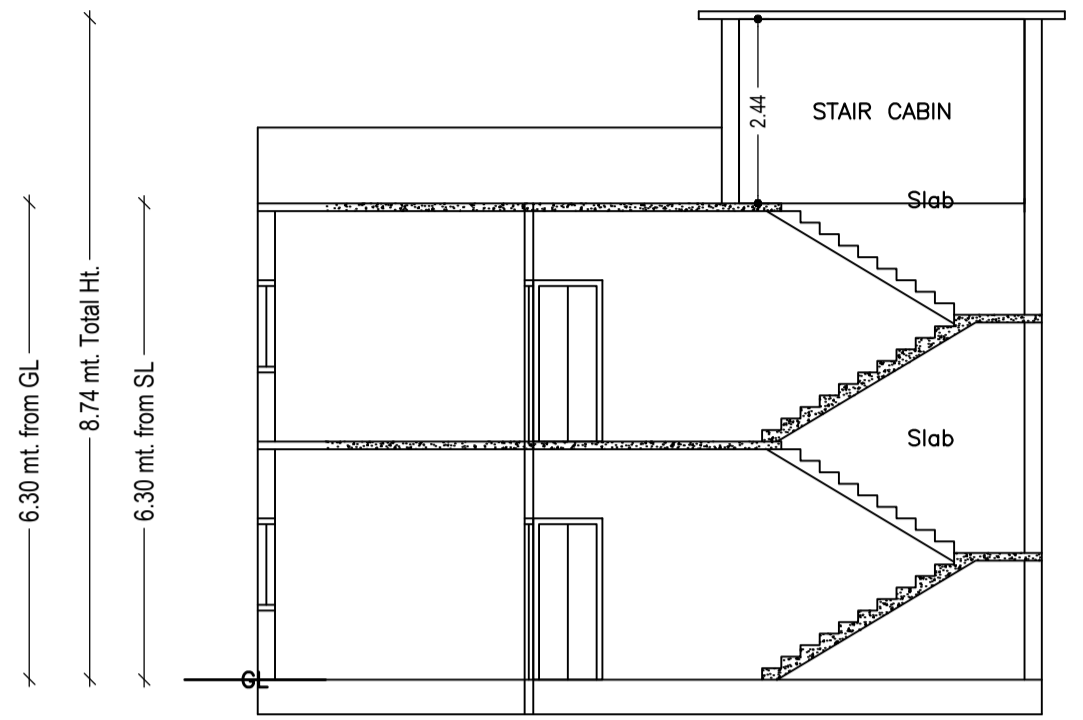

SECTION 'A-A'
SCALE : 1:100

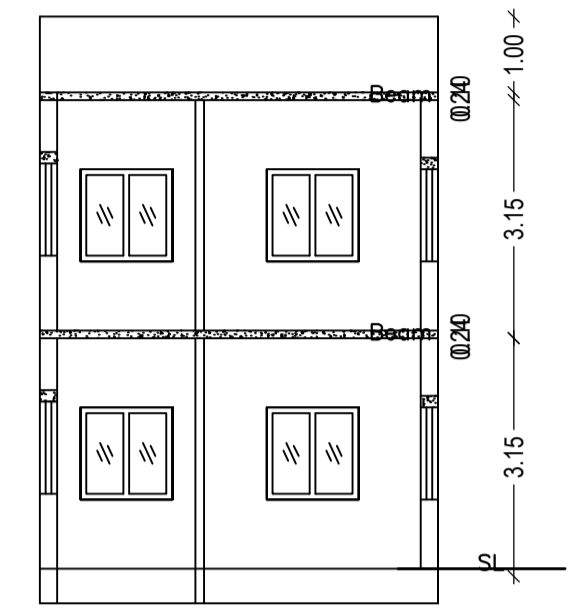

SECTION 'B-B'
SCALE : 1:100

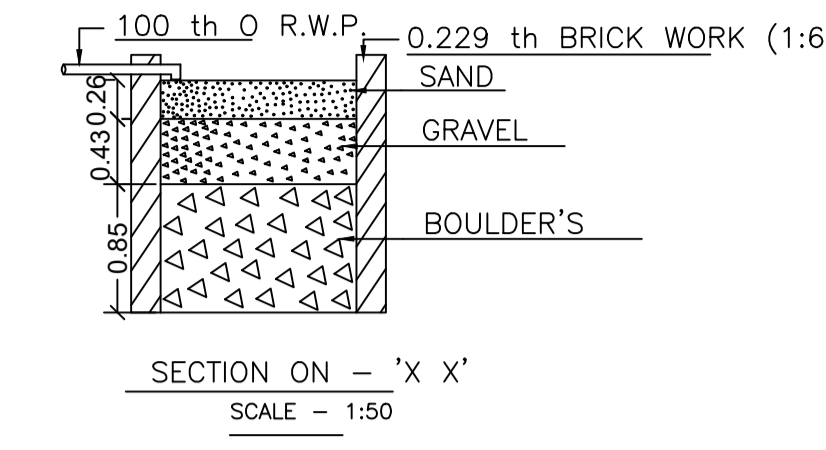

SECTION ON - 'X X'
SCALE - 1:50

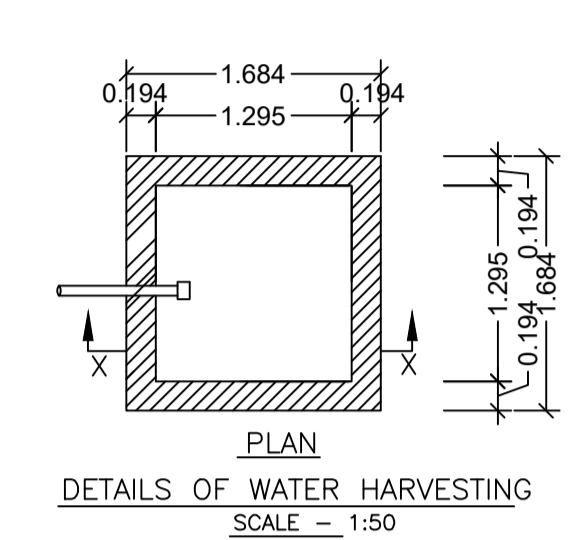

DETAILS OF WATER HARVESTING
SCALE - 1:50

ROOF TOP RAIN WATER COLLECTION SYSTEM
SCALE : NTS

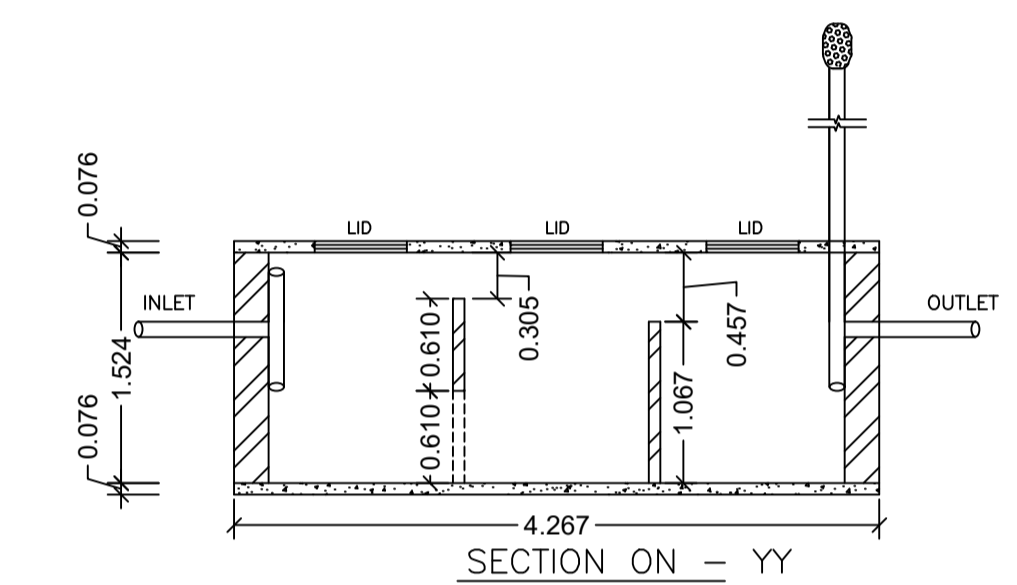

SECTION ON - YY
SCALE - 1:50

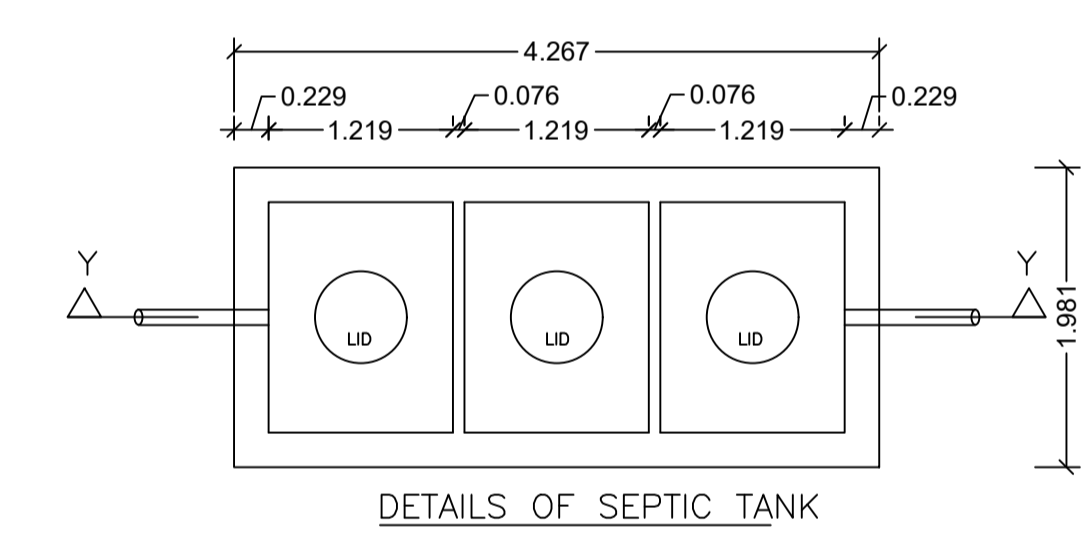

DETAILS OF SEPTIC TANK

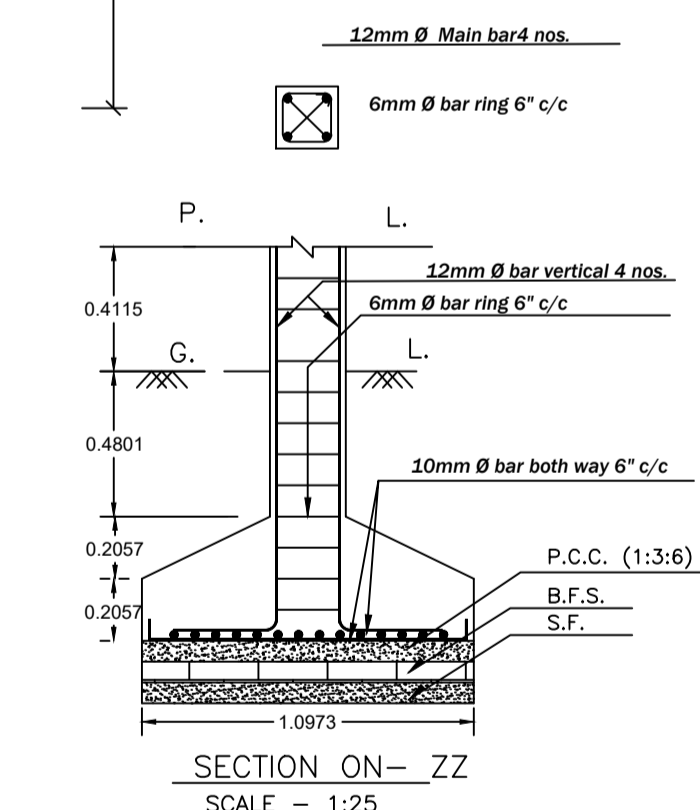

SECTION ON - ZZ
SCALE - 1:25

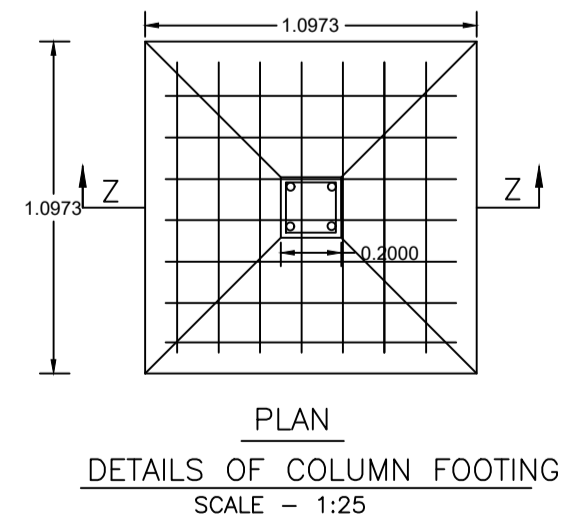

DETAILS OF COLUMN FOOTING
SCALE - 1:25

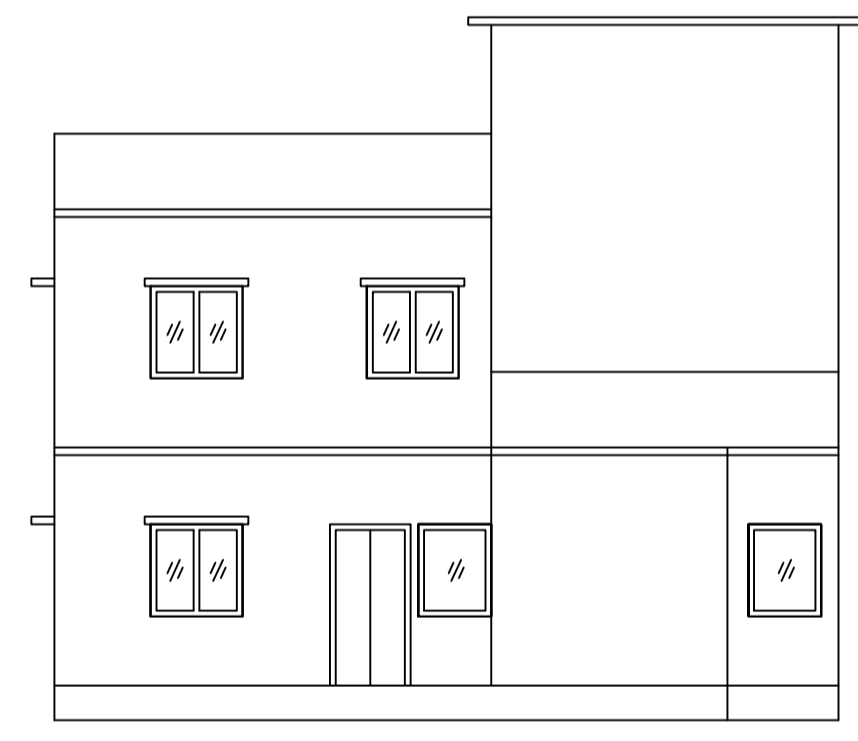

FRONT ELEVATION
SCALE : 1:100

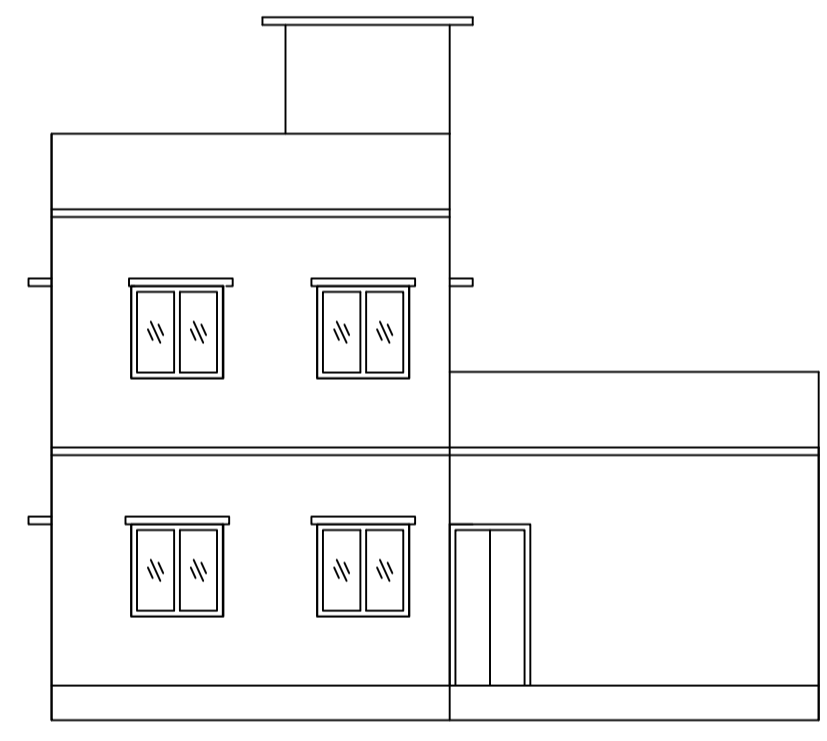

LEFT SIDE ELEVATION
SCALE : 1:100

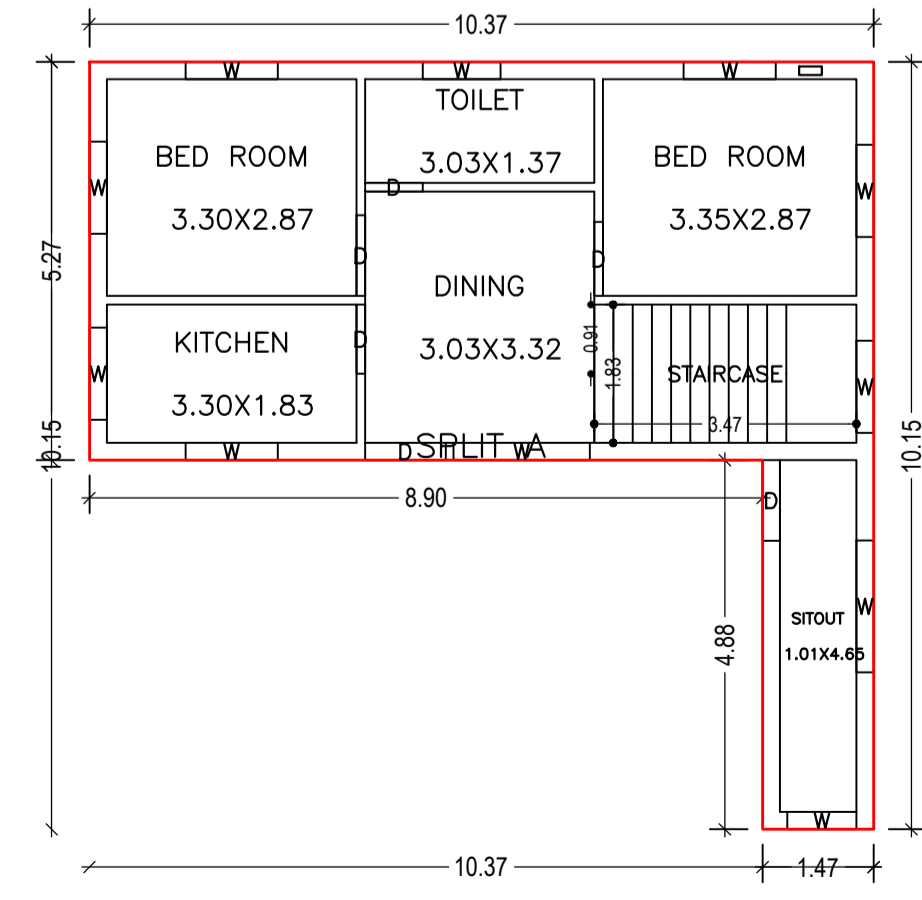

GROUND FLOOR PLAN (Proposed)
SCALE 1:100

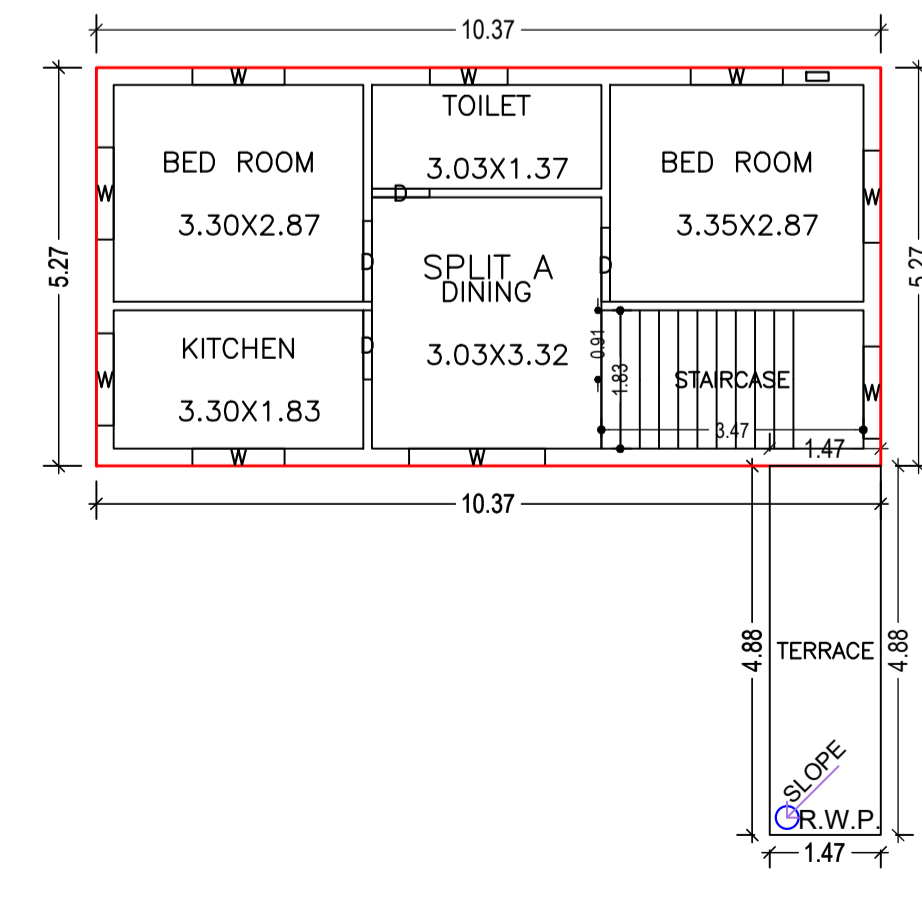

FIRST FLOOR PLAN (Proposed)
SCALE 1:100

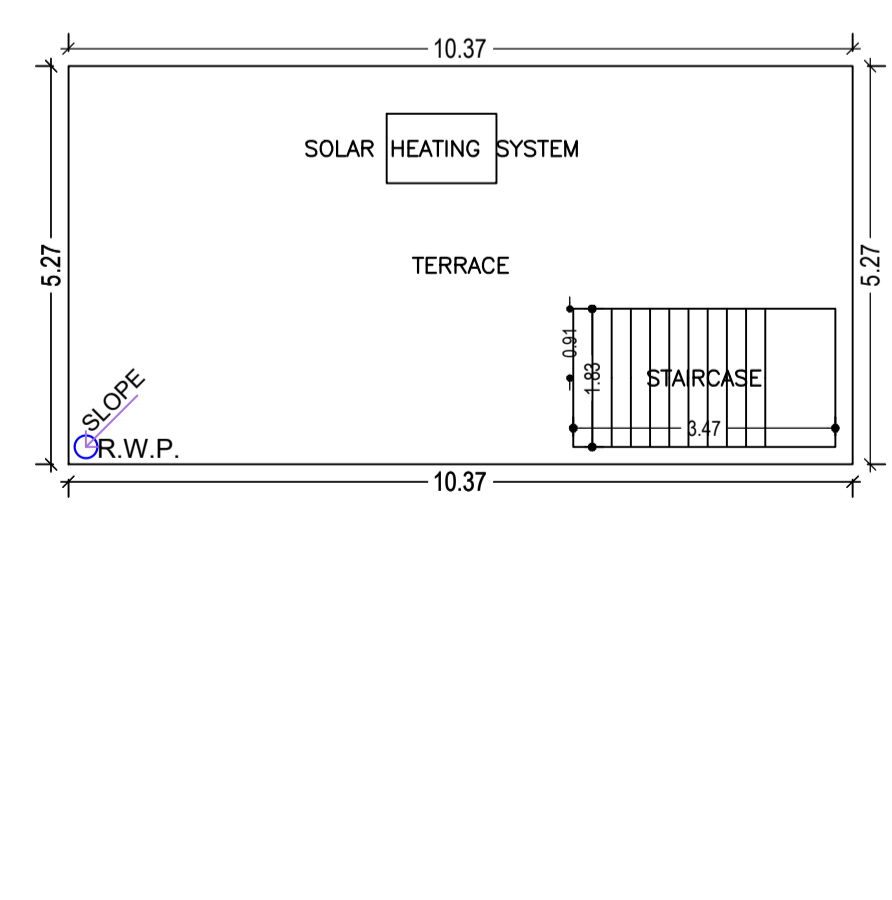

TERRACE FLOOR PLAN (Proposed)
SCALE 1:100

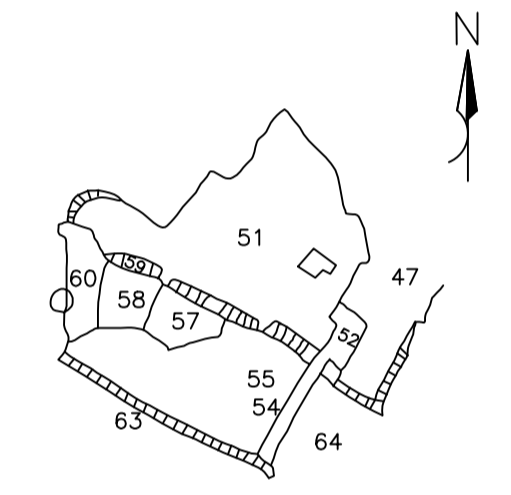

KEY PLAN
SCALE : NTS

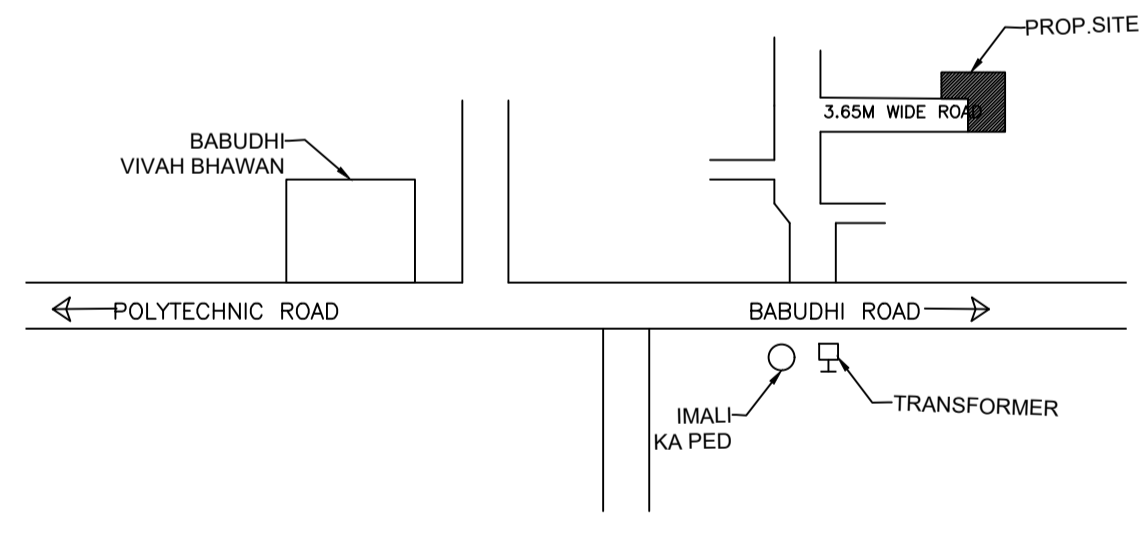

LOCATION PLAN
SCALE : NTS

SCHEDULE OF DOOR:

BUILDING NAME	NAME	LENGTH	HEIGHT	NOS
A (A)	D	0.76	2.10	02
A (A)	D	0.91	2.10	02
A (A)	D	0.98	2.10	02
A (A)	D	1.07	2.10	04

SCHEDULE OF WINDOW/VENTILATION:

BUILDING NAME	NAME	LENGTH	HEIGHT	NOS
A (A)	W	0.91	1.20	01
A (A)	W	1.03	1.20	02
A (A)	W	1.22	1.20	14
A (A)	W	1.75	1.20	01
A (A)	W	1.80	1.20	02

UnitBUA Table for Building :A (A)

FLOOR	Name	UnitBUA Type	UnitBUA Area	Carpet Area	No. of Rooms	No. of Tenement
GROUND FLOOR PLAN	SPLIT A	FLAT	116.46	116.40	6	1
FIRST FLOOR PLAN	SPLIT A	FLAT	0.00	0.00	5	0
Total	-	-	116.46	116.40	11	1

Proposal Basic Information

Proposal File No.	DMC/BP/0381/W20/2021
Owner Name	MANJU SINGH
Khata No	OLD-26, NEW-214
Plot No	OLD-51, NEW-71
Village Name	Bisanpur
Use	Residential
SubUse	Bungalow/ Dwelling / Non Apartment

AREA STATEMENT
DHANBAD MUNICIPAL CORPORATION
LOCAL BODIES

Region: JHARKHAND URBAN LOCAL BODIES	Plot Use: Residential
District: DHANBAD	Plot SubUse: Bungalow/ Dwelling / Non Apartment
Authority: DHANBAD MUNICIPAL CORPORATION	Plot/Nearby/Religious/Structure: NA
Inward No: DMC/BP/0381/W20/2021	Plot/SubPlot No: OLD-51, NEW-71
Application Type: General Proposal	North: Plot No. - 2 FEET WIDE GALI
Project Type: Building Permission	South: Plot No. - SEEMA KUMAR AND ROAD
Nature of Development: New	East: Road Width - 4.27 M WIDE ROAD
Location of Development Area: Old Area	West: Plot No. - LAND OF BADRI GOPE

AREA DETAILS:

AREA OF PLOT (Minimum)	(A)	SQ.MT.
NET AREA OF PLOT (Gross Plot Area - Deduction from Gross Plot area)	(A-Deductions)	121.55
Deduction for Balance Plot Area (from Gross Plot Area)		
Common Plot		10.41
Total		10.41
BALANCE AREA OF PLOT (Net Plot Area - Recreational/Amenity space)	(A-Deductions)	111.14
PLOT AREA FOR COVERAGE (Net Plot Area)	(A-Deductions)	121.55
Plot Area for FAR (Net Plot Area + Road Widening Area)	(A-Deductions)	121.55

COVERAGE CHECK

Permissible Coverage area (70.00 %)	85.08
Proposed Coverage Area (50.86 %)	61.82
Total Prop. Coverage Area (50.86 %)	61.82
Balance coverage area (19.14 %)	23.26

FAR CHECK

Perm. FAR Area (1.50)	182.33
Total Perm. FAR area	182.33
Residential FAR	116.46
Proposed FAR Area	116.46
Total Proposed FAR Area	116.46
Consumed FAR (Factor)	0.96
Balance FAR Area	65.87

BUILT UP AREA CHECK

Total Proposed BuiltUp Area	116.47
ARCHITECT (Regd)	SANJEEV KUMAR RAY
ENGINEER (Regd)	
SUPERVISOR (Regd)	
OWNER (Regd)	MANJU SINGH
DEVELOPMENT AUTHORITY	LOCAL BODY

COLOR INDEX

- PLOT BOUNDARY
- ABUTTING ROAD
- PROPOSED CONSTRUCTION
- COMMON PLOT
- ROAD WIDENING AREA
- EXISTING (To be retained)
- EXISTING (To be demolished)

Buildingwise Floor FAR Details

Floor Name	Building Name		Total	
	Proposed Built Up Area (Sq.mt.)	Proposed FAR Area (Sq.mt.)	Total Proposed Built Up Area (Sq.mt.)	Total FAR Area (Sq.mt.)
Ground Floor	61.82	61.82	61.82	61.82
First Floor	54.65	54.65	54.65	54.65
Terrace Floor	0.00	0.00	0.00	0.00
Total:	116.47	116.47	116.47	116.47

Building USE/SUBUSE Details

Building Name	Building Use	Building SubUse	Building Structure
A (A)	Residential	Residential Bldg/Apartment	Non-Highrise

FAR & Tenement Details (Table 4c-1)

Building	No. of Same Bldg	Total Built Up Area (Sq.mt.)	Proposed FAR Area (Sq.mt.) Resi.	Total FAR Area (Sq.mt.)	Total Consumed Additional FAR Area (Sq.mt.)	Tnmt (No.)
A (A)	1	116.47	116.47	116.47	116.47	01
Grand Total :	1	116.47	116.47	116.47	116.47	01

Building :A (A)

Floor Name	Total Built Up Area (Sq.mt.)	Proposed FAR Area (Sq.mt.) Resi.	Total FAR Area (Sq.mt.)	Total Consumed Additional FAR Area (Sq.mt.)	Tnmt (No.)
Ground Floor	61.82	61.82	61.82	61.82	01
First Floor	54.65	54.65	54.65	54.65	00
Terrace Floor	0.00	0.00	0.00	0.00	00
Total	116.47	116.47	116.47	116.47	01
Total Number of Same Buildings	1				
Total :	116.47	116.47	116.47	116.47	01

LTP NAME AND SIGNATURE	STRUCTURAL ENG'S NAME AND SIGNATURE	BUILDER NAME AND SIGNATURE	DIGITAL SIGNATURE
SANJEEV KUMAR RAY DMC/ENG/0001/2019			