

SITE PLAN

site plan

SCHEDULE OF DOOR:

BUILDING NAME	NAME	LENGTH	HEIGHT	NOS
A (A)	D	0.90	2.10	18

SCHEDULE OF WINDOW/VENTILATION:

BUILDING NAME	NAME	LENGTH	HEIGHT	NOS
A (A)	V	0.78	1.20	02
A (A)	W	1.19	1.20	04
A (A)	W	1.72	1.20	02
A (A)	W	1.80	1.20	16

Building :A (A)

Floor Name	Total Built Up Area (Sq.mt.)	Proposed FAR Area (Sq.mt.) Resi.	Total FAR Area (Sq.mt.)	Total Consumed Additional FAR Area (Sq.mt.)	Trmt (No.)
Ground Floor	150.31	150.31	150.31	150.31	01
First Floor	150.31	150.31	150.31	150.31	00
Terrace Floor	0.00	0.00	0.00	0.00	00
Total :	300.62	300.62	300.62	300.62	01
Total Number of Same Buildings :	1				
Total :	300.62	300.62	300.62	300.62	01

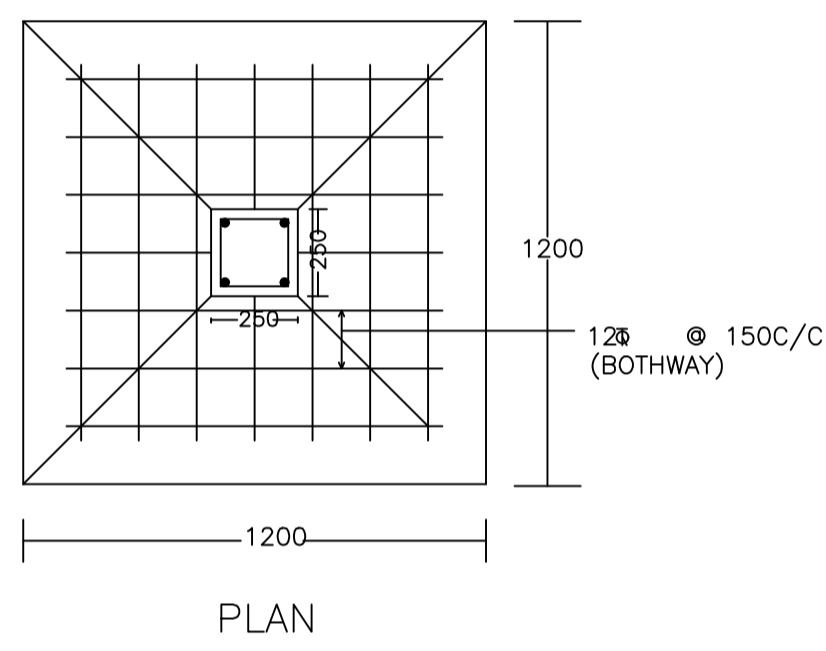
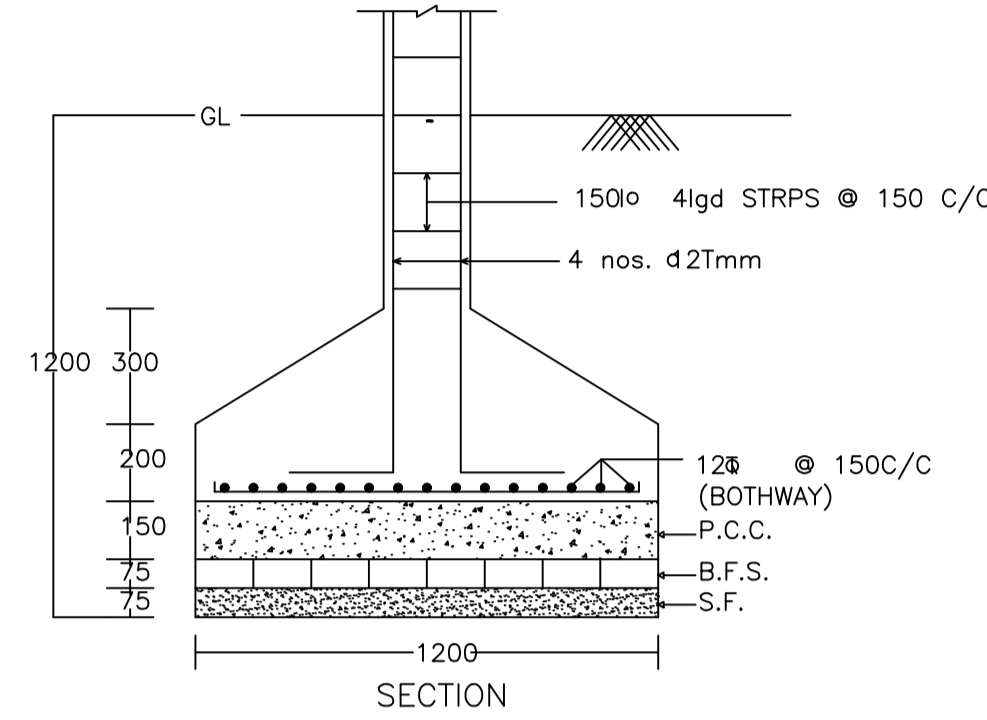
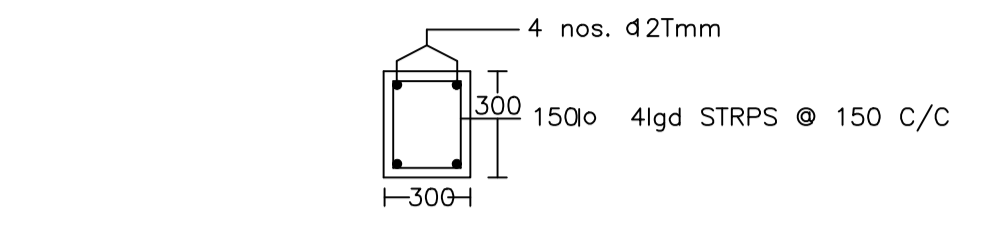

DETAIL OF COLUMNS

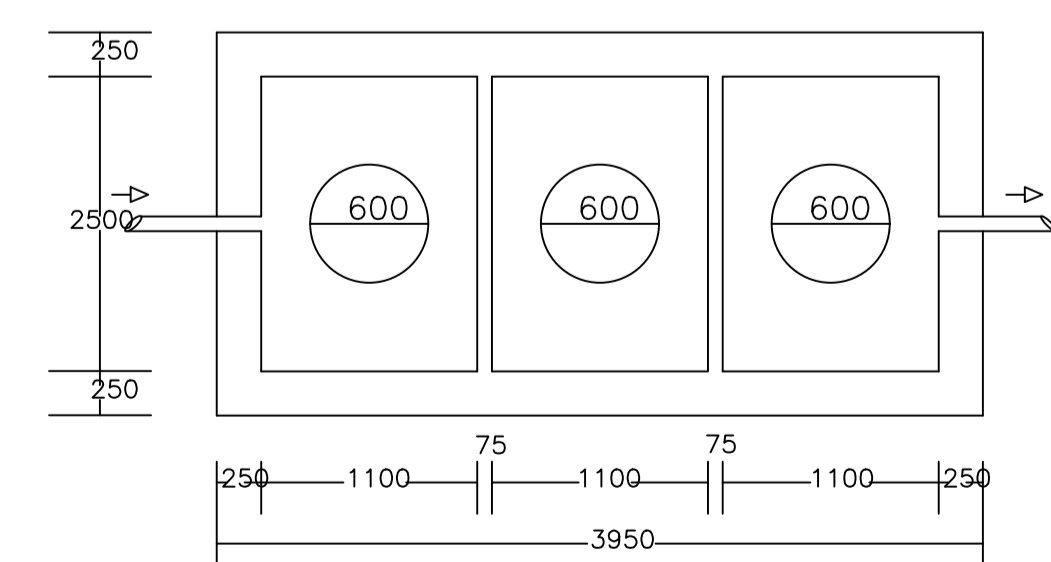
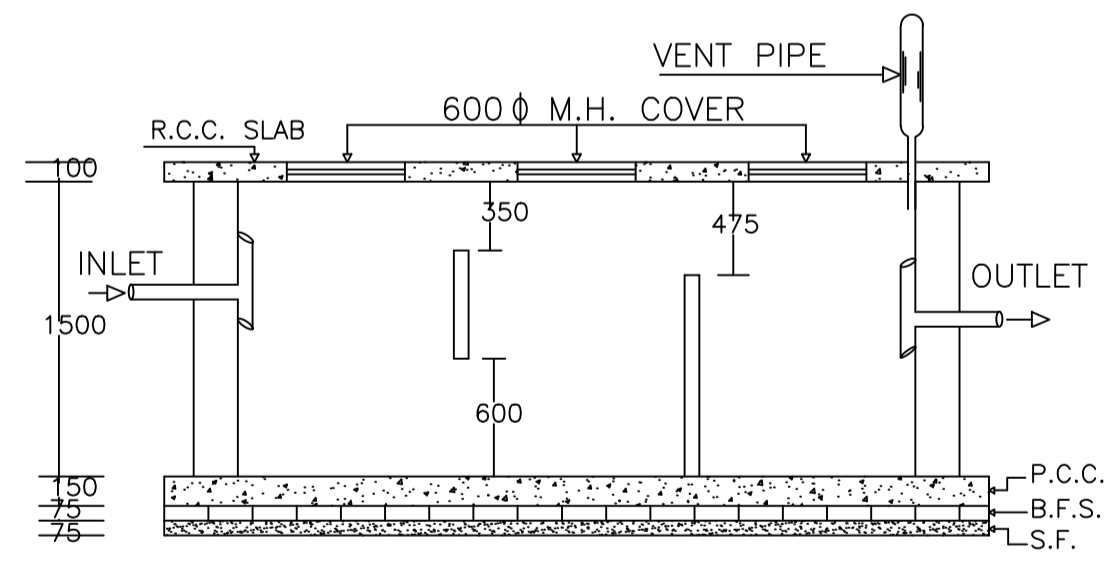

PLAN OF SEPTIC TANK

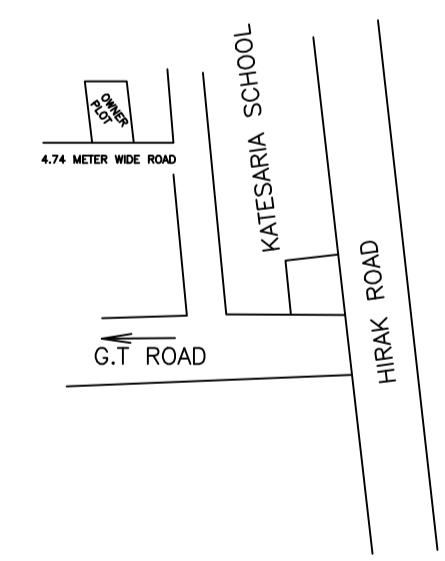
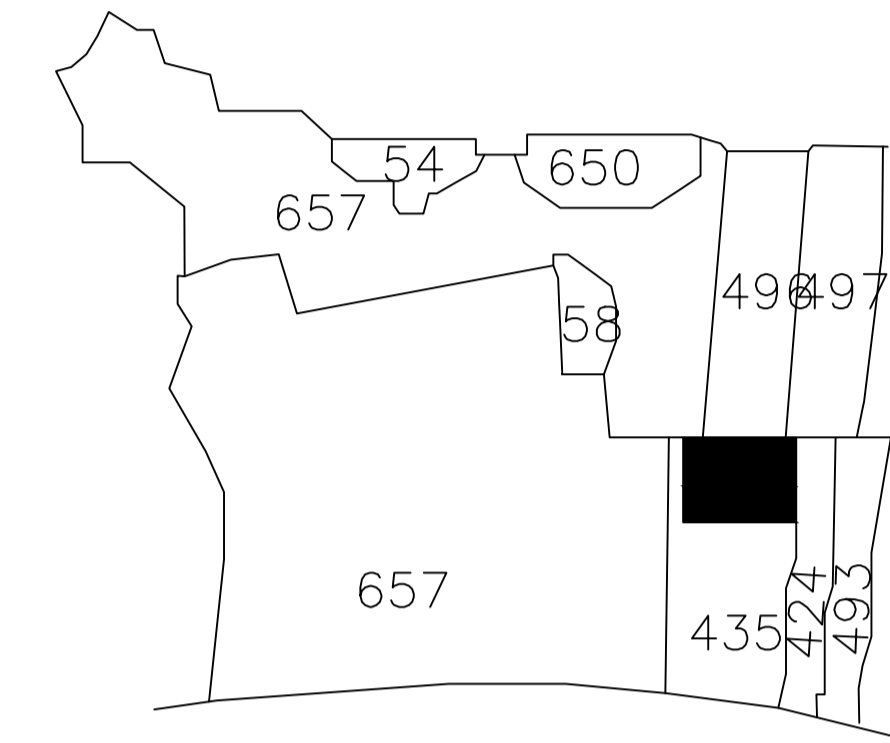

Proposal Basic Information

Proposal File No.	DMC/BP/0006/W22/2021
Owner Name	Niraj kumar
Khata No	57(new : 33)
Plot No	495(new:498)
Village Name	Bhelaland
Use	Residential
SubUse	Bungalow/ Dwelling / Non Apartment

AREA STATEMENT		VERSION NO. : 1.0.55
CORPORATION		VERSION DATE: 16/10/2020
PROJECT DETAIL:		
Region : JHARKHAND URBAN LOCAL BODIES	Plot Use: Residential	
District: DHANBAD	Plot SubUse: Bungalow/ Dwelling / Non Apartment	
Authority: DHANBAD MUNICIPAL CORPORATION	PlotNearby/ReligiousStructure: NA	
Inward_No: DMC/BP/0006/W22/2021	Plot/SubPlot No: 495(new:498)	
Application Type: General Proposal	North: Plot No. - 496	
Project Type: Building Permission	South: Plot No. - same plot	
Nature of Development: New	East: Plot No. - 494	
Location of Development Area: Old Area	West: Road Width - 4.84	
AREA DETAILS:		
AREA OF PLOT (Minimum)	(A)	SQ.MT. 525.46
NET AREA OF PLOT(Gross Plot Area - Deduction from Gross Plot area)	(A-Deductions)	525.46
Deduction for Balance Plot Area(from Gross Plot Area)		
Common Plot		95.95
Total		95.95
BALANCE AREA OF PLOT(Net Plot Area - Recreational/Amenity space)	(A-Deductions)	429.51
PLOT AREA FOR COVERAGE(Net Plot Area)	(A-Deductions)	525.46
Plot Area for FAR (Net Plot Area + Road/Widening Area)	(A-Deductions)	525.46
COVERAGE CHECK		
Permissible Coverage area (60.00 %)		315.28
Proposed Coverage Area (28.61 %)		150.31
Total Prop. Coverage Area (28.61 %)		150.31
Balance coverage area (31.40 %)		164.97
FAR CHECK		
Perm. FAR Area (1.50)		788.19
Total Perm. FAR area		788.19
Residential FAR		300.61
Proposed FAR Area		300.61
Total Proposed FAR Area		300.61
Consumed FAR (Factor)		0.57
Balance FAR Area		487.58
BUILT UP AREA CHECK		
Total Proposed BuiltUp Area		300.62
ARCHITECT (Regd)	PARTHA - PAL	
ENGINEER (Regd)		
SUPERVISOR (Regd)		
OWNER (Regd)	Niraj kumar	
DEVELOPMENT AUTHORITY LOCAL BODY		

COLOR INDEX	
PLOT BOUNDARY	Black
ABUTTING ROAD	Green
PROPOSED CONSTRUCTION	Red
COMMON PLOT	Yellow
ROAD WIDENING AREA	Blue
EXISTING (To be retained)	Light Blue
EXISTING (To be demolished)	Light Yellow

Buildingwise Floor FAR Details

Floor Name	Building Name A (A)		Total	
	Proposed Built Up Area (Sq.mt.)	Proposed FAR Area (Sq.mt.)	Total Proposed Built Up Area (Sq.mt.)	Total FAR Area (Sq.mt.)
Ground Floor	150.31	150.31	150.31	150.31
First Floor	150.31	150.31	150.31	150.31
Terrace Floor	0.00	0.00	0.00	0.00
Total :	300.62	300.62	300.62	300.62

Building USE/SUBUSE Details

Building Name	Building Use	Building SubUse	Building Structure
A (A)	Residential	Bungalow/ Dwelling / Non Apartment	Non-Highrise

FAR & Tenement Details (Table 4c-1)

Building	No. of Same Bldg	Total Built Up Area (Sq.mt.)	Proposed FAR Area (Sq.mt.)	Total FAR Area (Sq.mt.)	Total Consumed Additional FAR Area (Sq.mt.)	Trmt (No.)
A (A)	1	300.62	300.62	300.62	300.62	01
Grand Total :	1	300.62	300.62	300.62	300.62	01

UnitBUA Table for Building :A (A)

FLOOR	Name	UnitBUA Type	UnitBUA Area	Carpet Area	No. of Rooms	No. of Tenement
GROUND FLOOR PLAN	SPLIT FLAT - A	FLAT	300.61	300.54	9	1
FIRST FLOOR PLAN	SPLIT FLAT - A	FLAT	0.00	0.00	9	0
Total:	-	-	300.61	300.54	18	1

LTP NAME AND SIGNATURE	STRUCTURAL ENG'S NAME AND SIGNATURE	BUILDER NAME AND SIGNATURE	DIGITAL SIGNATURE
PARTHA - PAL DMC/ENG/0021/2016			

Proposal Basic Information

Proposal File No.	DMC/BP/0006/W22/2021
Owner Name	Niraj kumar
Khata No	57(new : 33)
Plot No	495(new:498)
Village Name	Bhelaland
Use	Residential
SubUse	Bungalow/ Dwelling / Non Apartment

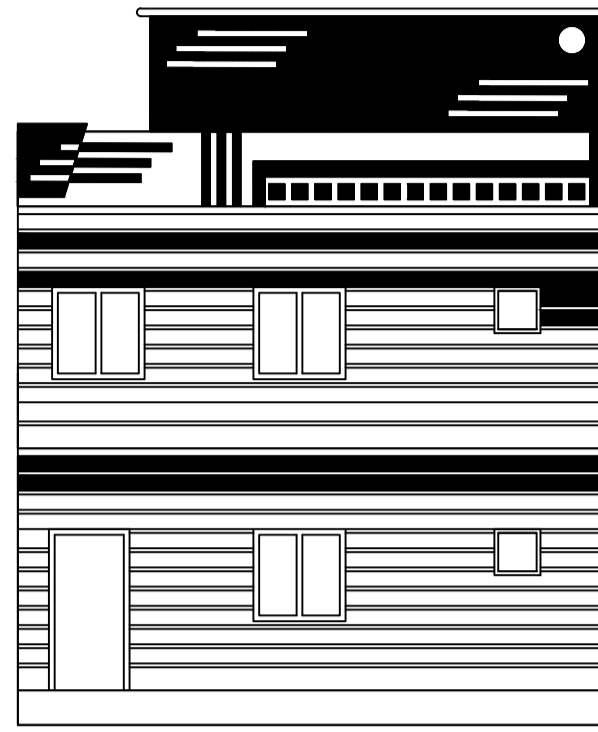

FRONT ELEVATION

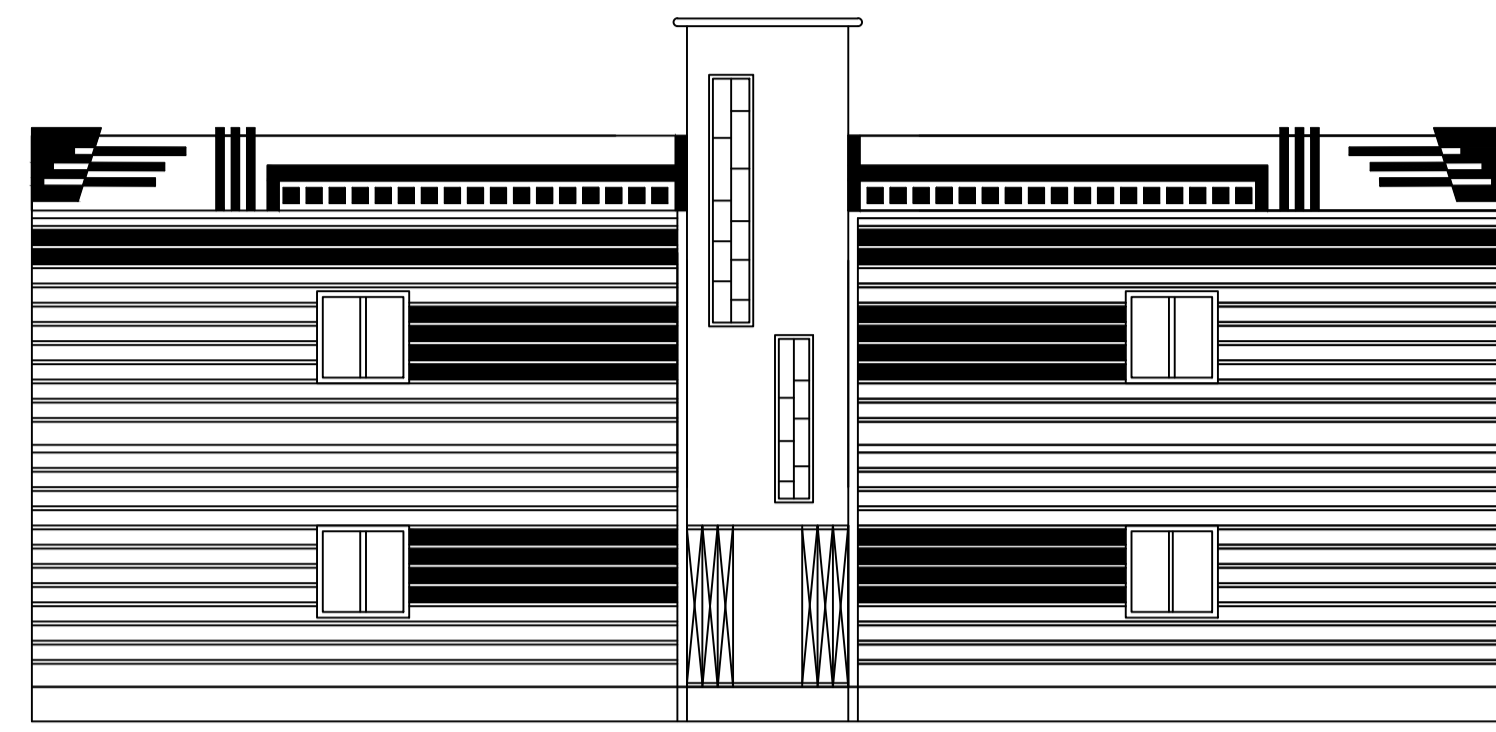

LEFT SIDE ELEVATION

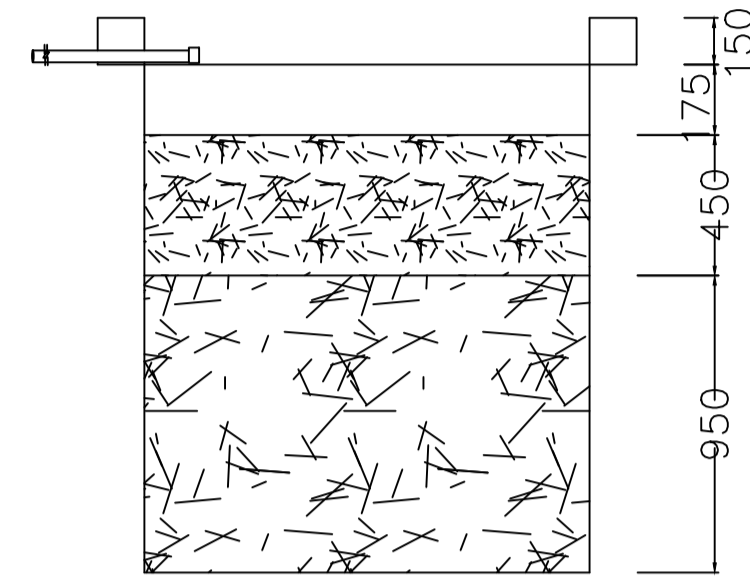

SECTION AT Y-Y

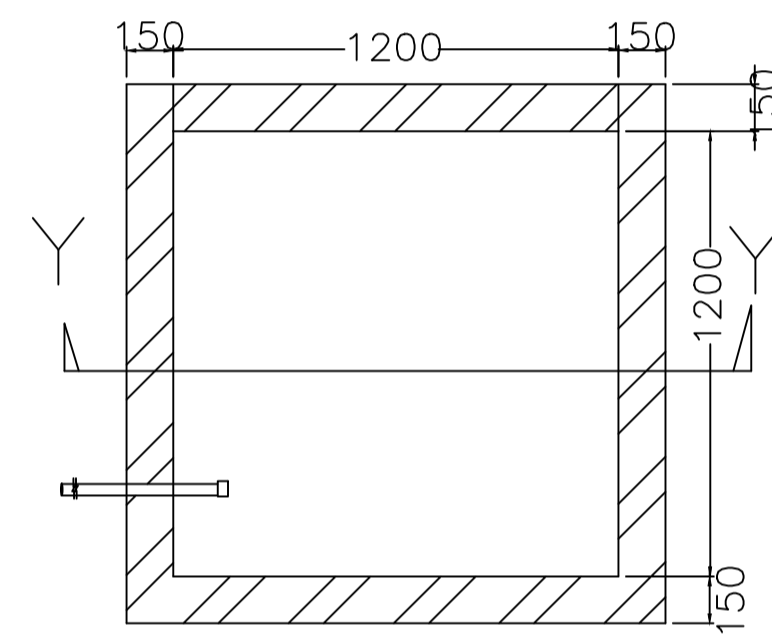

PLAN OF RECHARGE WELL

WATER HARVESTING

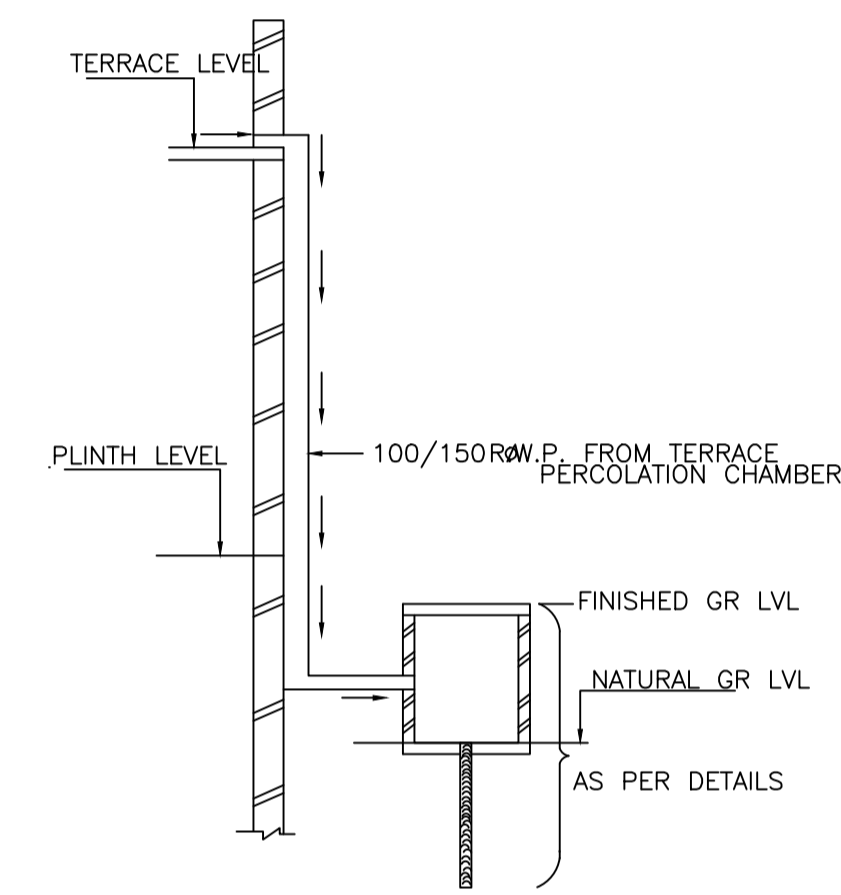

ROOF TOP RAIN WATER COLLECTION SYSTEM

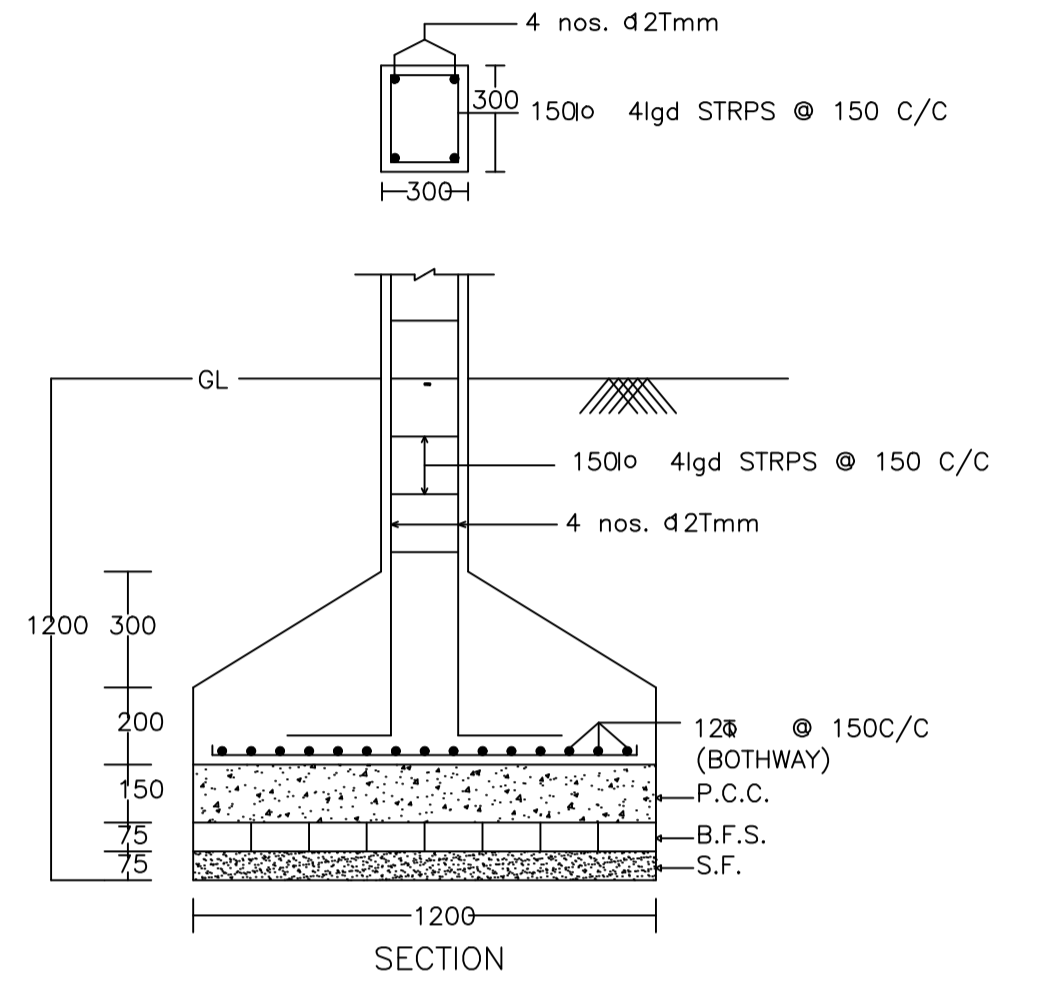

SECTION

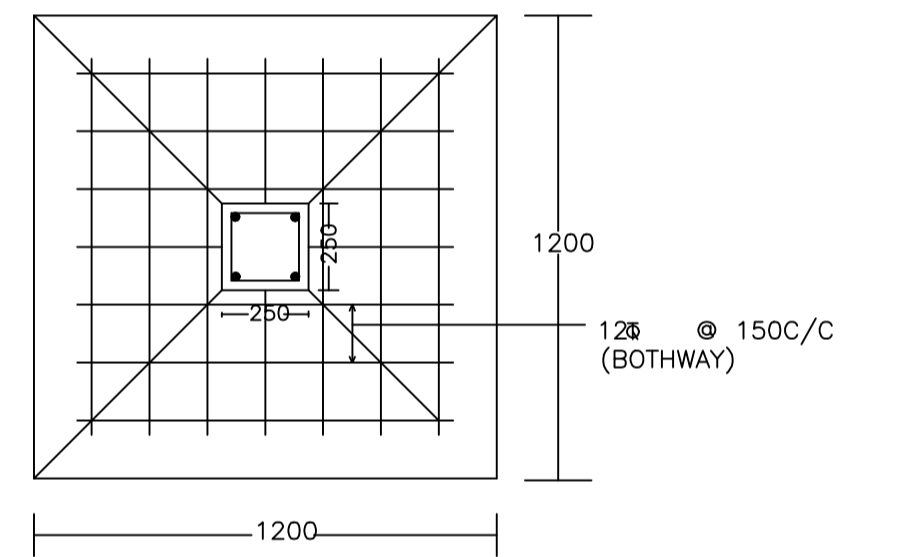

PLAN

DETAIL OF COLUMNS

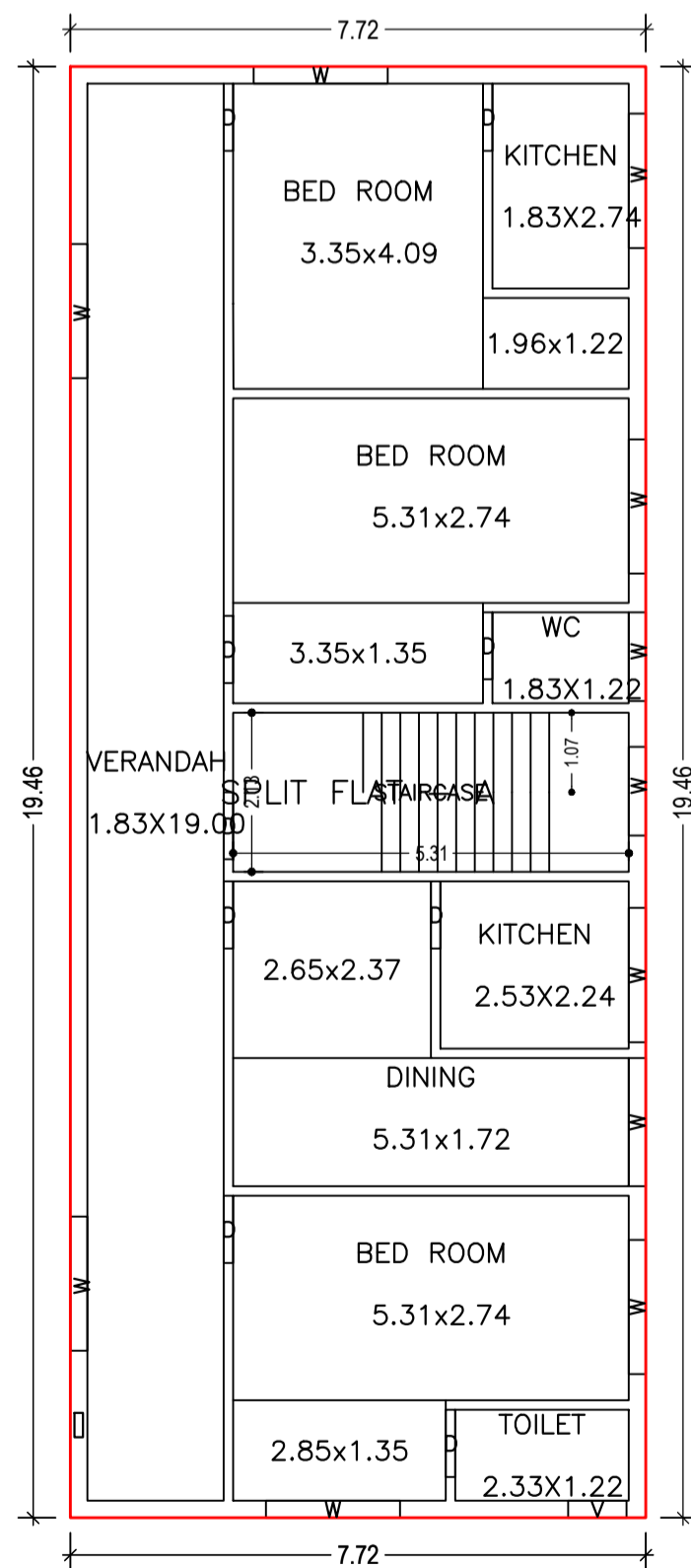

GROUND FLOOR PLAN (Proposed) (SCALE 1:100)

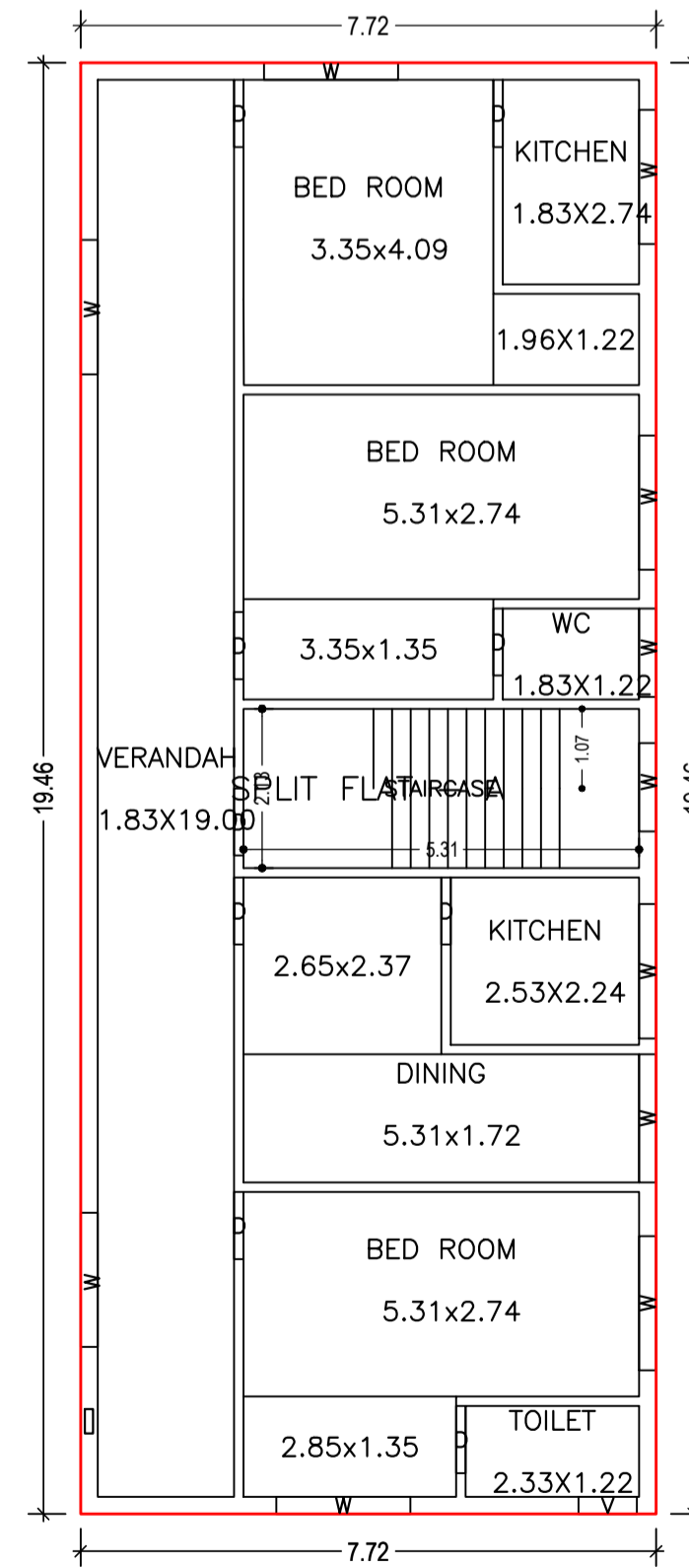

FIRST FLOOR PLAN (Proposed) (SCALE 1:100)

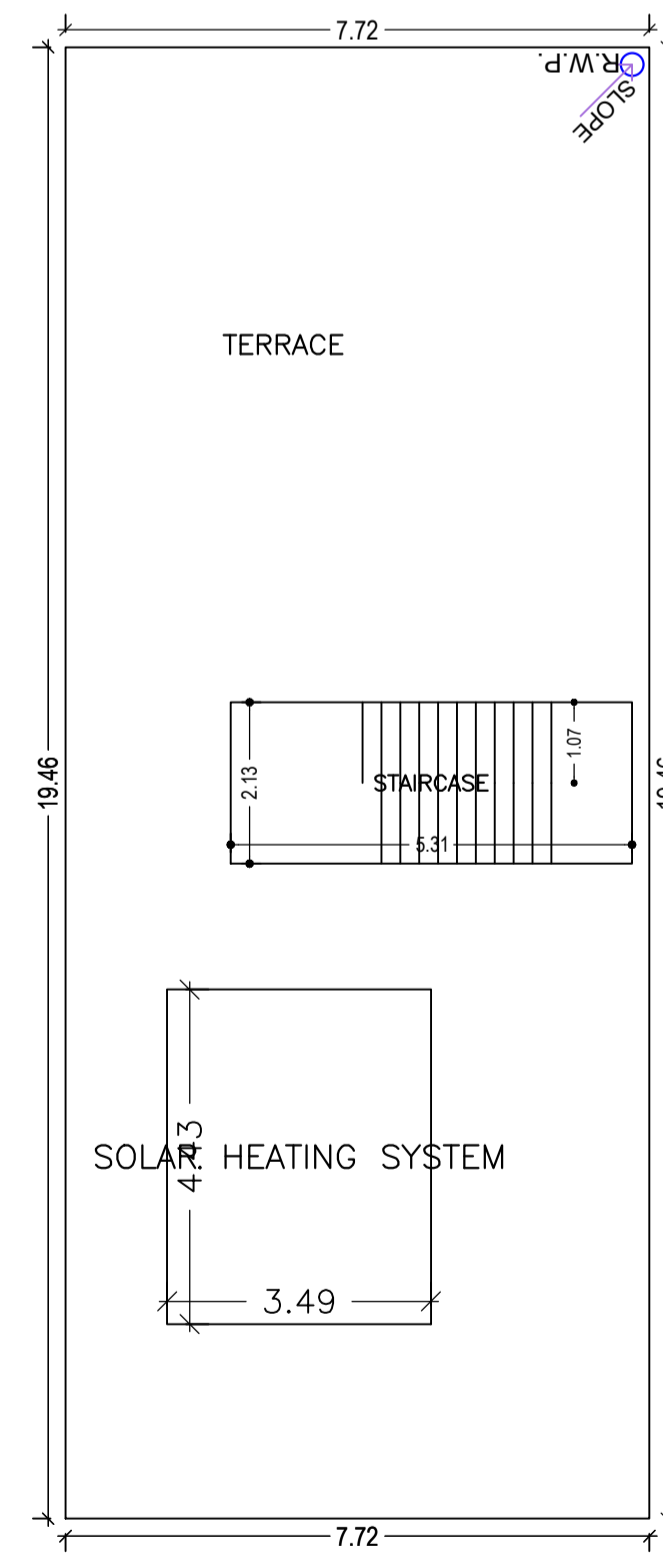

TERRACE FLOOR PLAN (SCALE 1:100)

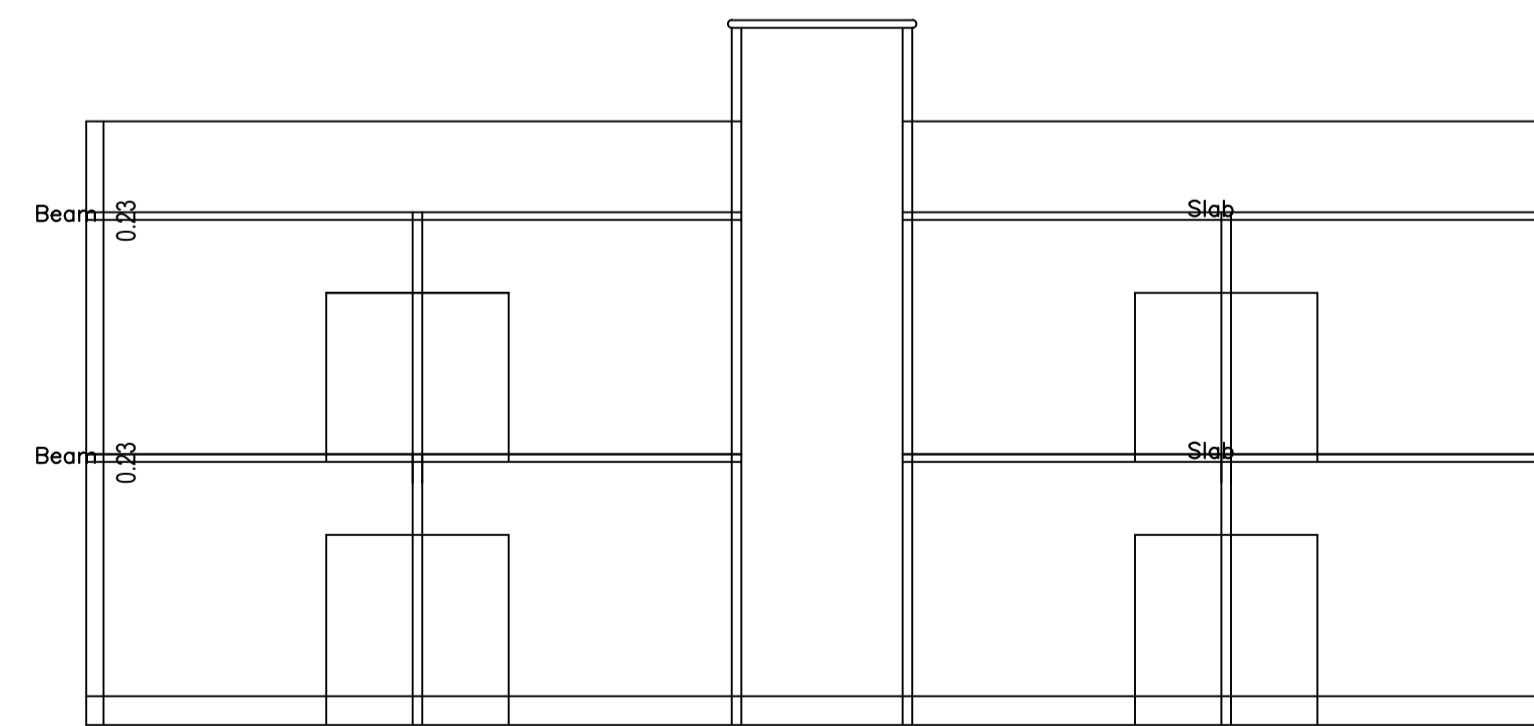

SECTION ON X-X

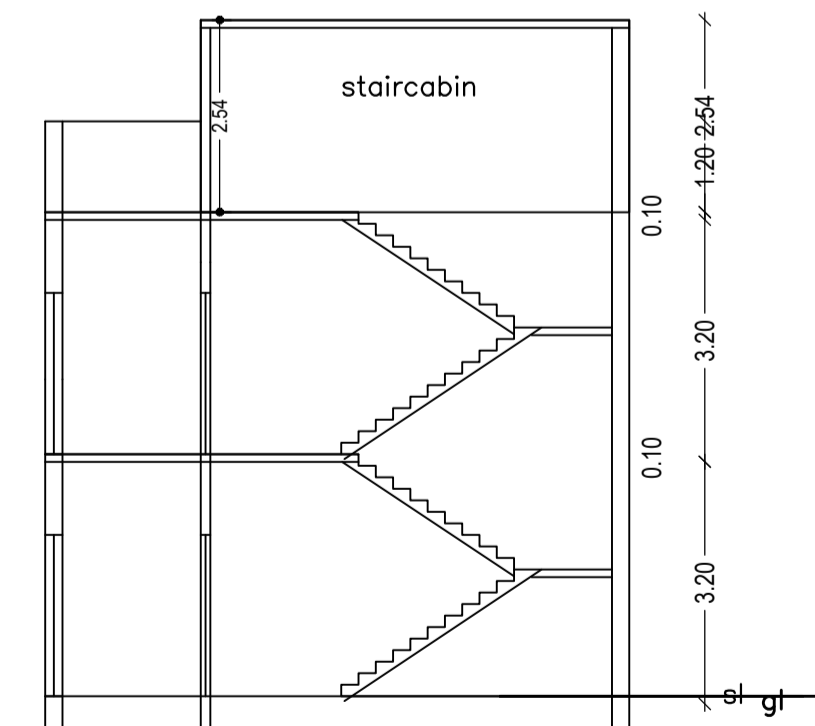

SECTION ON Y-Y

LTP NAME AND SIGNATURE	STRUCTURAL ENG'S NAME AND SIGNATURE	BUILDER NAME AND SIGNATURE	DIGITAL SIGNATURE
PARTHA - PAL DMC/ENG/0021/2016			