

site plan

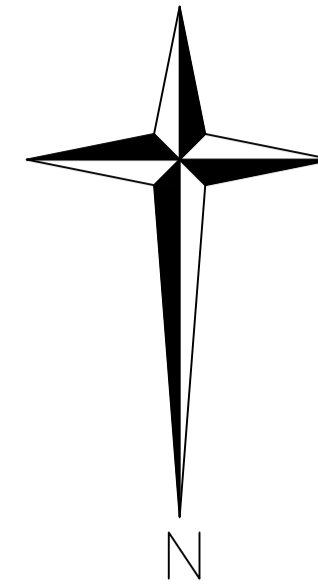
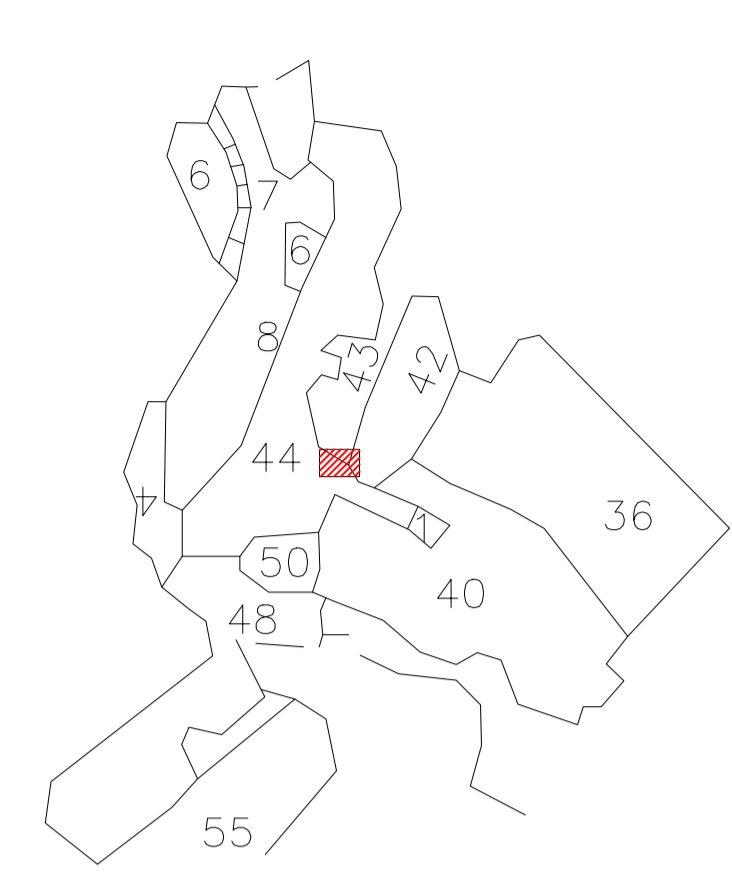
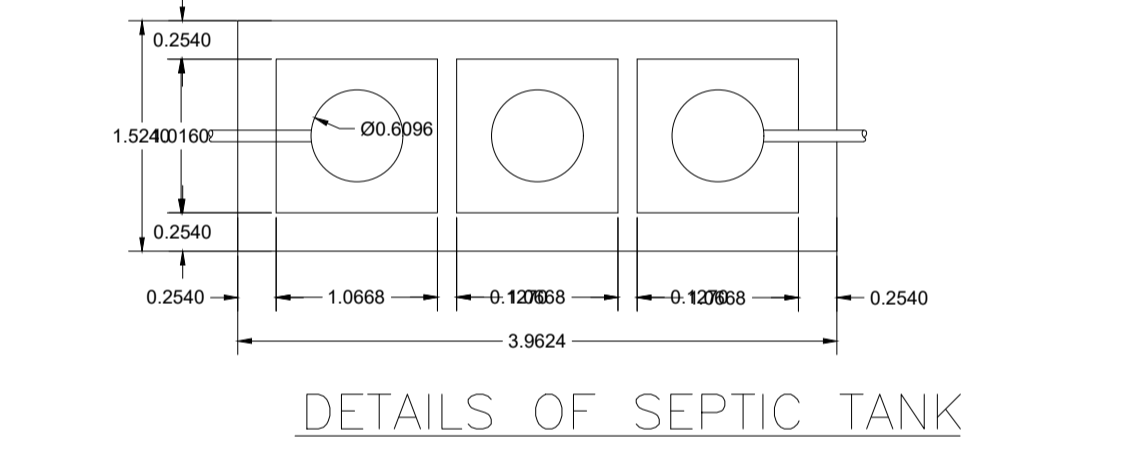
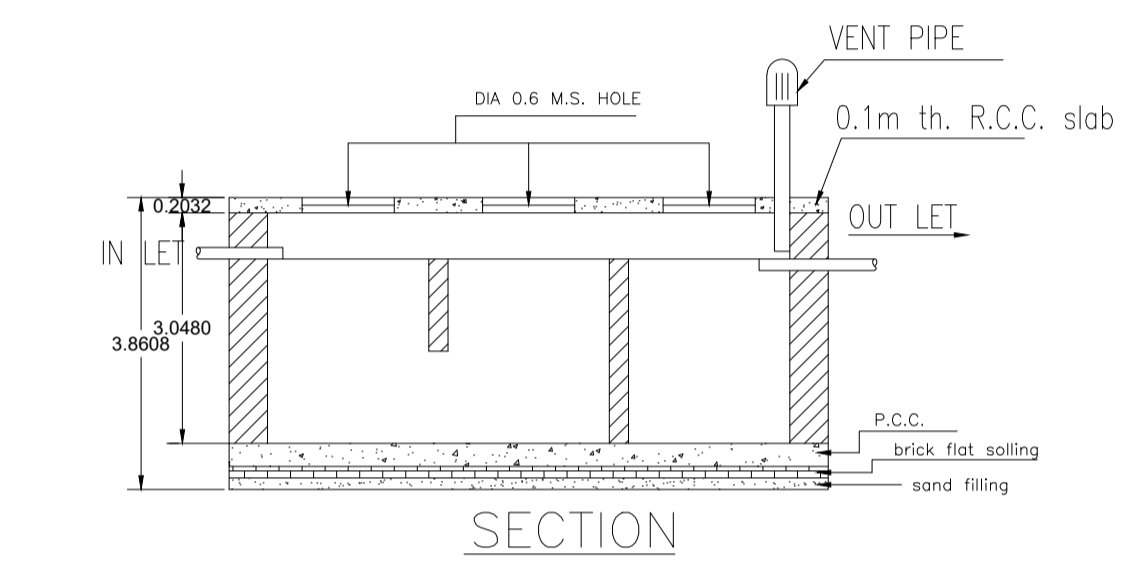
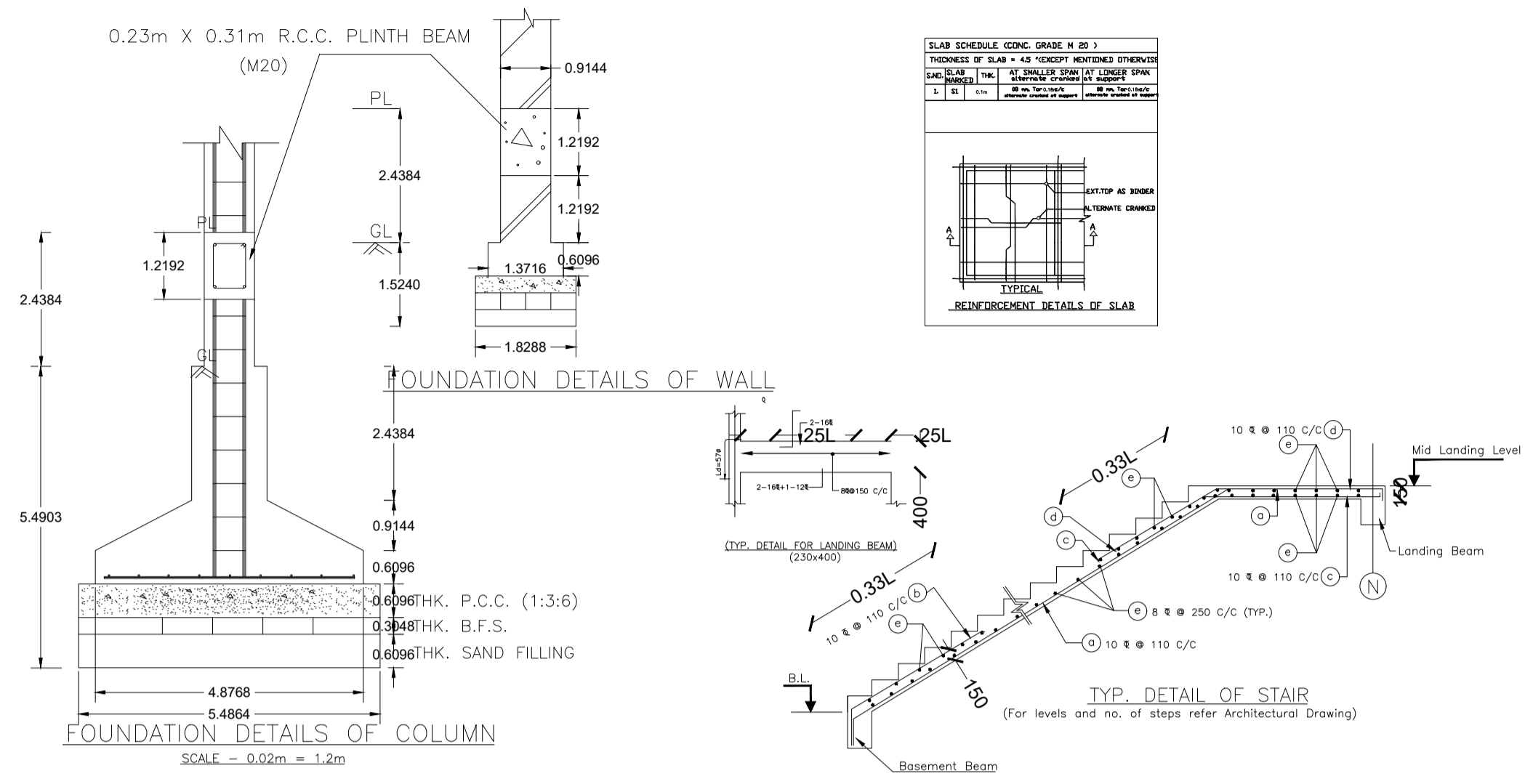

Proposal Basic Information

Proposal File No.	DMC/BP/0232/W23/2021
Owner Name	Smt. Anju Sharma
Khata No	76 (NEW 271.91)
Plot No	42,43,44 ( NEW 17,67,18)
Village Name	Kolakusma
Use	Residential
SubUse	Bungalow/ Dwelling / Non Apartment

AREA STATEMENT  
DHANBAD MUNICIPAL CORPORATION

VERSION NO.: 1.0.61  
VERSION DATE: 16/10/2020

Region: JHARKHAND URBAN LOCAL BODIES	Plot Use: Residential
District: DHANBAD	Plot SubUse: Bungalow/ Dwelling / Non Apartment
Authority: DHANBAD MUNICIPAL CORPORATION	Plot/Nearby/Religious/Structure: NA
Inward No: DMC/BP/0232/W23/2021	North: Road Width - 4.57
Application Type: General Proposal	South: Plot No. - 43 & 44
Project Type: Building Permission	East: Plot No. - 19 (P)
Nature of Development: New	West: Plot No. - PADMA LOCHAN PD. SINHA
Location of Development Area: Old Area	

AREA OF PLOT (Minimum)	(A)	SQ.MT.	334.49
NET AREA OF PLOT(Gross Plot Area - Deduction from Gross Plot area)	(A-Deductions)		334.49
Deduction for Balance Plot Area(from Gross Plot Area)			
Common Plot			19.32
Total			19.32
BALANCE AREA OF PLOT(Net Plot Area - Recreational/Amenity space)	(A-Deductions)		315.17
PLOT AREA FOR COVERAGE(Net Plot Area)	(A-Deductions)		334.49
Plot Area for FAR (Net Plot Area + Road Widening Area)	(A-Deductions)		334.49

COVERAGE CHECK			
Permissible Coverage area ( 60.00 % )			200.69
Proposed Coverage Area ( 49.70 % )			166.23
Total Prop. Coverage Area ( 49.7 % )			166.23
Balance coverage area ( 10.30 % )			34.46

FAR CHECK			
Perm. FAR Area ( 1.50 )			501.73
Total Perm. FAR area			501.73
Residential FAR			498.68
Proposed FAR Area			498.68
Total Proposed FAR Area			498.68
Consumed FAR (Factor)			1.49
Balance FAR Area			3.05

BUILT UP AREA CHECK			
Total Proposed BuiltUp Area			498.69
ARCHITECT (Regd)			
ARCHITECT (Regd)		SUSHIL KUMAR	
ENGINEER (Regd)			
ENGINEER (Regd)			
SUPERVISOR (Regd)			
SUPERVISOR (Regd)			
OWNER (Regd)			
OWNER (Regd)		Smt. Anju Sharma	
DEVELOPMENT AUTHORITY			
DEVELOPMENT AUTHORITY		LOCAL BODY	

Building USE/SUBUSE Details

Building Name	Building Use	Building SubUse	Building Structure
A (1)	Residential	Residential Bldg/Apartment	Non-Highrise

FAR & Tenement Details (Table 4c-1)

Building	No. of Same Bldg	Total Built Up Area (Sq.mt.)	Proposed FAR Area (Sq.mt.) Res.	Total FAR Area (Sq.mt.)	Total Consumed Additional FAR Area (Sq.mt.)	Tnmt (No.)
A (1)	1	498.69	498.69	498.69	498.69	01
Grand Total :		498.69	498.69	498.69	498.69	01

UnitBUA Table for Building :A (1)

FLOOR	Name	UnitBUA Type	UnitBUA Area	Carpent Area	No. of Rooms	No. of Tenement
GROUND FLOOR PLAN	SPLIT 1	FLAT	498.68	498.57	14	1
FIRST FLOOR PLAN	SPLIT 1	FLAT	0.00	0.00	14	0
SECOND FLOOR PLAN	SPLIT 1	FLAT	0.00	0.00	14	0
Total:			498.68	498.57	42	1

Building :A (1)

Floor Name	Total Built Up Area (Sq.mt.)	Proposed FAR Area (Sq.mt.) Res.	Total FAR Area (Sq.mt.)	Total Consumed Additional FAR Area (Sq.mt.)	Tnmt (No.)
Ground Floor	166.23	166.23	166.23	166.23	01
First Floor	166.23	166.23	166.23	166.23	00
Second Floor	166.23	166.23	166.23	166.23	00
Terrace Floor	0.00	0.00	0.00	0.00	00
Total :	498.69	498.69	498.69	498.69	01
Total Number of Same Buildings :	1				
Total :	498.69	498.69	498.69	498.69	01

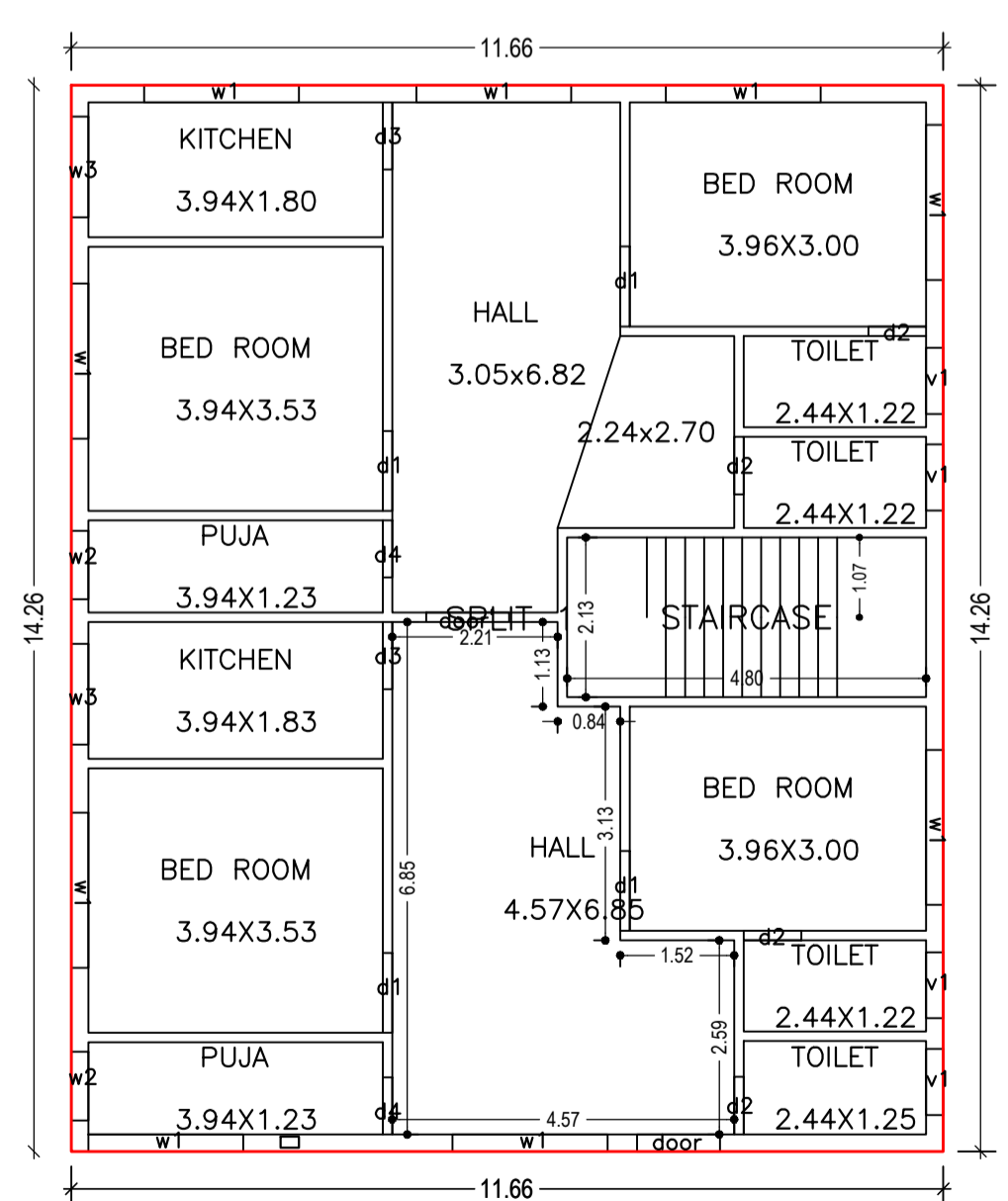

GROUND FLOOR PLAN (Proposed) (SCALE 1:100)

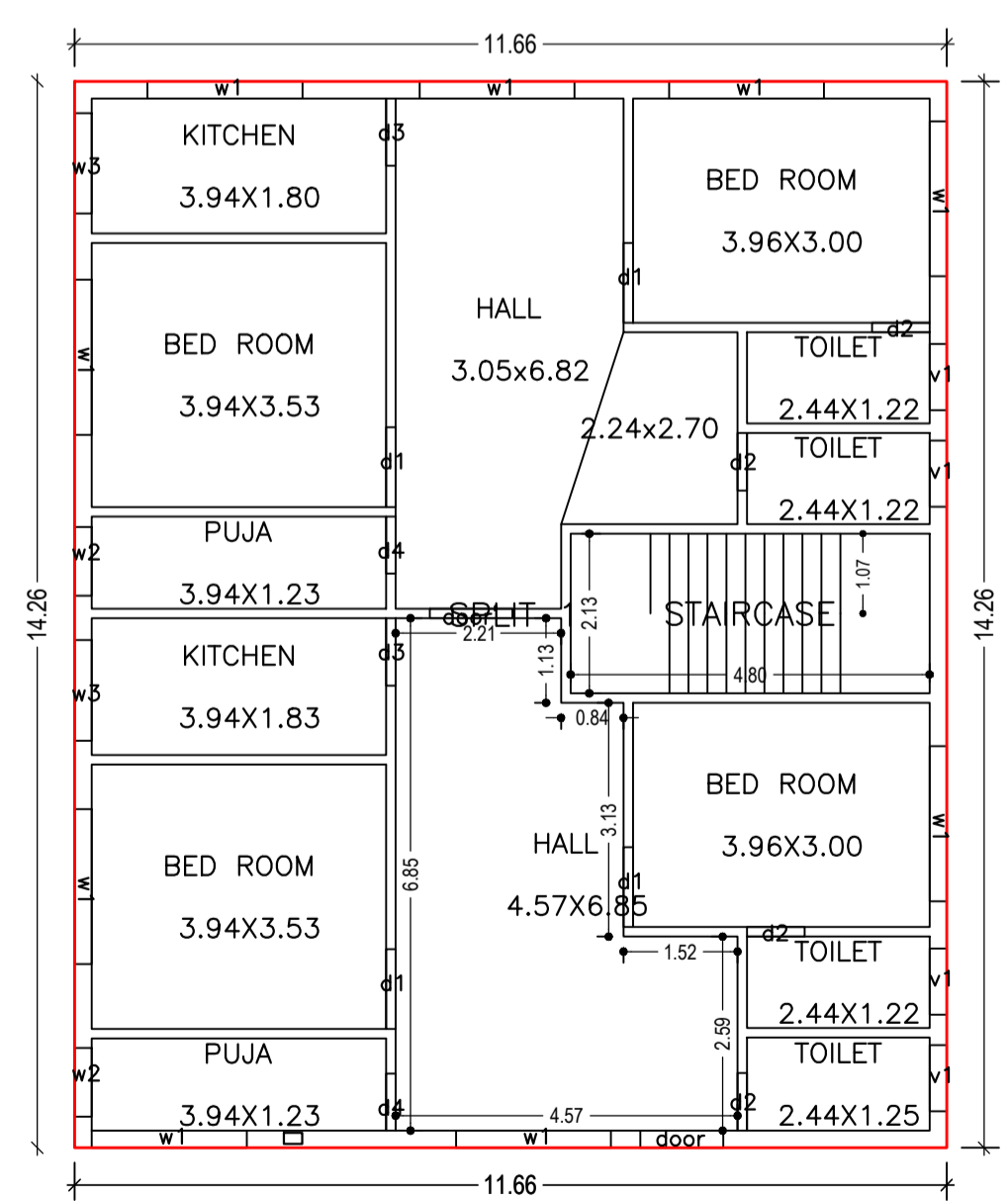

FIRST FLOOR PLAN (Proposed) (SCALE 1:100)

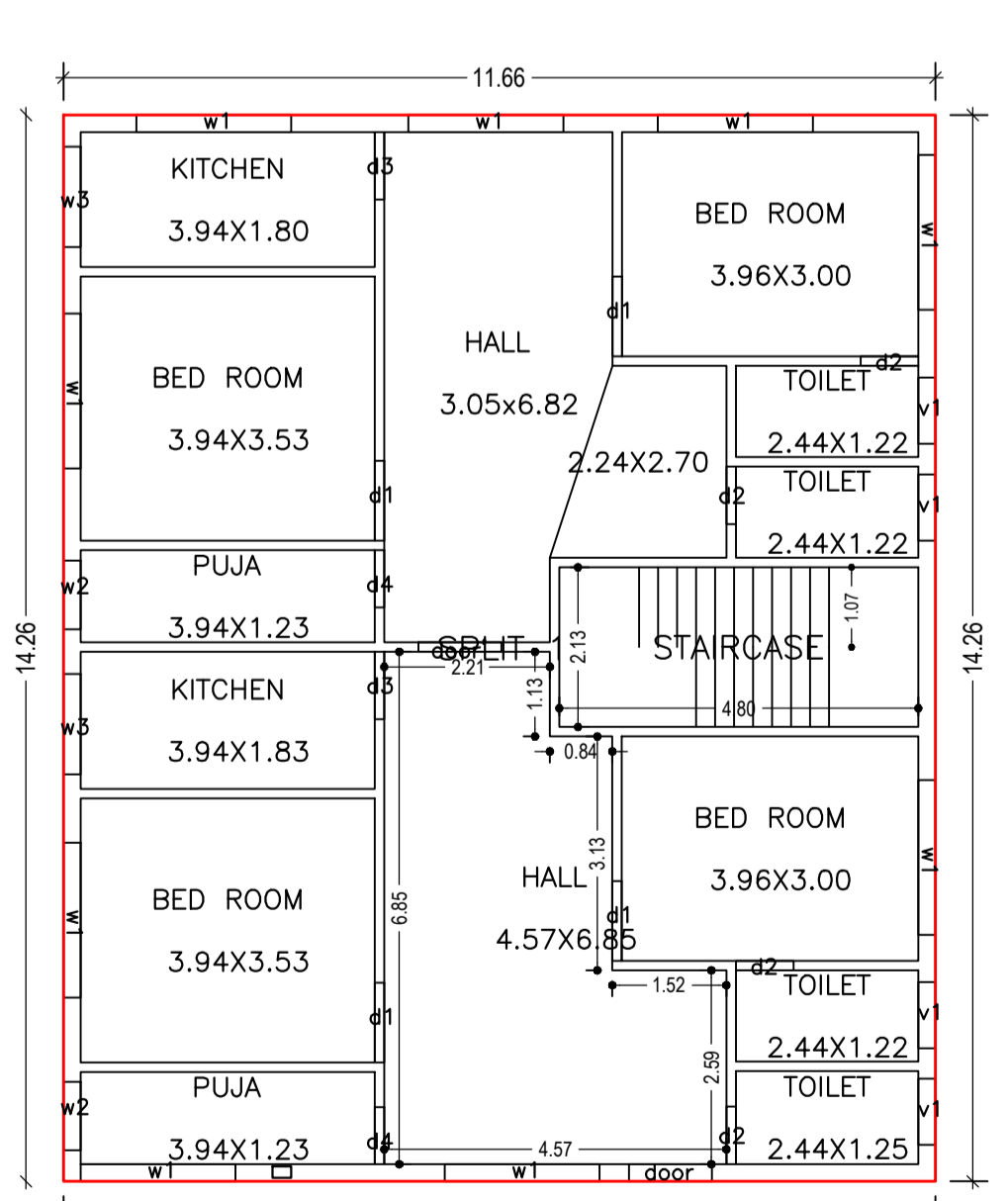

SECOND FLOOR PLAN (Proposed) (SCALE 1:100)

COLOR INDEX

PLOT BOUNDARY	Black
ABUTTING ROAD	Green
PROPOSED CONSTRUCTION	Red
COMMON PLOT	Yellow
ROAD WIDENING AREA	Blue
EXISTING (To be retained)	Light Blue
EXISTING (To be demolished)	Light Yellow

Buildingwise Floor FAR Details

Floor Name	Building Name A (1)		Total	
	Proposed Built Up Area (Sq.mt.)	Proposed FAR Area (Sq.mt.)	Total Proposed Built Up Area (Sq.mt.)	Total FAR Area (Sq.mt.)
Ground Floor	166.23	166.23	166.23	166.23
First Floor	166.23	166.23	166.23	166.23
Second Floor	166.23	166.23	166.23	166.23
Terrace Floor	0.00	0.00	0.00	0.00
Total :	498.69	498.69	498.69	498.69

SCHEDULE OF DOOR:

BUILDING NAME	NAME	LENGTH	HEIGHT	NOS
A (1)	d4	0.76	2.10	06
A (1)	d2	0.77	2.10	12
A (1)	d3	0.90	2.10	06
A (1)	d1	1.07	2.10	12
A (1)	door	1.11	2.10	03
A (1)	door'	1.11	2.10	03

SCHEDULE OF WINDOW/VENTILATION:

BUILDING NAME	NAME	LENGTH	HEIGHT	NOS
A (1)	w1	0.88	0.60	12
A (1)	w2	0.92	1.20	06
A (1)	w3	1.34	1.20	06
A (1)	w1	2.07	1.20	27

LTP NAME AND SIGNATURE SUSHIL KUMAR DMC/ENG/0005/2016	STRUCTURAL ENG'S NAME AND SIGNATURE	BUILDER NAME AND SIGNATURE	DIGITAL SIGNATURE
---	-------------------------------------	----------------------------	-------------------



Proposal Basic Information

Proposal File No.	DMC/BP/0232/W23/2021
Owner Name	Smt. Anju Sharma
Khata No	76 (NEW 271,91)
Plot No	42,43,44 ( NEW 17,67,18)
Village Name	Kolakusma
Use	Residential
SubUse	Bungalow/ Dwelling / Non Apartment

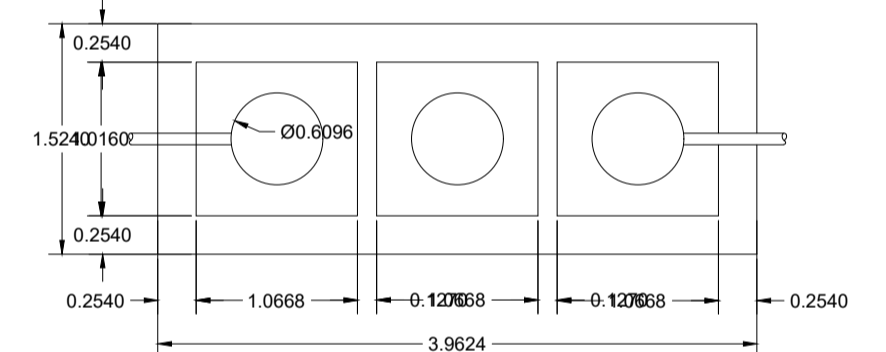
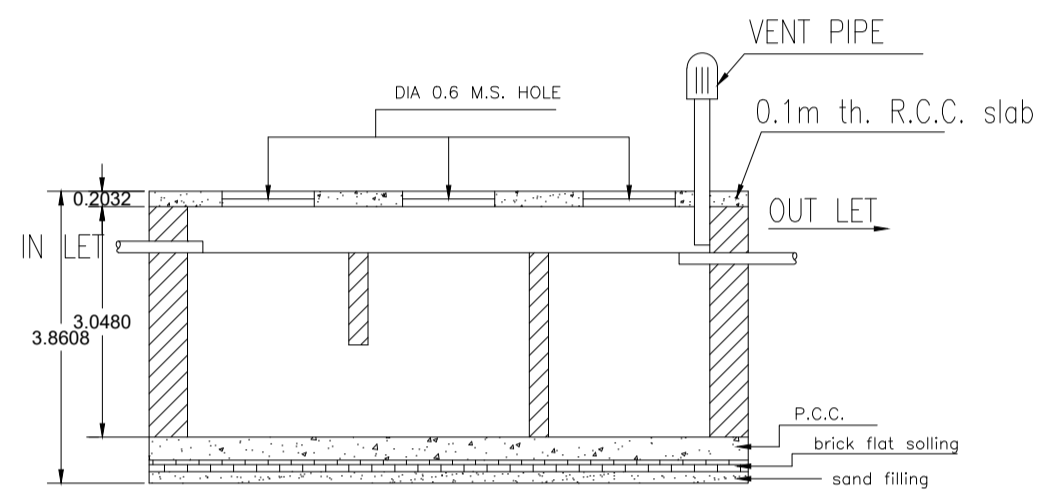
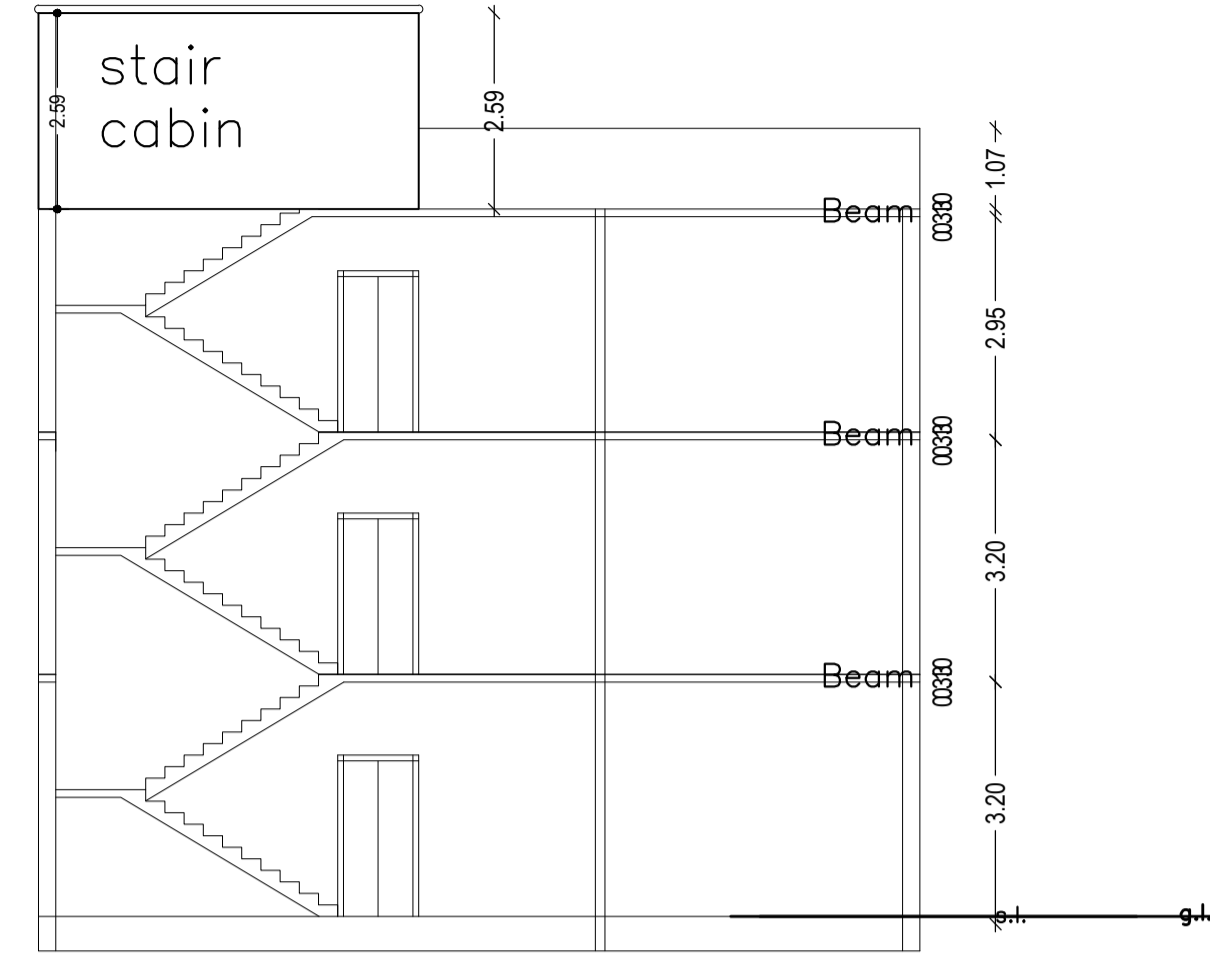
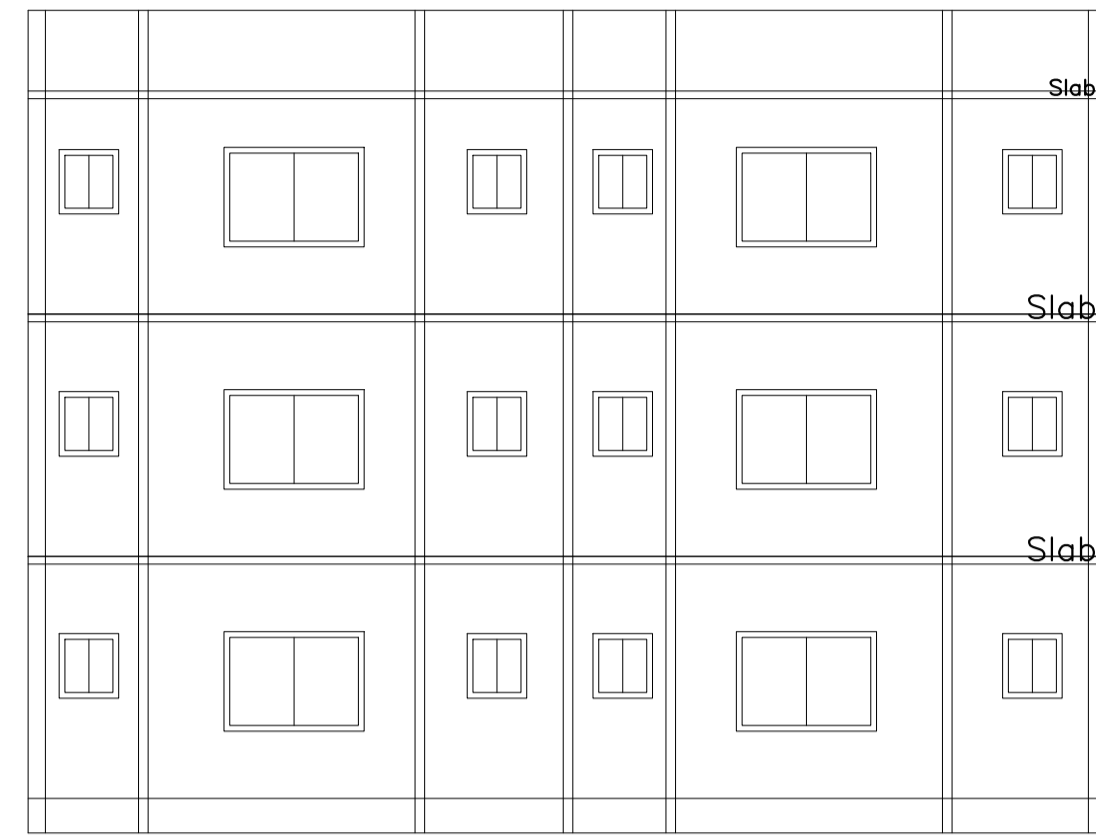
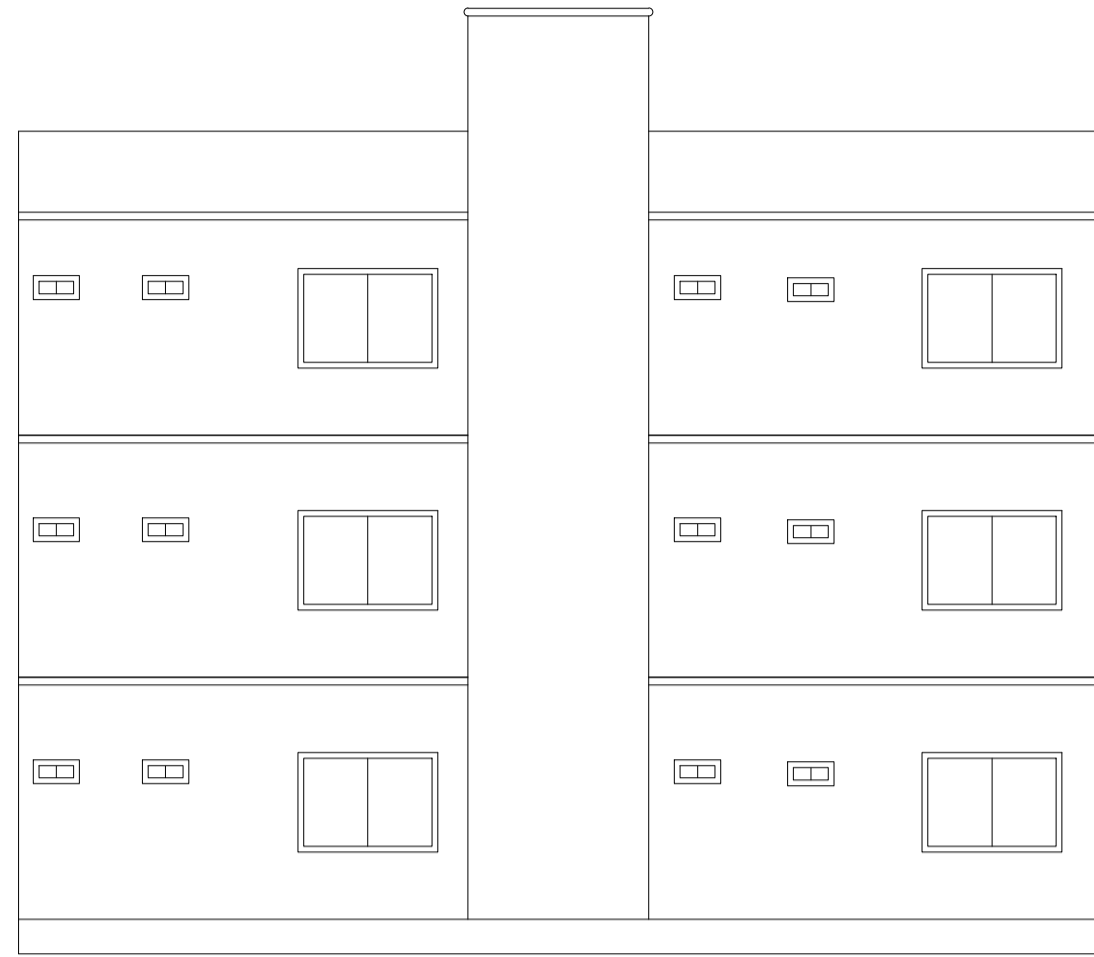
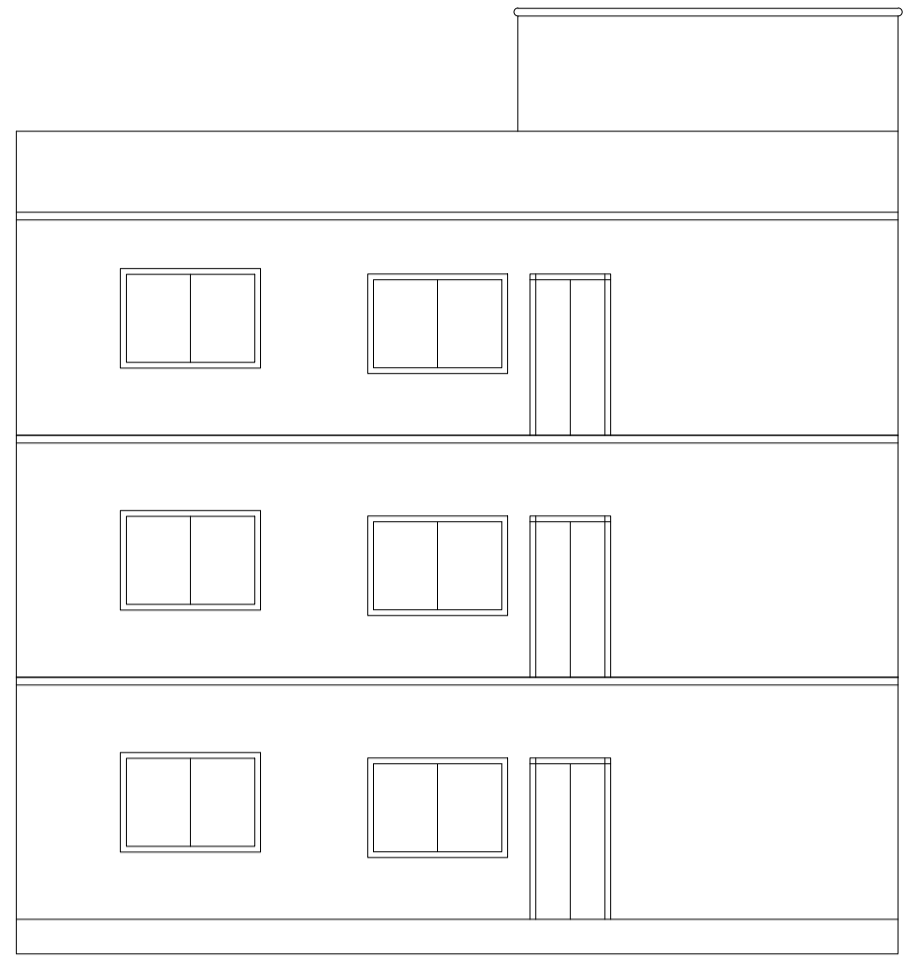
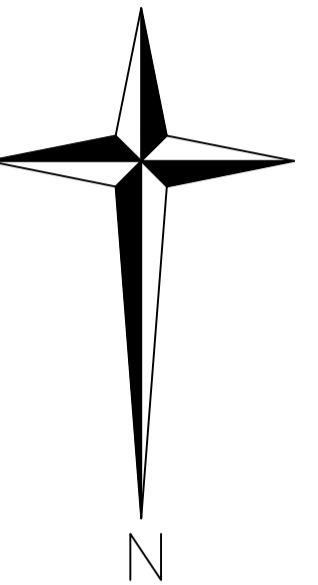

DETAILS OF SEPTIC TANK

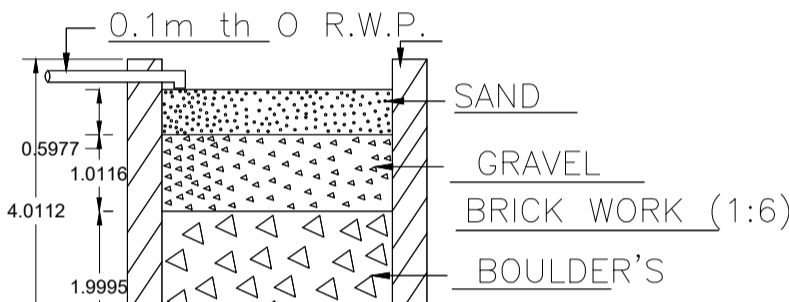
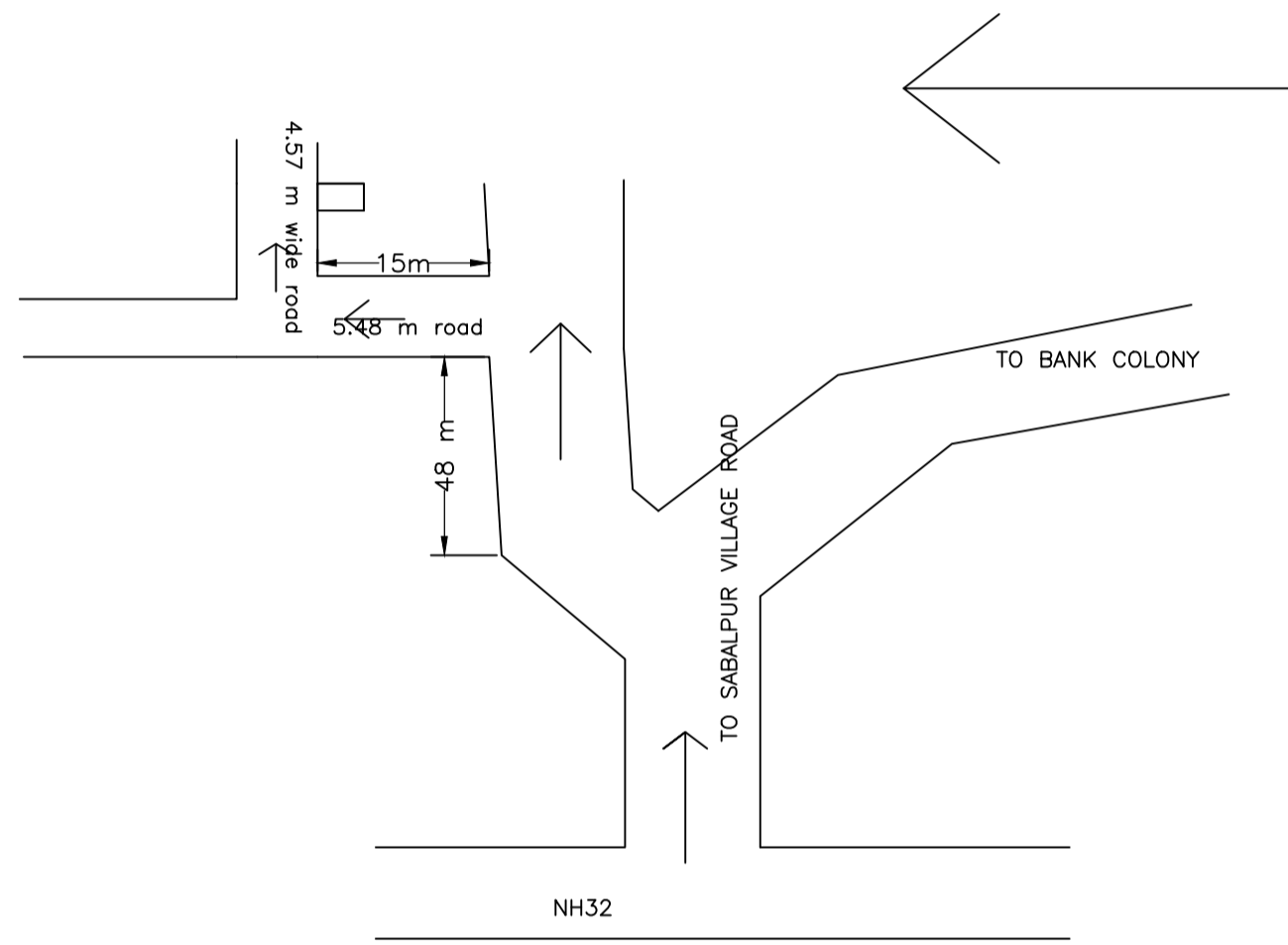

SECTION ON - AA

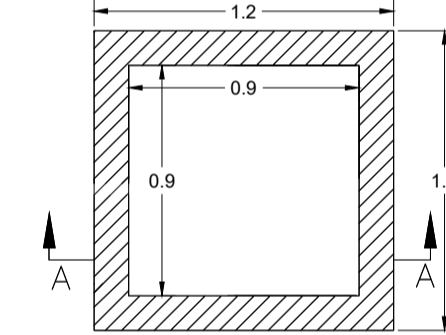

DETAIL'S OF WATER HARVESTING

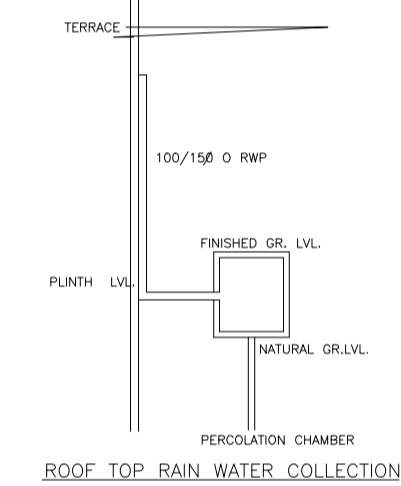

ROOF TOP RAIN WATER COLLECTION

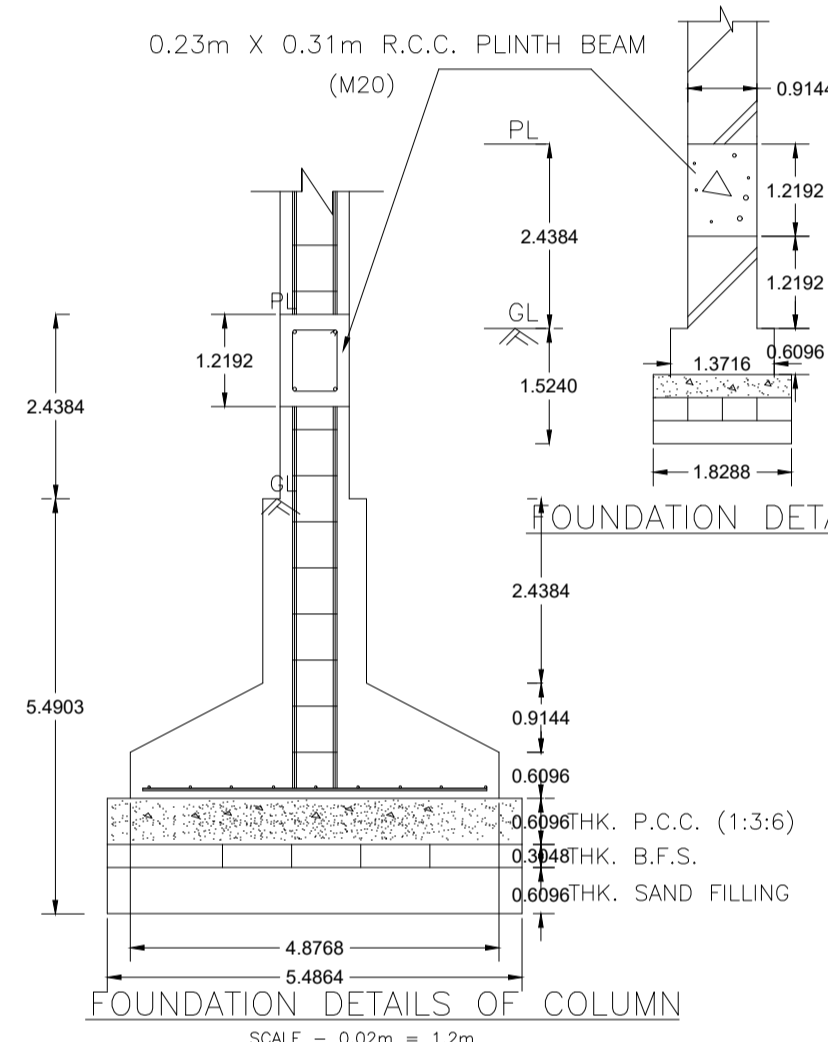

FOUNDATION DETAILS OF COLUMN

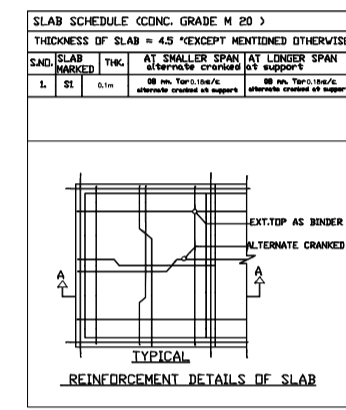

TYPICAL REINFORCEMENT DETAILS OF SLAB

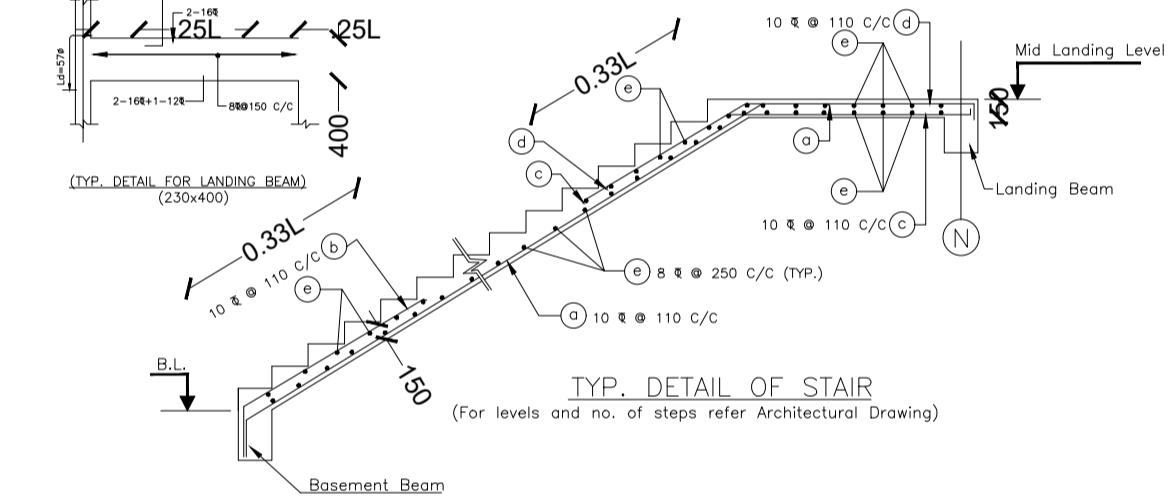

TYP. DETAIL OF STAIR

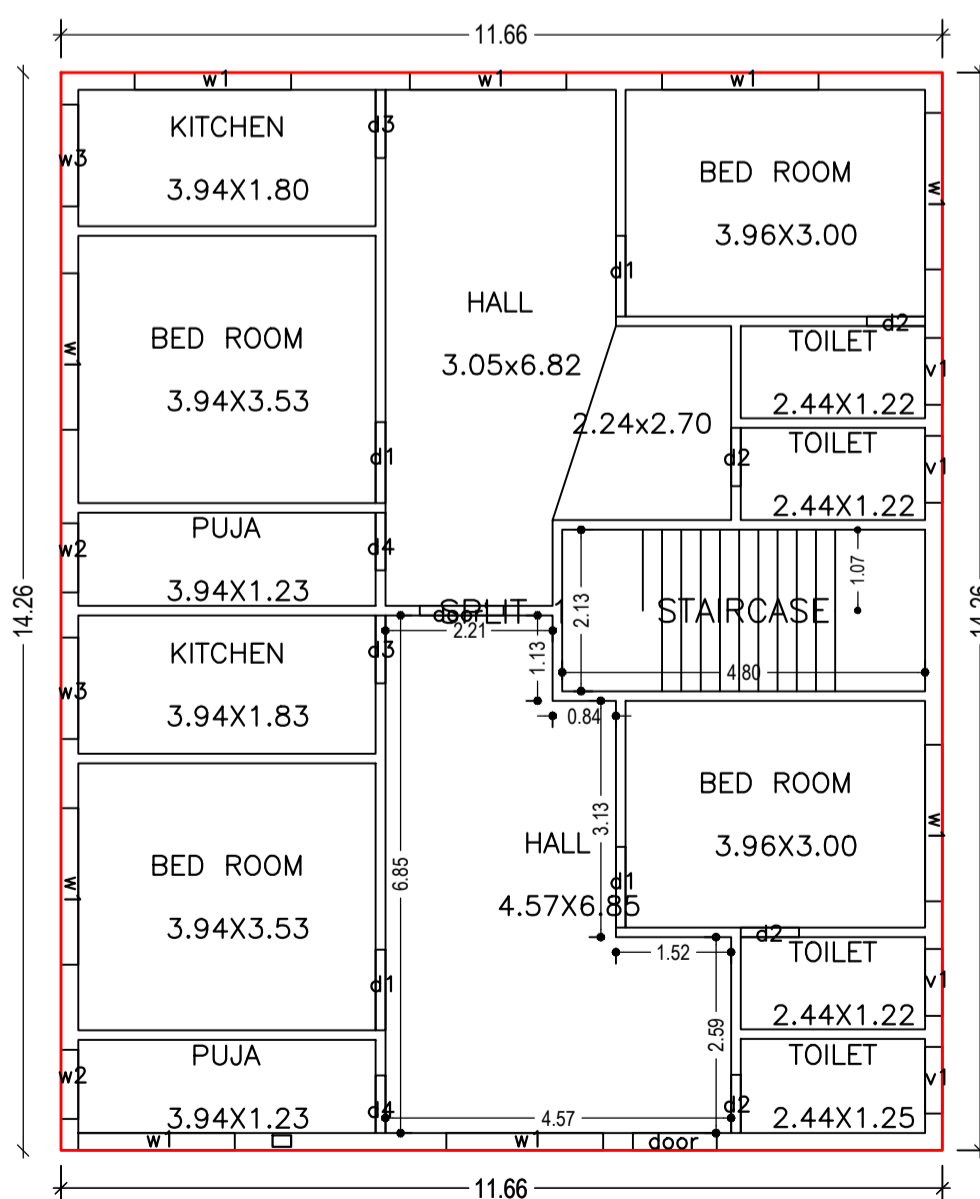

GROUND FLOOR PLAN (Proposed) (SCALE 1:100)

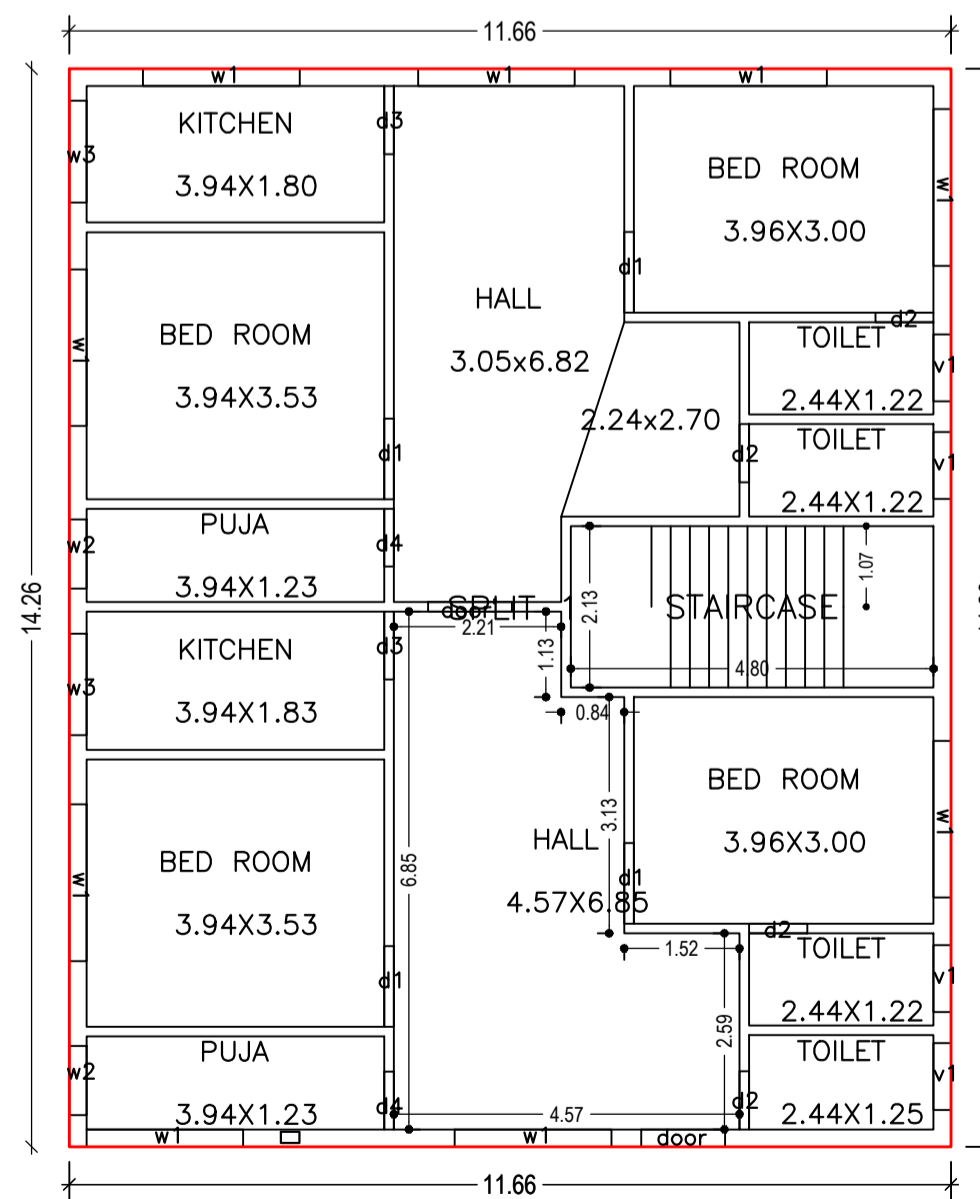

FIRST FLOOR PLAN (Proposed) (SCALE 1:100)

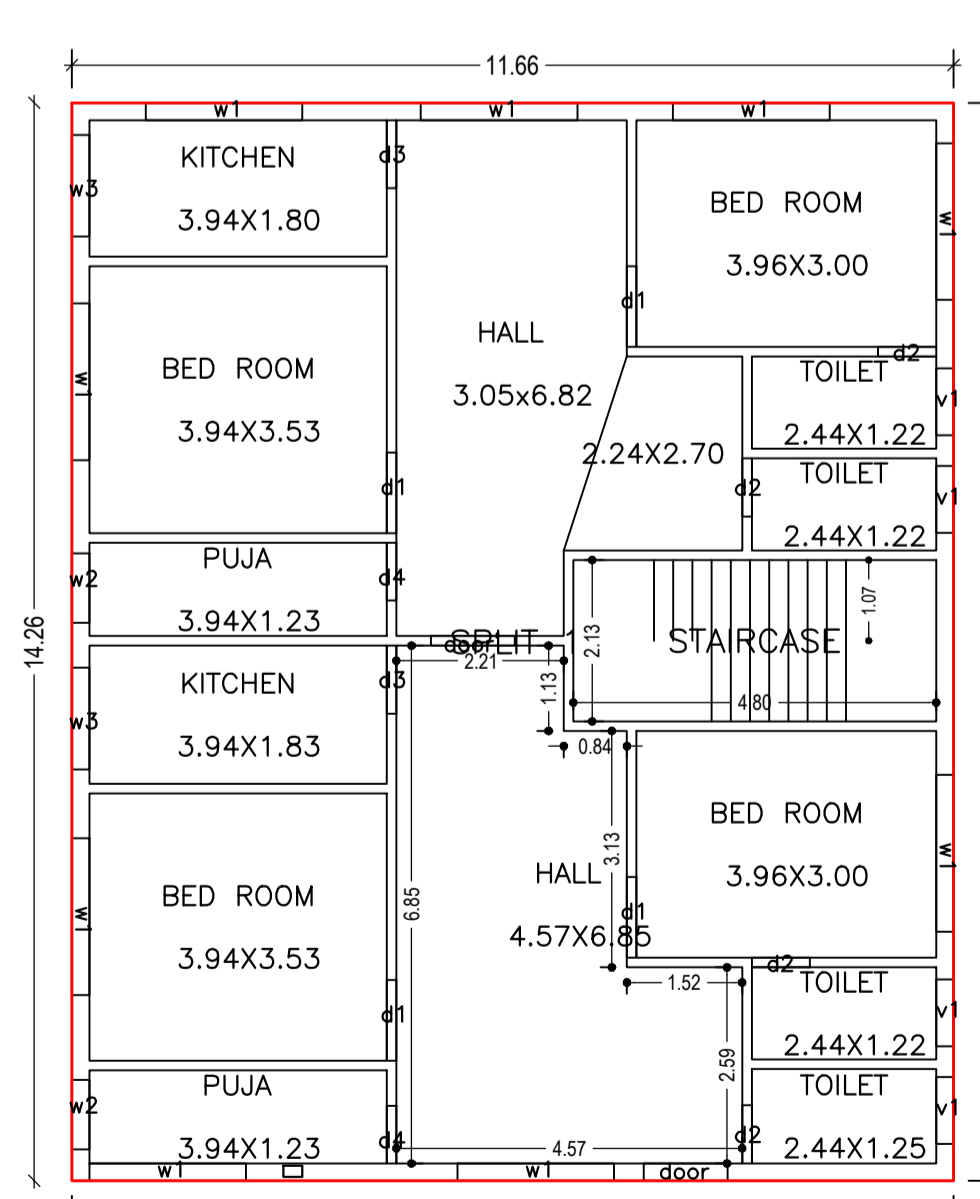

SECOND FLOOR PLAN (Proposed) (SCALE 1:100)

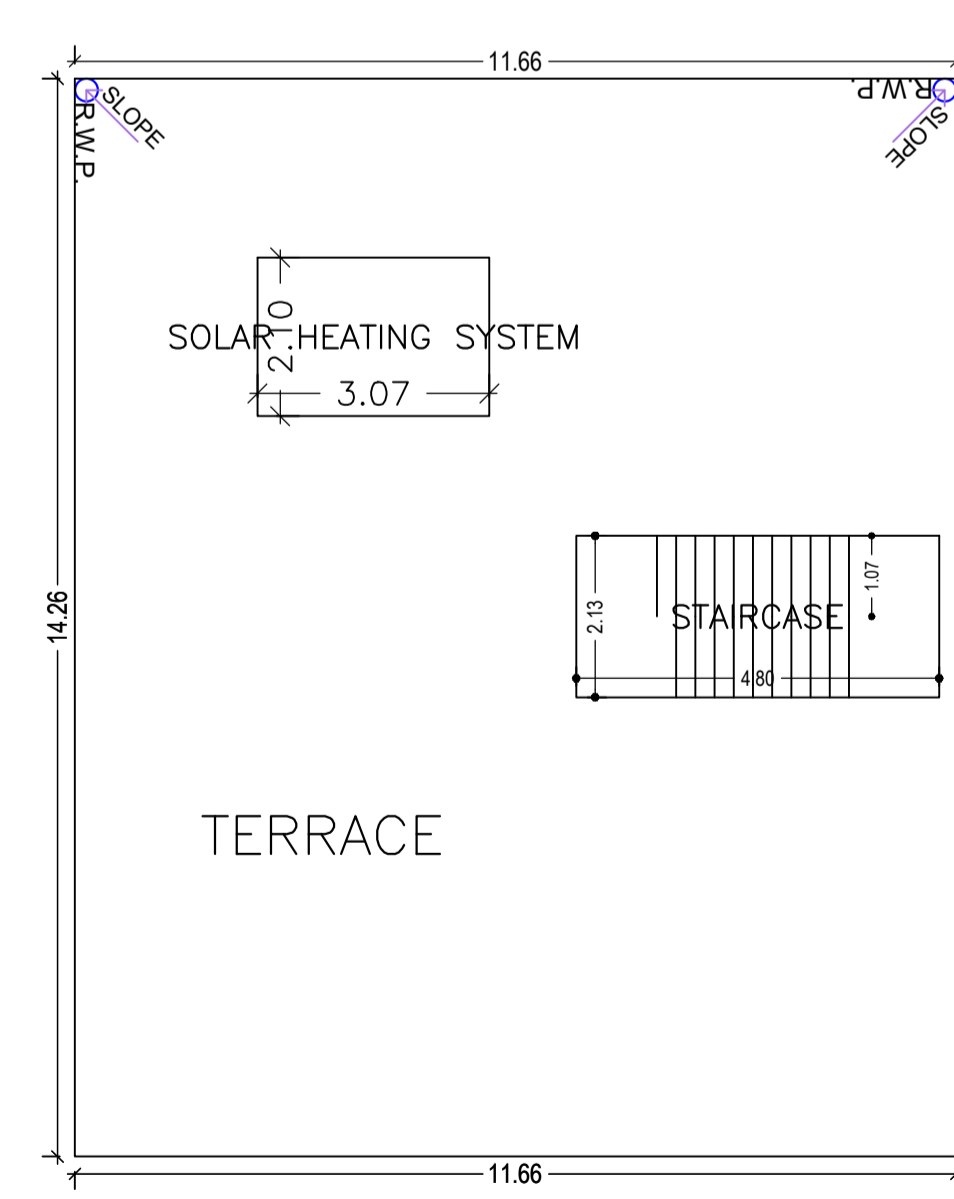

TERRACE FLOOR PLAN (SCALE 1:100)

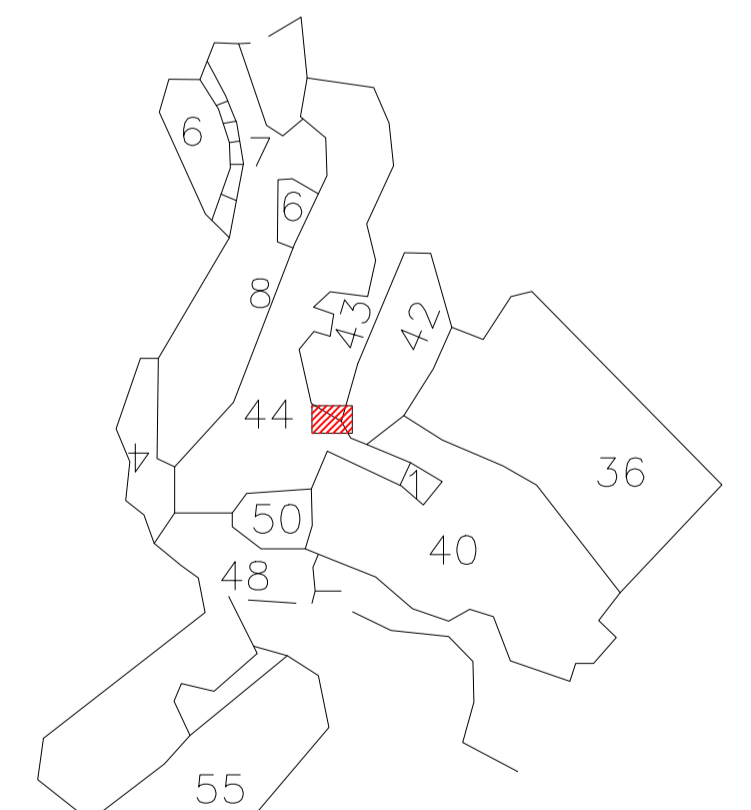

LTP NAME AND SIGNATURE SUSHIL KUMAR DMC/ENG/0005/2016	STRUCTURAL ENG'S NAME AND SIGNATURE	BUILDER NAME AND SIGNATURE	DIGITAL SIGNATURE
---	-------------------------------------	----------------------------	-------------------