

Proposal Basic Information

Proposal File No.	DMC/BP/0302/W20/2021
Owner Name	(1) SRI SUNIL KUMAR GUPTA (2) SRI SURAJ KUMAR GUPTA
Khata No	26 (O) 377 (N)
Plot No	70 (O) 105 (N)
Village Name	Bisampur
Use	Residential
SubUse	Bungalow/ Dwelling / Non Apartment

AREA STATEMENT	VERSION NO.: 1.0.62
DHANBAD MUNICIPAL CORPORATION	VERSION DATE: 16/10/2020
PROJECT DETAIL:	
Region: JHARKHAND URBAN LOCAL BODIES	Plot Use: Residential
District: DHANBAD	Plot SubUse: Bungalow/ Dwelling / Non Apartment
Authority: DHANBAD MUNICIPAL CORPORATION	Plot/Neary/Religious/Structure: NA
Inward No: DMC/BP/0302/W20/2021	Plot/SubPlot No: 70 (O) 105 (N)
Application Type: General Proposal	North: Plot No. - PART OF THIS PLOT (SUMAN ROY)
Project Type: Building Permission	South: Plot No. - PART OF THIS PLOT
Nature of Development: New	East: Plot No. - RAMADHAR PRASHAD
Location of Development Area: Old Area	West: Road Width - 4.26
AREA DETAILS:	
AREA OF PLOT (Minimum)	(A) 196.54 SQ.MT.
NET AREA OF PLOT (Gross Plot Area - Deduction from Gross Plot area)	(A-Deductions) 196.54
Deduction for Balance Plot Area (from Gross Plot Area)	
Common Plot Total	21.93
BALANCE AREA OF PLOT (Net Plot Area - Recreational/Amenity space)	(A-Deductions) 174.61
PLOT AREA FOR COVERAGE (Net Plot Area)	(A-Deductions) 196.54
Plot Area for FAR (Net Plot Area + Road Widening Area)	(A-Deductions) 196.54
COVERAGE CHECK	
Permissible Coverage area (70.00 %)	137.58
Proposed Coverage Area (45.74 %)	89.89
Total Prop. Coverage Area (45.74 %)	89.89
Balance coverage area (24.26 %)	47.69
FAR CHECK	
Perm. FAR Area (1.50)	294.81
Total Perm. FAR area	294.81
Residential FAR	179.78
Proposed FAR Area	179.78
Total Proposed FAR Area	179.78
Consumed FAR (Factor)	0.91
Balance FAR Area	115.03
BUILT UP AREA CHECK	
Total Proposed BuiltUp Area	179.78
ARCHITECT (Regd)	JITENDAR KUMAR
ENGINEER (Regd)	
SUPERVISOR (Regd)	
OWNER (Regd)	(1) SRI SUNIL KUMAR GUPTA (2) SRI SURAJ KUMAR GUPTA
DEVELOPMENT AUTHORITY	LOCAL BODY

COLOR INDEX	
PLOT BOUNDARY	Black
ABUTTING ROAD	Green
PROPOSED CONSTRUCTION	Red
COMMON PLOT	Yellow
ROAD WIDENING AREA	Blue
EXISTING (To be retained)	Light Blue
EXISTING (To be demolished)	White

Buildingwise Floor FAR Details					
Floor Name	Building Name (A/B)	Proposed Built Up Area (Sq.mt.)	Proposed FAR Area (Sq.mt.)	Total Proposed Built Up Area (Sq.mt.)	Total FAR Area (Sq.mt.)
Ground Floor	A (B)	89.89	89.89	89.89	89.89
First Floor	A (B)	89.89	89.89	89.89	89.89
Terrace Floor	A (B)	0.00	0.00	0.00	0.00
Total :		179.78	179.78	179.78	179.78

Building USE/SUBUSE Details			
Building Name	Building Use	Building SubUse	Building Structure
A (B)	Residential	Residential Bldg/Apartment	Non-Highrise

FAR & Tenement Details (Table 4c-1)						
Building	No. of Same Bldg	Total Built Up Area (Sq.mt.)	Proposed FAR Area (Sq.mt.)	Total FAR Area (Sq.mt.)	Total Consumed Additional FAR Area (Sq.mt.)	Trmt (No.)
A (B)	1	179.78	179.78	179.78	179.78	01
Grand Total :		179.78	179.78	179.78	179.78	01

UnitBUA Table for Building :A (B)						
FLOOR	Name	UnitBUA Type	UnitBUA Area	Carpet Area	No. of Rooms	No. of Tenement
GROUND FLOOR PLAN	SPLIT 1	FLAT	179.78	179.68	8	1
FIRST FLOOR PLAN	SPLIT 1	FLAT	0.00	0.00	9	0
Total:	-	-	179.78	179.68	17	1

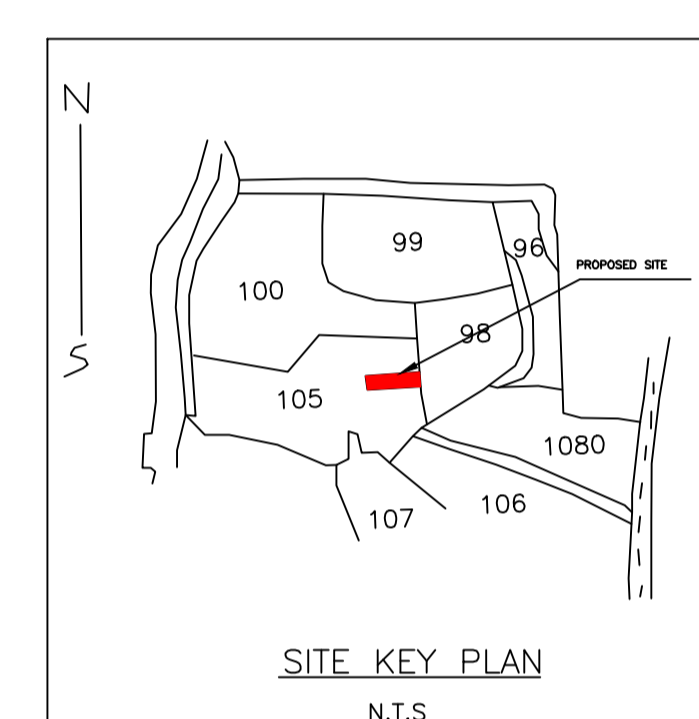
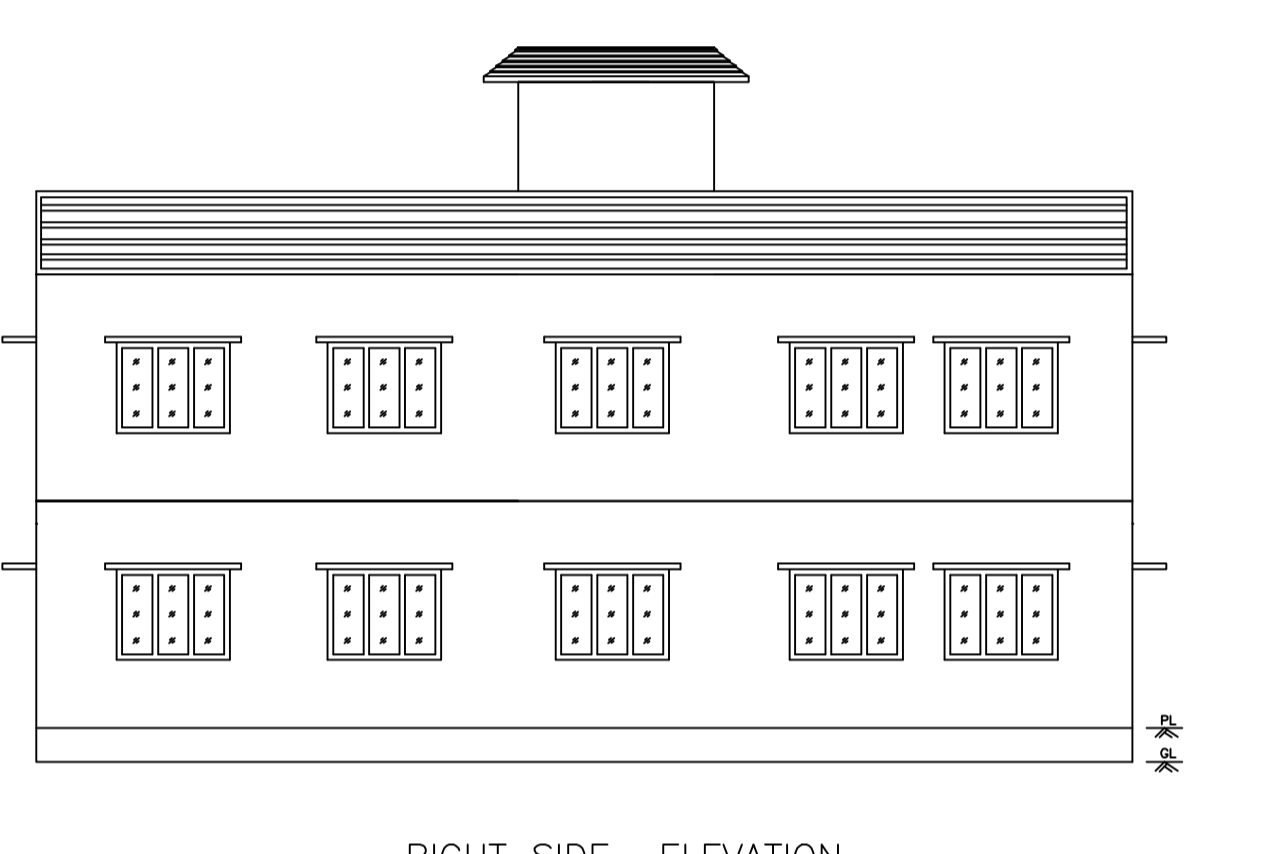
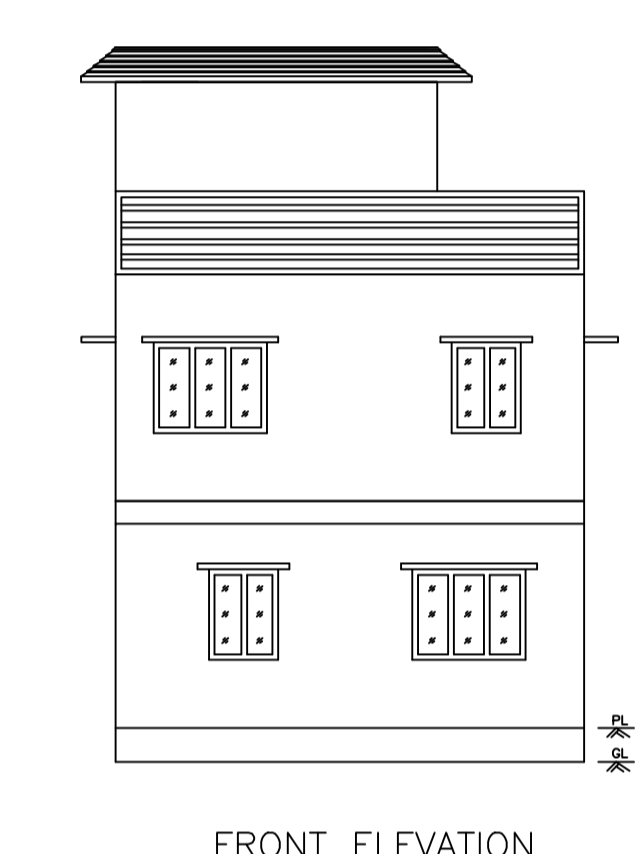
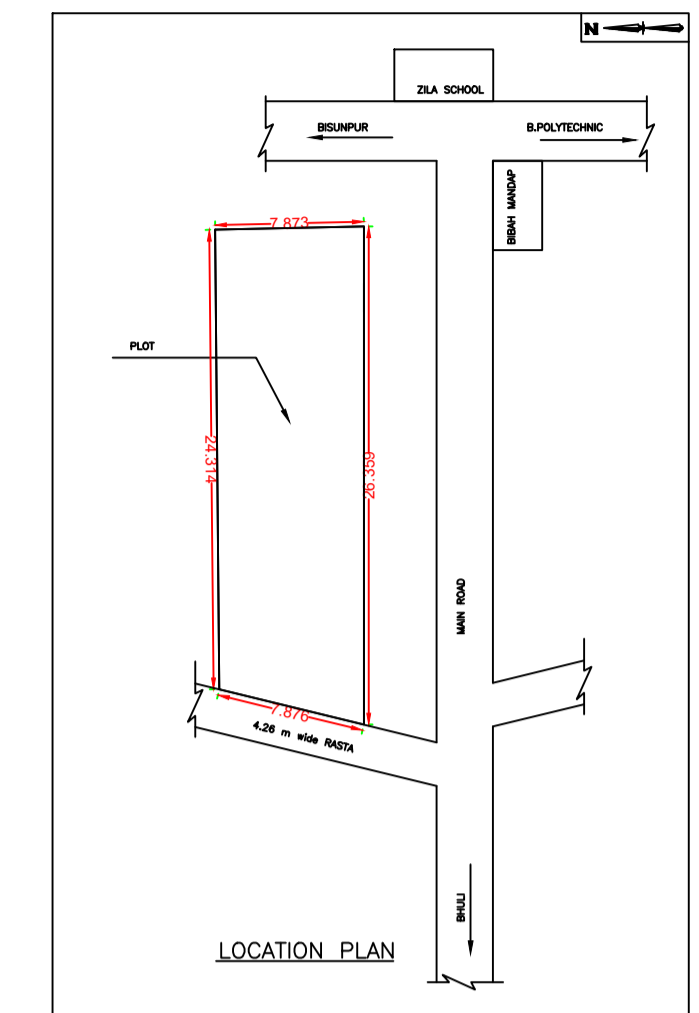
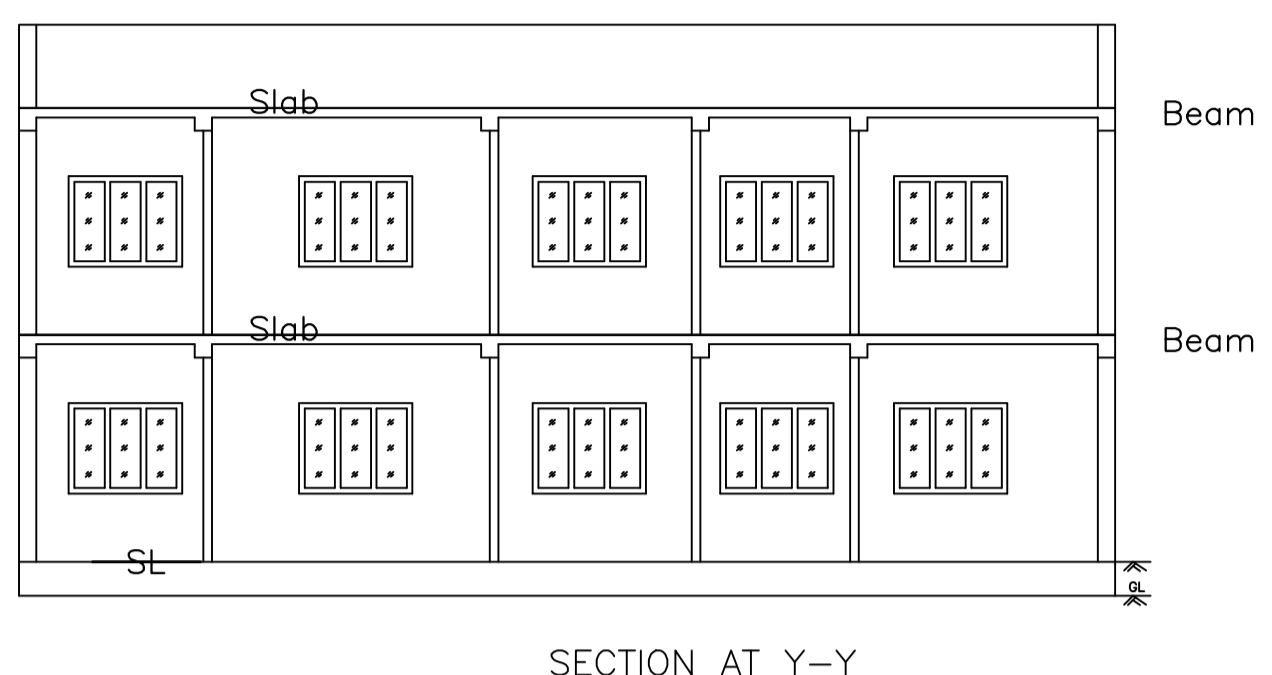
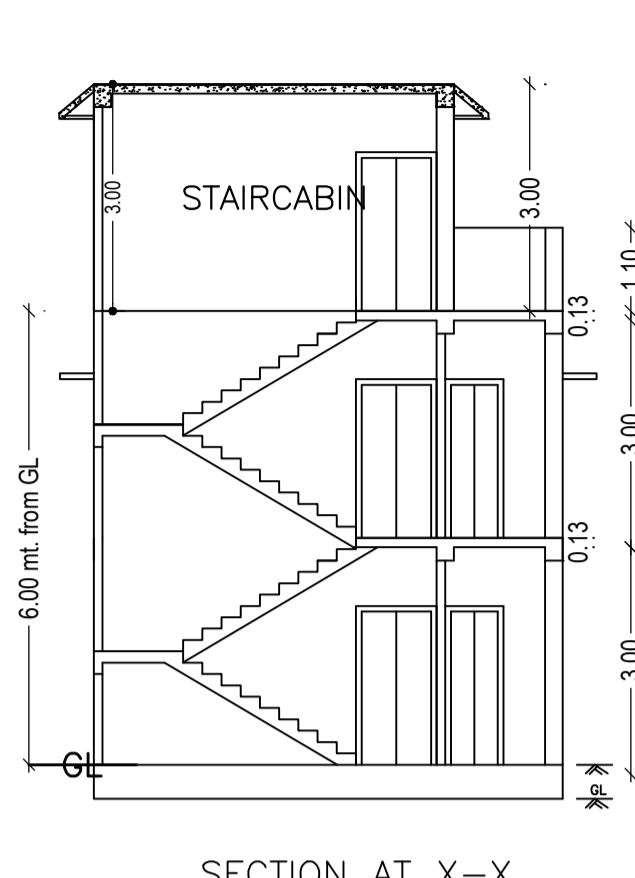
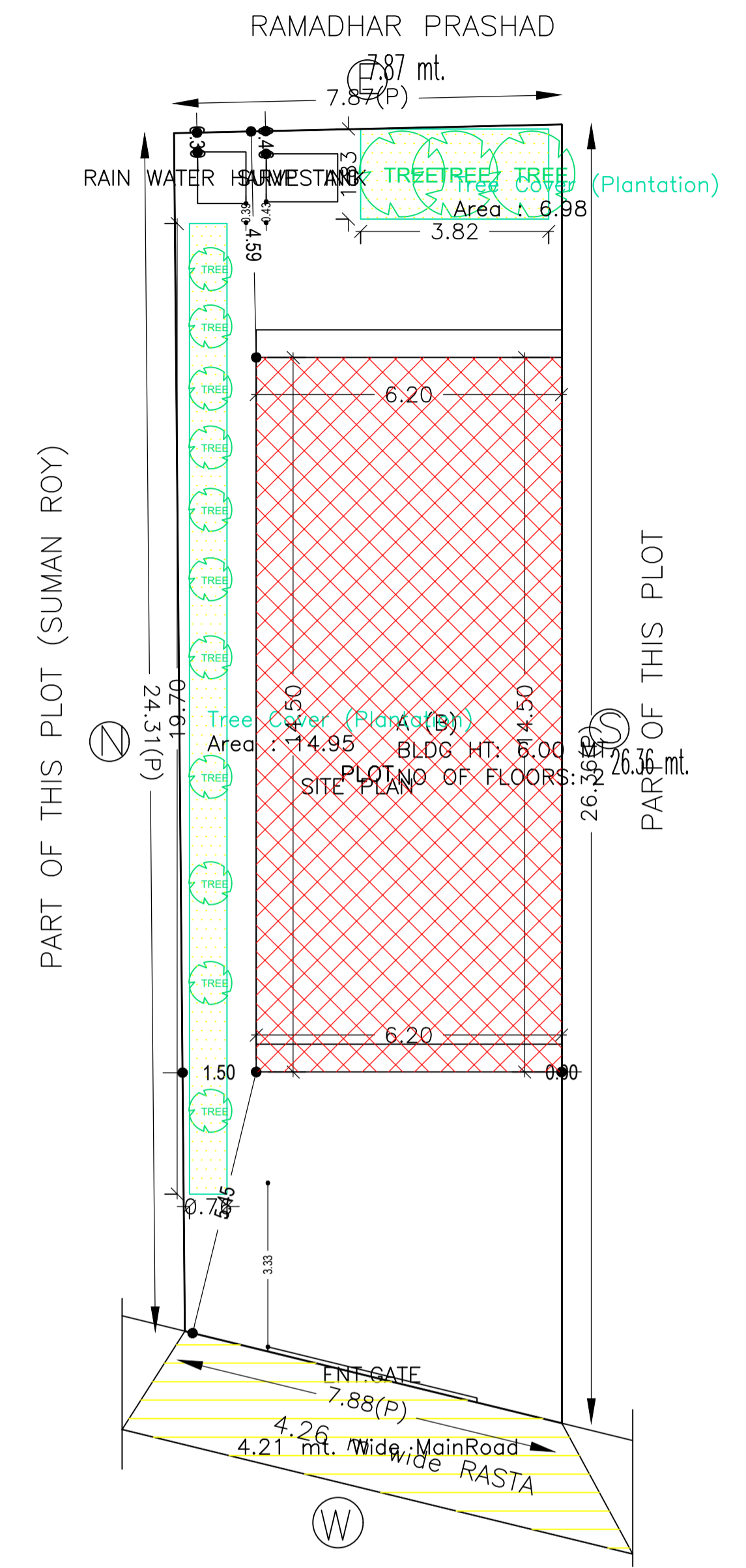

Building :A (B)					
Floor Name	Total Built Up Area (Sq.mt.)	Proposed FAR Area (Sq.mt.)	Total FAR Area (Sq.mt.)	Total Consumed Additional FAR Area (Sq.mt.)	Trmt (No.)
Ground Floor	89.89	89.89	89.89	89.89	01
First Floor	89.89	89.89	89.89	89.89	00
Terrace Floor	0.00	0.00	0.00	0.00	00
Total :	179.78	179.78	179.78	179.78	01
Total Number of Same Buildings	1				
Total :	179.78	179.78	179.78	179.78	01

SCHEDULE OF DOOR:				
BUILDING NAME	NAME	LENGTH	HEIGHT	NOS
A (B)	D	0.76	2.10	06
A (B)	D	0.91	2.10	02
A (B)	D	0.93	2.10	01
A (B)	D	1.05	2.10	01
A (B)	D	1.07	2.10	07

SCHEDULE OF WINDOW/VENTILATION:				
BUILDING NAME	NAME	LENGTH	HEIGHT	NOS
A (B)	W	0.85	1.20	01
A (B)	W	0.91	1.20	01
A (B)	W	1.10	1.20	02
A (B)	W	1.11	1.20	01
A (B)	W	1.12	1.20	01
A (B)	W	1.34	1.20	01
A (B)	W	1.52	1.20	09
A (B)	W	1.60	1.20	01
A (B)	W	1.66	1.20	01
A (B)	W	1.76	1.20	01
A (B)	W	1.77	1.20	01
A (B)	W	2.37	1.20	01
A (B)	W	2.49	1.20	01
A (B)	W	2.87	1.20	02
A (B)	W	2.97	1.20	02
A (B)	W	2.99	1.20	01

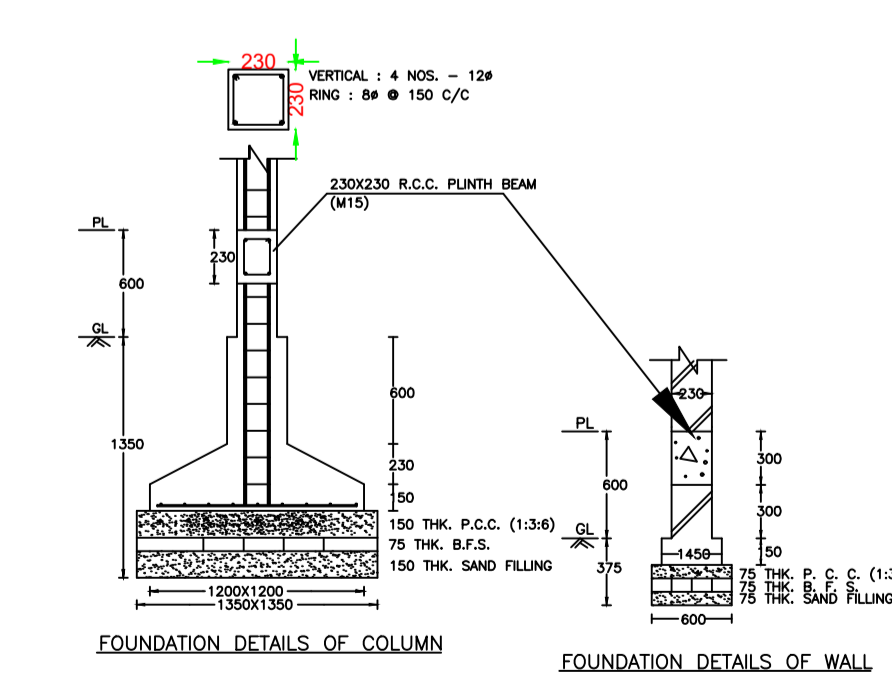
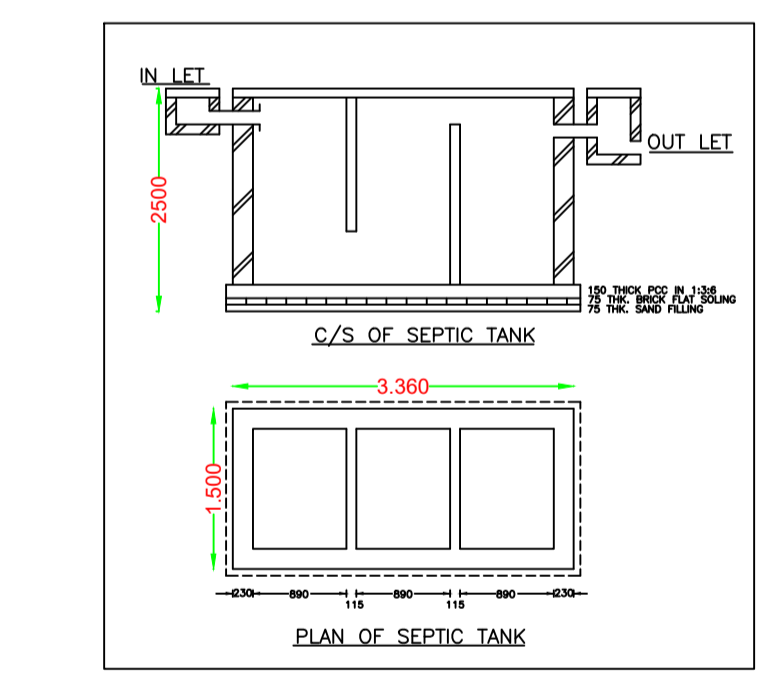
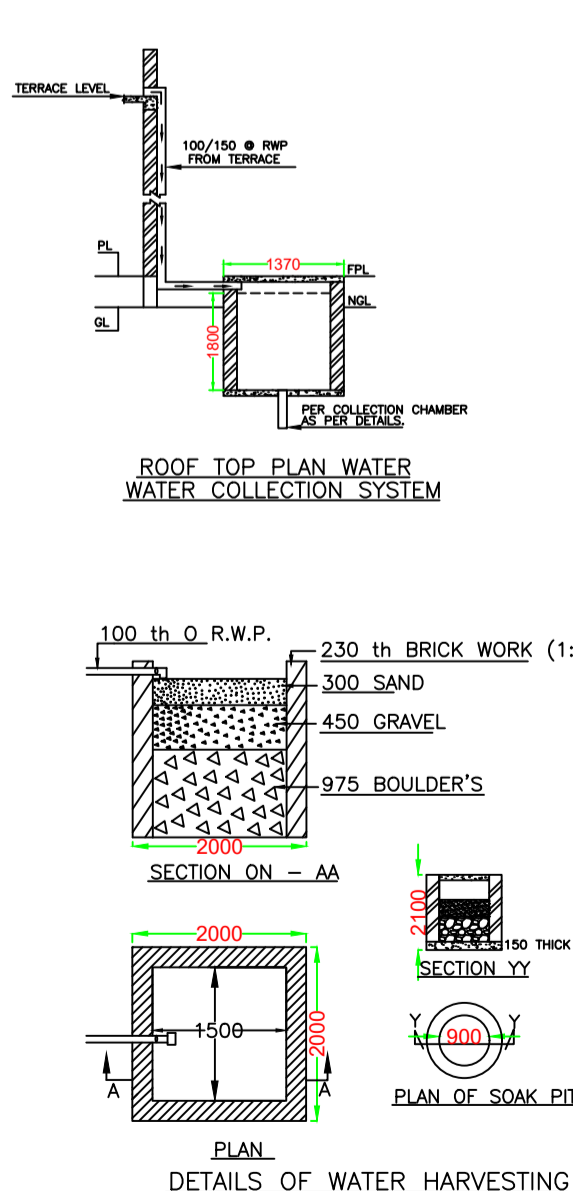
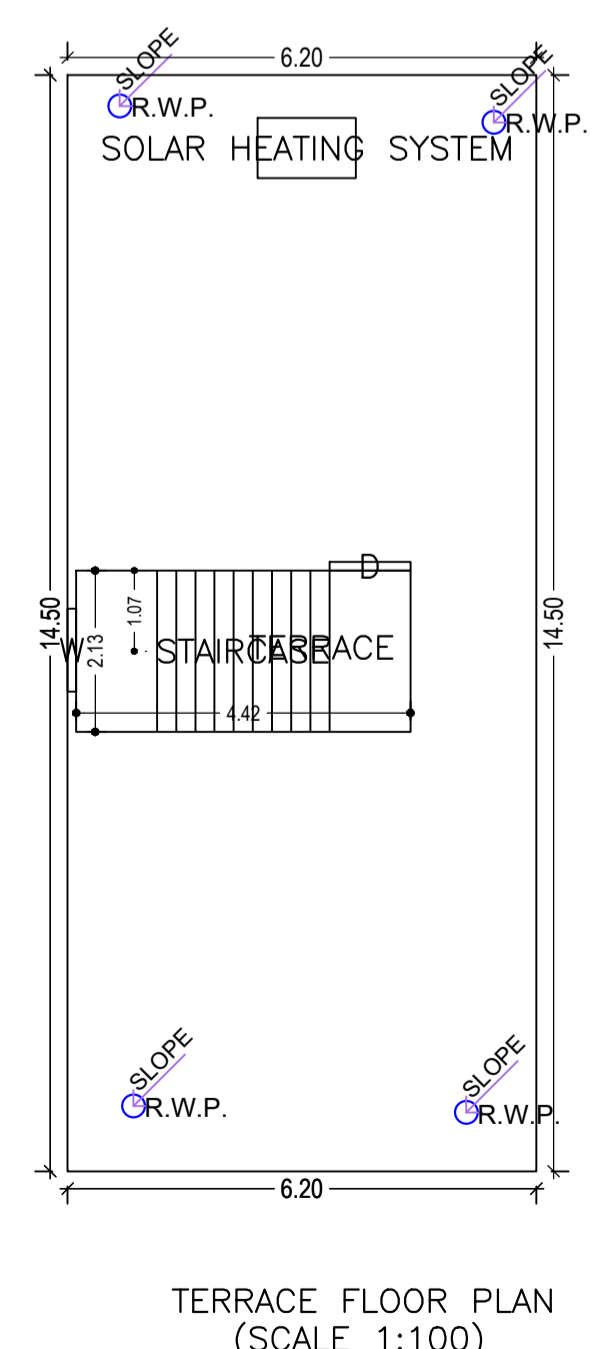
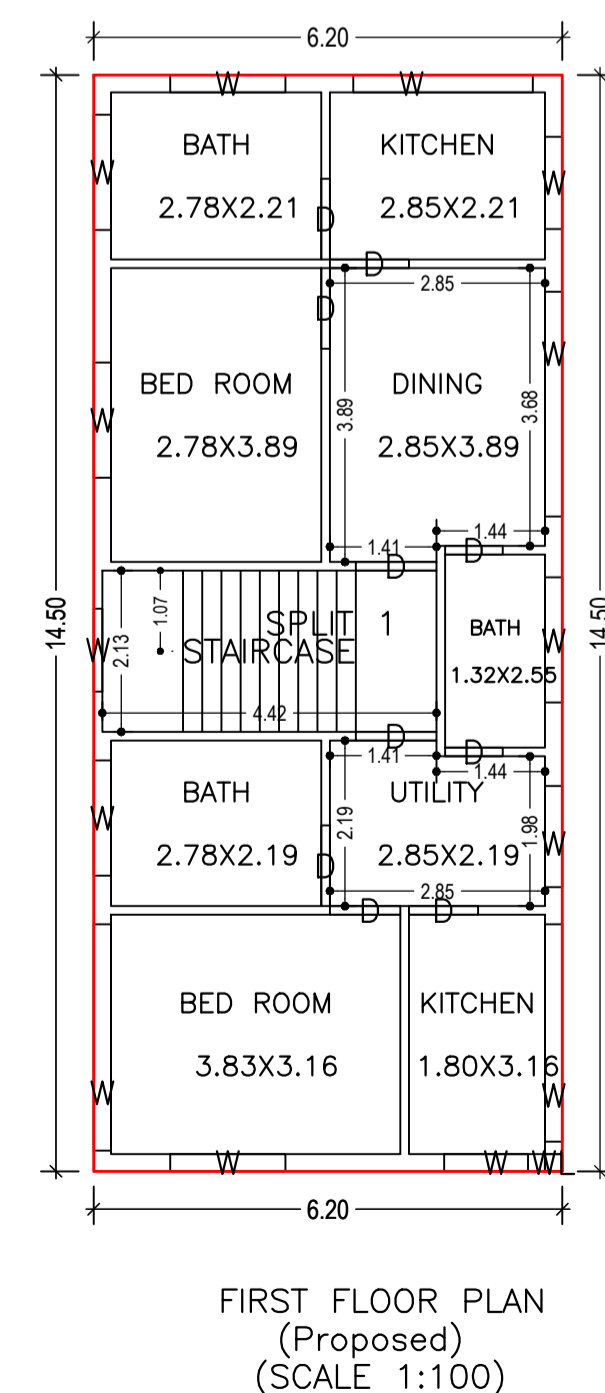
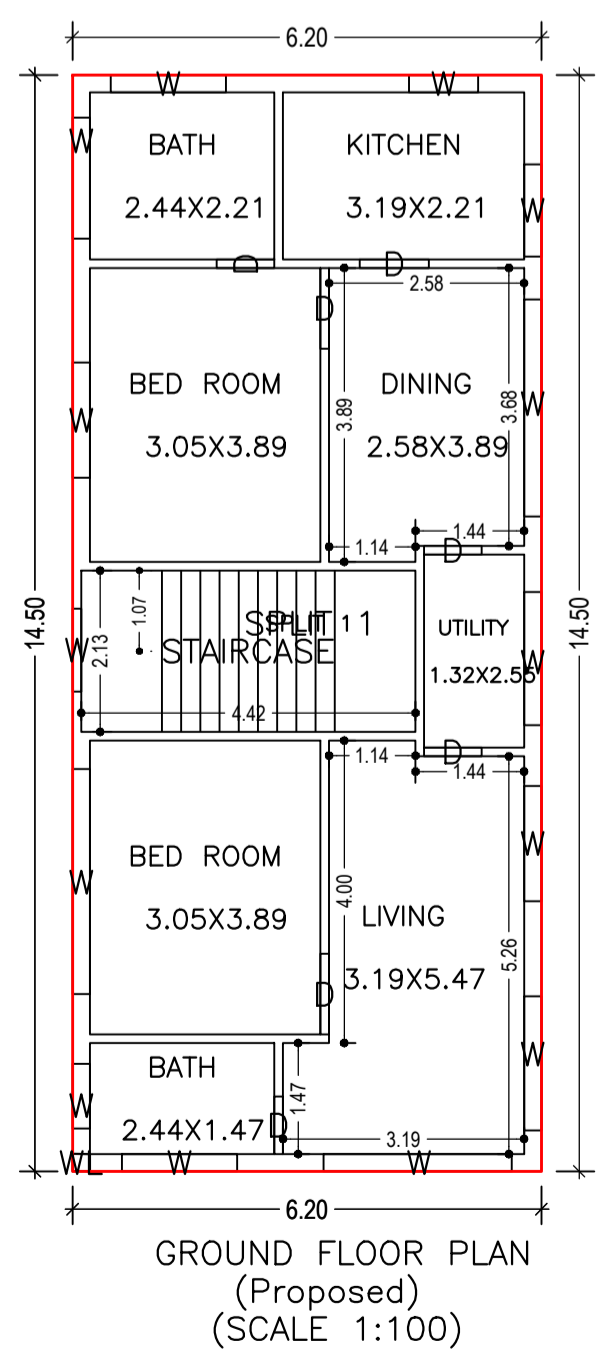

LTP NAME AND SIGNATURE	STRUCTURAL ENG'S NAME AND SIGNATURE	BUILDER NAME AND SIGNATURE	DIGITAL SIGNATURE
JITENDAR KUMAR DMC/DFTMN/006/2018			