

Project Title :SMT .INDU DEVI

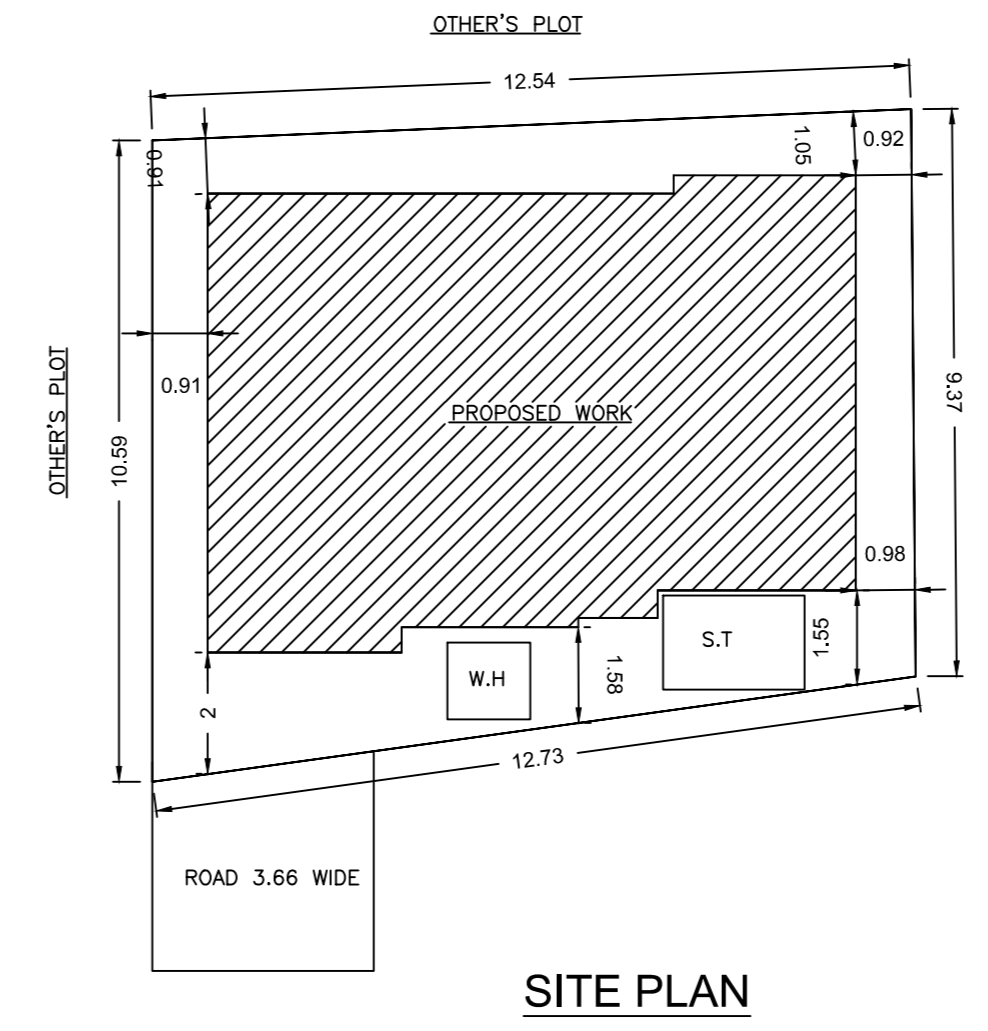
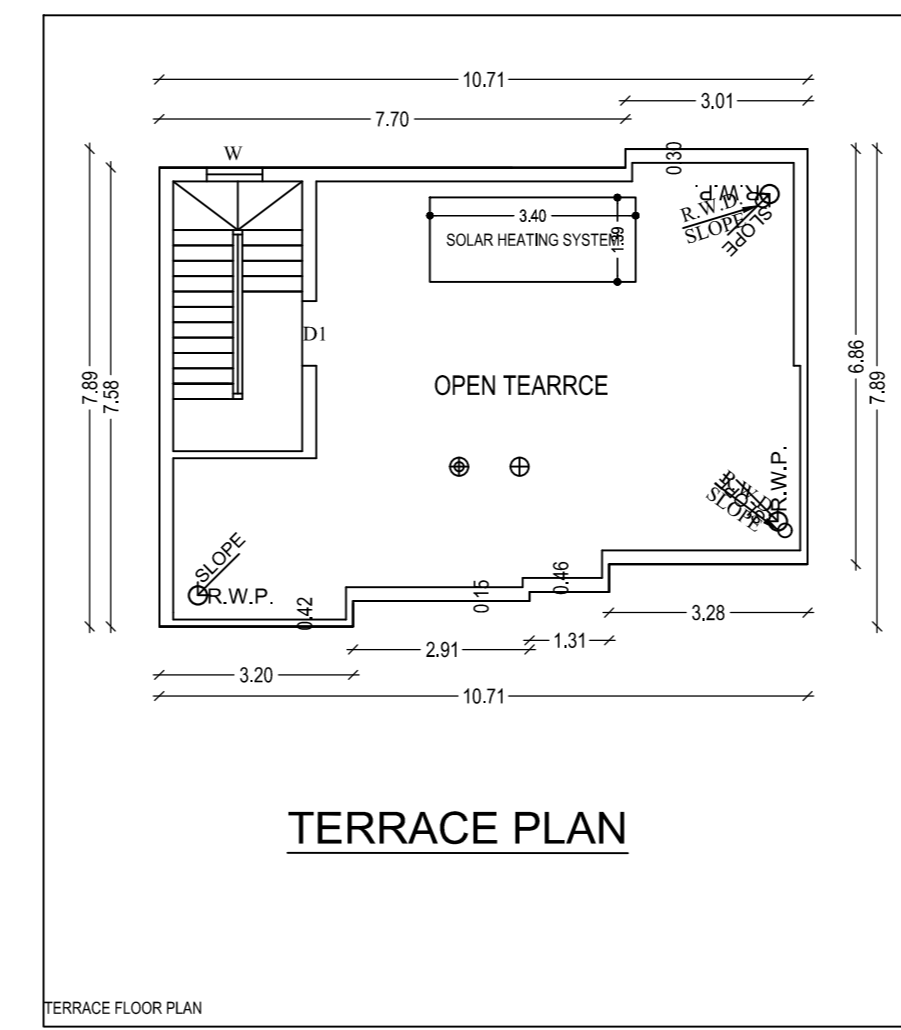
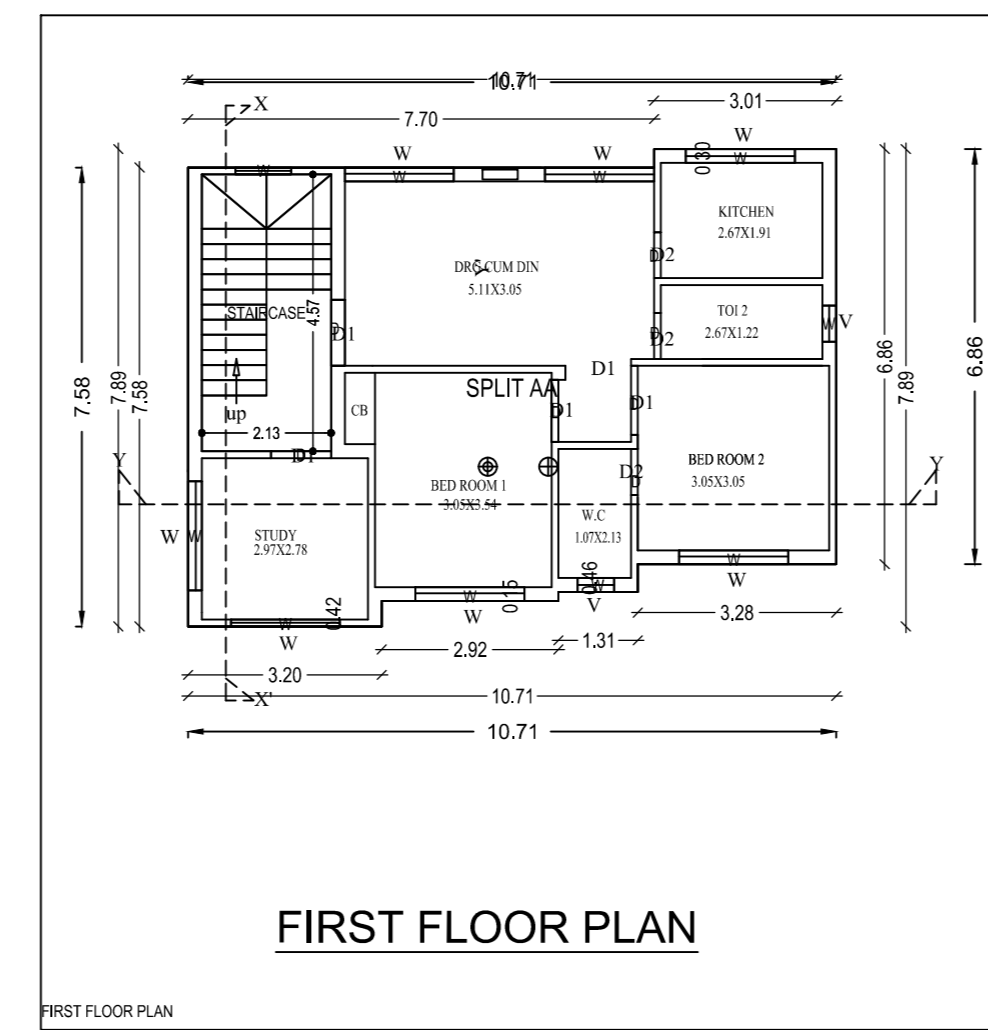
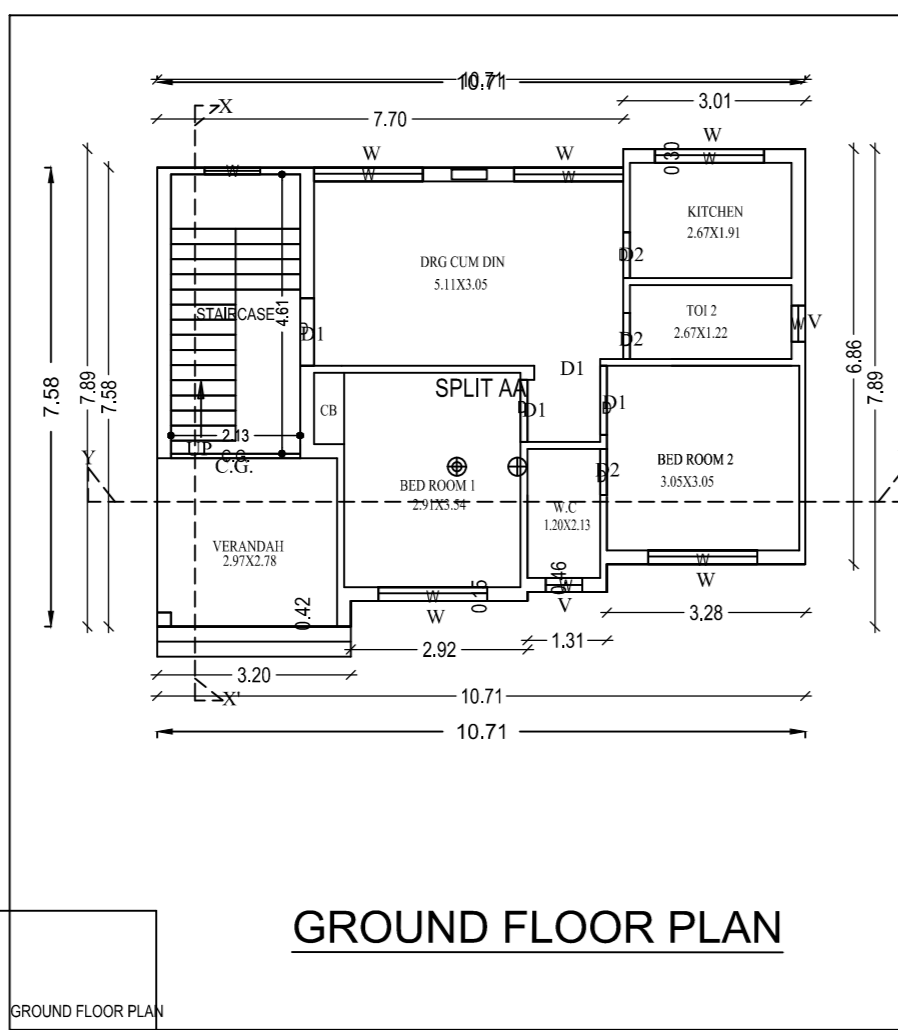
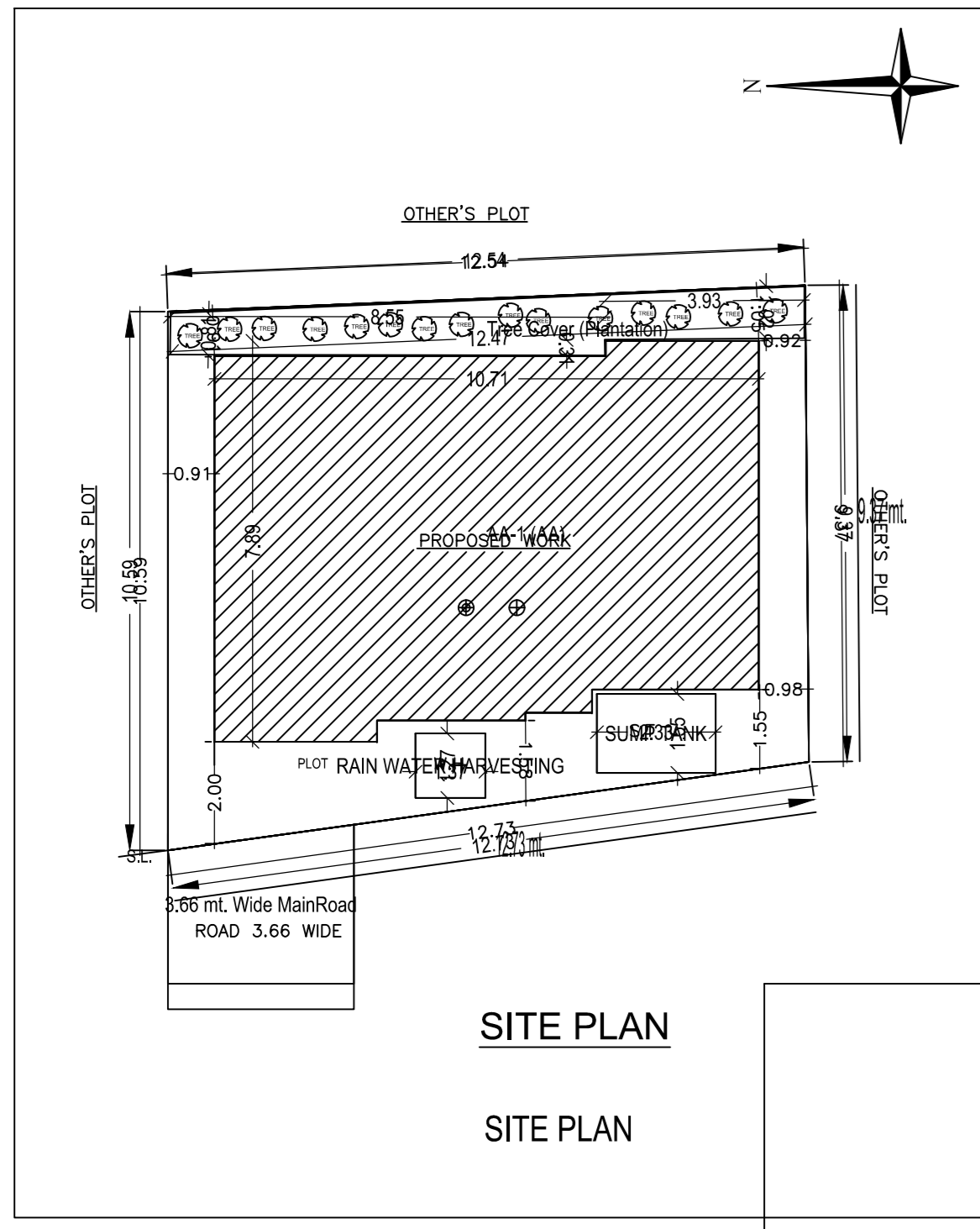
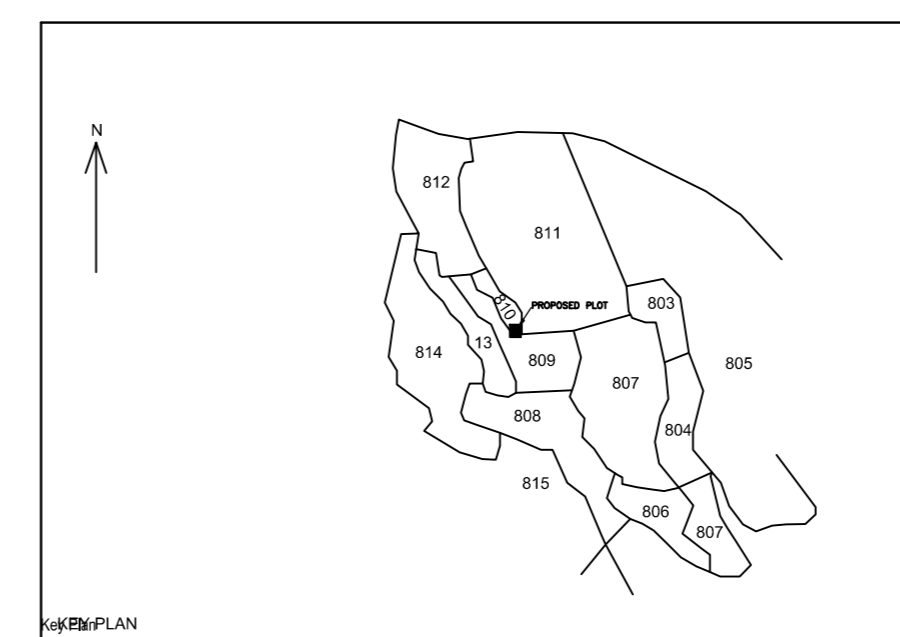
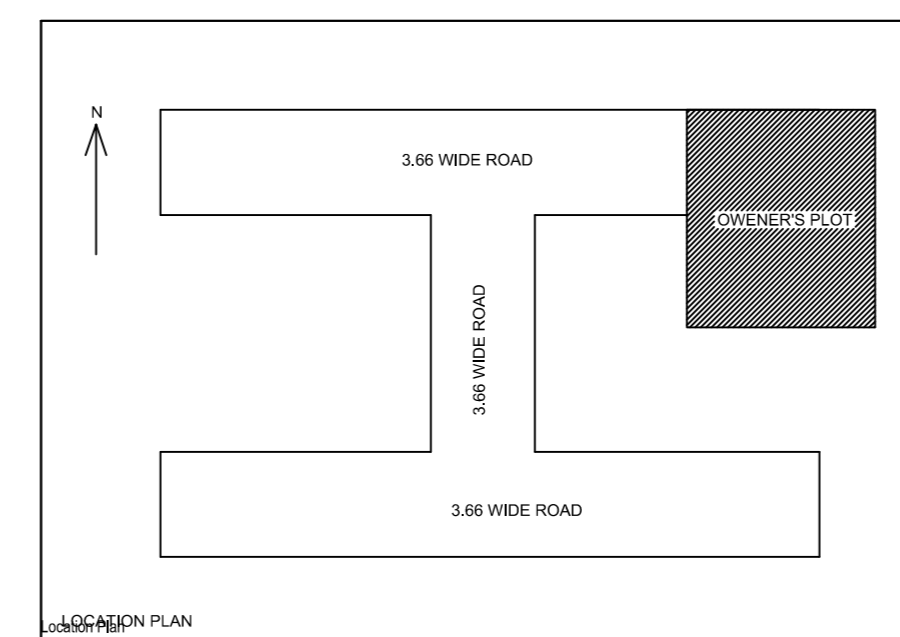
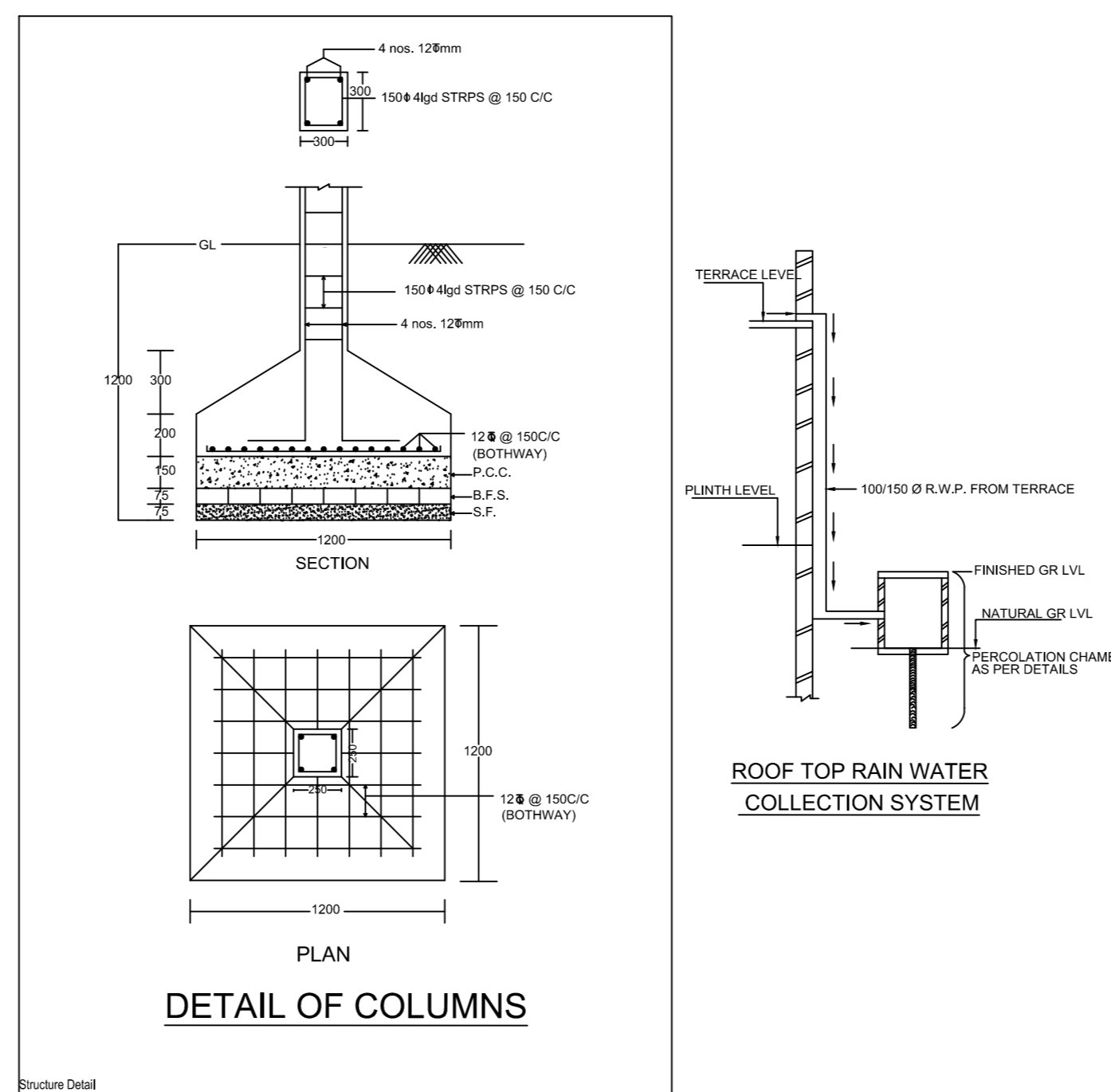
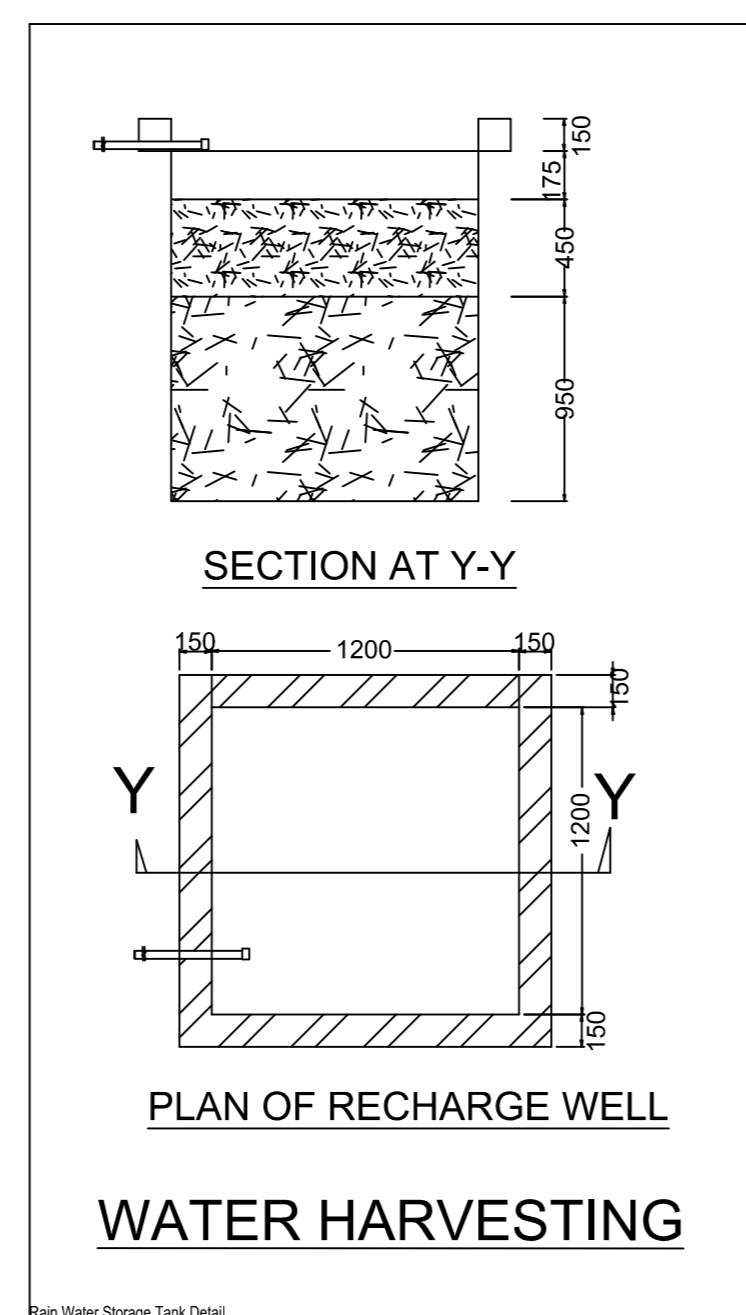
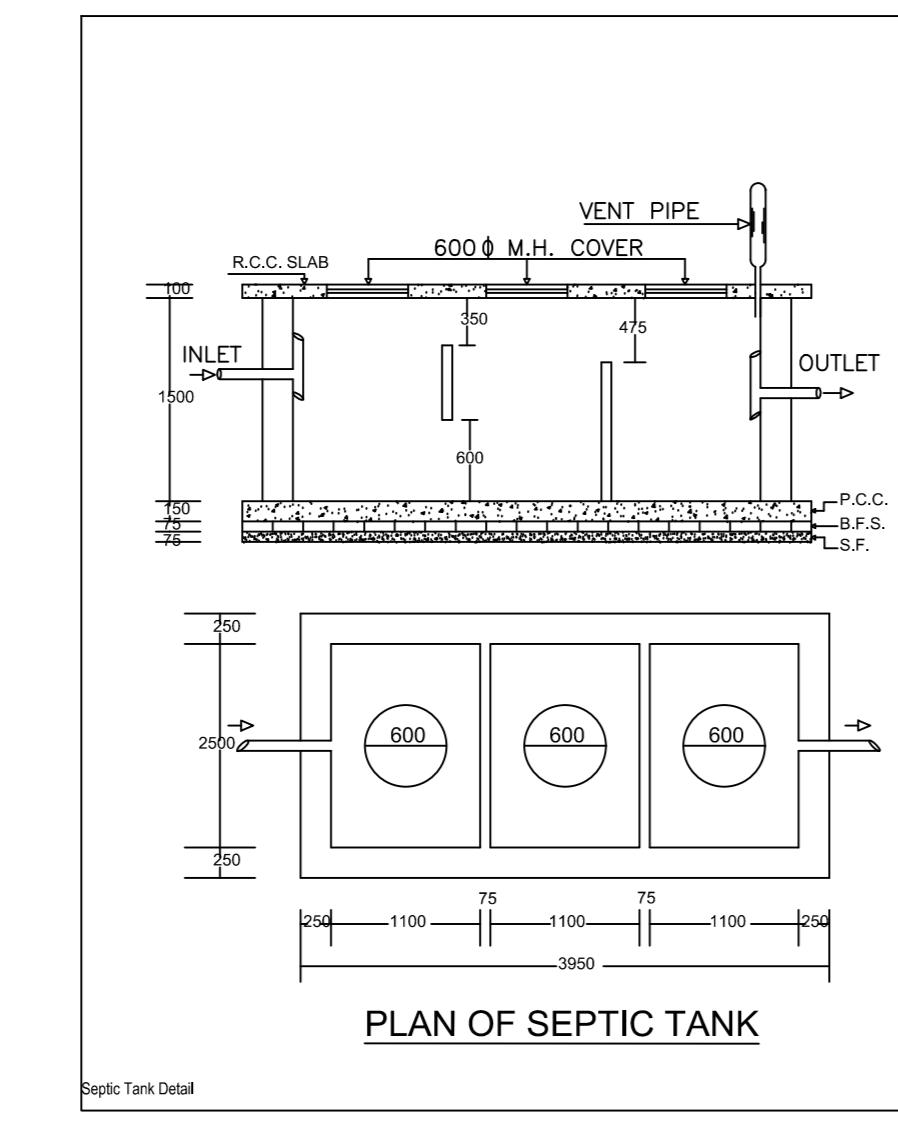
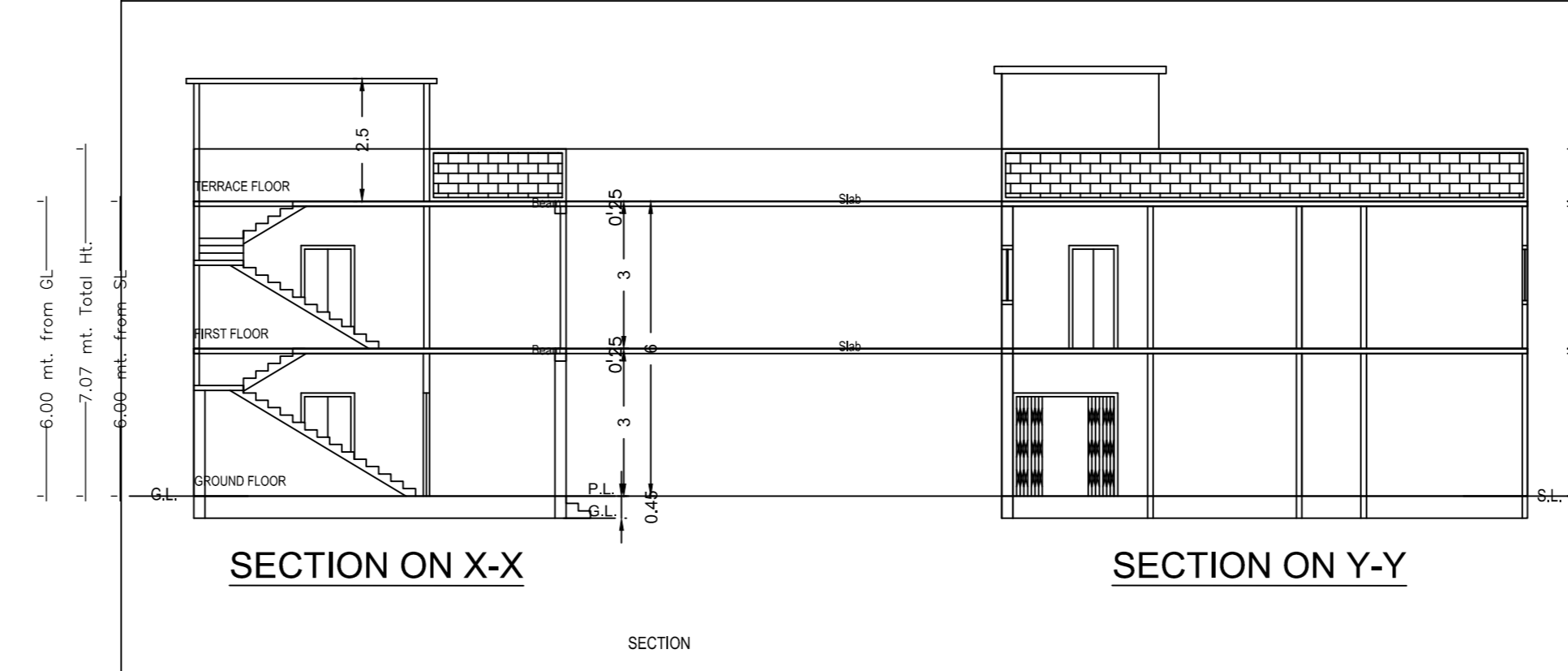
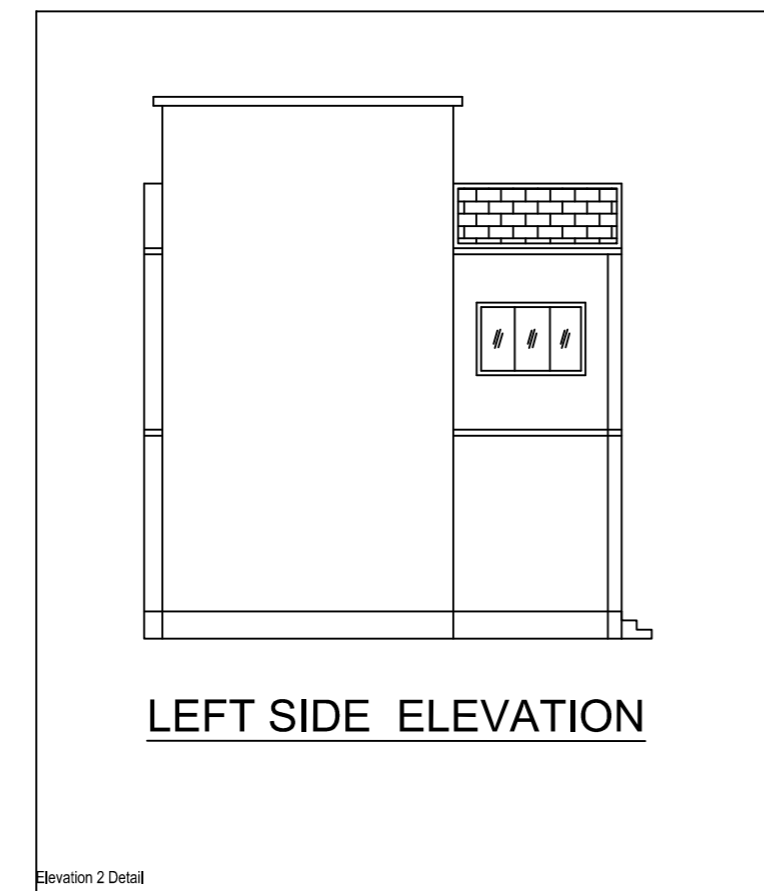
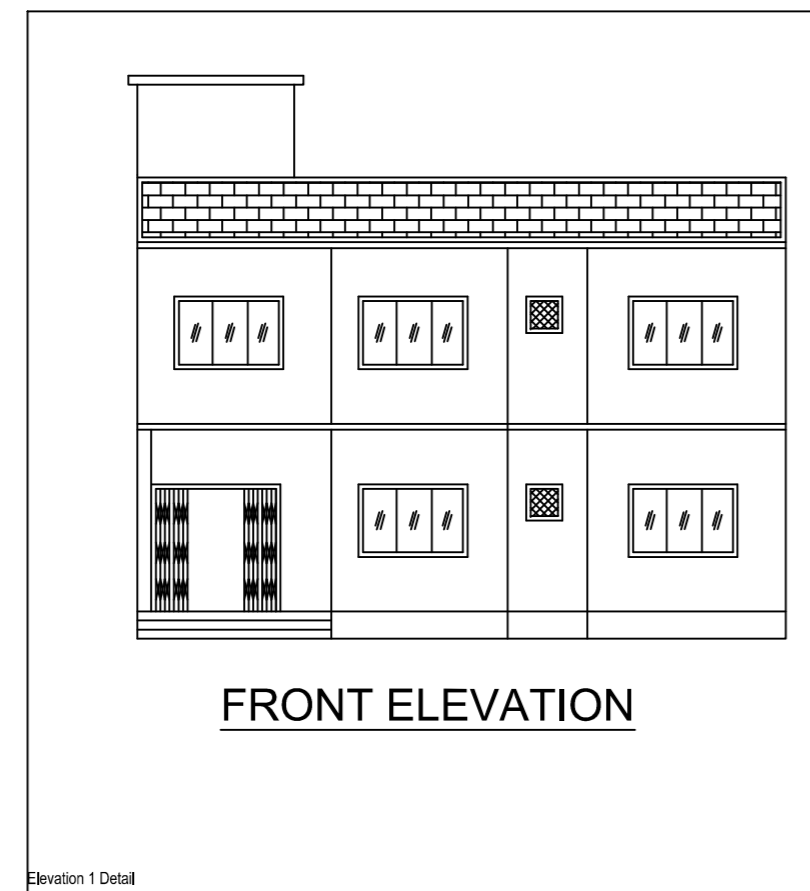
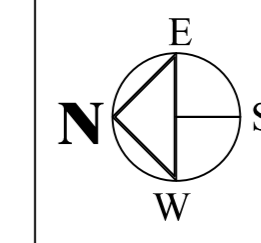

BRIEF SPECIFICATION
 FOUNDATION----- CEMENT CONCRETE (1:1.5:3)
 BRICK WORK IN FOUNDATION & SUPERSTRUCTURE
 FIRST CLASS BRICK WORK IN CEMENT MORTAR (1:6)
 D.P.C.-----25 D.P.C. IN CEMENT CONCRETE (1:2:4)
 FLOOR-----25 I.P.S. OVER 75 P.C.C.
 ROOF-----100 THK. R.C.C. ROOF (1:1.5:3)
 LINTEL-----150 THK. R.C.C. LINTEL (1:1.5:3)
 STAIRS----- RISE-- 150, TREAD-- 250

DETAILS OF AREA
 TOTAL AREA (AS PER DEED)----- 127.52 SQM.
 TOTAL AREA (AS PER SITE)----- 125.52 SQM.
 GROUND FLOOR AREA----- 78.75 SQM.
 FIRST FLOOR AREA----- 76.75 SQM.
 TOTAL COVERED AREA----- 153.50 SQM.
 % PLINTH AREA----- 61.14 %
 FAR----- 1.22

SCHEDULE
 D = 1.200X2.100 W = 1.800X1.200
 D1 = 1.050X2.100 V = 0.600X0.600
 D2 = 0.900X2.100

TITLE OF DRAWING
 PLAN OF PROPOSED RESIDENTIAL BUILDING OF SMT. INDU DEVI W/O LATE ANIL KUMAR SINGH OF M/4 POLICE KENDRA, NEAR SATLAJ BLOCK, POLICE LINE, HIRAPUR, P.S.- DHANBAD, DIST.- DHANBAD UNDER MOUZA - BHELATAND NO.- 89, KHATA NO.- 42(OLD), 89(NEW) PLOT NO.- 809, 810 (OLD), 1183 (NEW) IN THE DISTT. OF DHANBAD (JHARKHAND).

SIGNATURE OF OWNER

SIGNATURE OF ENGINEER

SCALE ALL DIMENSION ARE IN METRE

AREA STATEMENT DRAWING MUNICIPAL CORPORATION		VERSION NO. 1.0.20	
PROJECT NO.	PHI Use - Residential	VERSION DATE	10/10/2020
REPORT: RAJYASWARI URBAN LOCAL BODIES	PHI Use - Residential		
DISTRICT: DHANBAD	Local Use Zone - Residential		
Application Type: General Proposal	Planning Ward NO:-		
Project Type: Building Permission	Plot No.:-		
Nature of Development: New	Revenue Survey No/Range No.:-		
Location: 04 Area	Ward No.:-		
Sub Location: NA	Plot No.:-		
Ward/Area Name:-	North:-		
Ward No.:-	East:-		
Range/Block:-	West:-		
	Area:-		
	SO.MT.		
AREA OF PLOT (Meters)	01		125.52
Net W Area (Gross PFA Area)	(A-Occupations)		125.52
Occupation for Balance PFA Area from Gross PFA Area			
Total			125.52
Balance PFA Area Net PFA Area	(A-Occupations)		113.33
Proposed/Already exist			
PFA Area by Coverage (Net PFA Area)	(A-Occupations)		125.52
	(A-Occupations)		125.52
COVERAGE CHECK			
Proposed Coverage Area (E: 15 %)			18.83
Total Coverage Area (E: 15 %)			18.83
FAR CHECK			
Proposed Area of FAR			153.52
Total Area of FAR			153.52
FLOOR TOP AREA CHECK			
Total Proposed Floor Area			153.52
EXISTING FLOOR AREA (Proposed)			0.00
DEVELOPMENT AUTHORITY			
			LOCAL BODY

COLOR INDEX	
PLINTH BOUNDARY	—————
ADJUTING ROAD	—————
PROPOSED FLOOR COVERAGE AREA	—————
EXISTING (To be retained)	—————
EXISTING (To be demolished)	—————

COLOR INDEX	
Color from	—————
MARGIN DETAIL	—————
ROAD NAME	—————
ROAD WIDTH	—————
ROAD TYPE	—————
ROAD NO.	—————
ROAD DIST.	—————

FAR & Tenement Details (Table 40-1)					
Building	No. of Same Bldg	Total Built Up Area (Sq.Mt.)	Proposed FAR Area (Sq.Mt.)	Total FAR Area (Sq.Mt.)	Tenement (No.)
AA (AA)	1	153.50	153.50	153.50	01
Grand Total:	1	153.50	153.50	153.50	01

Building -AA (AA)				
Floor Name	Total Built Up Area (Sq.Mt.)	Proposed FAR Area (Sq.Mt.)	Total FAR Area (Sq.Mt.)	Tenement (No.)
Ground Floor	78.75	78.75	78.75	01
First Floor	76.75	76.75	76.75	01
Terrace Floor	0.00	0.00	0.00	00
Total	153.50	153.50	153.50	01
Total Number of Same Buildings	1			
Total	153.50	153.50	153.50	01

SCHEDULE OF JOINERY:				
BUILDING NAME	NAME	LENGTH	HEIGHT	NO. OF
AA(AA)	D	0.78	2.10	10
AA(AA)	D	0.99	2.10	05
AA(AA)	D	1.03	2.10	04
AA(AA)	D	1.09	2.10	02
AA(AA)	D	1.22	2.10	02
AA(AA)	D	1.14	2.10	03
AA(AA)	C.G.	2.13	2.10	01
Total				25

SCHEDULE OF JOINERY:				
BUILDING NAME	NAME	LENGTH	HEIGHT	NO. OF
AA(AA)	W	0.92	1.20	04
AA(AA)	W	0.92	1.20	02
AA(AA)	W	1.00	1.20	10
Total				16

UNBIBU Table for Building -AA (AA)						
FLOOR	Name	UNBIBU Type	UNBIBU Area	Carpet Area	No. of Rooms	No. of Tenement
GROUND FLOOR	SPLIT AA	PLAT	153.49	153.30	2	1
Total			153.49	153.30	14	1