

Proposal Basic Information

Proposal File No.	DMC/BP/0338/W22/2021
Owner Name	Rohit Kumar Choudhary and Mohit Kumar choudhary
Khata No	88(new : 1287)
Plot No	2104(new : 1937 , 1938)
Village Name	Saraidhela
Use	Residential
SubUse	Bungalow/ Dwelling / Non Apartment

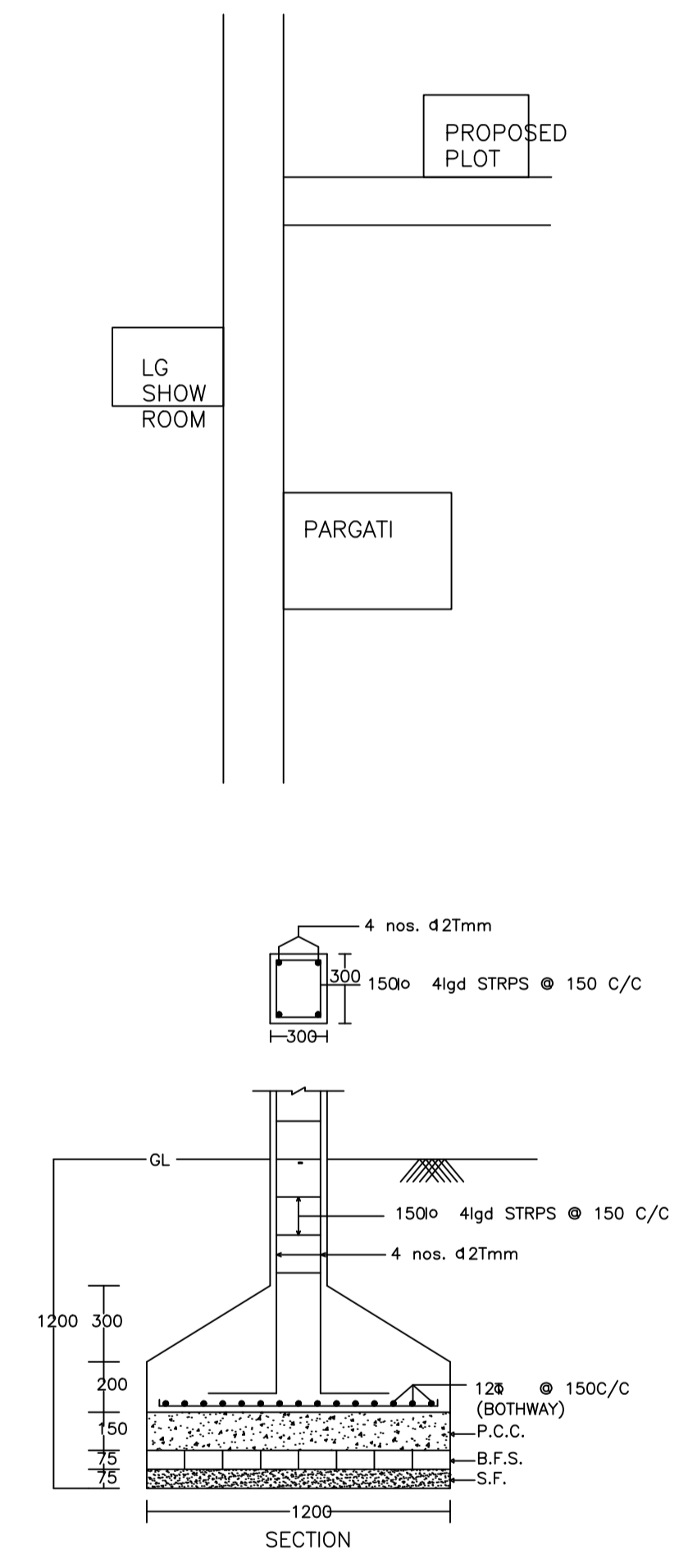
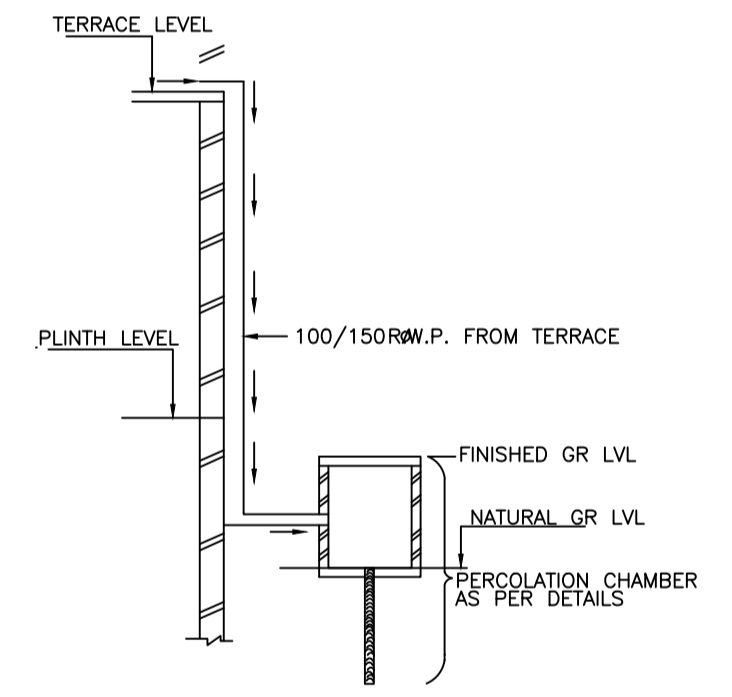
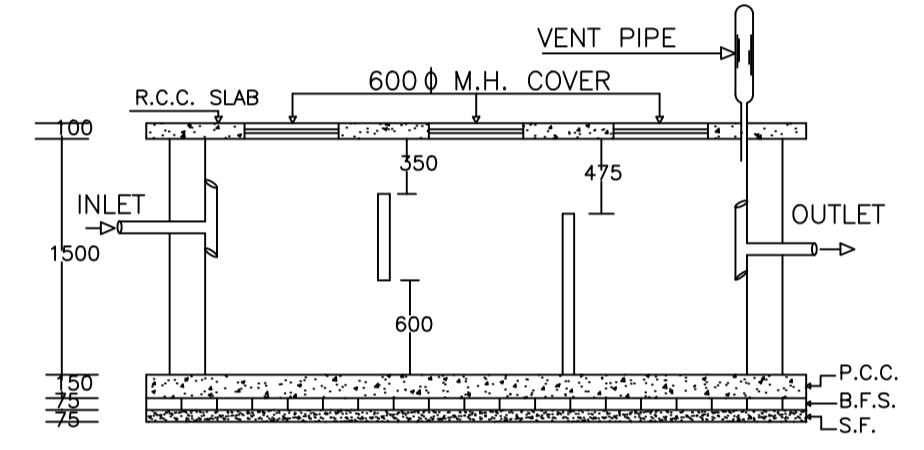
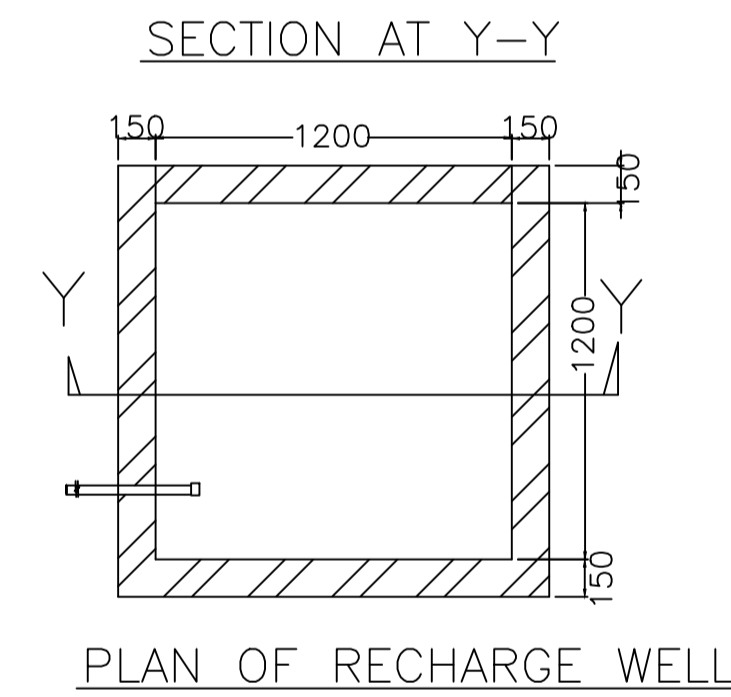
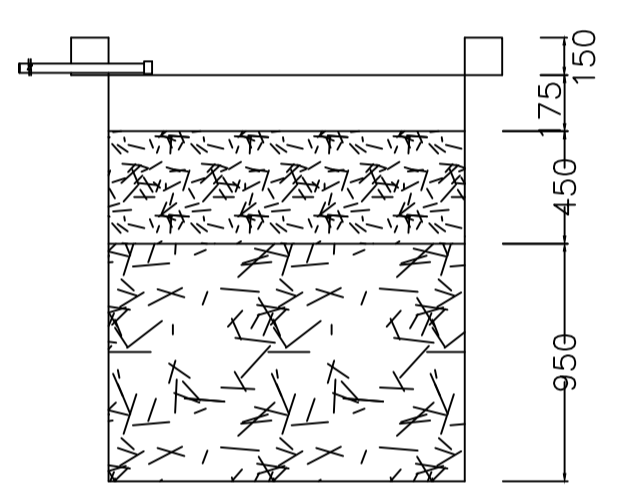
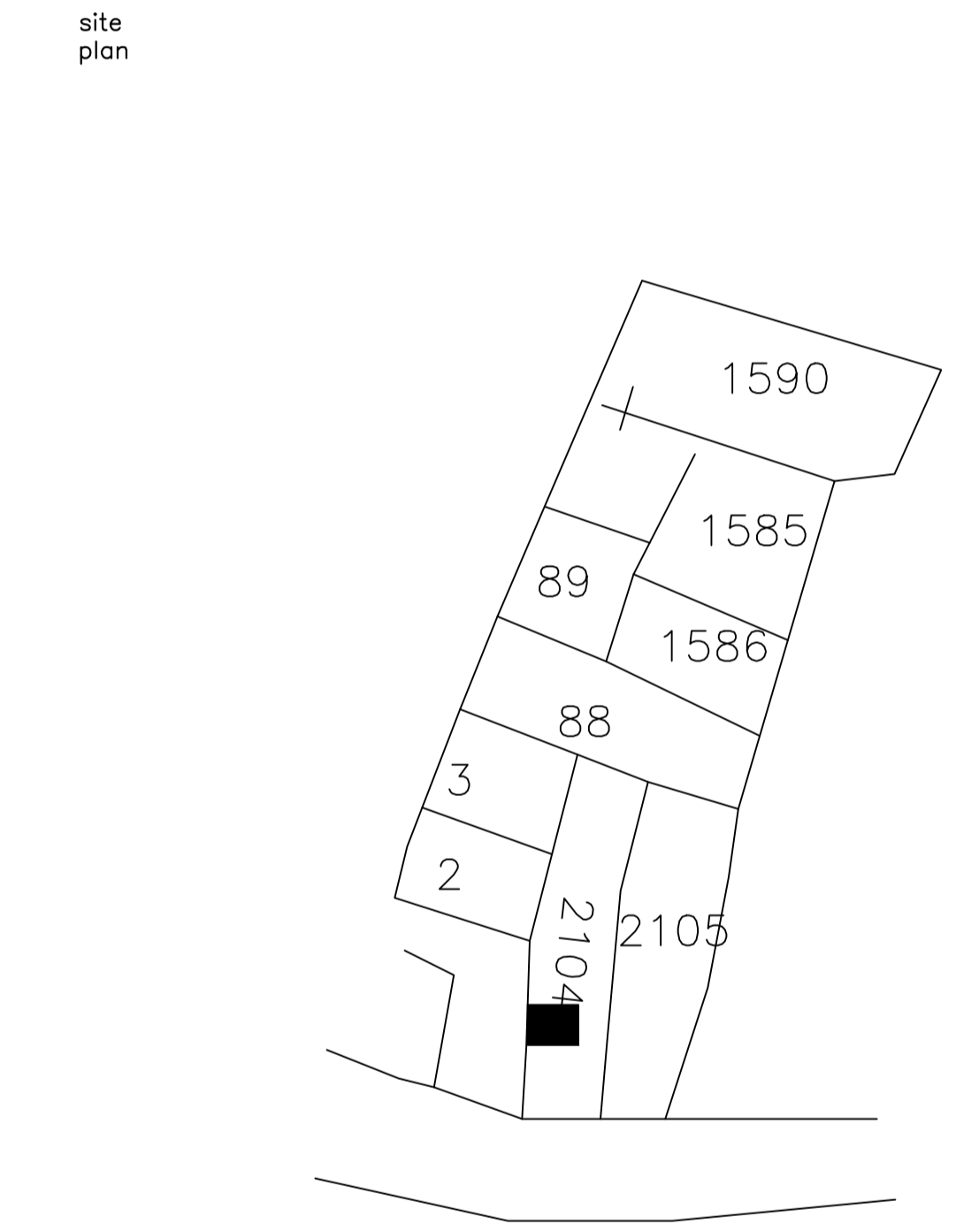
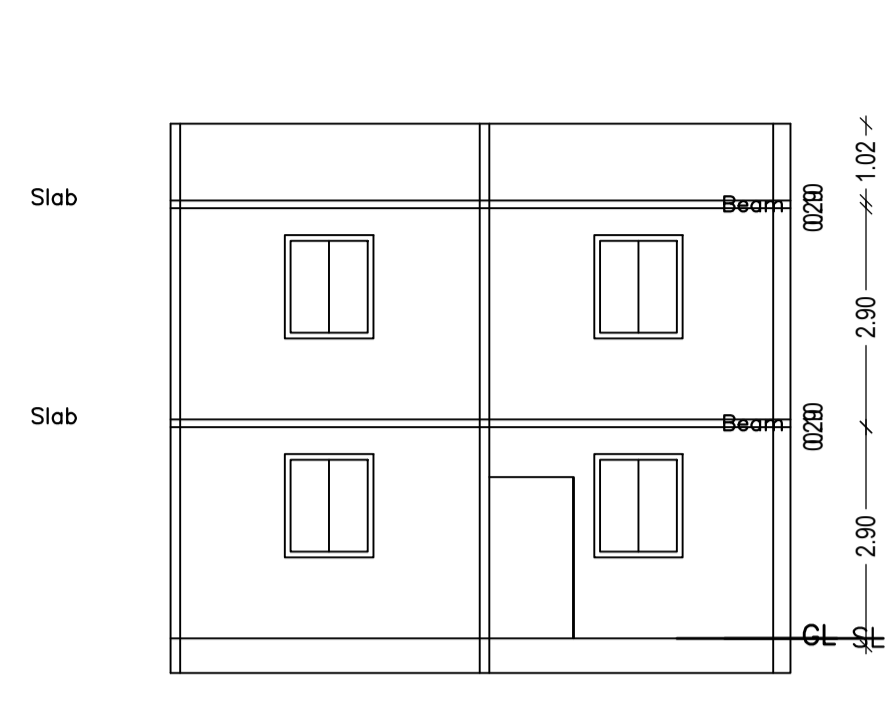
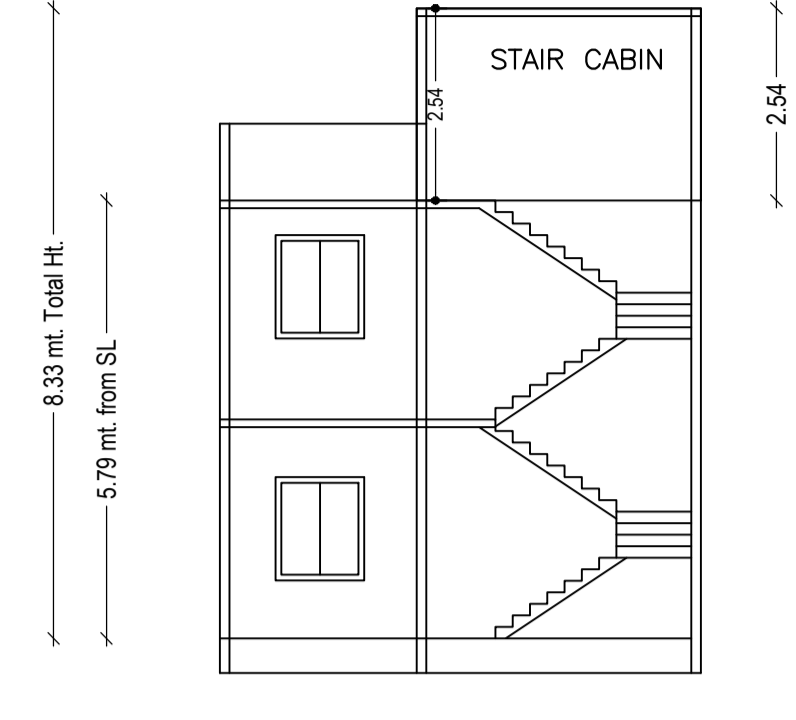
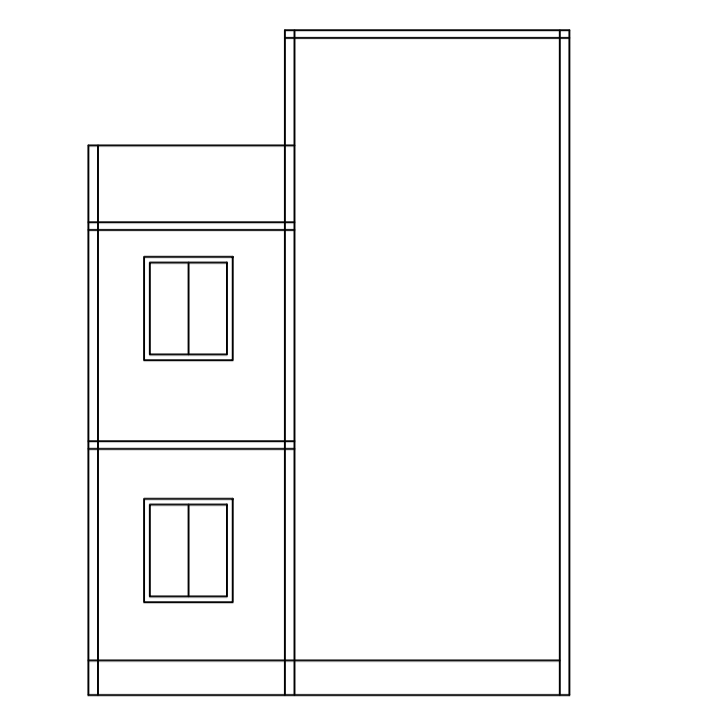
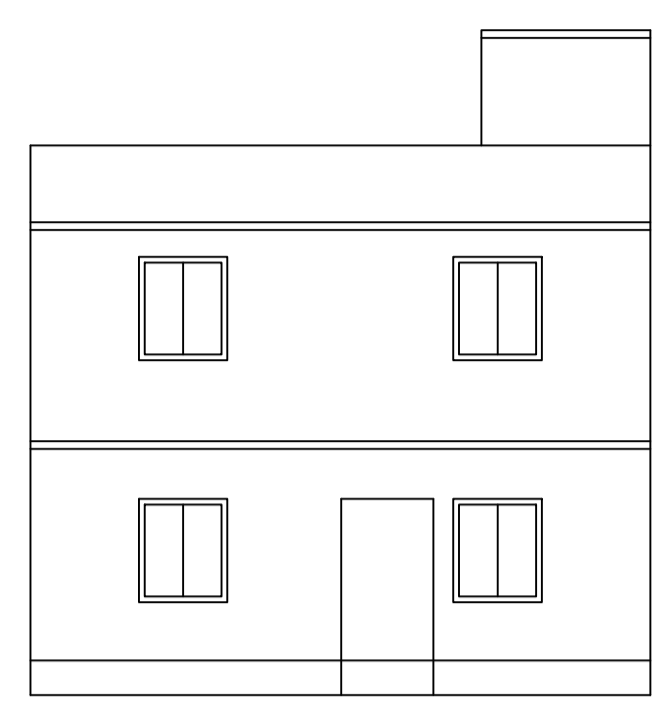
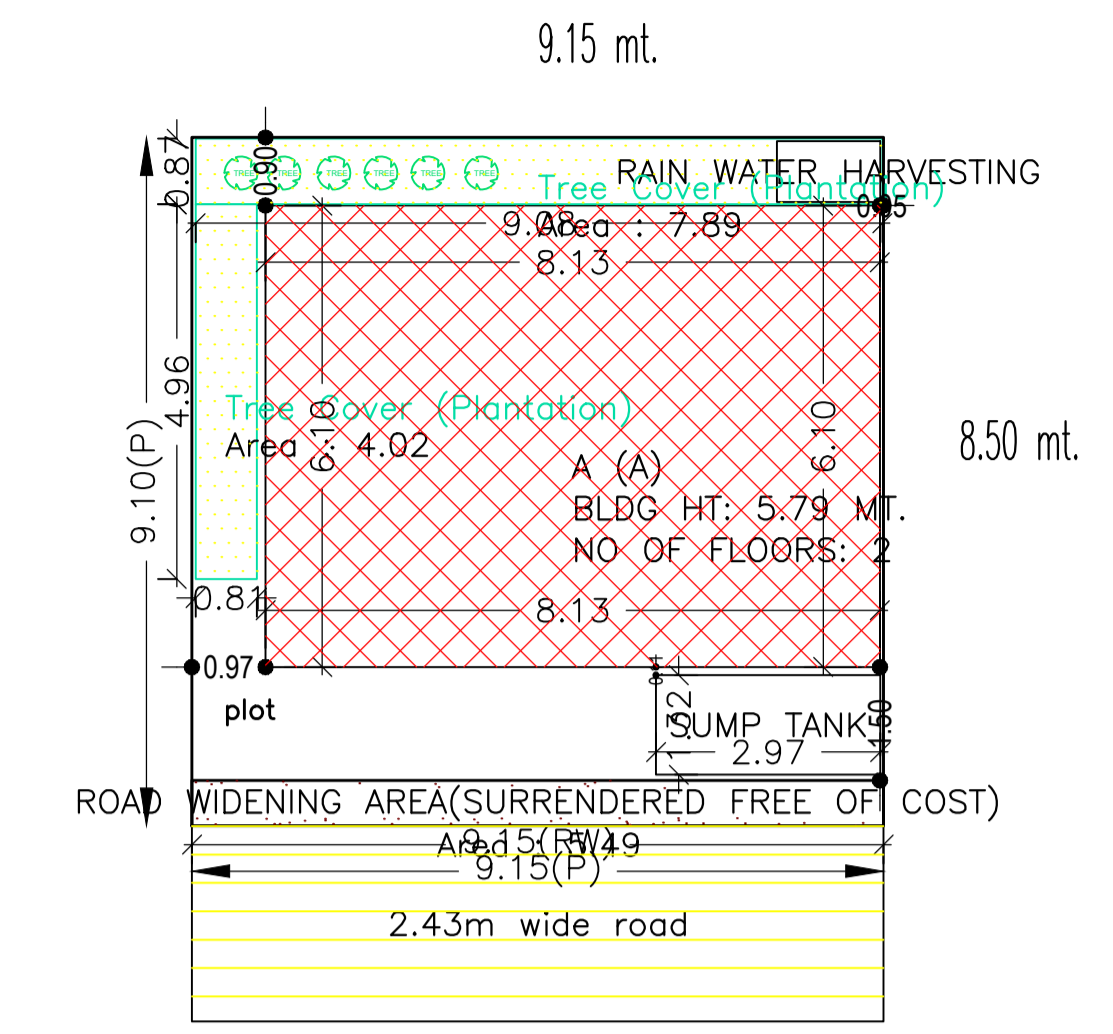

Building USE/SUBUSE Details

Building Name	Building Use	Building SubUse	Building Structure
A (A)	Residential	Residential Bldg/Apartment	Non-Highrise

SCHEDULE OF DOOR:

BUILDING NAME	NAME	LENGTH	HEIGHT	NOS
A (A)	D	0.86	2.10	02
A (A)	D	0.99	2.10	01
A (A)	D	1.07	2.10	02

SCHEDULE OF WINDOW/VENTILATION:

BUILDING NAME	NAME	LENGTH	HEIGHT	NOS
A (A)	W	0.94	1.20	02
A (A)	W	1.80	1.20	06

Building :A (A)

Floor Name	Total Built Up Area (Sq.mt.)	Proposed FAR Area (Sq.mt.) Resi.	Total FAR Area (Sq.mt.)	Total Consumed Additional FAR Area (Sq.mt.)	Tnmt (No.)
Ground Floor	49.61	49.61	49.61	49.61	01
First Floor	49.61	49.61	49.61	49.61	00
Terrace Floor	0.00	0.00	0.00	0.00	00
Total :	99.22	99.22	99.22	99.22	01
Total Number of Same Buildings	1				
Total :	99.22	99.22	99.22	99.22	01

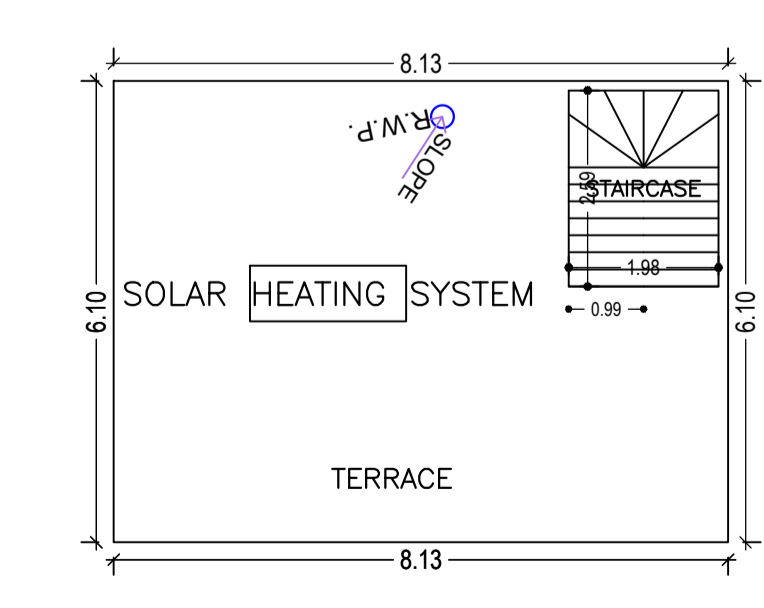
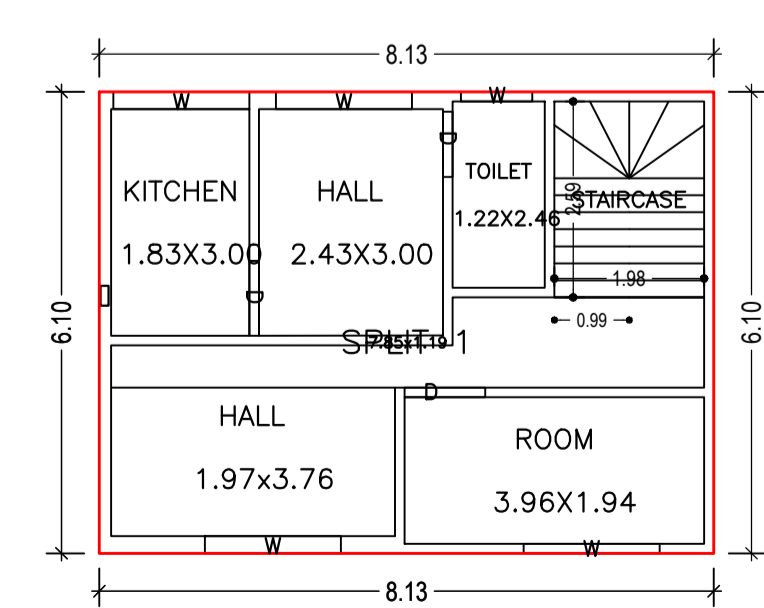
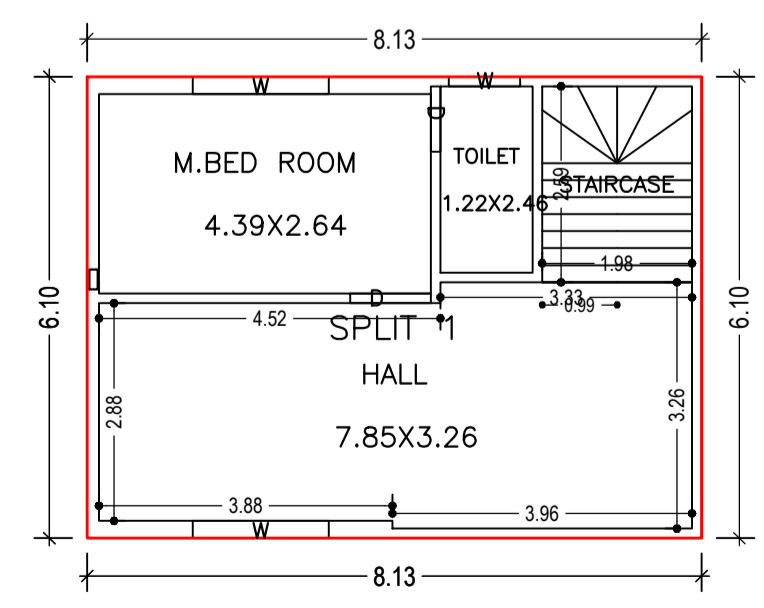

AREA STATEMENT

VERSION NO.:	1.0.61
VERSION DATE:	16/10/2020

PROJECT DETAIL:

Region: JHARKHAND URBAN LOCAL BODIES	Plot Use: Residential
District: DHANBAD CORPORATION	Plot SubUse: Bungalow/ Dwelling / Non Apartment
Authority: DHANBAD MUNICIPAL CORPORATION	PlotNearbyReligiousStructure: NA
Inward No: DMC/BP/0338/W22/2021	Plot/SubPlot No: 2104(new : 1937 , 1938)
Application Type: General Proposal	North: Road Width - mathura prasad
Project Type: Building Permission	South: Plot No - rekha kumar
Nature of Development: New	East: Road Width - 3.66
Location of Development Area: Old Area	West: Plot No. - open land

AREA DETAILS:

AREA OF PLOT (Minimum)	(A)	SQ.MT.	83.30
Deduction for NetPlot Area			
Surrender Free of Cost			5.49
Total			5.49
NET AREA OF PLOT (Gross Plot Area - Deduction from Gross Plot area)	(A-Deductions)		77.81
Deduction for Balance Plot Area (from Gross Plot Area)			
Surrender Free of Cost			5.49
Common Plot			11.91
Total			17.40
BALANCE AREA OF PLOT (Net Plot Area - Recreational/Amenity space)	(A-Deductions)		65.90
PLOT AREA FOR COVERAGE (Net Plot Area)	(A-Deductions)		77.81
Plot Area for FAR (Net Plot Area + Road Widening Area)	(A-Deductions)		83.30

COVERAGE CHECK

Permissible Coverage area (70.00 %)		54.47
Proposed Coverage Area (63.76 %)		49.61
Total Prop. Coverage Area (63.76 %)		49.61
Balance coverage area (6.25 %)		4.86

FAR CHECK

Perm. FAR Area (1.20)		99.96
Total Perm. FAR area		99.96
Residential FAR		99.22
Proposed FAR Area		99.22
Total Proposed FAR Area		99.22
Consumed FAR (Factor)		1.19
Balance FAR Area		0.74

BUILT UP AREA CHECK

Total Proposed BuiltUp Area		99.22
-----------------------------	--	-------

ARCHITECT (Regd): ABHISHEK KUMAR
ENGINEER (Regd):
SUPERVISOR (Regd):
OWNER (Regd): Rohit Kumar Choudhary and Mohit Kumar choudhary

DEVELOPMENT AUTHORITY: LOCAL BODY

COLOR INDEX

PLOT BOUNDARY	Black
ABUTTING ROAD	Red
PROPOSED CONSTRUCTION	Green
COMMON PLOT	Yellow
ROAD WIDENING AREA	Blue
EXISTING (To be retained)	Orange
EXISTING (To be demolished)	Grey

Buildingwise Floor FAR Details

Floor Name	Building Name		Total	
	Proposed Built Up Area (Sq.mt.)	Proposed FAR Area (Sq.mt.)	Total Proposed Built Up Area (Sq.mt.)	Total FAR Area (Sq.mt.)
Ground Floor	49.61	49.61	49.61	49.61
First Floor	49.61	49.61	49.61	49.61
Terrace Floor	0.00	0.00	0.00	0.00
Total :	99.22	99.22	99.22	99.22

FAR & Tenement Details (Table 4c-1)

Building	No. of Same Bldg	Total Built Up Area (Sq.mt.)	Proposed FAR Area (Sq.mt.) Resi.	Total FAR Area (Sq.mt.)	Total Consumed Additional FAR Area (Sq.mt.)	Tnmt (No.)
A (A)	1	99.22	99.22	99.22	99.22	01
Grand Total :	1	99.22	99.22	99.22	99.22	01

UnitBUA Table for Building :A (A)

FLOOR	Name	UnitBUA Type	UnitBUA Area	Carpet Area	No. of Rooms	No. of Tenement
GROUND FLOOR	SPLIT 1	FLAT	99.22	99.16	3	1
FIRST FLOOR	SPLIT 1	FLAT	0.00	0.00	5	0
PLAN						
Total:			99.22	99.16	8	1

LTP NAME AND SIGNATURE	STRUCTURAL ENG'S NAME AND SIGNATURE	BUILDER NAME AND SIGNATURE	DIGITAL SIGNATURE
ABHISHEK KUMAR DMC/DFTMN/0013/2020			