

Proposal Basic Information	
Proposal File No.	DMC/BP/0143/W23/2021
Owner Name	Vishwajeet Kumar
Khata No	01 (New 625)
Plot No	274,275(New 686,689)
Village Name	Kolakusma
Use	Residential
SubUse	Bungalow/ Dwelling / Non Apartment

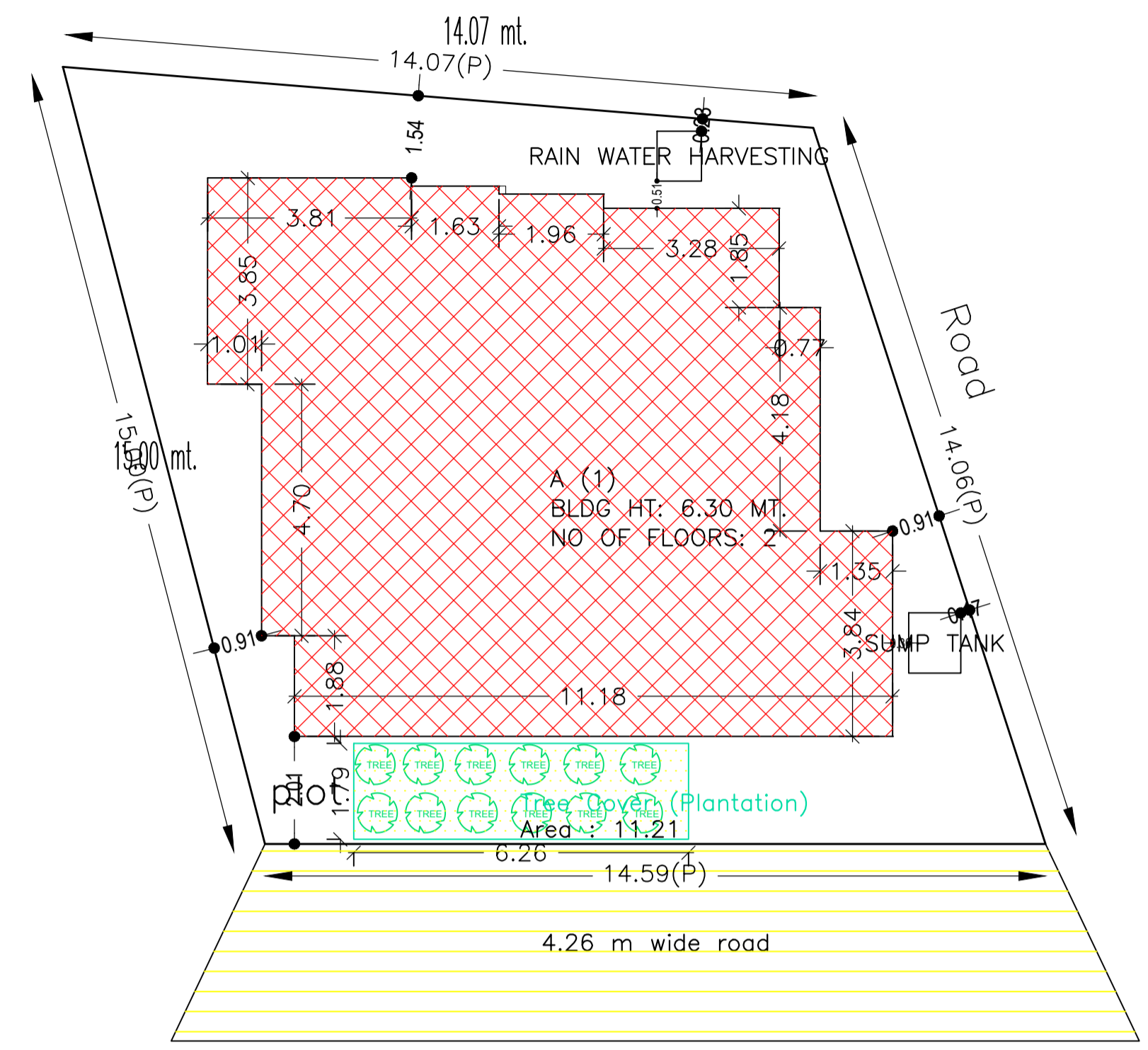

site plan

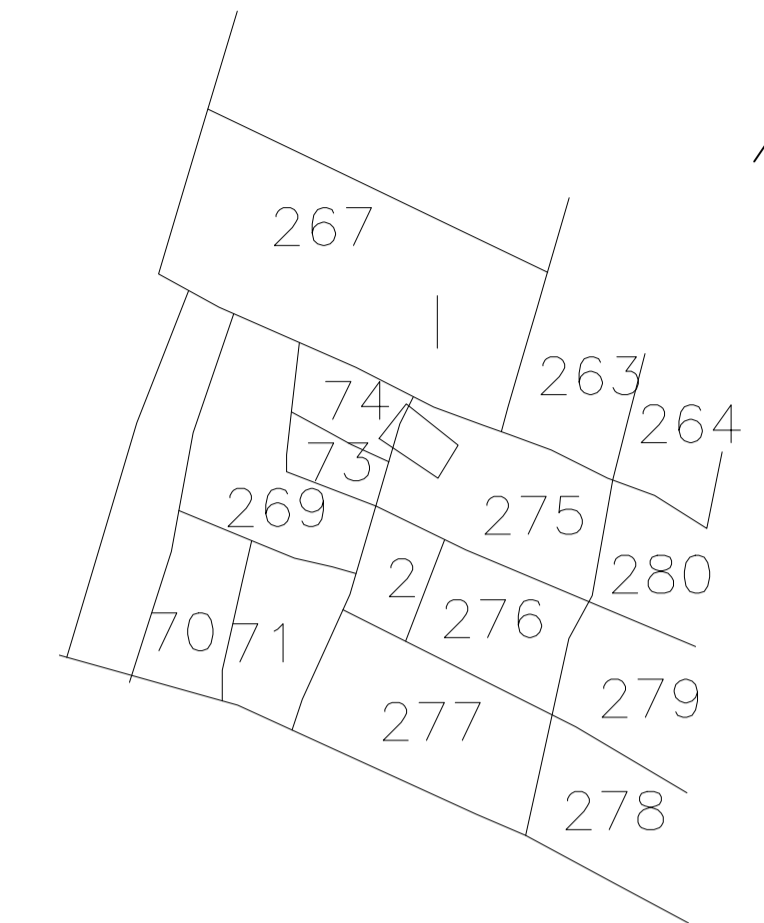
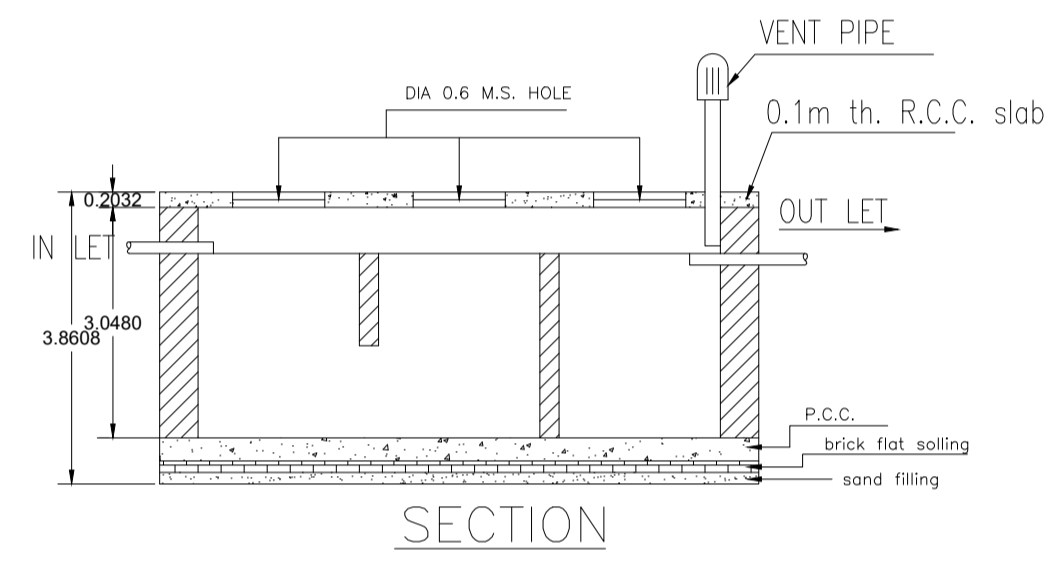
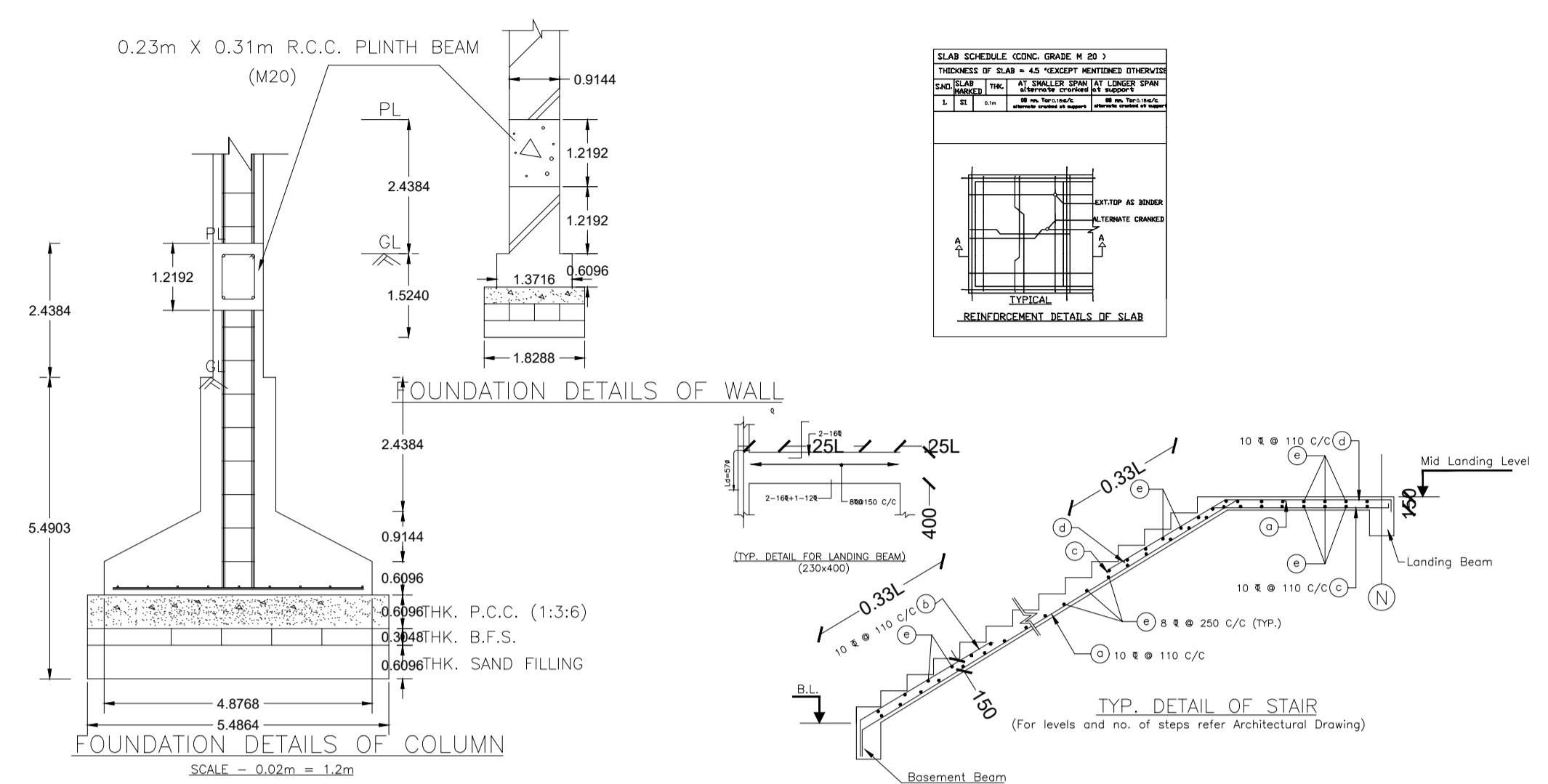
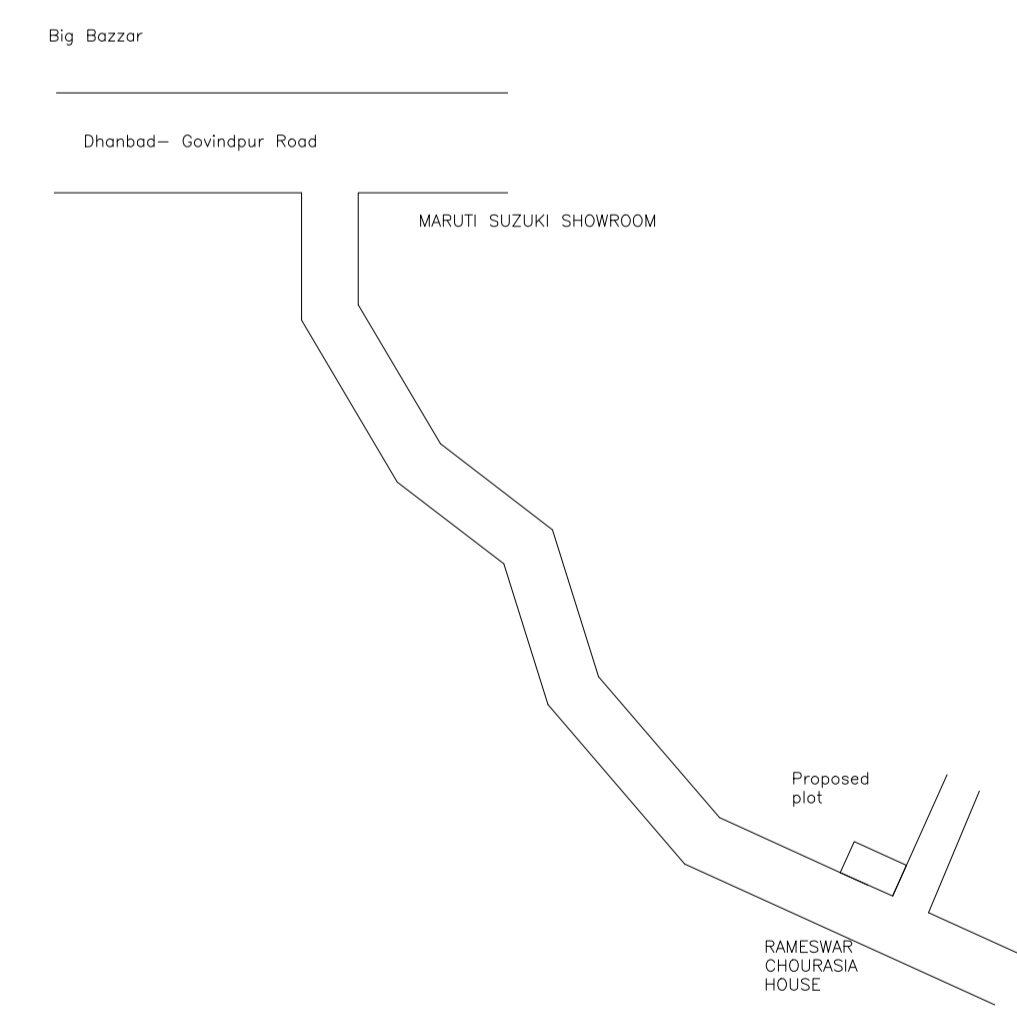

DETAILS OF SEPTIC TANK

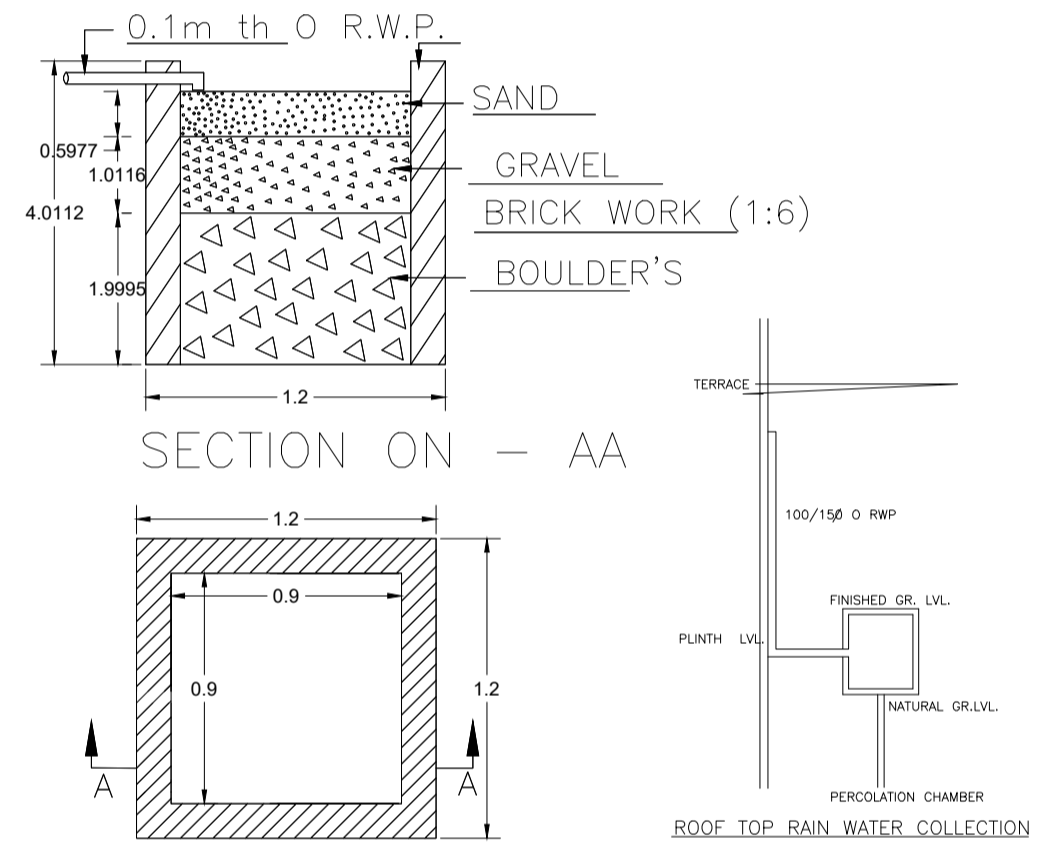
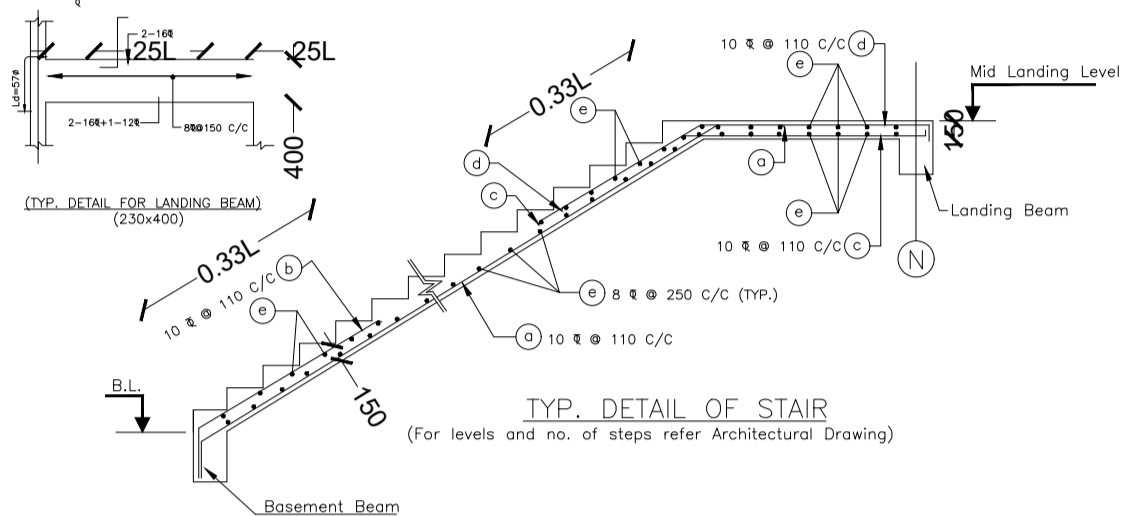

DETAIL'S OF WATER HARVESTING

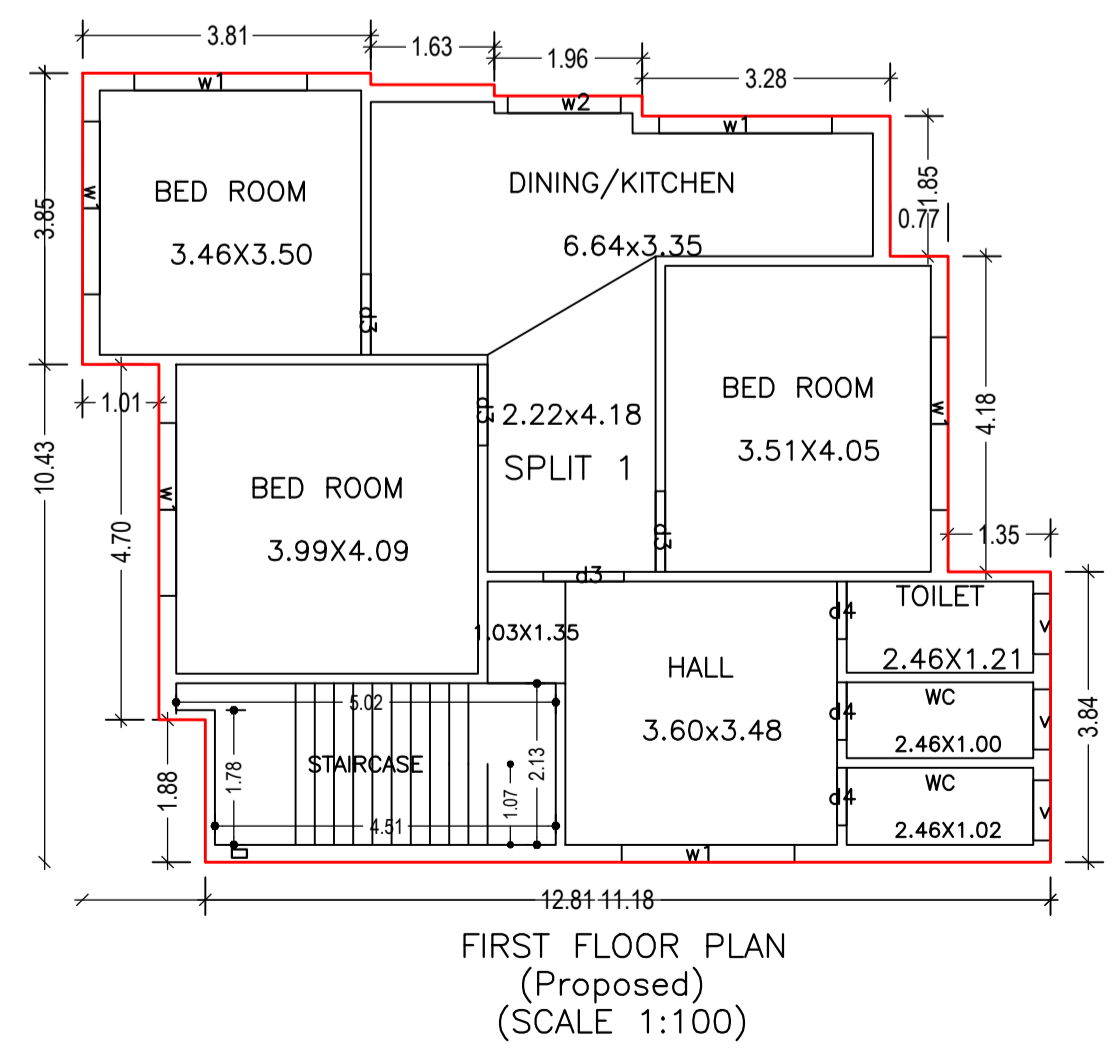
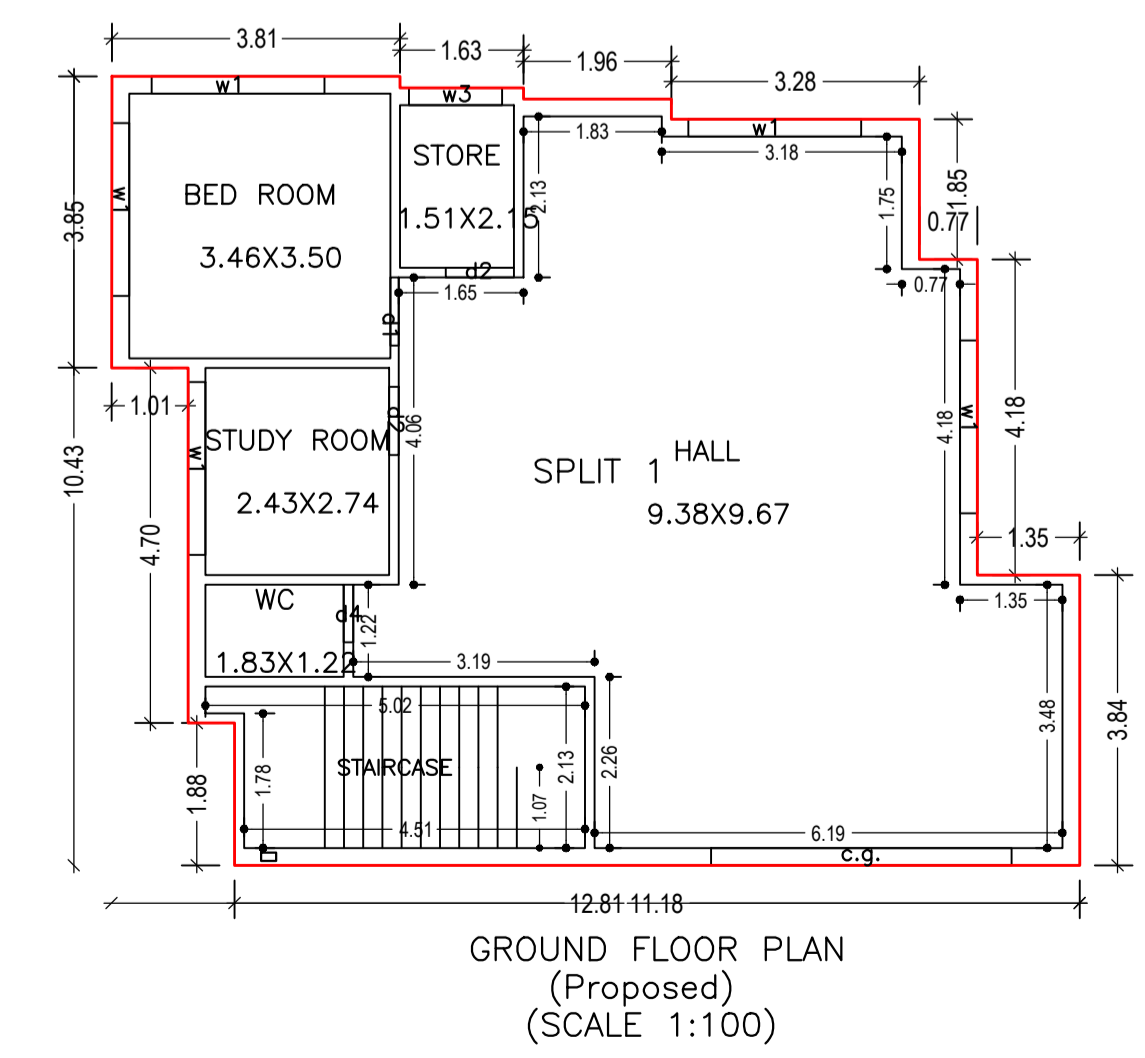
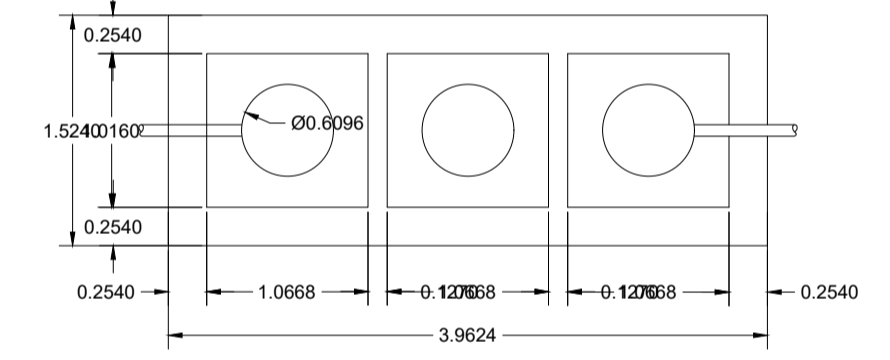

Building :A (1)

Floor Name	Total Built Up Area (Sq.mt.)	Proposed FAR Area (Sq.mt.) Resi.	Total FAR Area (Sq.mt.)	Total Consumed Additional FAR Area (Sq.mt.)	Trmt (No.)
Ground Floor	112.29	112.29	112.29	112.29	01
First Floor	112.29	112.29	112.29	112.29	00
Terrace Floor	0.00	0.00	0.00	0.00	00
Total :	224.58	224.58	224.58	224.58	01
Total Number of Same Buildings :	1				
Total :	224.58	224.58	224.58	224.58	01

SCHEDULE OF DOOR:

BUILDING NAME	NAME	LENGTH	HEIGHT	NOS
A (1)	d4	0.76	2.10	04
A (1)	d1	0.90	2.10	01
A (1)	d2	0.90	2.10	02
A (1)	d3	1.07	2.10	04
A (1)	c.g.	3.97	2.10	01

SCHEDULE OF WINDOW/VENTILATION:

BUILDING NAME	NAME	LENGTH	HEIGHT	NOS
A (1)	v	0.80	0.80	03
A (1)	w3	1.23	1.20	01
A (1)	w2	1.50	1.20	01
A (1)	w1	2.29	1.20	11

AREA STATEMENT		VERSION NO. : 1.0.57
DHANBAD MUNICIPAL CORPORATION		VERSION DATE: 16/10/2020
PROJECT DETAIL:		
Region : JHARKHAND URBAN LOCAL BODIES	Plot Use: Residential	
District: DHANBAD	Plot SubUse: Bungalow/ Dwelling / Non Apartment	
Authority: DHANBAD MUNICIPAL CORPORATION	PlotNearbyReligiousStructure: NA	
Inward No: DMC/BP/0143/W23/2021	Plot/SubPlot No: 274,275(New 686,689)	
Application Type: General Proposal	North: Plot No. - 275	
Project Type: Building Permission	South: Road Width - 3.8	
Nature of Development: New	East: Plot No. - 275	
Location of Development Area: Old Area	West: Road Width - 4.57	
AREA DETAILS:		
AREA OF PLOT (Minimum)	(A)	SQ.MT. 197.18
NET AREA OF PLOT(Gross Plot Area - Deduction from Gross Plot area)	(A-Deductions)	197.18
Deduction for Balance Plot Area(from Gross Plot Area)		
Common Plot		11.21
Total		11.21
BALANCE AREA OF PLOT(Net Plot Area - Recreational/Amenity space)	(A-Deductions)	185.97
PLOT AREA FOR COVERAGE(Net Plot Area)	(A-Deductions)	197.18
Plot Area for FAR (Net Plot Area + Road Widening Area)	(A-Deductions)	197.18
COVERAGE CHECK		
Permissible Coverage area (70.00 %)		138.03
Proposed Coverage Area (56.95 %)		112.29
Total Prop. Coverage Area (56.95 %)		112.29
Balance coverage area (13.05 %)		25.74
FAR CHECK		
Perm. FAR Area (1.50)		295.77
Total Perm. FAR area		295.77
Residential FAR		224.59
Proposed FAR Area		224.59
Total Proposed FAR Area		224.59
Consumed FAR (Factor)		1.14
Balance FAR Area		71.18
BUILT UP AREA CHECK		
Total Proposed BuiltUp Area		224.58
ARCHITECT (Regd)	SUSHIL KUMAR	
ENGINEER (Regd)		
SUPERVISOR (Regd)		
OWNER (Regd)	Vishwajeet Kumar	
DEVELOPMENT AUTHORITY		LOCAL BODY

COLOR INDEX

PLOT BOUNDARY	Black
ABUTTING ROAD	Green
PROPOSED CONSTRUCTION	Red
COMMON PLOT	Yellow
ROAD WIDENING AREA	Orange
EXISTING (To be retained)	Blue
EXISTING (To be demolished)	Light Blue

Buildingwise Floor FAR Details

Floor Name	Building Name A (1)		Total	
	Proposed Built Up Area (Sq.mt.)	Proposed FAR Area (Sq.mt.)	Total Proposed Built Up Area (Sq.mt.)	Total FAR Area (Sq.mt.)
Ground Floor	112.29	112.29	112.29	112.29
First Floor	112.29	112.29	112.29	112.29
Terrace Floor	0.00	0.00	0.00	0.00
Total :	224.58	224.58	224.58	224.58

Building USE/SUBUSE Details

Building Name	Building Use	Building SubUse	Building Structure
A (1)	Residential	Residential Bldg/Apartment	Non-Highrise

FAR & Tenement Details (Table 4c-1)

Building	No. of Same Bldg	Total Built Up Area (Sq.mt.)	Proposed FAR Area (Sq.mt.) Resi.	Total FAR Area (Sq.mt.)	Total Consumed Additional FAR Area (Sq.mt.)	Trmt (No.)
A (1)	1	224.58	224.58	224.58	224.58	01
Grand Total :	1	224.58	224.58	224.58	224.58	01

UnitBUA Table for Building :A (1)

FLOOR	Name	UnitBUA Type	UnitBUA Area	Carpet Area	No. of Rooms	No. of Tenement
GROUND FLOOR PLAN	SPLIT 1	FLAT	224.59	224.54	5	1
FIRST FLOOR PLAN	SPLIT 1	FLAT	0.00	0.00	8	0
Total:	-	-	224.59	224.54	13	1

LTP NAME AND SIGNATURE	STRUCTURAL ENG'S NAME AND SIGNATURE	BUILDER NAME AND SIGNATURE	DIGITAL SIGNATURE
SUSHIL KUMAR DMC/ENG/0005/2016			

Proposal Basic Information	
Proposal File No.	DMC/BP/0143/W23/2021
Owner Name	Vishwajeet Kumar
Khata No	01 (New 625)
Plot No	274.275(New 686.689)
Village Name	Kolakusma
Use	Residential
SubUse	Bungalow/ Dwelling / Non Apartment

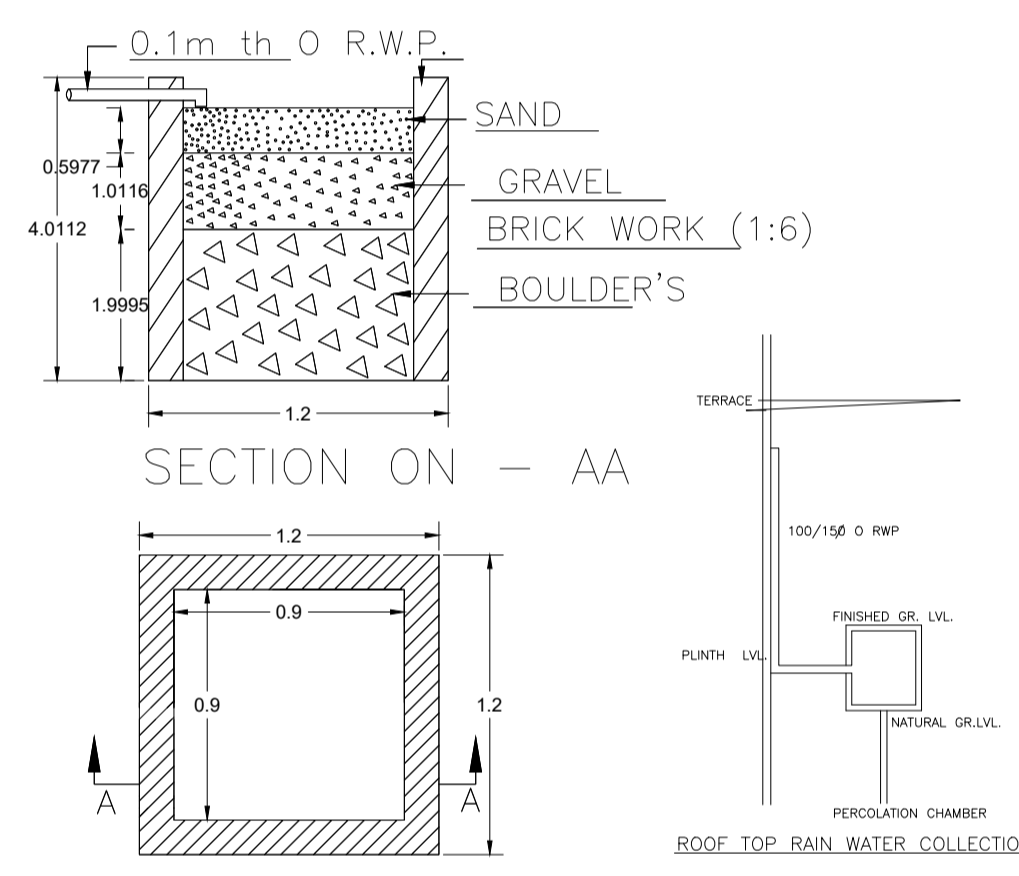
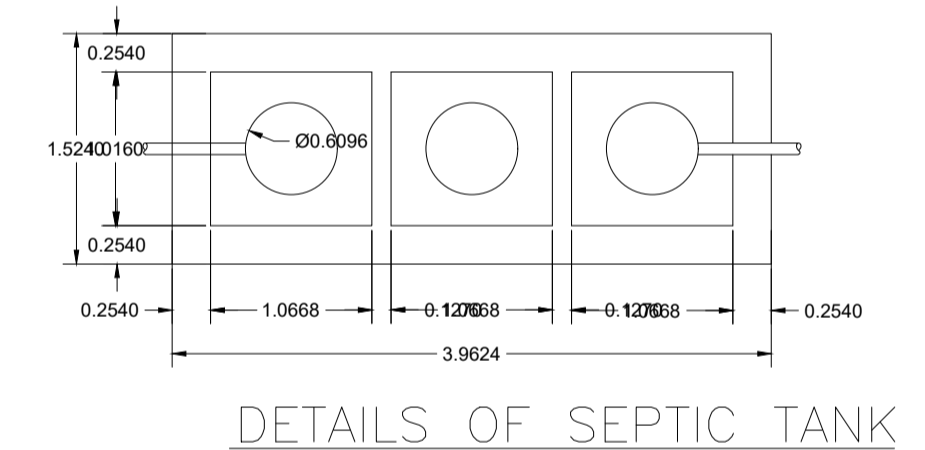
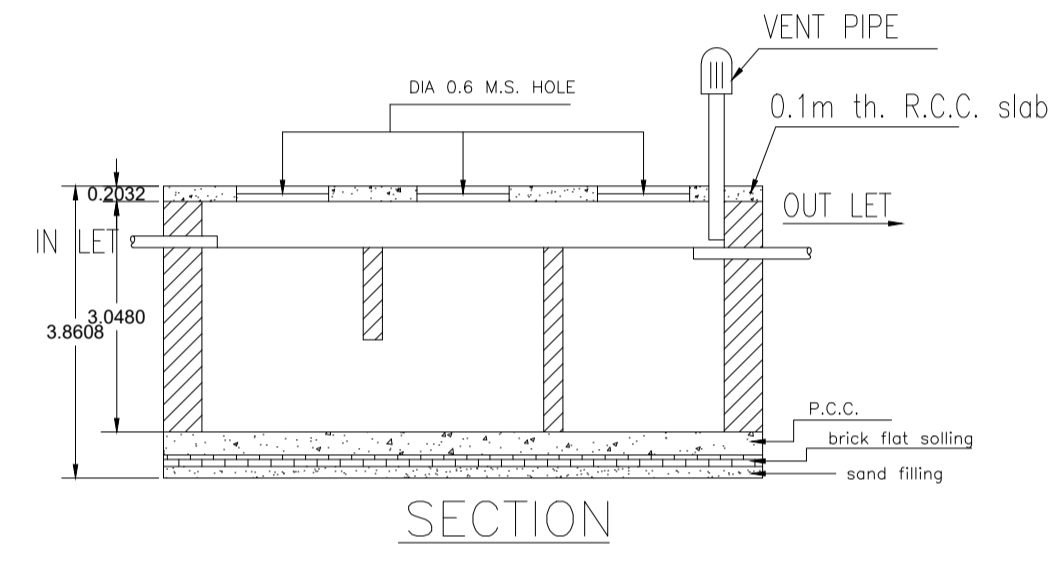
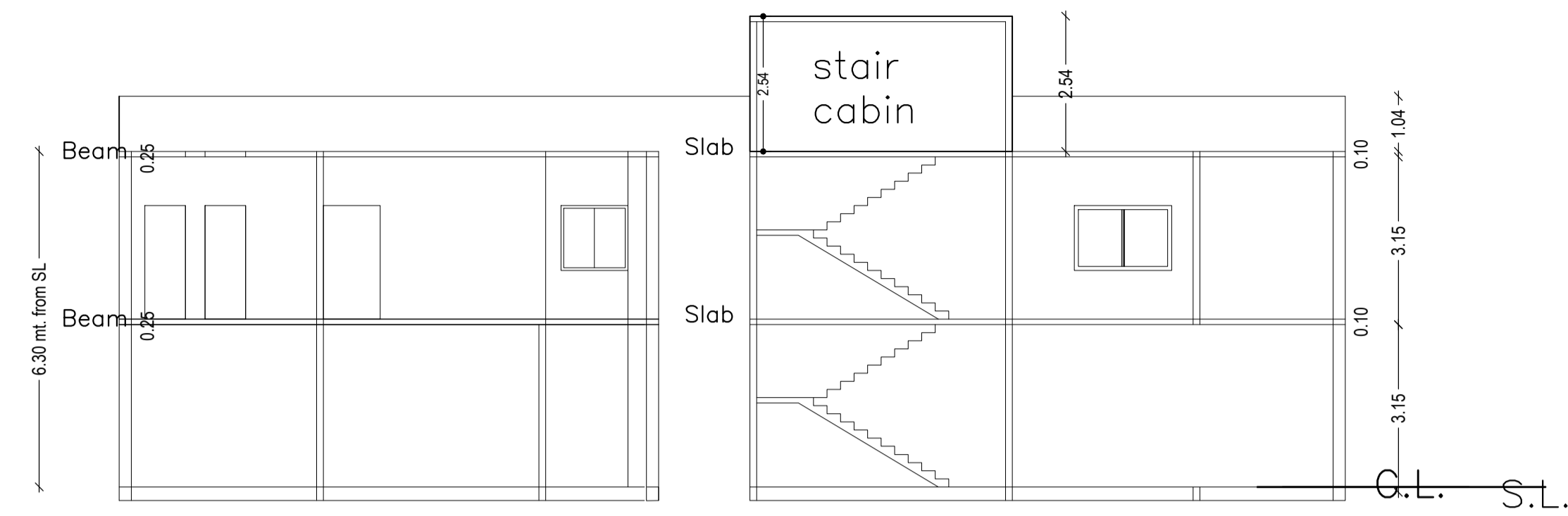
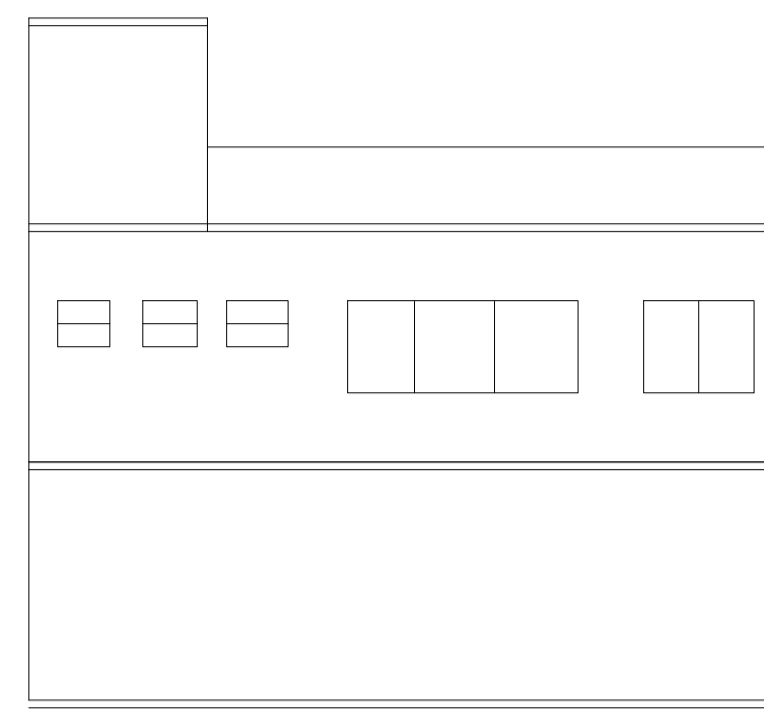
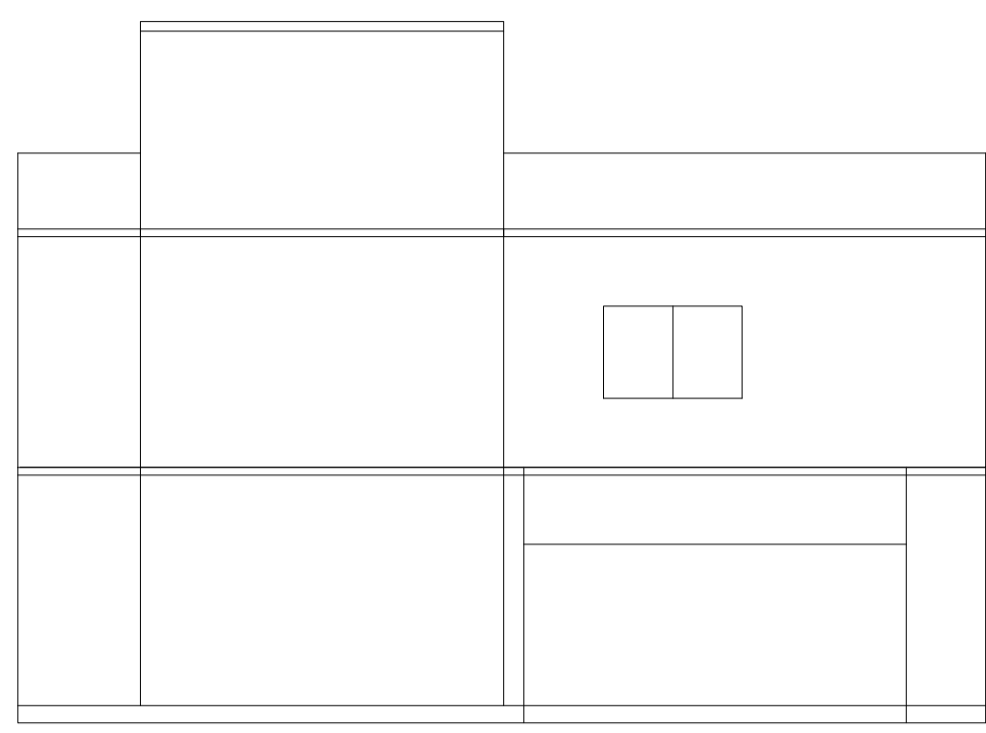

DETAIL'S OF WATER HARVESTING

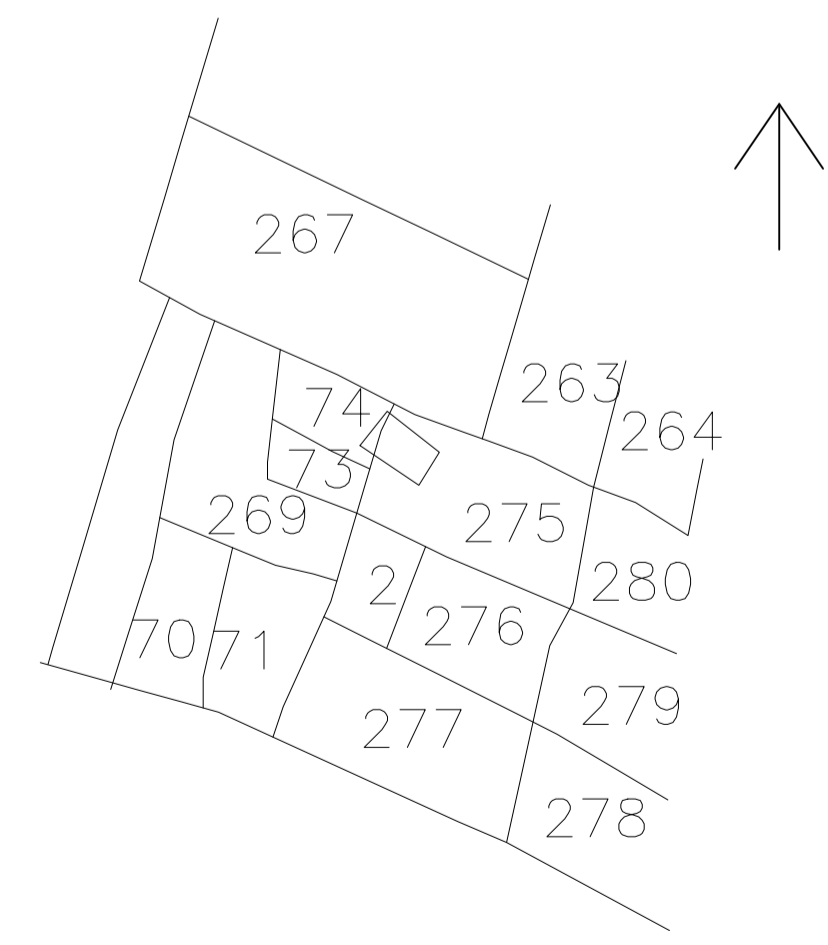
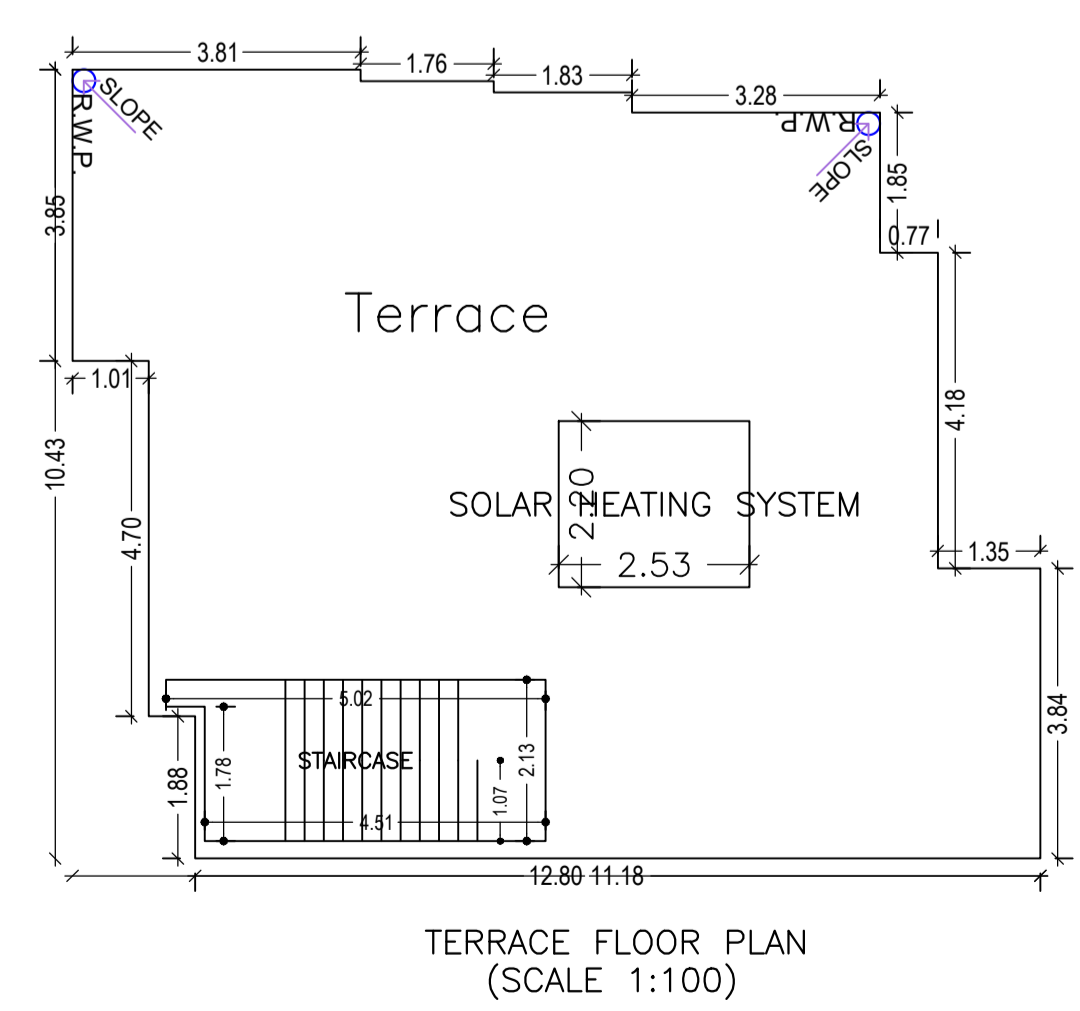
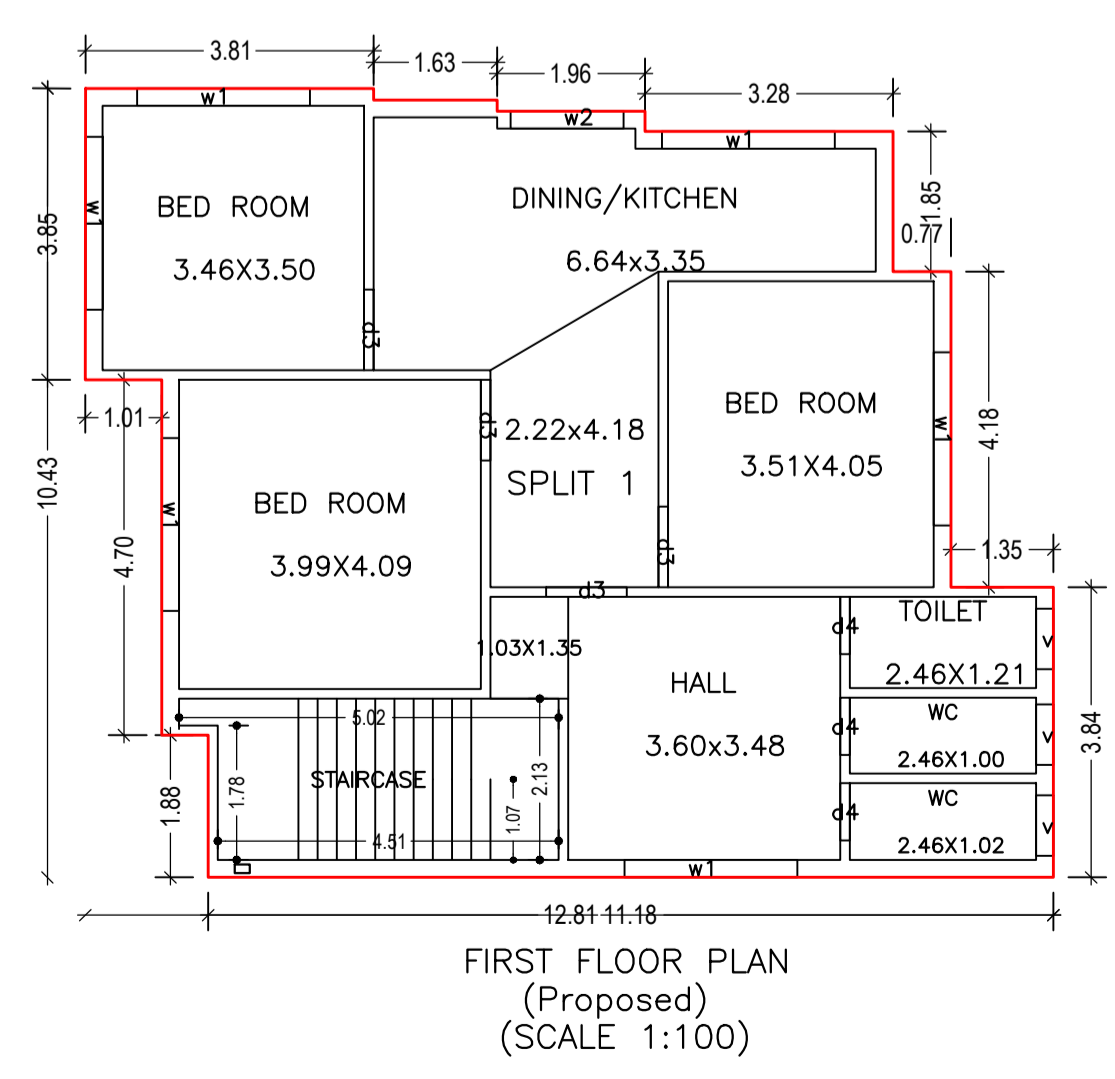
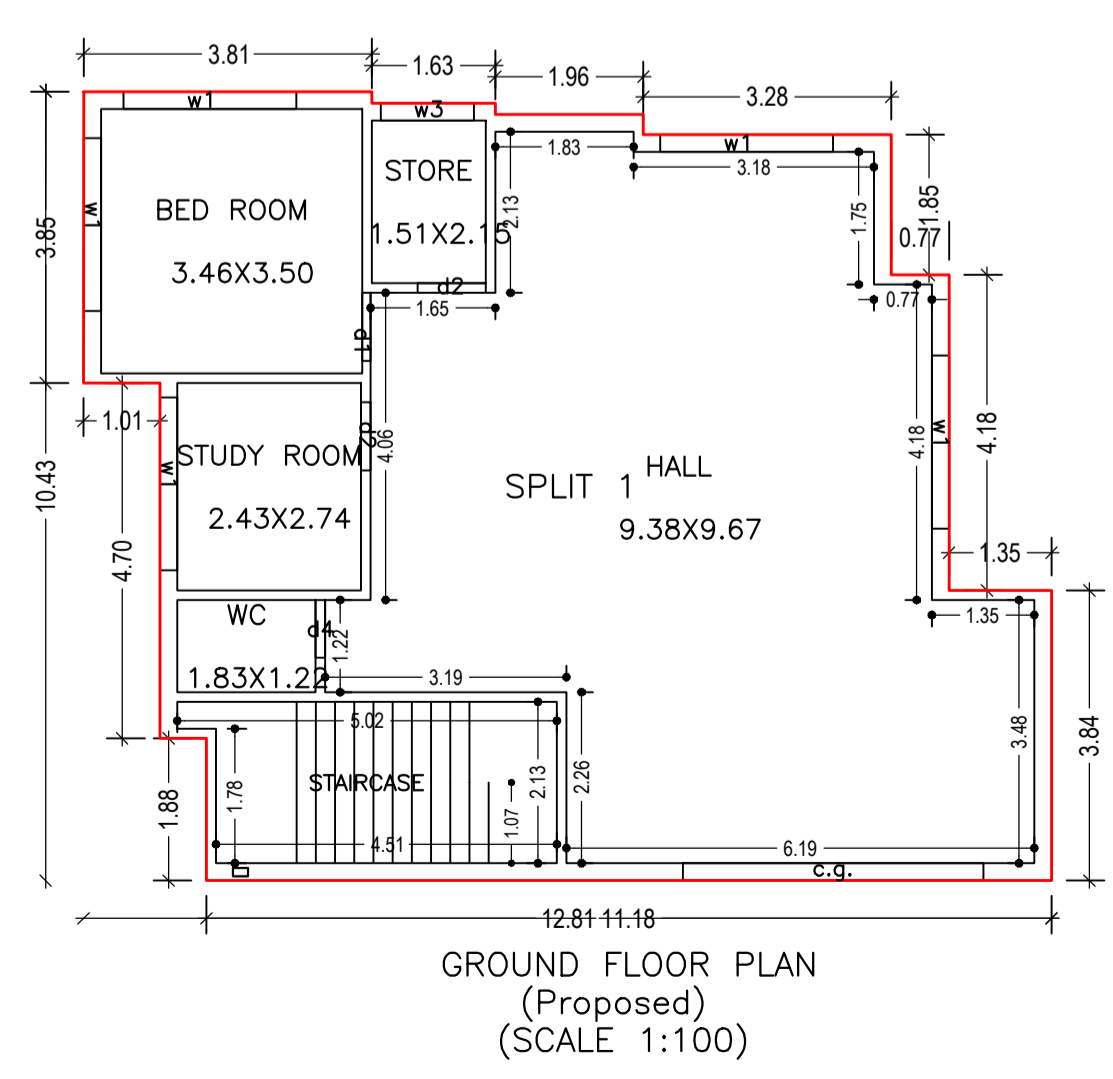
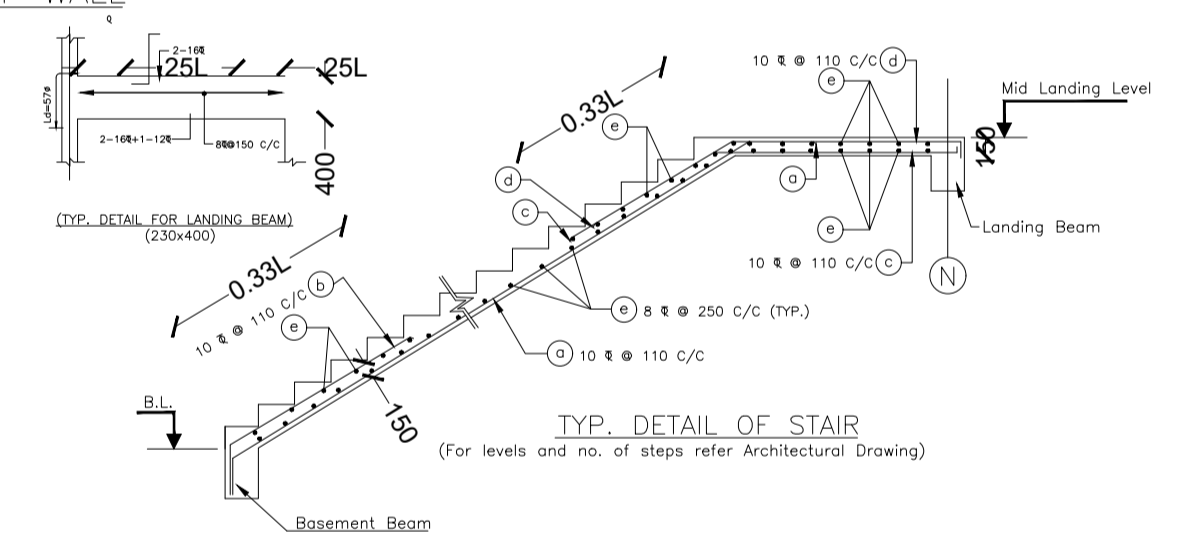
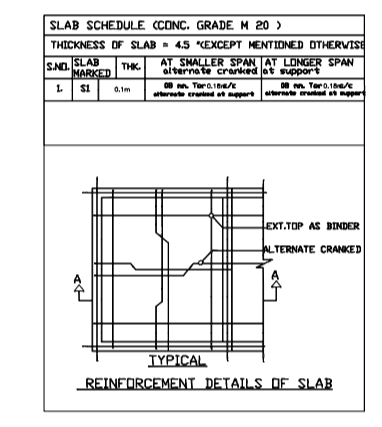
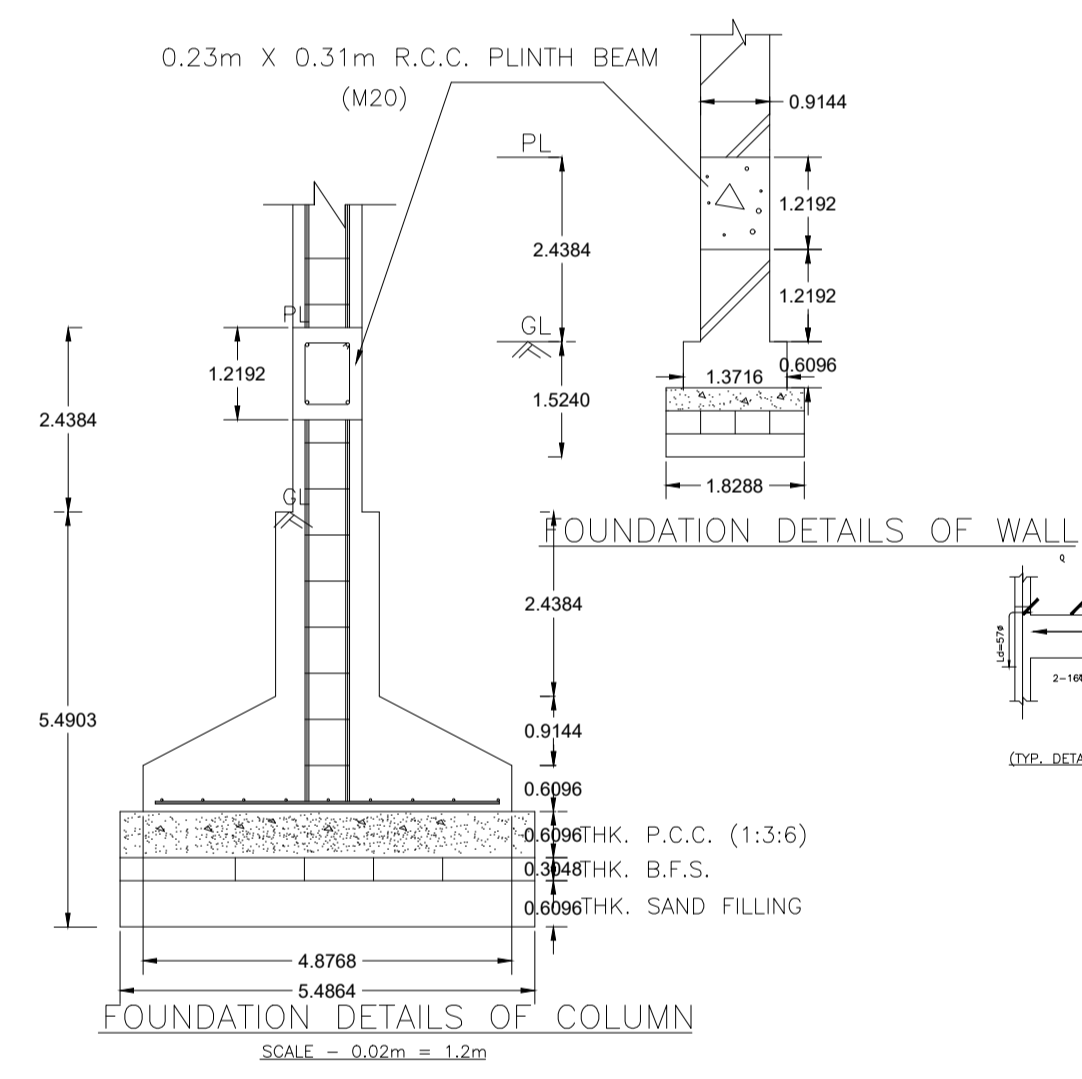
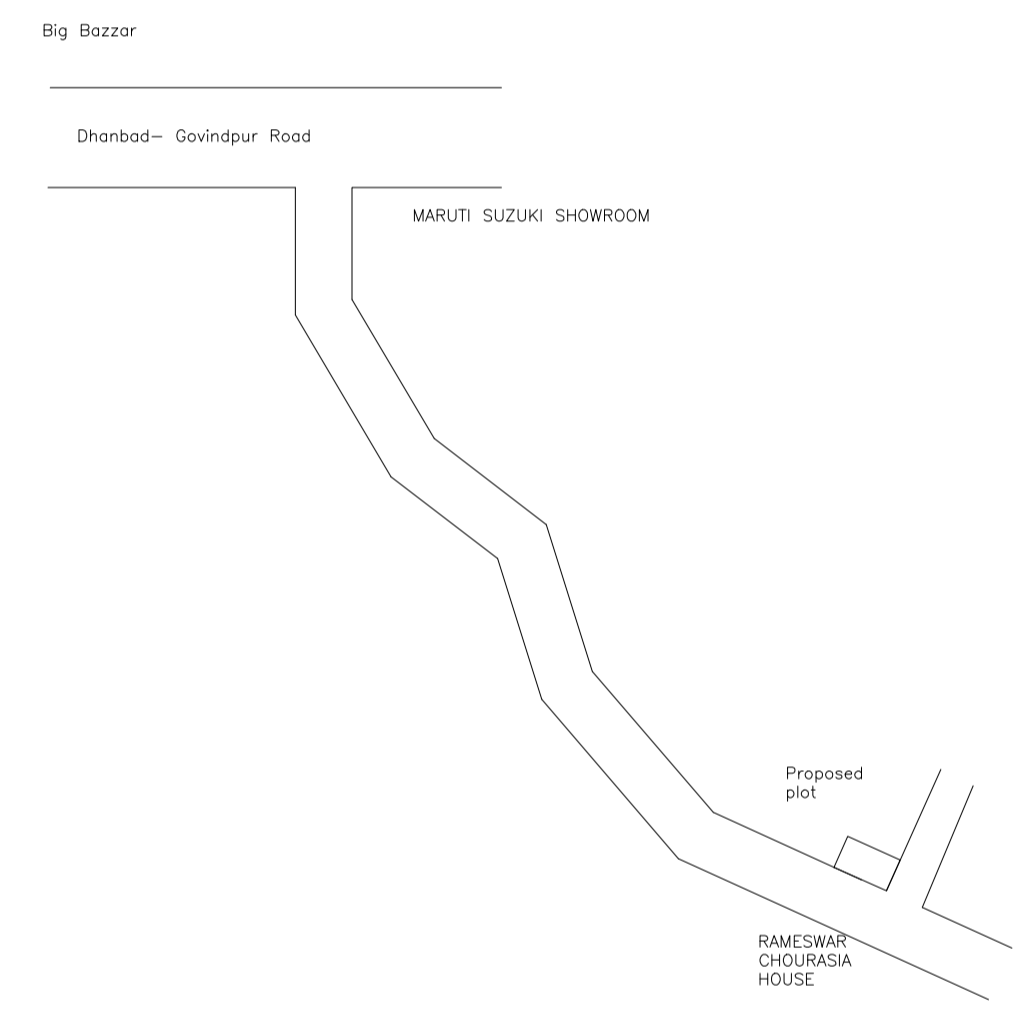

LTP NAME AND SIGNATURE	STRUCTURAL ENG'S NAME AND SIGNATURE	BUILDER NAME AND SIGNATURE	DIGITAL SIGNATURE
SUSHIL KUMAR DMC/ENG/0005/2016			