

Project Title :Vishvajet Kumar

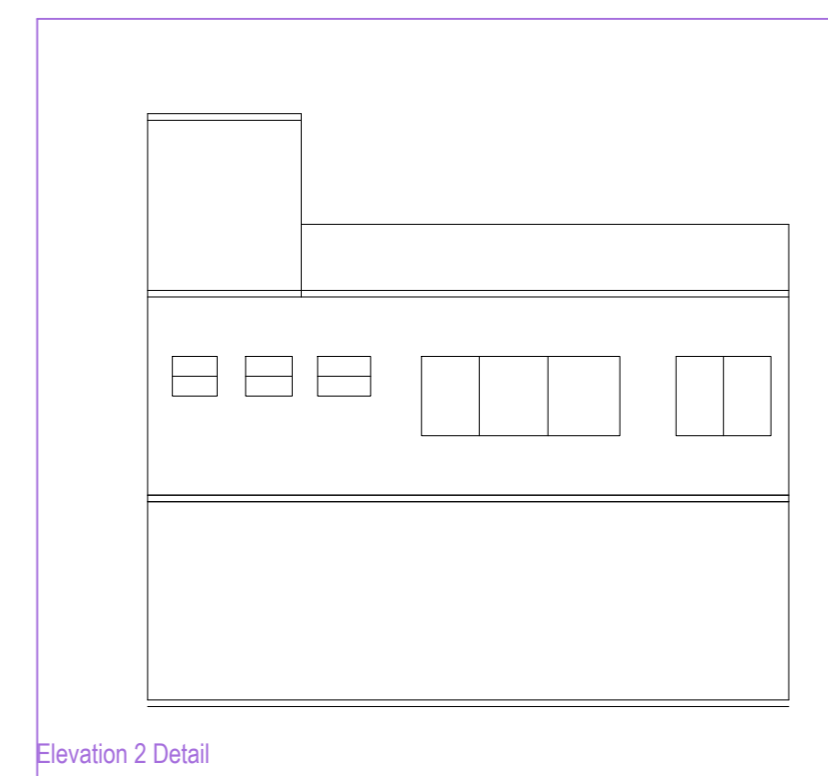
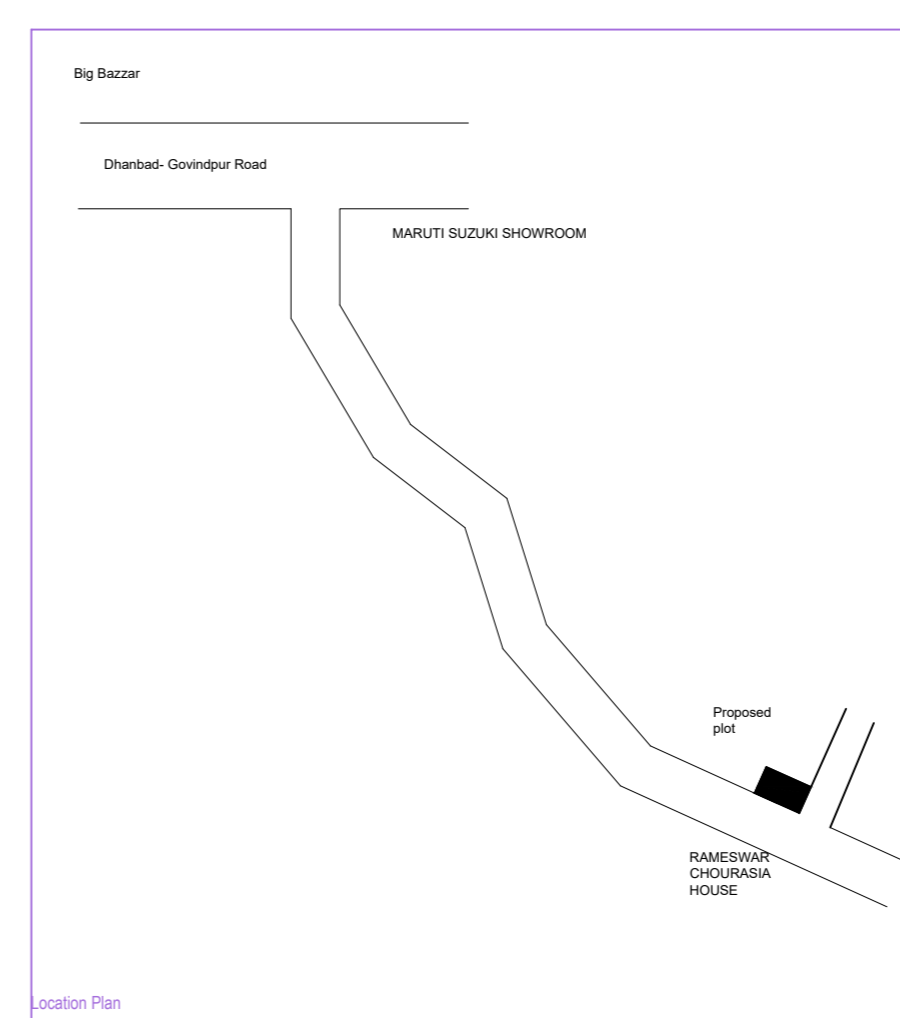
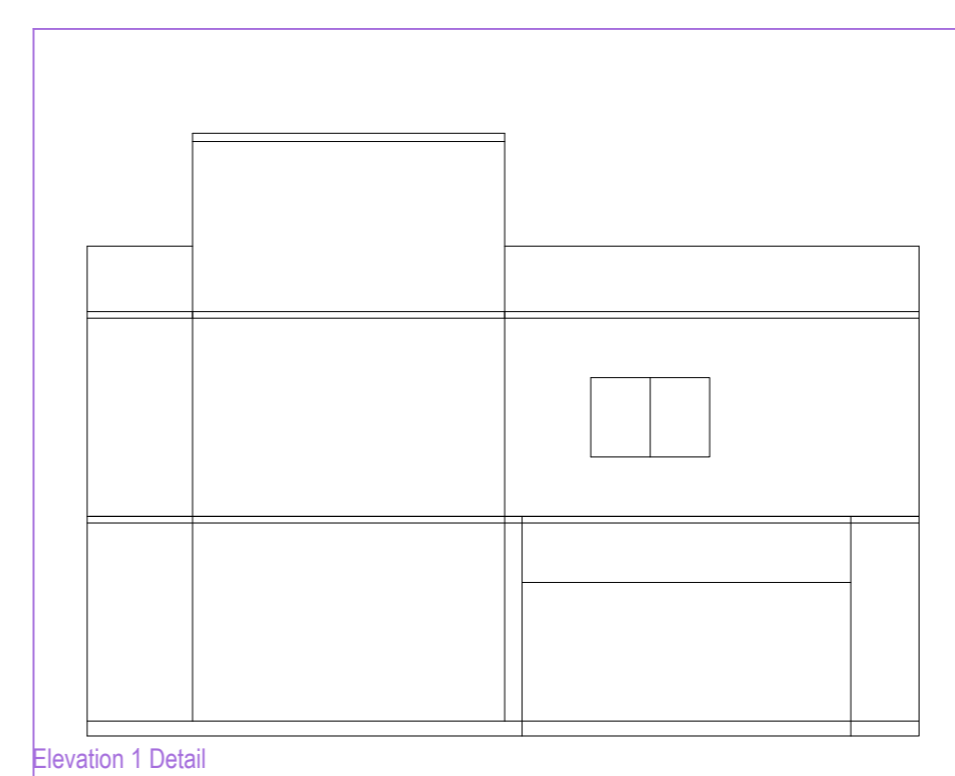
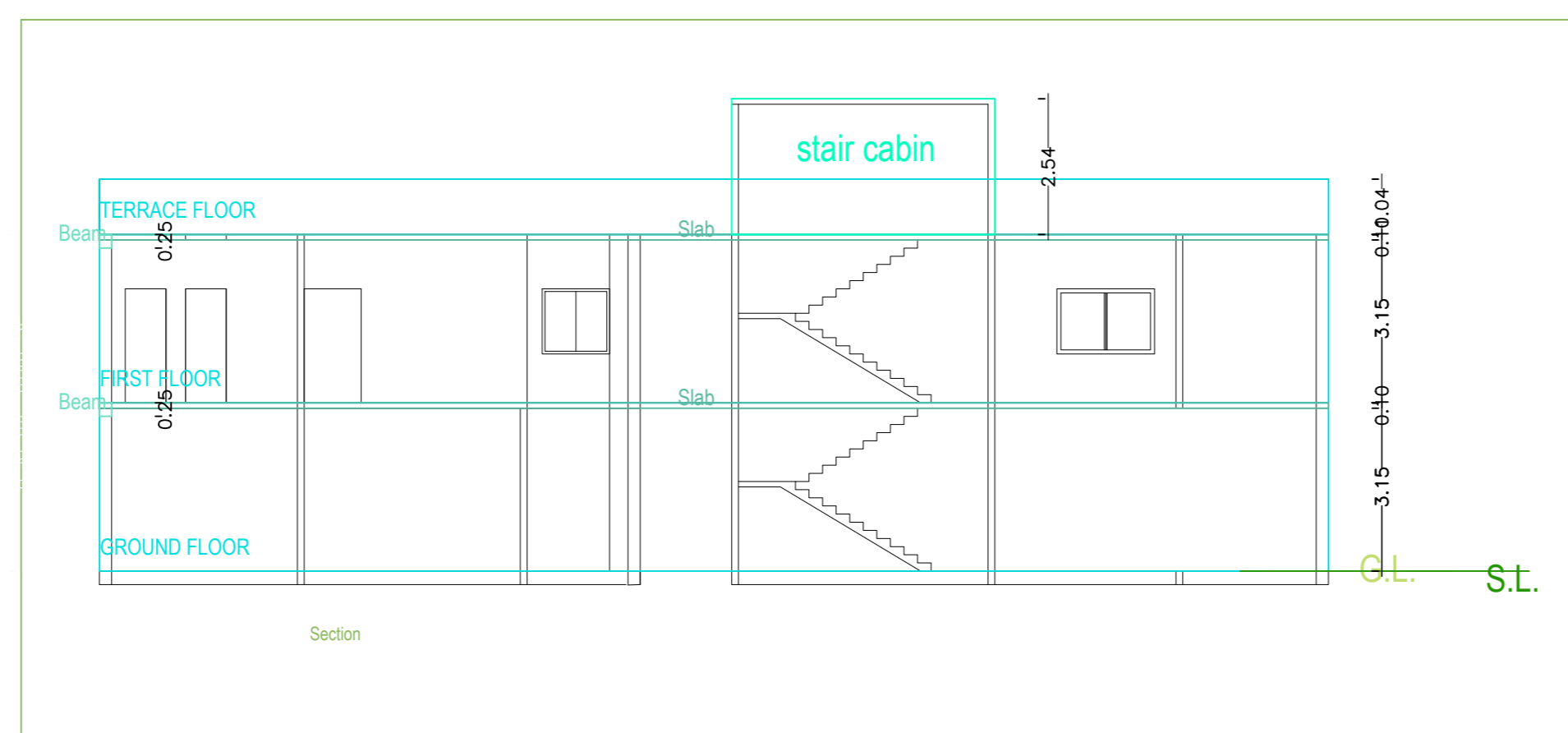
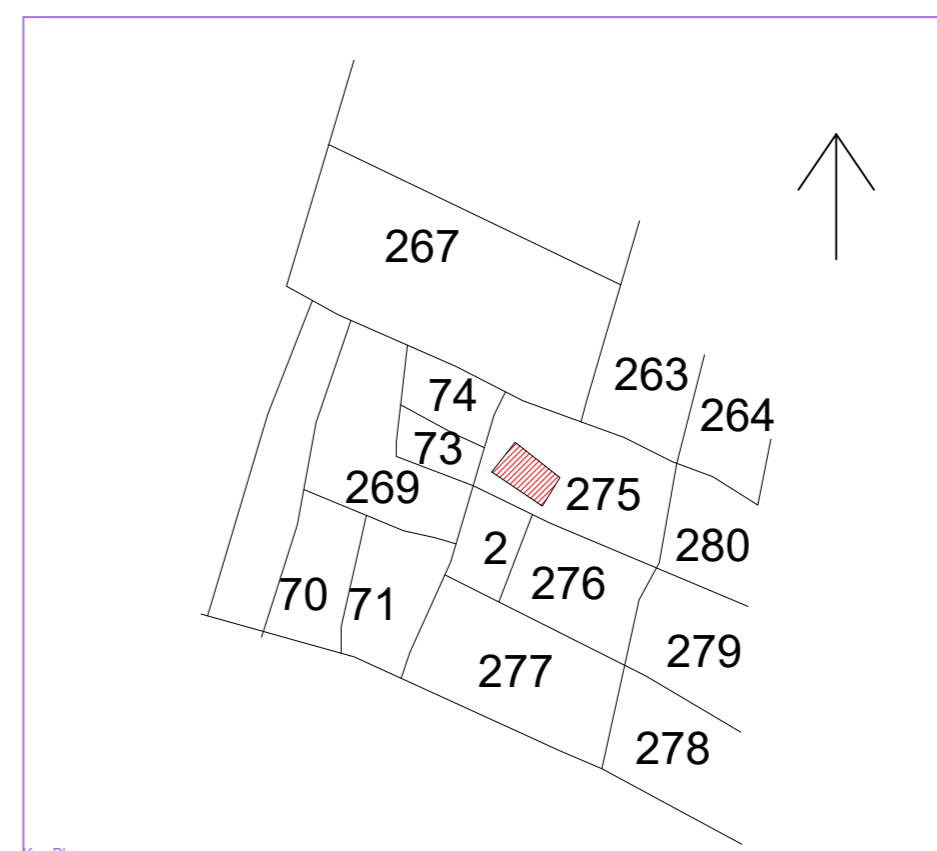
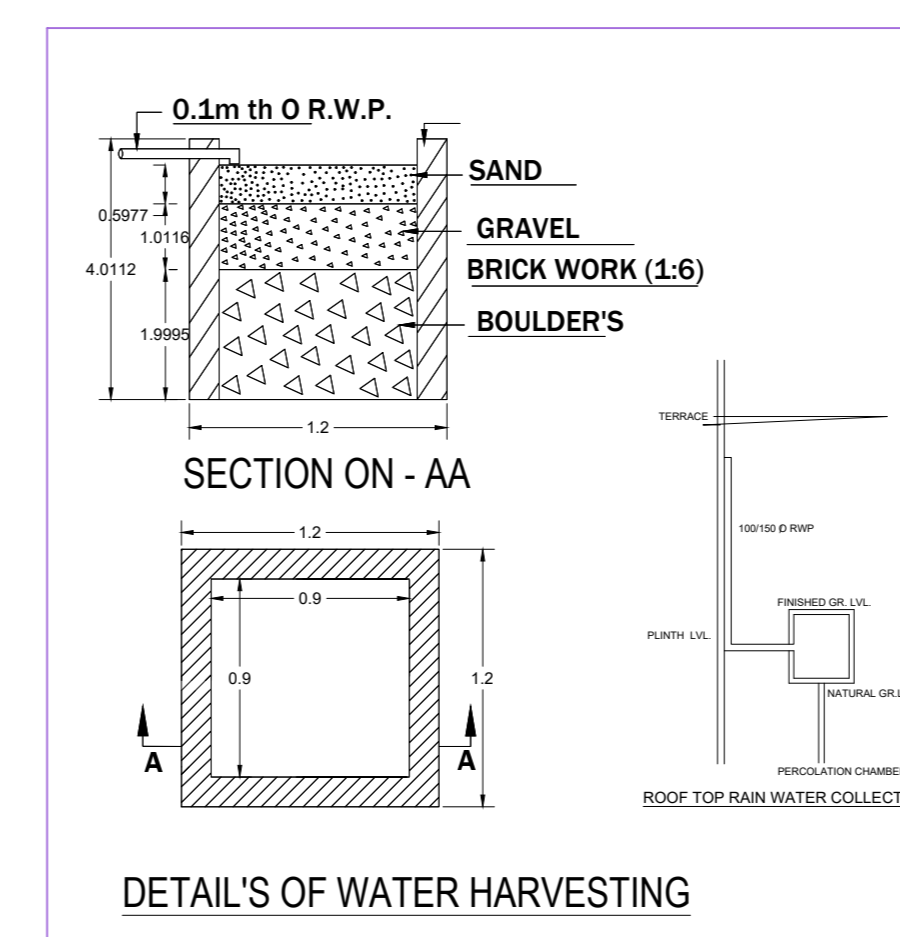
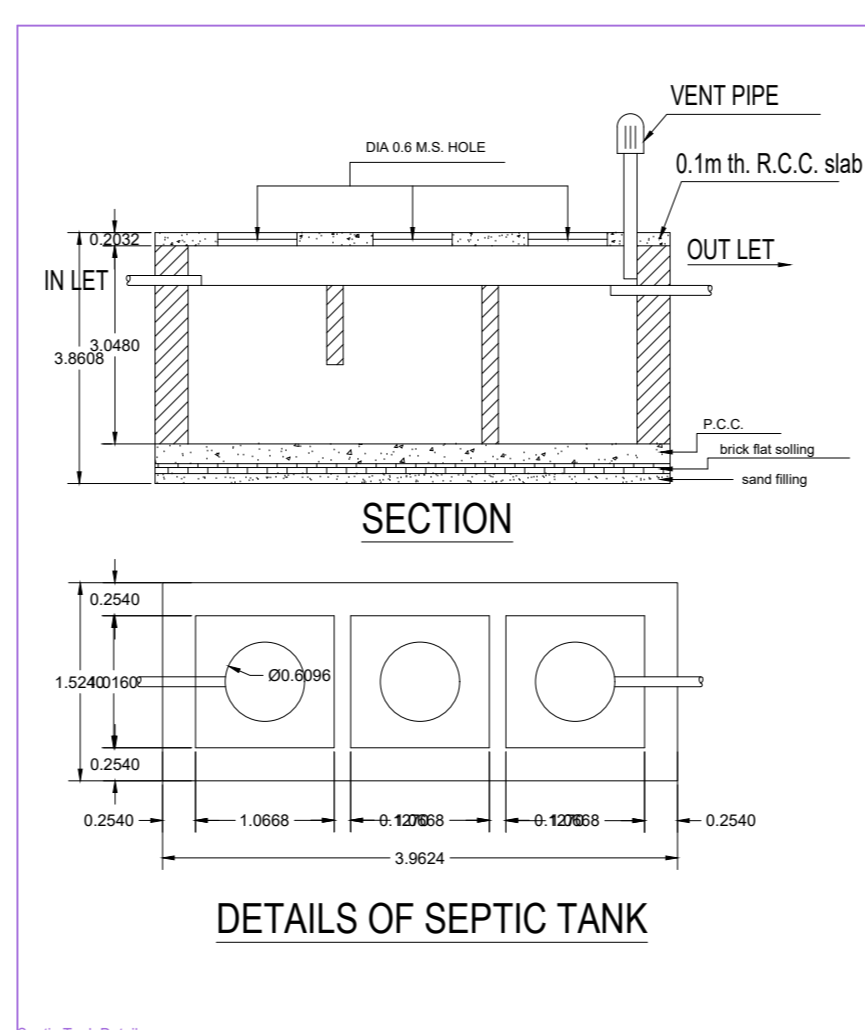
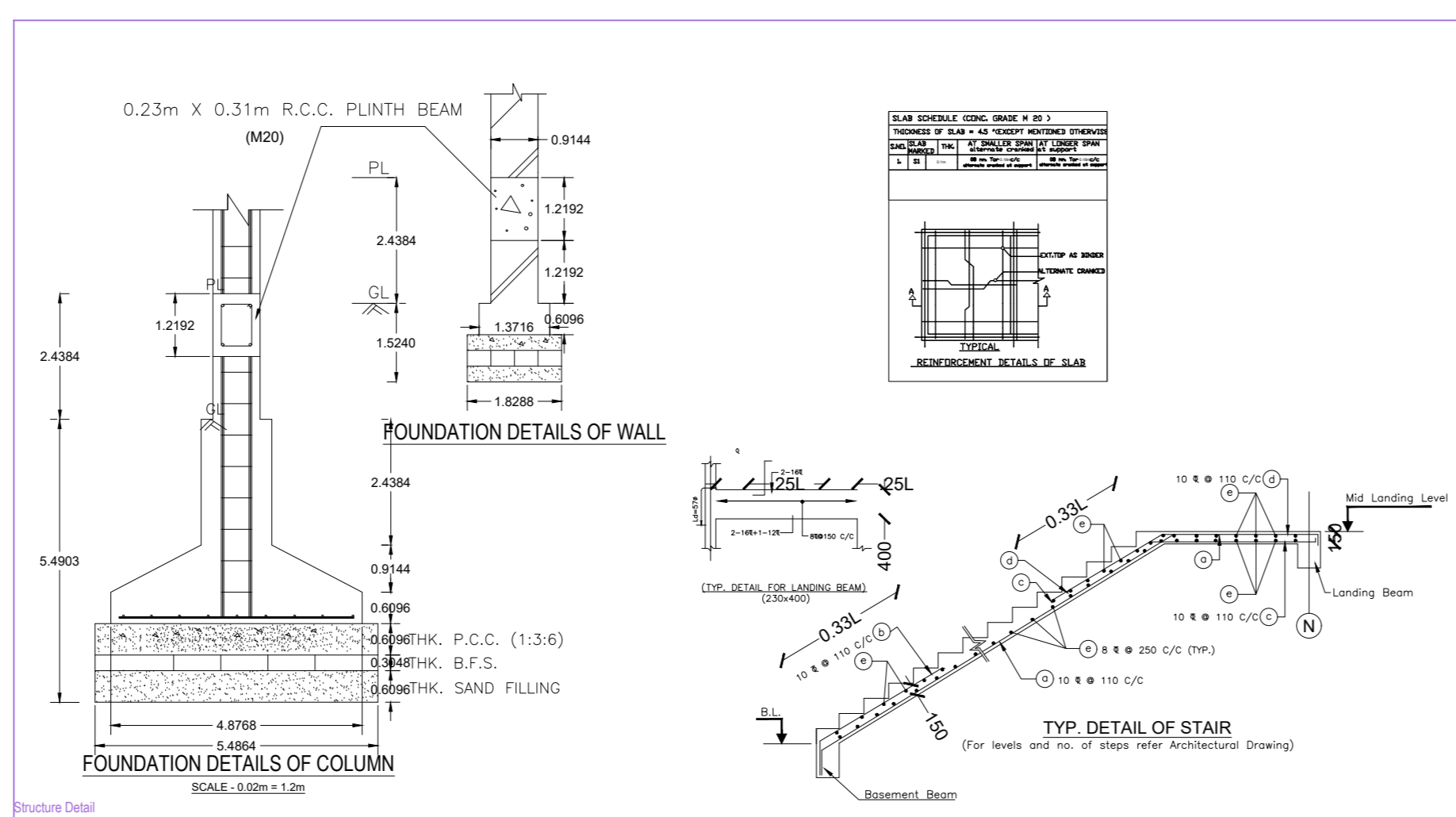

BRIEF SPECIFICATION

FOUNDATION - R.C.C. (1:1.5:3) Column footing foundation.
PLINTH - 12"th R.C.C. (1:1.5:3) all round on plinth level.
FLOORING - 1.5"th Marble. flooring over 3"th P.C.C. (1:3:6).
SUPER STRUCTURE - First class brick work in cement mortar (1:6).
SLAB, BEAM, stairs & LINTEL - All R.C.C. work (1:1.5:3).
WOOD WORK - All door & window frames of sal wood.
PLASTERING - 12mm cement plaster (1:6) both side.

SCHEDULE

D1 - 1.07 X 2.13	W - 0.9 x 1.22
D2 - 0.9 X 2.13	W1 - 1.22 x 1.22
D3 - 0.76 x 2.13	W2 - 1.5 x 1.22
CG - 1.22 x 2.13	V - 0.61 x 0.61

DETAILS OF AREA

1) LAND AREA	>	200.20 SQM
2) GROUND FLOOR AREA	>	112.29 SQM
3) FIRST FLOOR AREA	>	112.29 SQM
4) COVERED AREA	>	224.58 SQM
5) % OF PLINTH AREA	>	56.08 %
6) F.A.R	>	1.12

TITLE OF DRAWING

PROPOSED RESIDENTIAL BUILDING PLAN OF SRI. VISHVAJEET KUMAR S/O SRI. RAJEND KUMAR SINGH UNDER PLOT NO. 274/251 NEW MARIY, WPA & M33 (REVISED) UNDER WADA KOLKATA (12) IN THE DISTRICT OF DWARAKA

Building -A (1)

Floor Name	Total Built Up Area (Sq.m)	Proposed FAR Area (Sq.m)	Total FAR Area (Sq.m)	Terr (No.)
Ground Floor	112.29	112.29	112.29	01
First Floor	112.29	112.29	112.29	00
Terrace Floor	0.00	0.00	0.00	00
Total	224.58	224.58	224.58	01
Total Number of Same Buildings	1			
Total	224.58	224.58	224.58	01

SCHEDULE OF JOINERY:

BUILDING NAME	NAME	LENGTH	HEIGHT	NO
A(1)	01	0.76	2.10	04
A(1)	02	0.90	2.10	00
A(1)	01	0.90	2.10	01
A(1)	03	1.07	2.10	04
A(1)	04	3.97	2.10	01
Total				12

SCHEDULE OF JOINERY:

BUILDING NAME	NAME	LENGTH	HEIGHT	NO
A(1)	01	0.80	1.00	03
A(1)	02	1.20	1.20	01
A(1)	02	1.50	1.20	01
A(1)	01	2.20	1.20	01
Total				16

UnB/UA Table for Building A (1)

FLOOR	Name	UnB/UA Type	UnB/UA Area	Carpet Area	No. of Rooms	No. of Terrace
GROUND FLOOR PLAN	01(1)	FLAT	224.58	224.54	5	1
Total			224.58	224.54	13	1

AREA STATEMENT: DWARAKA MUNICIPAL CORPORATION

VERSION NO. 1.0.28
 VERSION DATE: 10/10/2020

PROJECT DETAIL:
 Project No. - Residential
 Plot Size - Residential
 Region - DWARAKA URBAN LOCAL BODIES
 Plot Size - Bungalow/Dwelling / Non Apartment
 District - DWARAKA
 Land Use Zone - Residential
 Application Type - General Proposal
 Adjoining Road Width -
 Project Type - Building Permission
 Plot No. -
 Nature of Development - New
 Proposed Survey No./Survey No. -
 Location - Old Area
 Thana No. -
 Sub Location - 148
 Holding No. -
 Village/Moza Name -
 Khata No. -
 Ward No. -
 North -
 Road/Street -
 South -
 East -
 West -

AREA DETAILS:

AREA OF PLOT (Minimum)	(A)	SQ.MT
NET PLOT AREA (Gross Plot Area)	(A-Deductions)	197.18
- Deduction from Gross Plot area	(A-Deductions)	197.18
Deduction for Reserve Plot Area (Type Green Plot Area)		
Gross Area		6.42
Total		197.18
Below Plot Area (Net Plot Area)	(A-Deductions)	197.18
Recreational/Amenity space		
Plot Area for Coverage (Net Plot Area)	(A-Deductions)	197.18
Plot Area for FSI (Net Plot Area + Road/Watering Area)	(A-Deductions)	197.18
COVERAGE CHECK		
Proposed Coverage Area (56.95 %)		112.29
FAR CHECK		
Proposed Area of FAR		224.58
Total Area of FAR		224.58
BUILT UP AREA CHECK		
Total Proposed Builtup Area		224.58
PROJECT ENGINEER/SUPERVISOR (Project)		OWNER

COLOR INDEX

Color Index:

Color	Index
Red	1
Green	2
Blue	3
Yellow	4

MARGIN DETAIL:

Building/ Wing	Road Name	Front Margin	Rear Margin	Side Margin	Setback Margin
A(1)	4.57 m wide road	2.01	1.54	0.91	0.91

FAR & Tenement Details (Table 4c-1)

Building	No. of Same Bldg	Total Built Up Area (Sq.m)	Proposed FAR Area (Sq.m)	Total FAR Area (Sq.m)	Terr (No.)
A(1)	1	224.58	224.58	224.58	01
Grand Total	1	224.58	224.58	224.58	01