

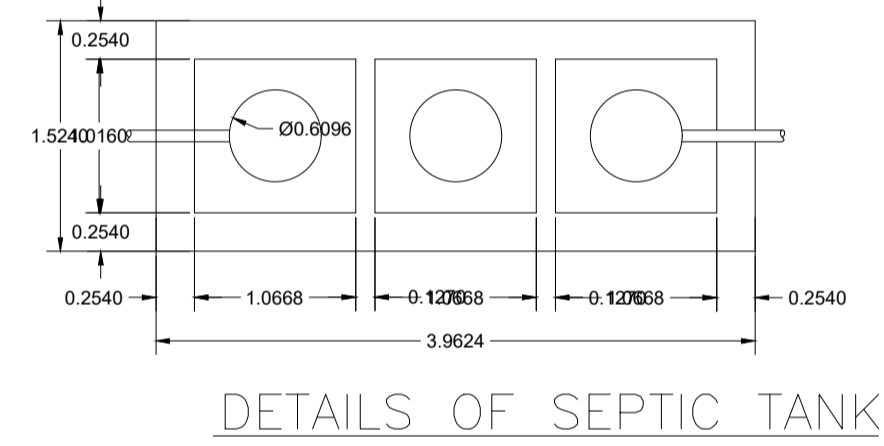

Proposal Basic Information	
Proposal File No.	DMC/BP/0142/W23/2021
Owner Name	Gopal Singh
Khata No	22 ( NEW 11)
Plot No	85 ( New 77)
Village Name	Amaghata
Use	Residential
SubUse	Bungalow/ Dwelling / Non Apartment

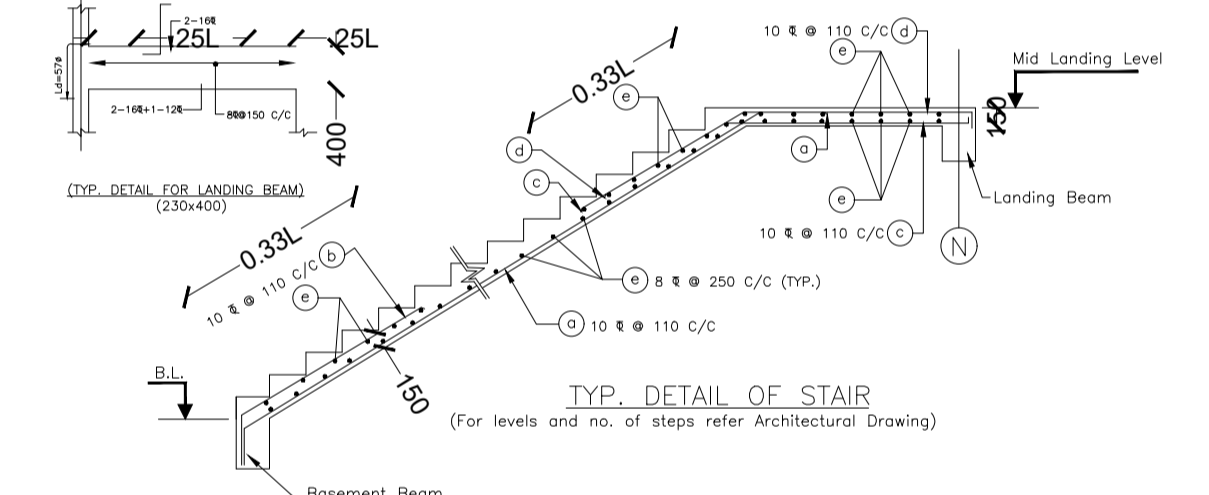

DETAIL'S OF WATER HARVESTING

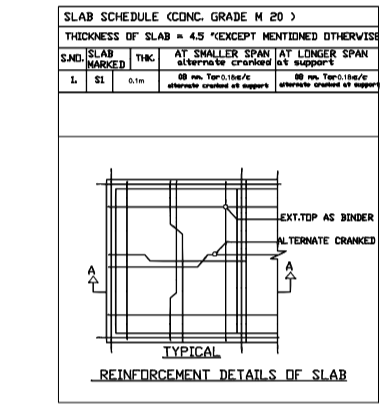
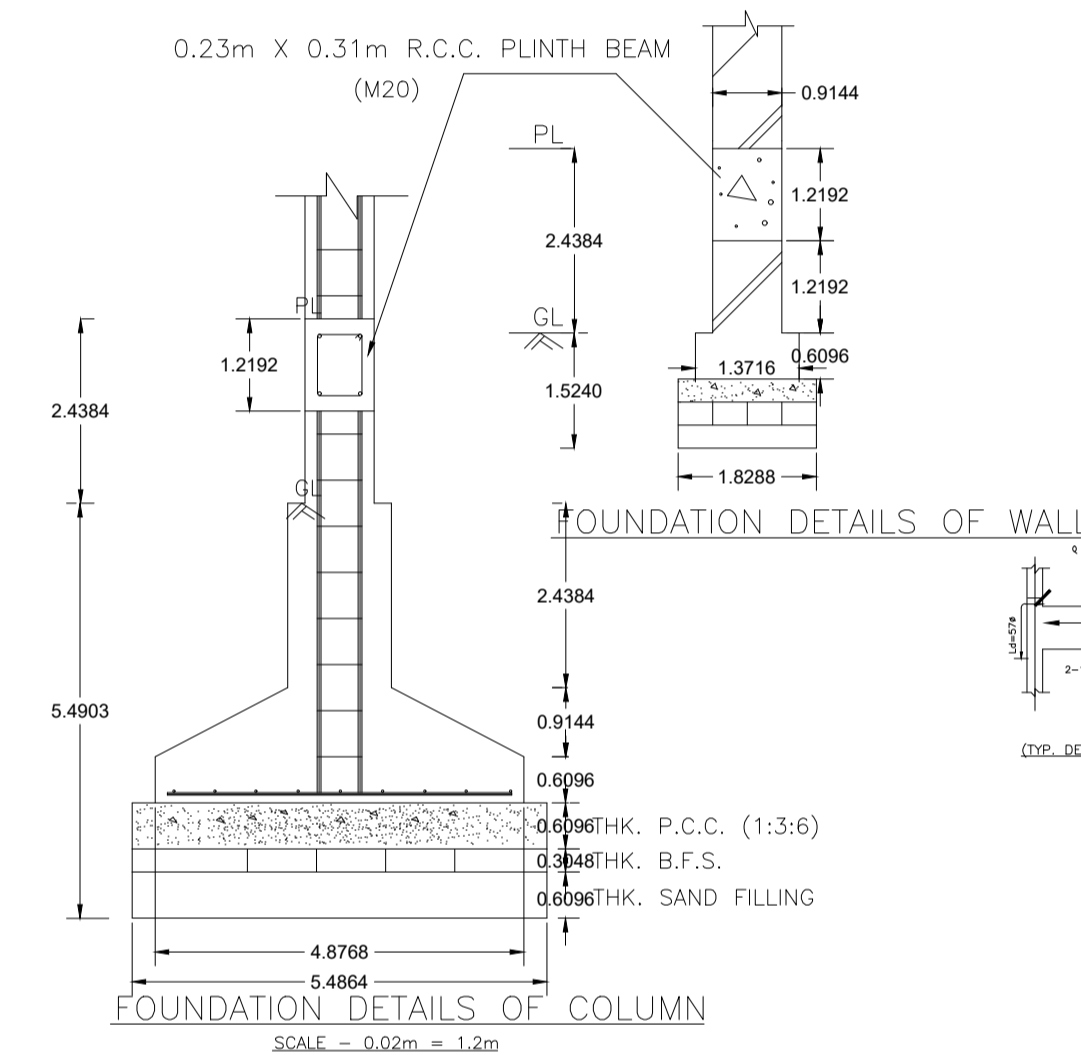
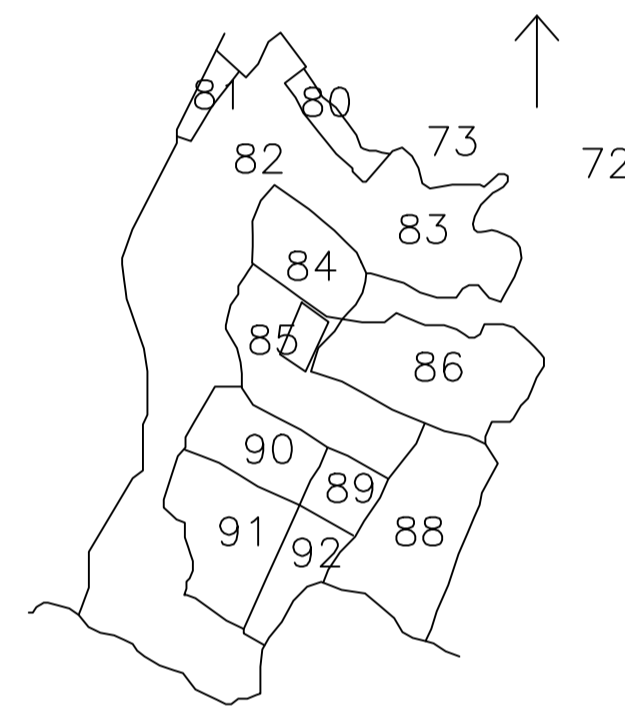
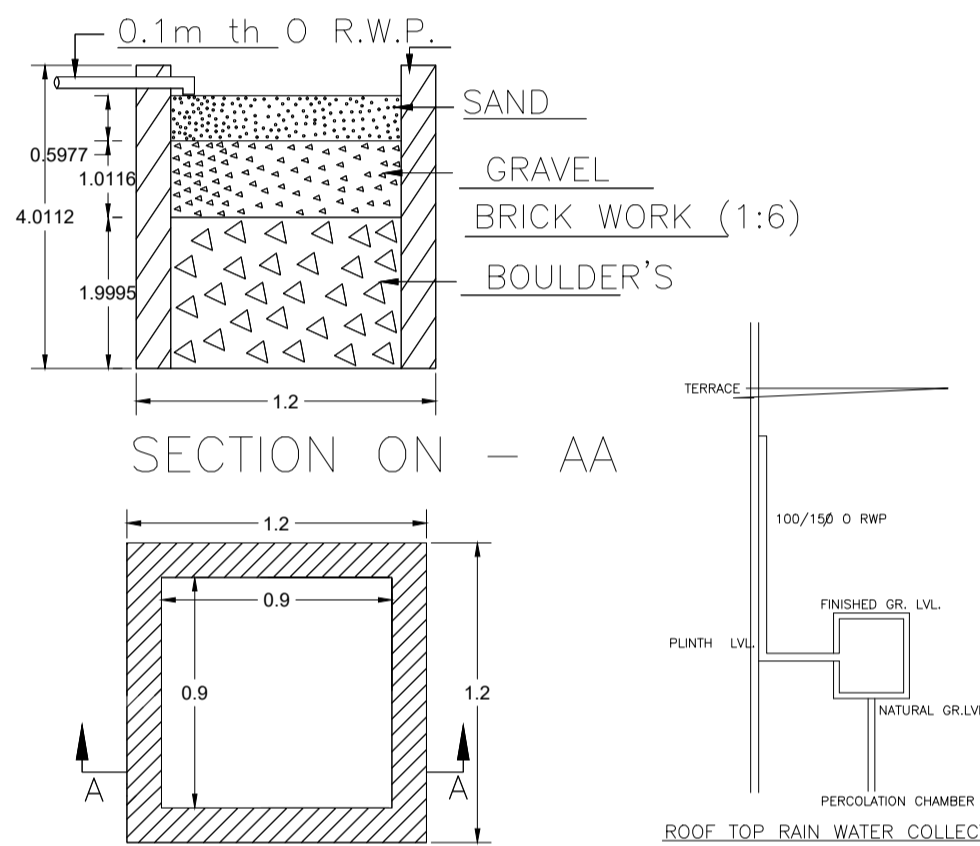
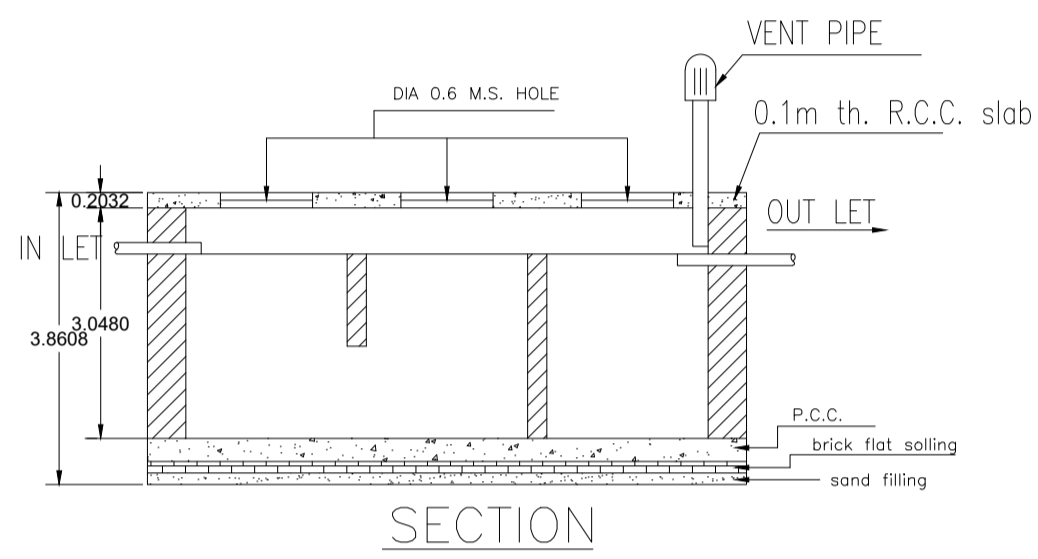
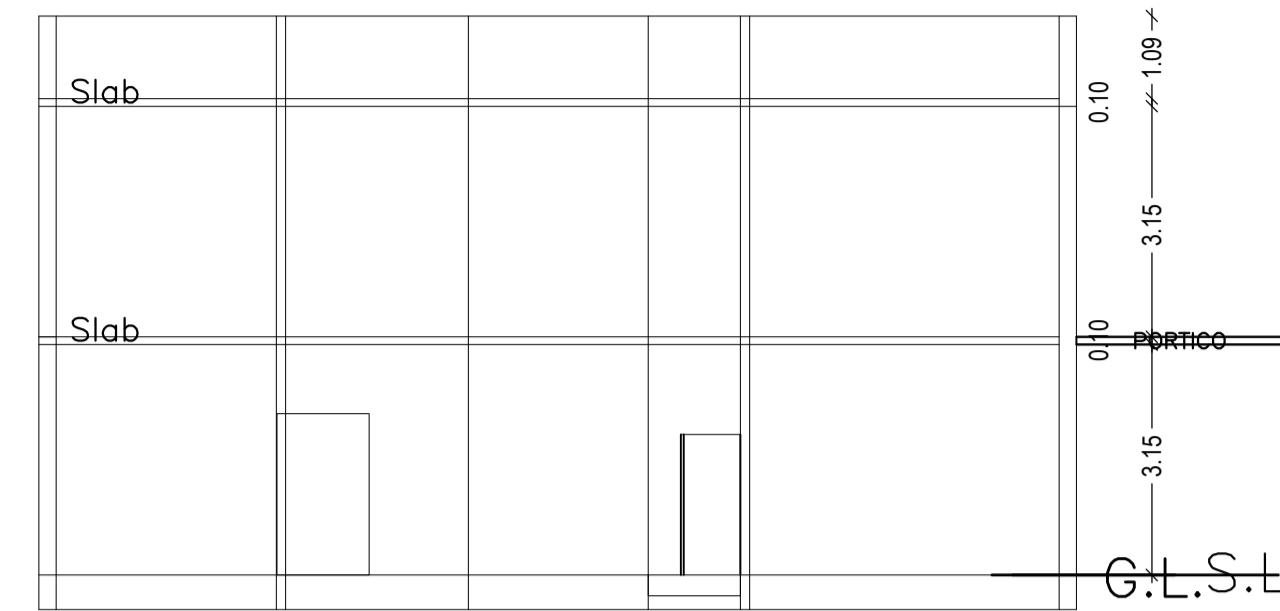
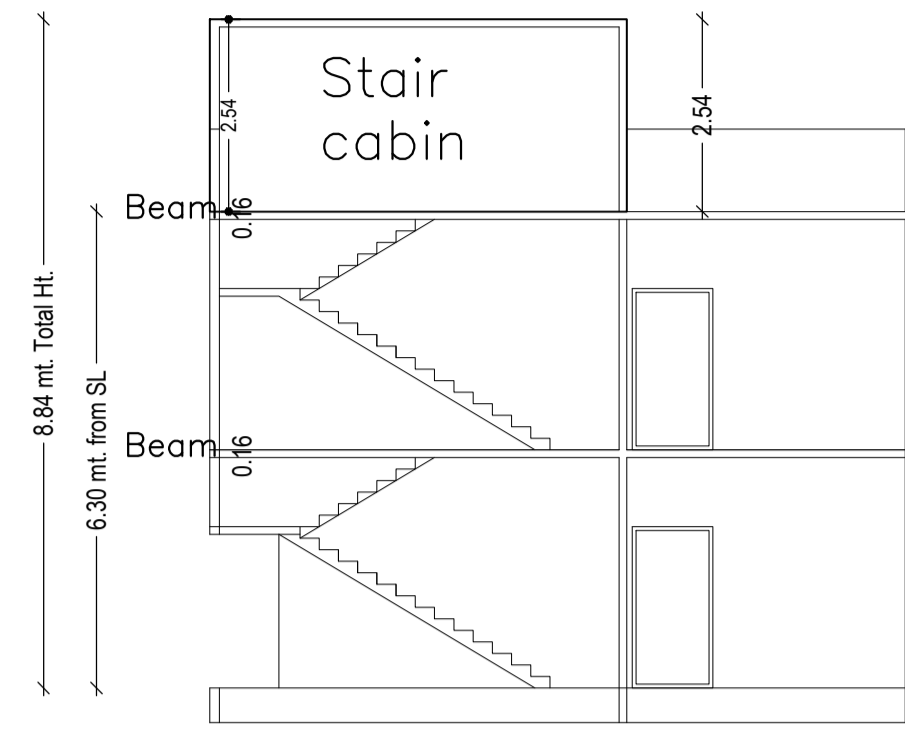
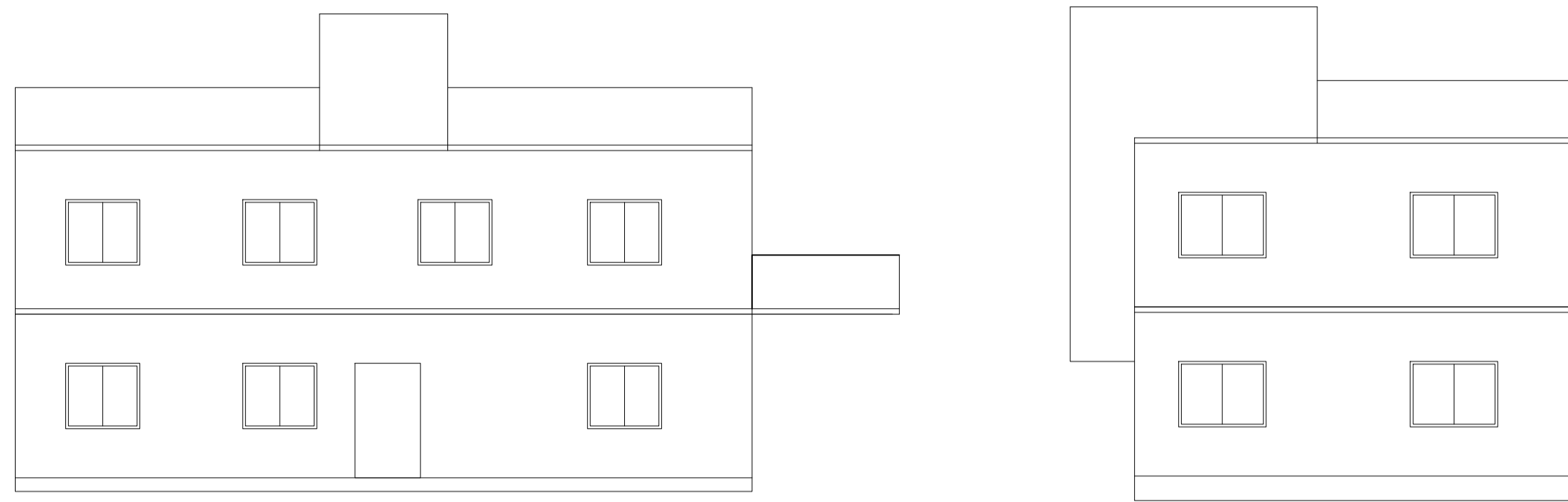
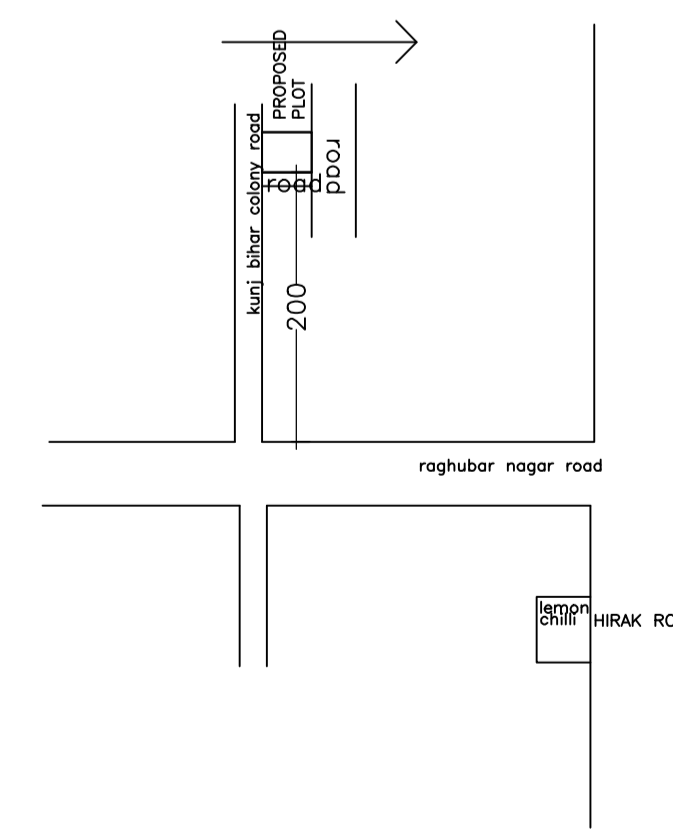
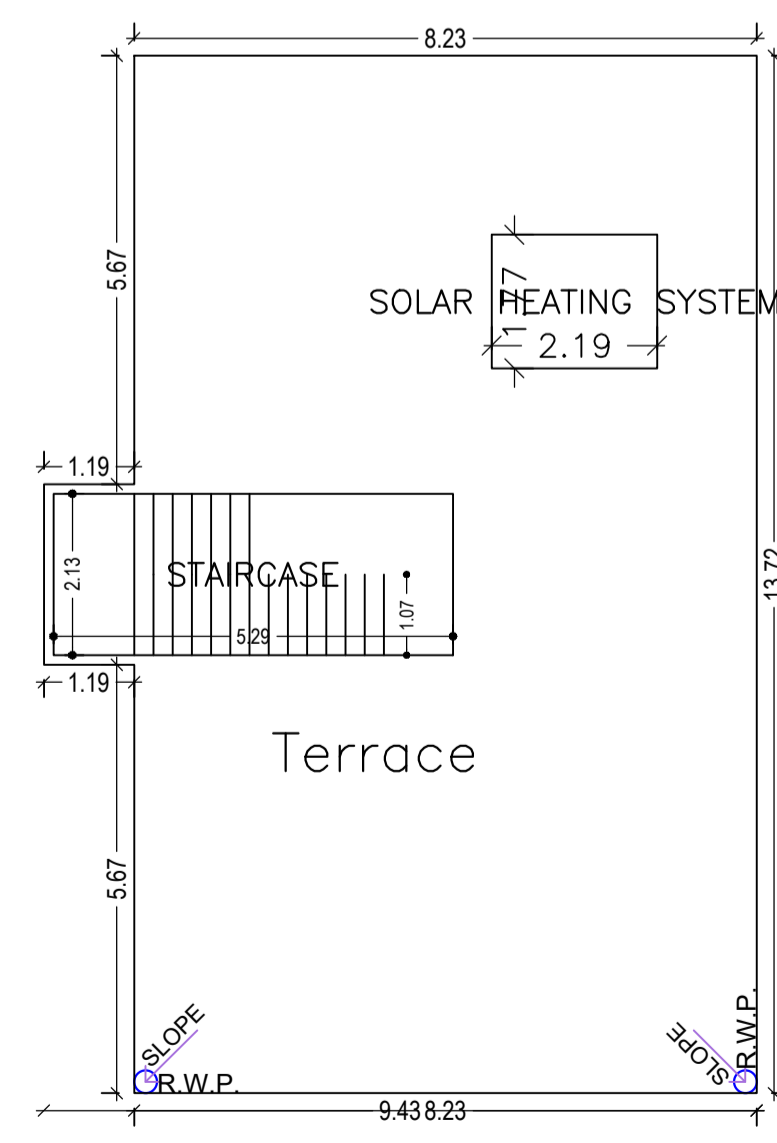
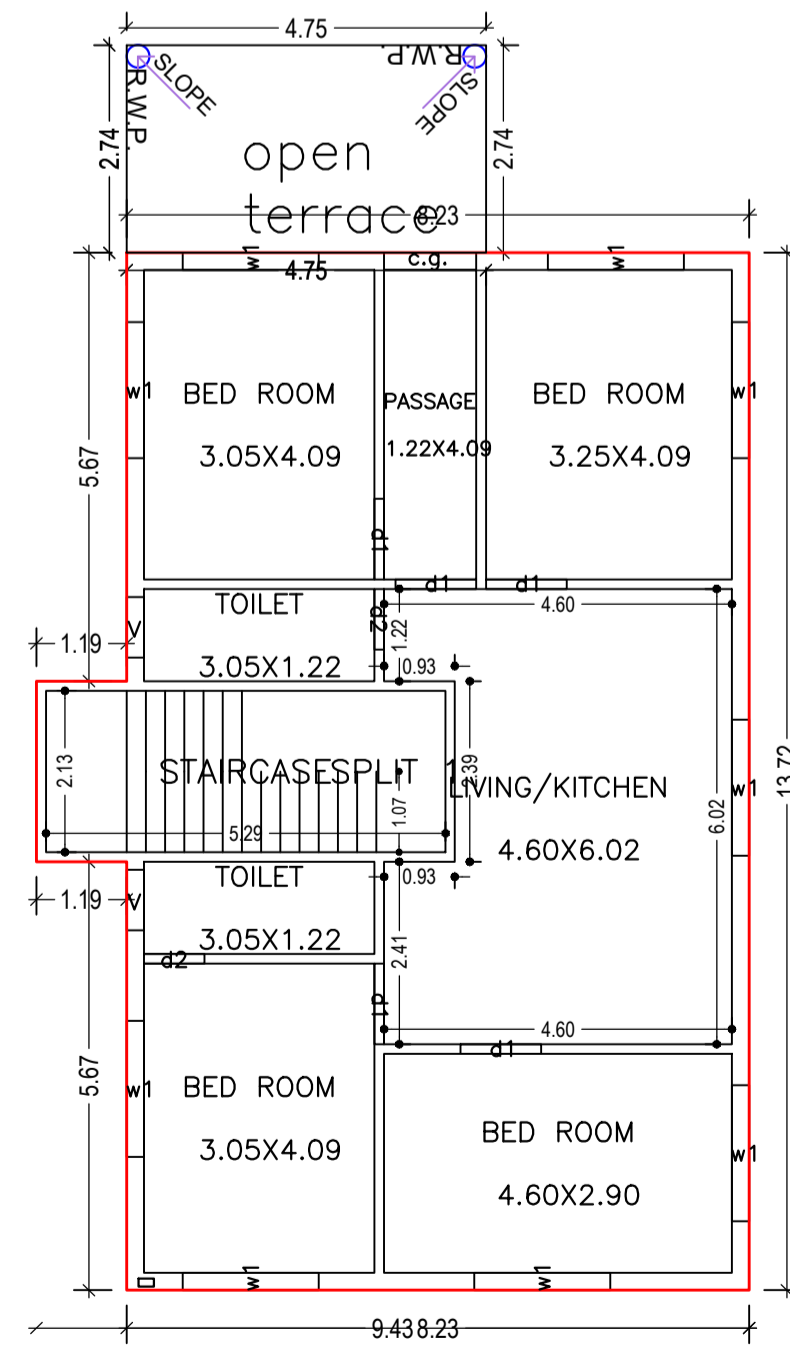
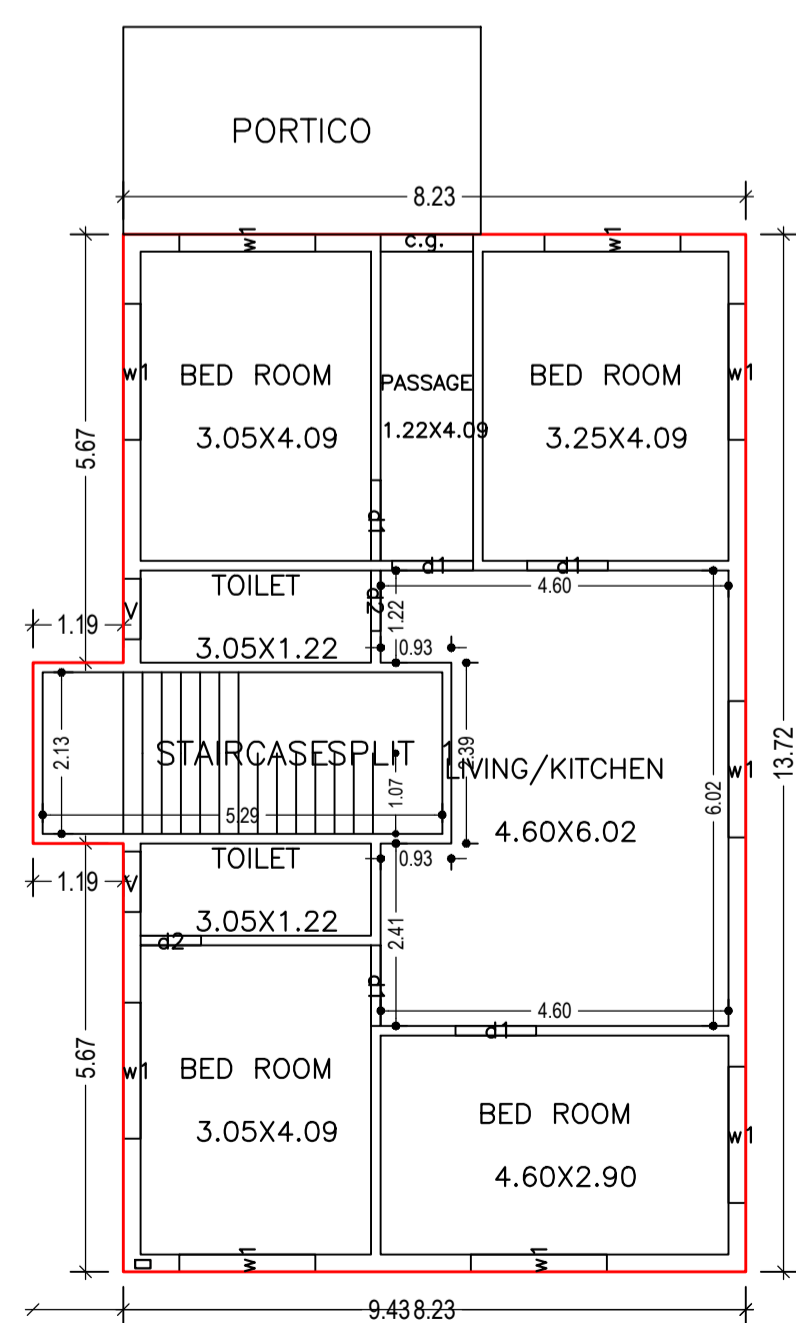

LTP NAME AND SIGNATURE	STRUCTURAL ENG'S NAME AND SIGNATURE	BUILDER NAME AND SIGNATURE	DIGITAL SIGNATURE
SUSHIL KUMAR DMC/ENG/0005/2016			