

Proposal Basic Information	
Proposal File No.	DMC/BP/0166/W21/2021
Owner Name	(1) Sri SANJAY KUMAR GUPTA AND Smt. MAMTA DEVI
Khata No	33
Plot No	582
Village Name	Dhaiya
Use	Residential
SubUse	Bungalow/ Dwelling / Non Apartment

AREA STATEMENT		VERSION NO. : 1.0.61
DHANBAD MUNICIPAL CORPORATION		VERSION DATE: 16/10/2020
PROJECT DETAIL:		
Region: JHARKHAND URBAN LOCAL BODIES	Plot Use: Residential	
District: DHANBAD	Plot SubUse: Bungalow/ Dwelling / Non Apartment	
Authority: DHANBAD MUNICIPAL CORPORATION	PlotNearbyReligiousStructure: NA	
Inward No: DMC/BP/0166/W21/2021	Plot/SubPlot No: 582	
Application Type: General Proposal	North: Plot No. - RAMPARBESH SINGH	
Project Type: Building Permission	South: Plot No. - SANJAY KUMAR GUPTA	
Nature of Development: New	East: Plot No. - PLOT NO. 585	
Location of Development Area: Old Area	West: Road Width - 3.88	
AREA DETAILS:		
AREA OF PLOT (Minimum)	(A)	SQ.MT. 406.22
Deduction for NetPlot Area		
Road Widening Area		0.63
Total		0.63
NET AREA OF PLOT(Gross Plot Area - Deduction from Gross Plot area)	(A-Deductions)	405.59
Deduction for Balance Plot Area(from Gross Plot Area)		
Road Widening Area		0.63
Common Plot		22.03
Total		22.66
BALANCE AREA OF PLOT(Net Plot Area - Recreational/Amenity spaces)	(A-Deductions)	383.56
PLOT AREA FOR COVERAGE(Net Plot Area)	(A-Deductions)	405.59
Plot Area for FAR (Net Plot Area + RoadWidening Area)	(A-Deductions)	405.59
COVERAGE CHECK		
Permissible Coverage area (60.00 %)		243.35
Proposed Coverage Area (28.38 %)		115.11
Total Prop. Coverage Area (28.38 %)		115.11
Balance coverage area (31.62 %)		128.24
FAR CHECK		
Perm. FAR Area (1.20)		486.71
Total Perm. FAR area		486.71
Residential FAR		230.22
Proposed FAR Area		230.22
Total Proposed FAR Area		230.22
Consumed FAR (Factor)		0.57
Balance FAR Area		256.49
BUILT UP AREA CHECK		
Total Proposed BuiltUp Area		230.22
ARCHITECT (Regd)	JITENDAR KUMAR	
ENGINEER (Regd)		
SUPERVISOR (Regd)		
OWNER (Regd)	(1) Sri SANJAY KUMAR GUPTA AND Smt. MAMTA DEVI	
DEVELOPMENT AUTHORITY		LOCAL BODY

Building USE/SUBUSE Details

Building Name	Building Use	Building SubUse	Building Structure
A (B)	Residential	Residential Bldg/Apartment	Non-Highrise

Building :A (B)

Floor Name	Total Built Up Area (Sq.mt.)	Proposed FAR Area (Sq.mt.) Res.	Total FAR Area (Sq.mt.)	Total Consumed Additional FAR Area (Sq.mt.)	Trmt (No.)
Ground Floor	115.11	115.11	115.11	115.11	01
First Floor	115.11	115.11	115.11	115.11	00
Terrace Floor	0.00	0.00	0.00	0.00	00
Total:	230.22	230.22	230.22	230.22	01
Total Number of Same Buildings :					
Total:	230.22	230.22	230.22	230.22	01

SCHEDULE OF DOOR:

BUILDING NAME	NAME	LENGTH	HEIGHT	NOS
A (B)	D	0.76	2.10	04
A (B)	D	0.91	2.10	02
A (B)	D	1.07	2.10	08
A (B)	D	1.11	2.10	02
A (B)	D	1.22	2.10	02

SCHEDULE OF WINDOW/VENTILATION:

BUILDING NAME	NAME	LENGTH	HEIGHT	NOS
A (B)	W	0.81	1.20	02
A (B)	W	0.84	1.20	02
A (B)	W	1.18	1.20	03
A (B)	W	1.40	1.20	02
A (B)	W	1.86	1.20	02
A (B)	W	1.89	1.20	02
A (B)	W	1.99	1.20	02
A (B)	W	2.08	1.20	02
A (B)	W	2.27	1.20	02
A (B)	W	2.35	1.20	02
A (B)	W	2.38	1.20	02
A (B)	W	2.59	1.20	02
A (B)	W	2.81	1.20	02

SITE PLAN

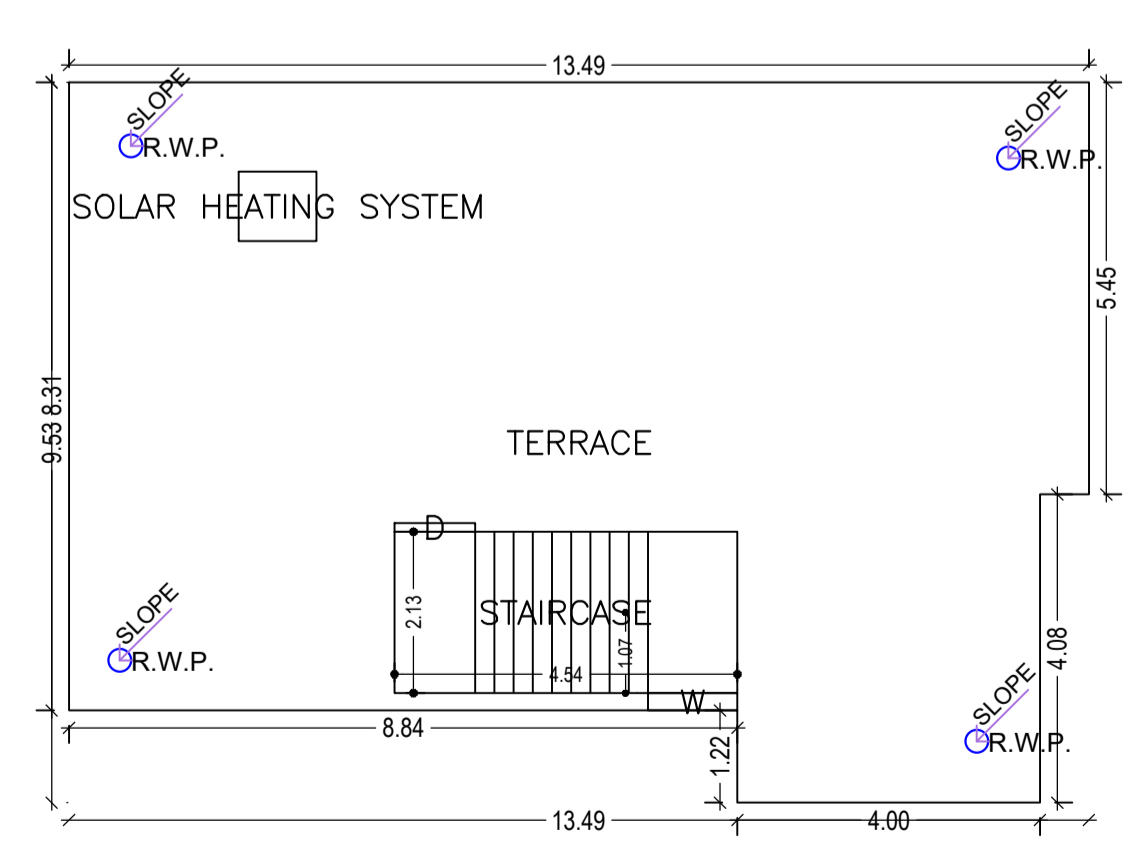
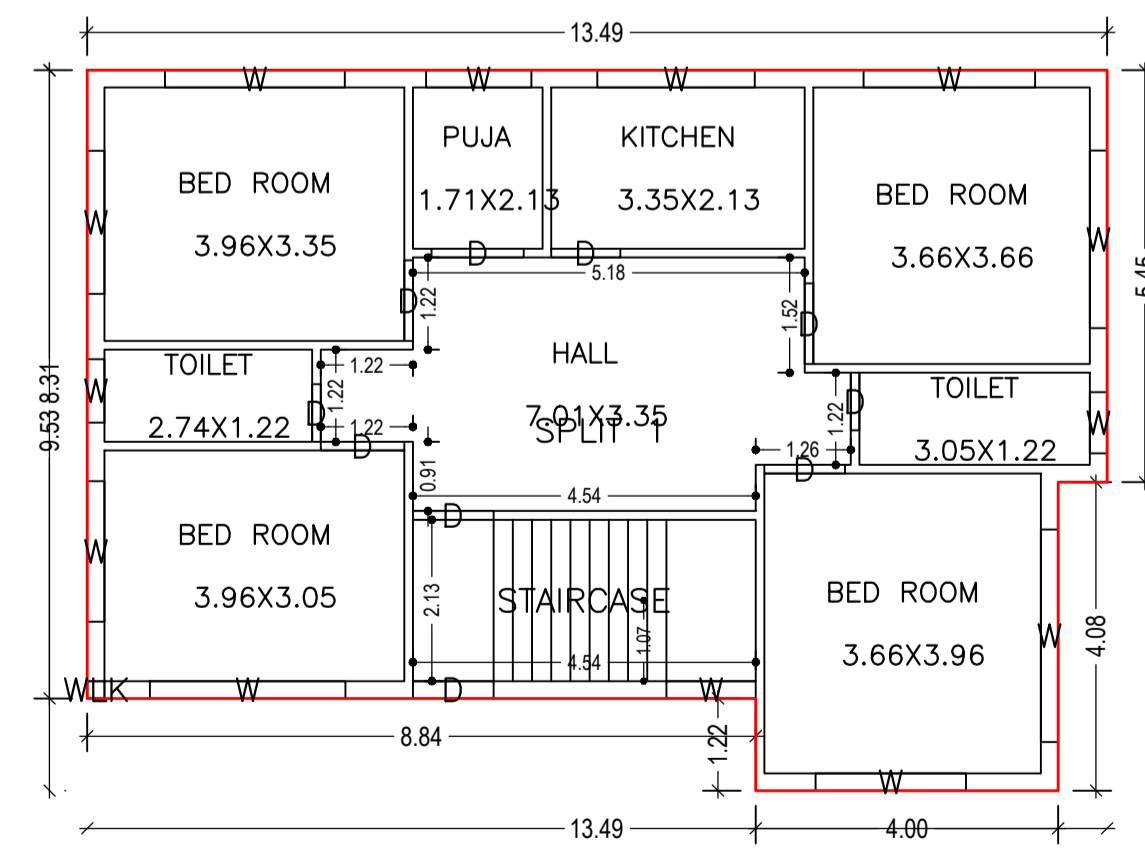
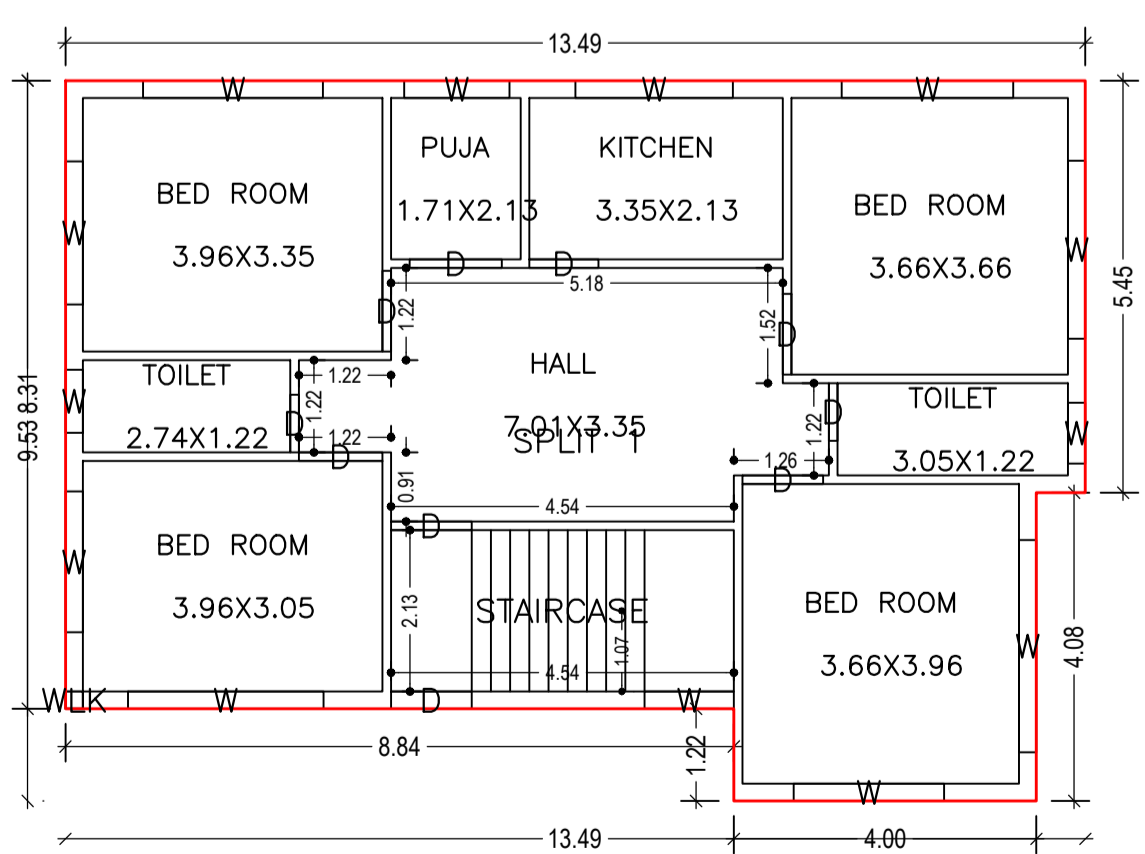

COLOR INDEX

PLOT BOUNDARY	Black
ABUTTING ROAD	Green
PROPOSED CONSTRUCTION	Red
COMMON PLOT	Yellow
ROAD WIDENING AREA	Blue
EXISTING (To be retained)	Light Blue
EXISTING (To be demolished)	Dark Blue

Buildingwise Floor FAR Details

Floor Name	Building Name A (B)		Total	
	Proposed Built Up Area (Sq.mt.)	Proposed FAR Area (Sq.mt.)	Total Proposed Built Up Area (Sq.mt.)	Total FAR Area (Sq.mt.)
Ground Floor	115.11	115.11	115.11	115.11
First Floor	115.11	115.11	115.11	115.11
Terrace Floor	0.00	0.00	0.00	0.00
Total :	230.22	230.22	230.22	230.22

FAR & Tenement Details (Table 4c-1)

Building	No. of Same Bldg	Total Built Up Area (Sq.mt.)	Proposed FAR Area (Sq.mt.) Res.	Total FAR Area (Sq.mt.)	Total Consumed Additional FAR Area (Sq.mt.)	Trmt (No.)
A (B)	1	230.22	230.22	230.22	230.22	01
Grand Total :	1	230.22	230.22	230.22	230.22	01

UnitBUA Table for Building :A (B)

FLOOR	Name	UnitBUA Type	UnitBUA Area	Carpet Area	No. of Rooms	No. of Tenement
GROUND FLOOR PLAN	SPLIT 1	FLAT	230.22	230.11	9	1
FIRST FLOOR PLAN	SPLIT 1	FLAT	0.00	0.00	9	0
Total:	-	-	230.22	230.11	18	1

LTP NAME AND SIGNATURE	STRUCTURAL ENG'S NAME AND SIGNATURE	BUILDER NAME AND SIGNATURE	DIGITAL SIGNATURE
JITENDAR KUMAR DMC/DFTMN/0006/2018			

Proposal Basic Information	
Proposal File No.	DMC/BP/0166/W21/2021
Owner Name	(1) Sri. SANJAY KUMAR GUPTA AND Smt. MAMTA DEVI
Khata No	33
Plot No	582
Village Name	Dhaiya
Use	Residential
SubUse	Bungalow/ Dwelling / Non Apartment

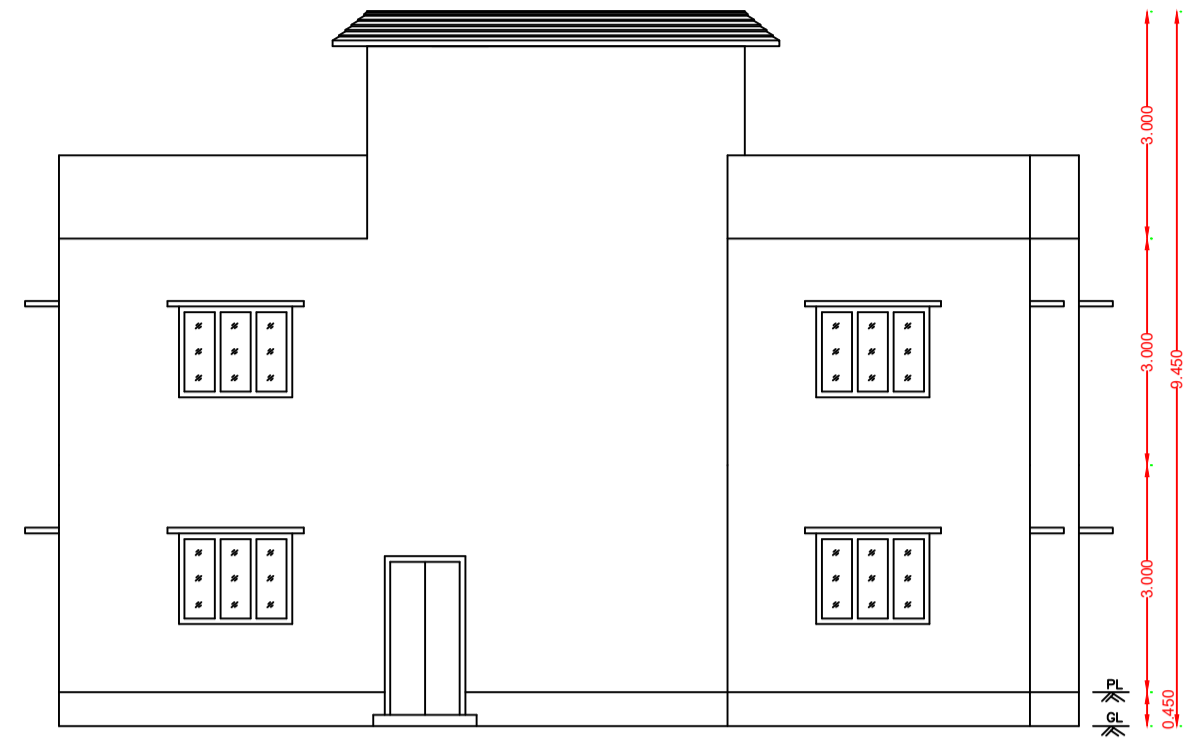

FRONT ELEVATION

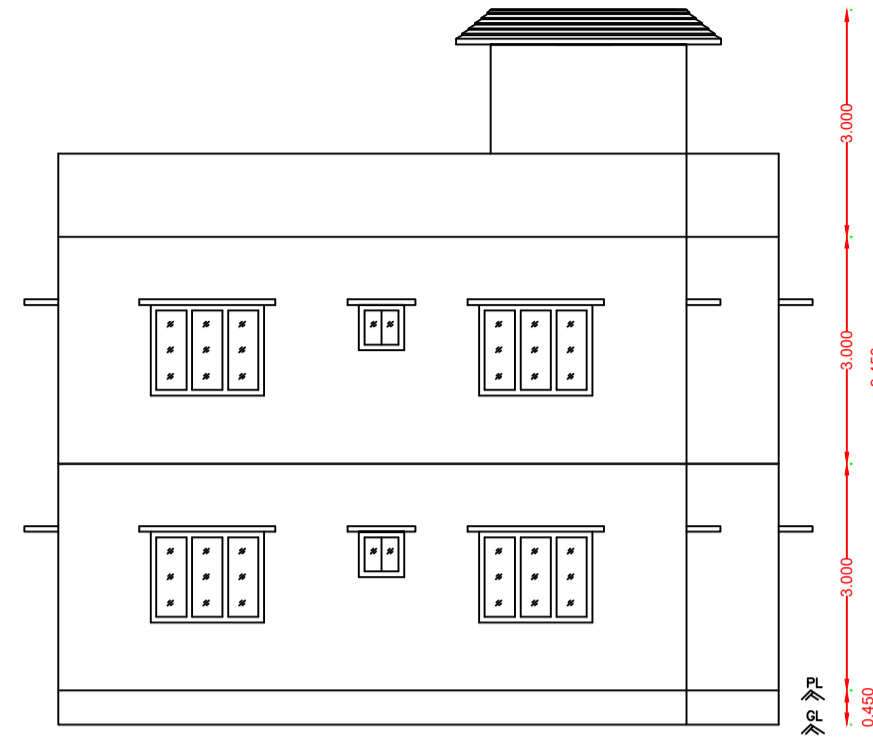

LEFT SIDE ELEVATION

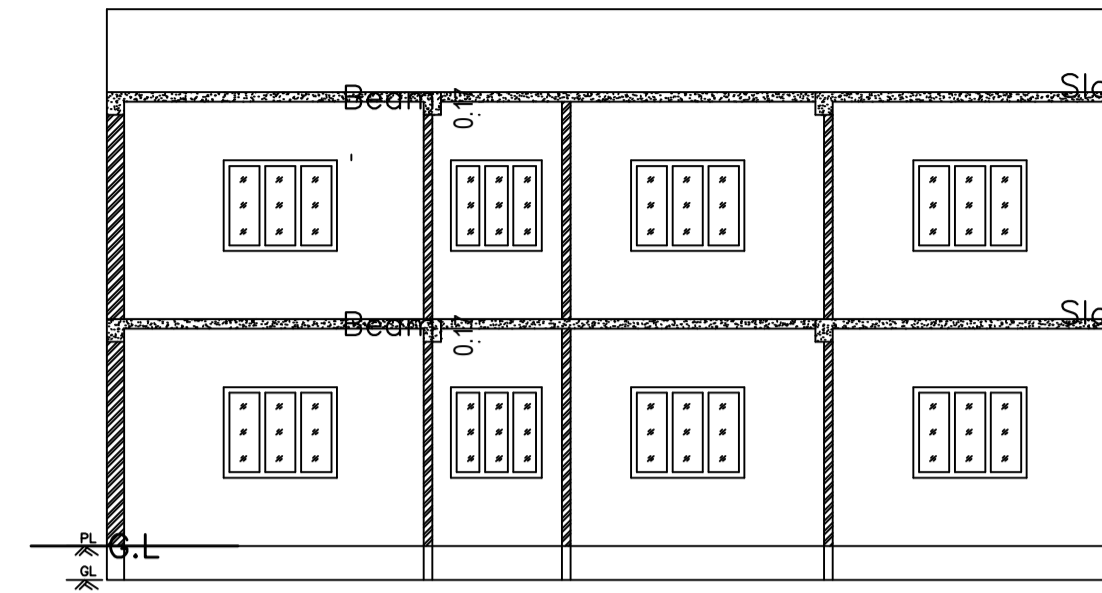

SECTION AT X-X

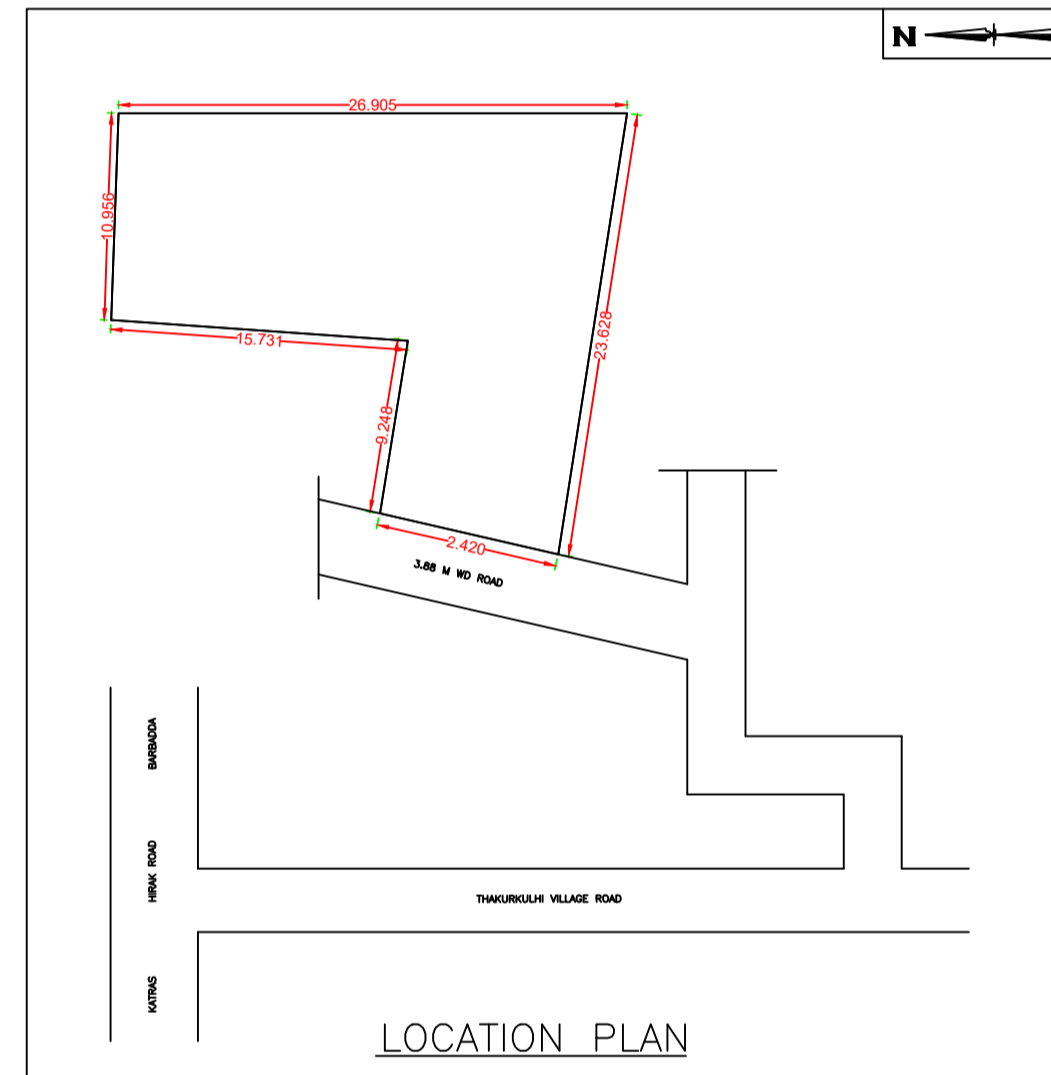
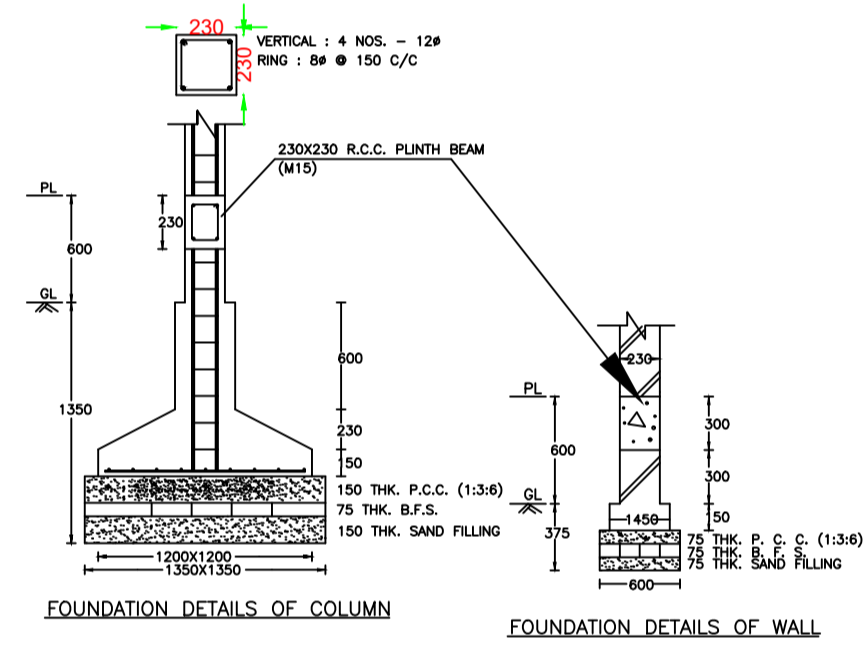
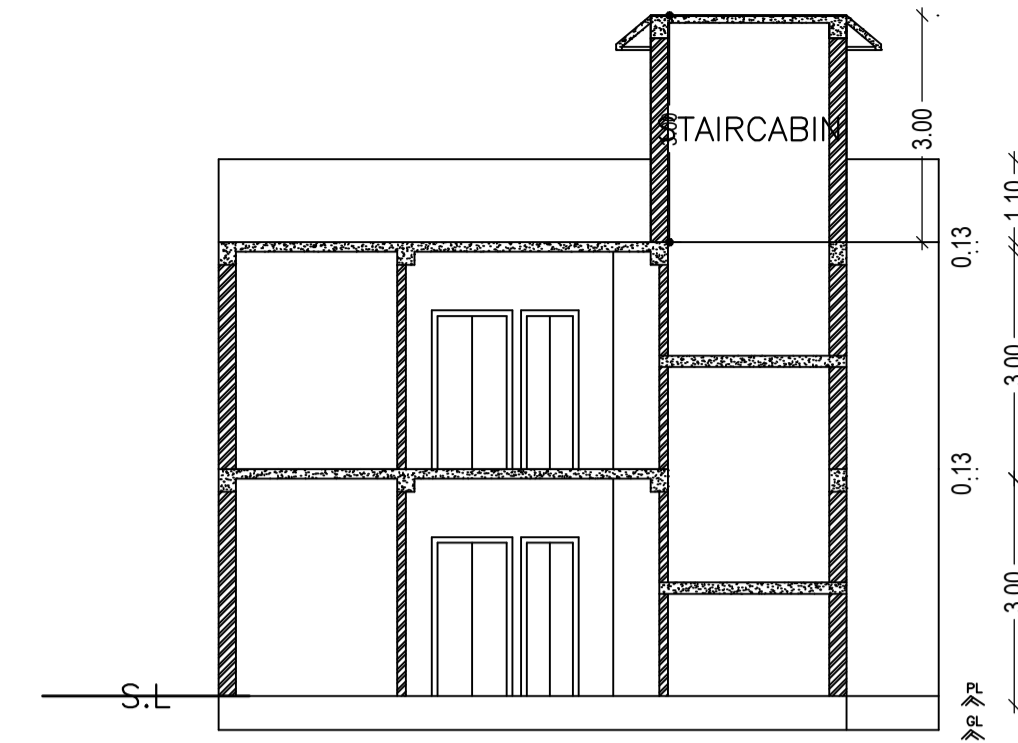

LOCATION PLAN

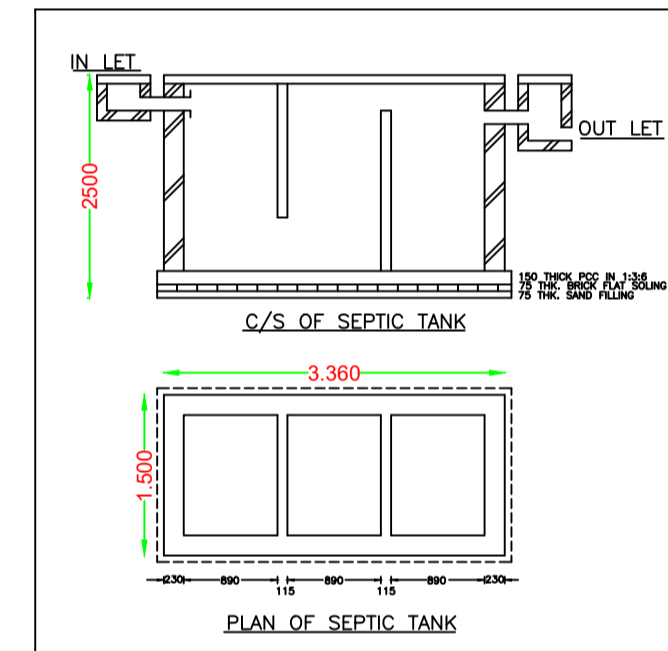

PLAN OF SEPTIC TANK

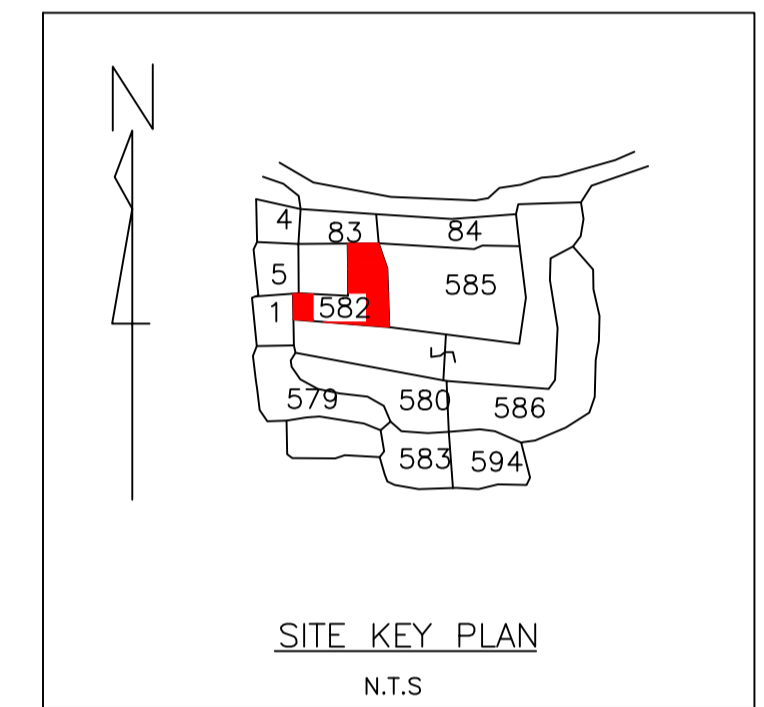

SITE KEY PLAN
N.T.S

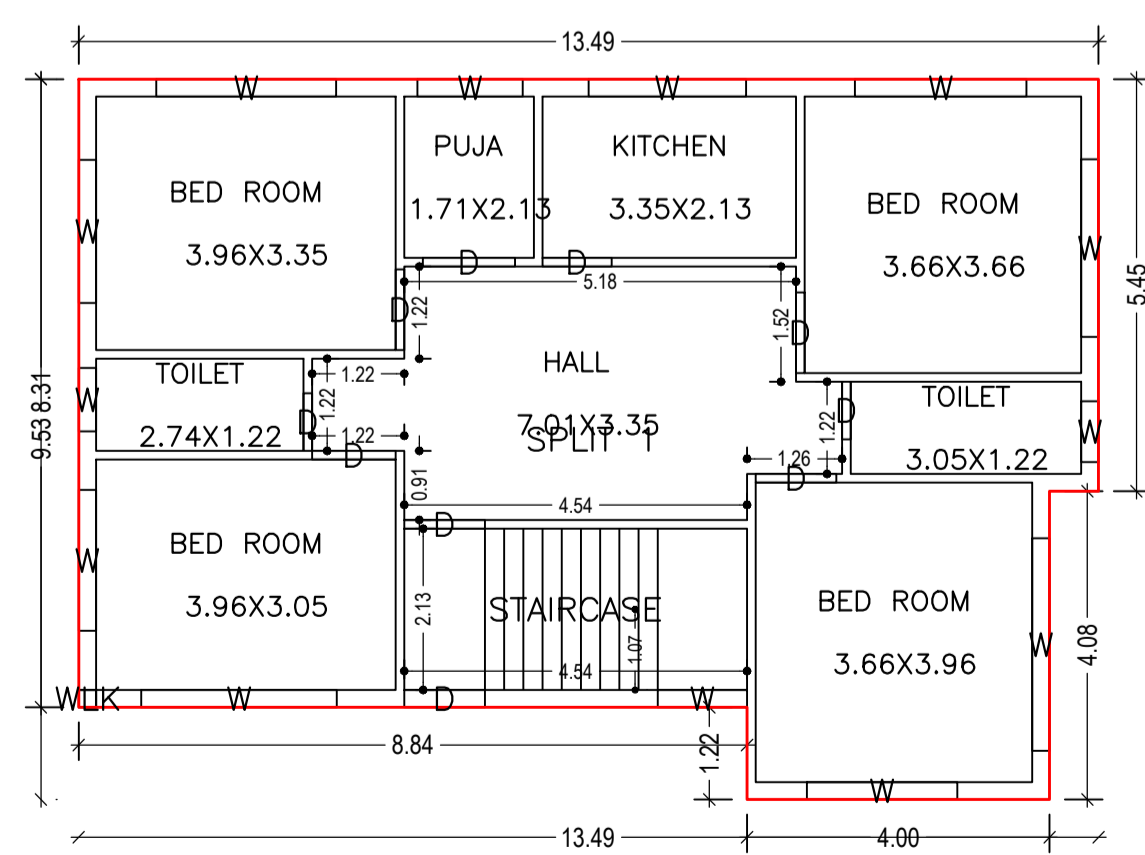

GROUND FLOOR PLAN
(Proposed)
(SCALE 1:100)

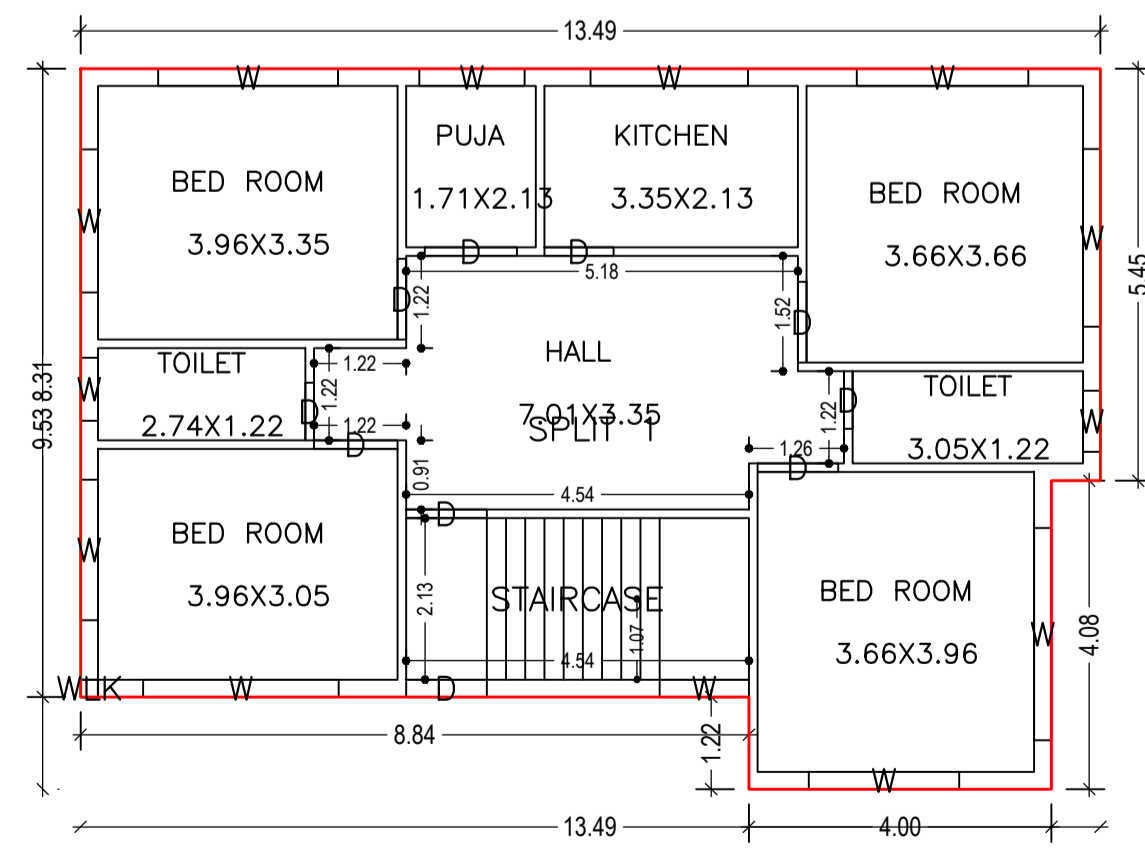

FIRST FLOOR PLAN
(Proposed)
(SCALE 1:100)

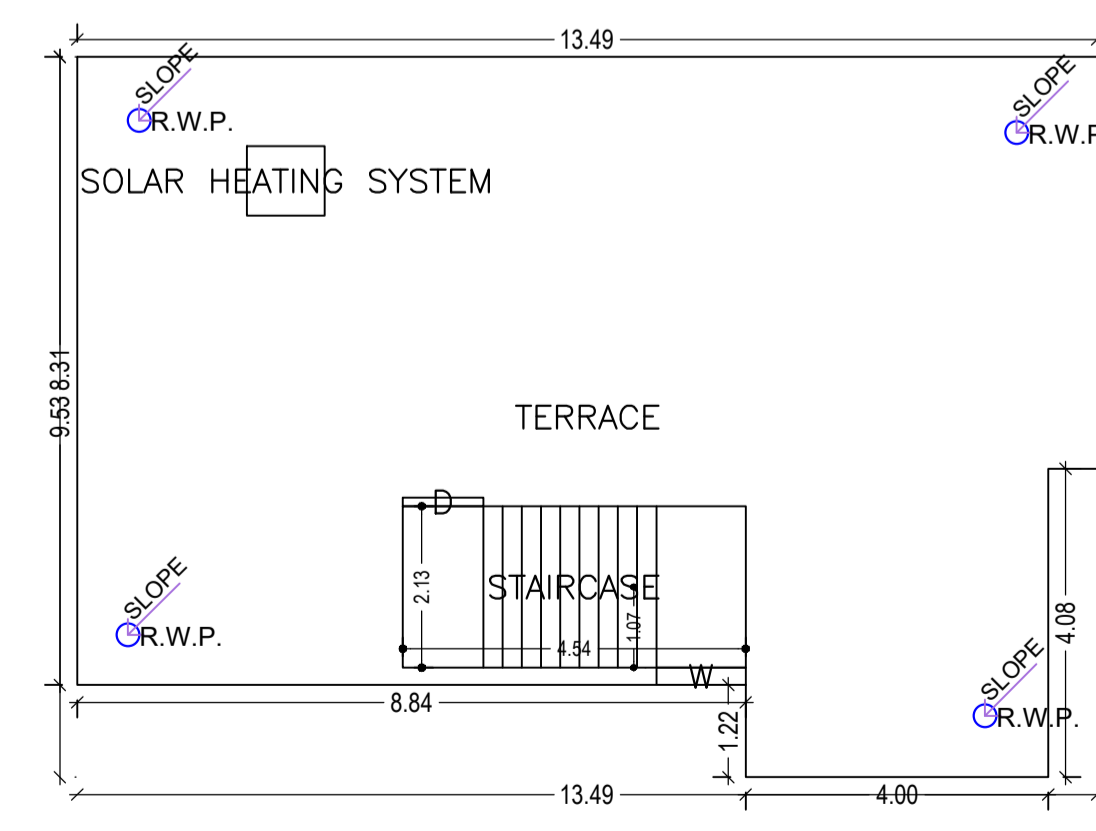

TERRACE FLOOR PLAN
(SCALE 1:100)

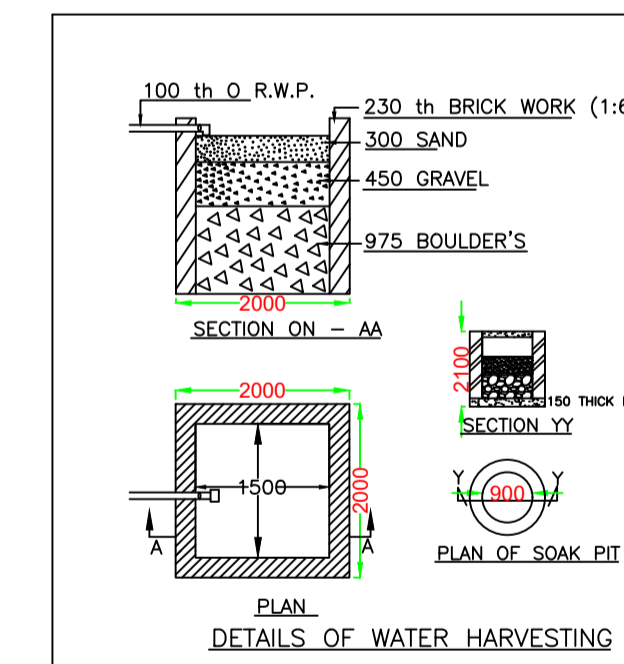

PLAN DETAILS OF WATER HARVESTING

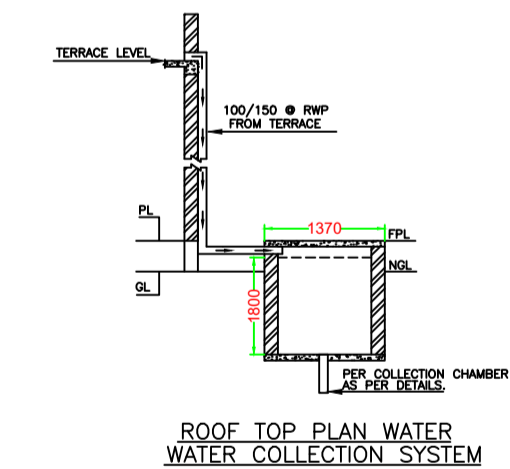

ROOF TOP PLAN WATER COLLECTION SYSTEM

LTP NAME AND SIGNATURE	STRUCTURAL ENG'S NAME AND SIGNATURE	BUILDER NAME AND SIGNATURE	DIGITAL SIGNATURE
JITENDAR KUMAR DMC/DFTMN/0006/2018			