

Proposal Basic Information	
Proposal File No.	DMC/BP/0168/W21/2021
Owner Name	SMT. SAROJNI DEVI
Khata No	NEW - 106, OLD - 31
Plot No	NEW - 612, OLD - 303
Village Name	Baramuri
Use	Residential
SubUse	Bungalow/ Dwelling / Non Apartment

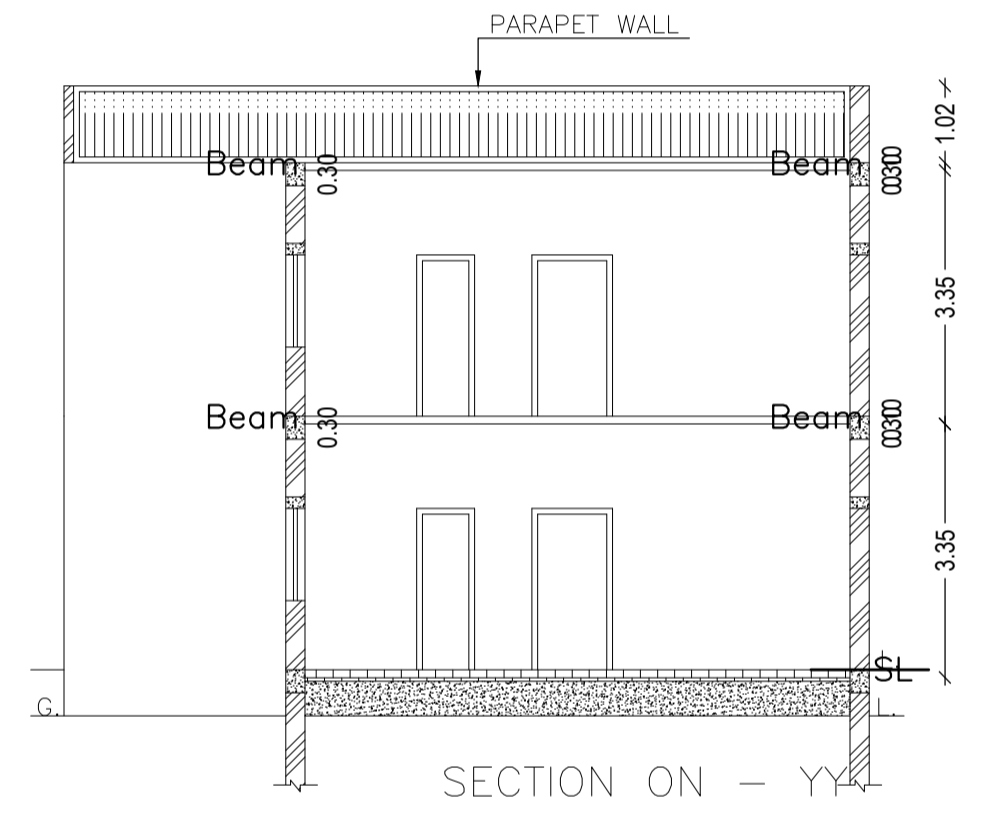
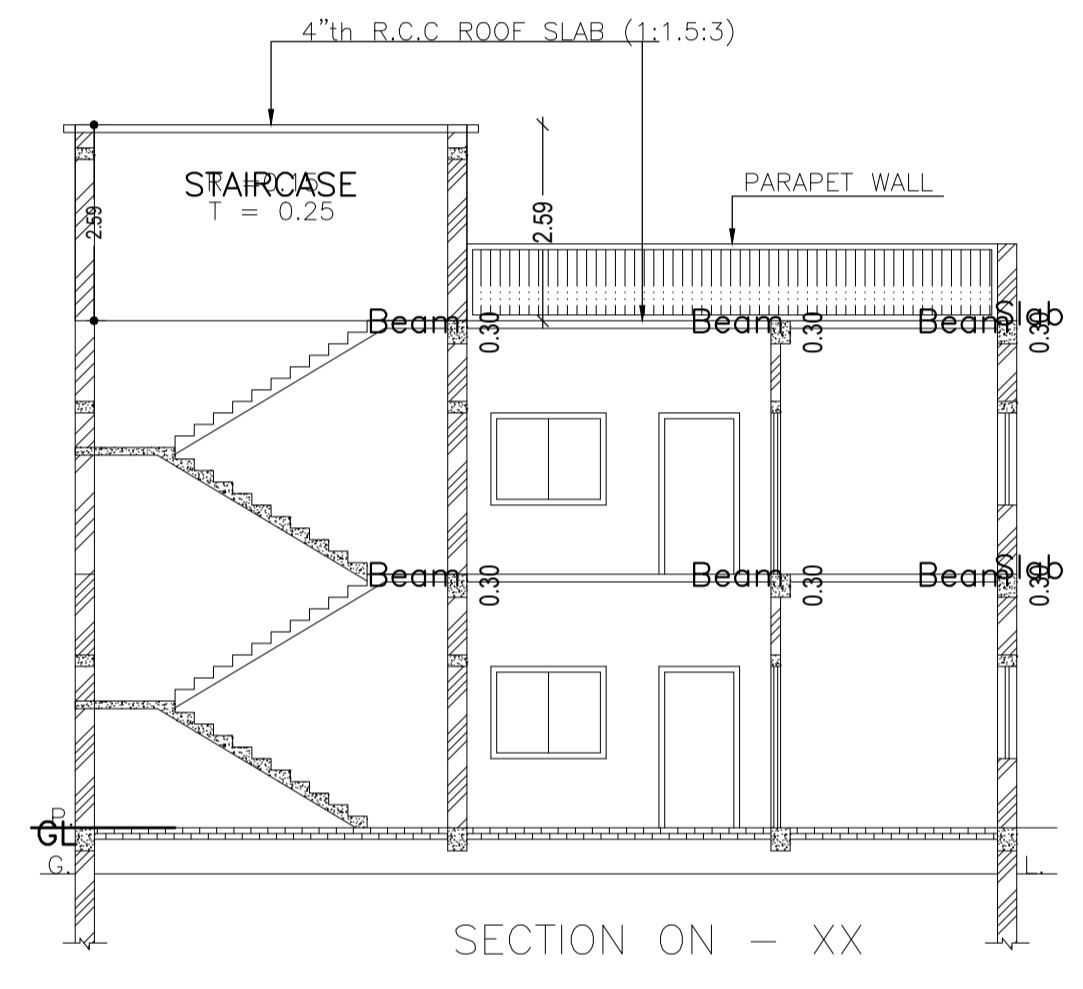
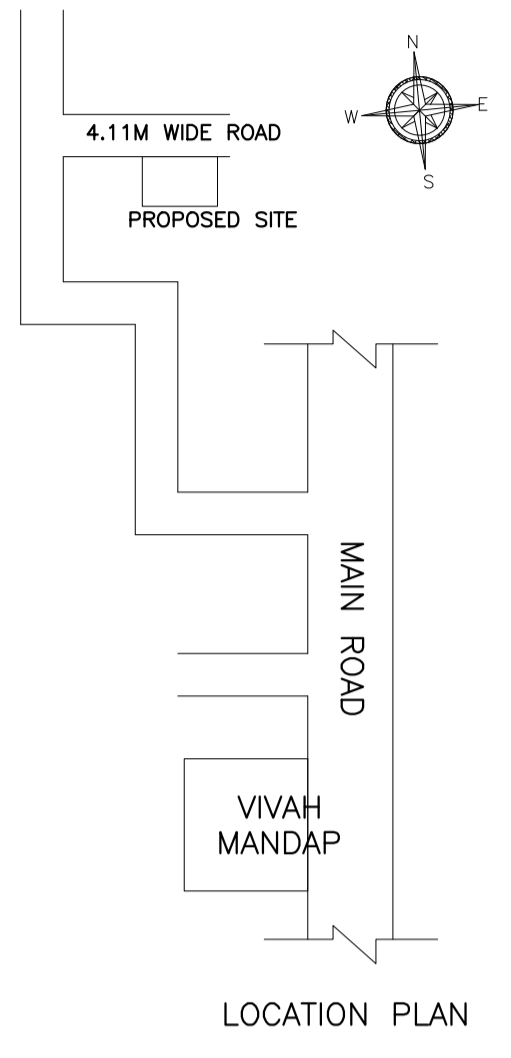
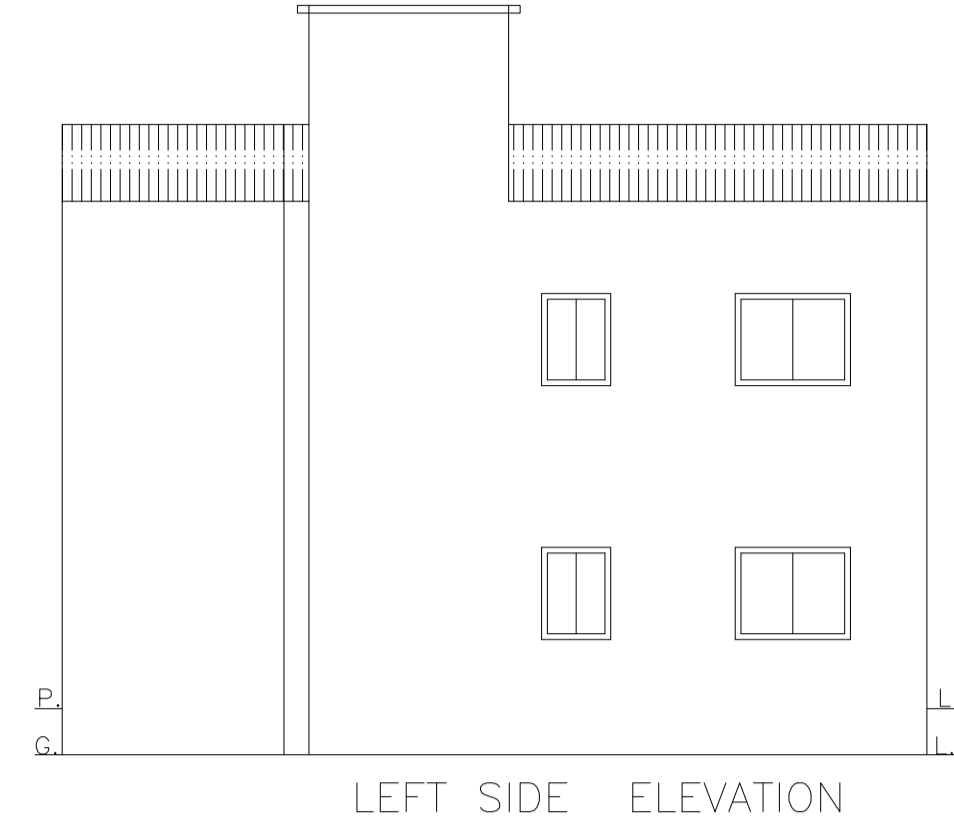
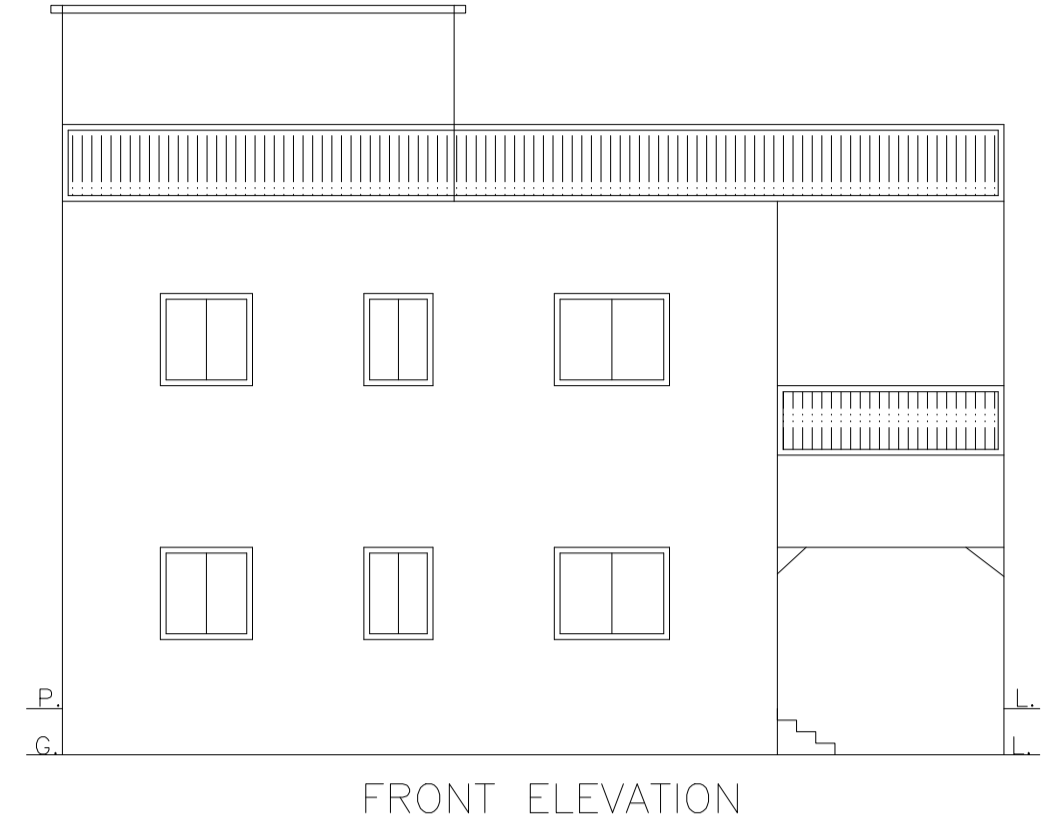
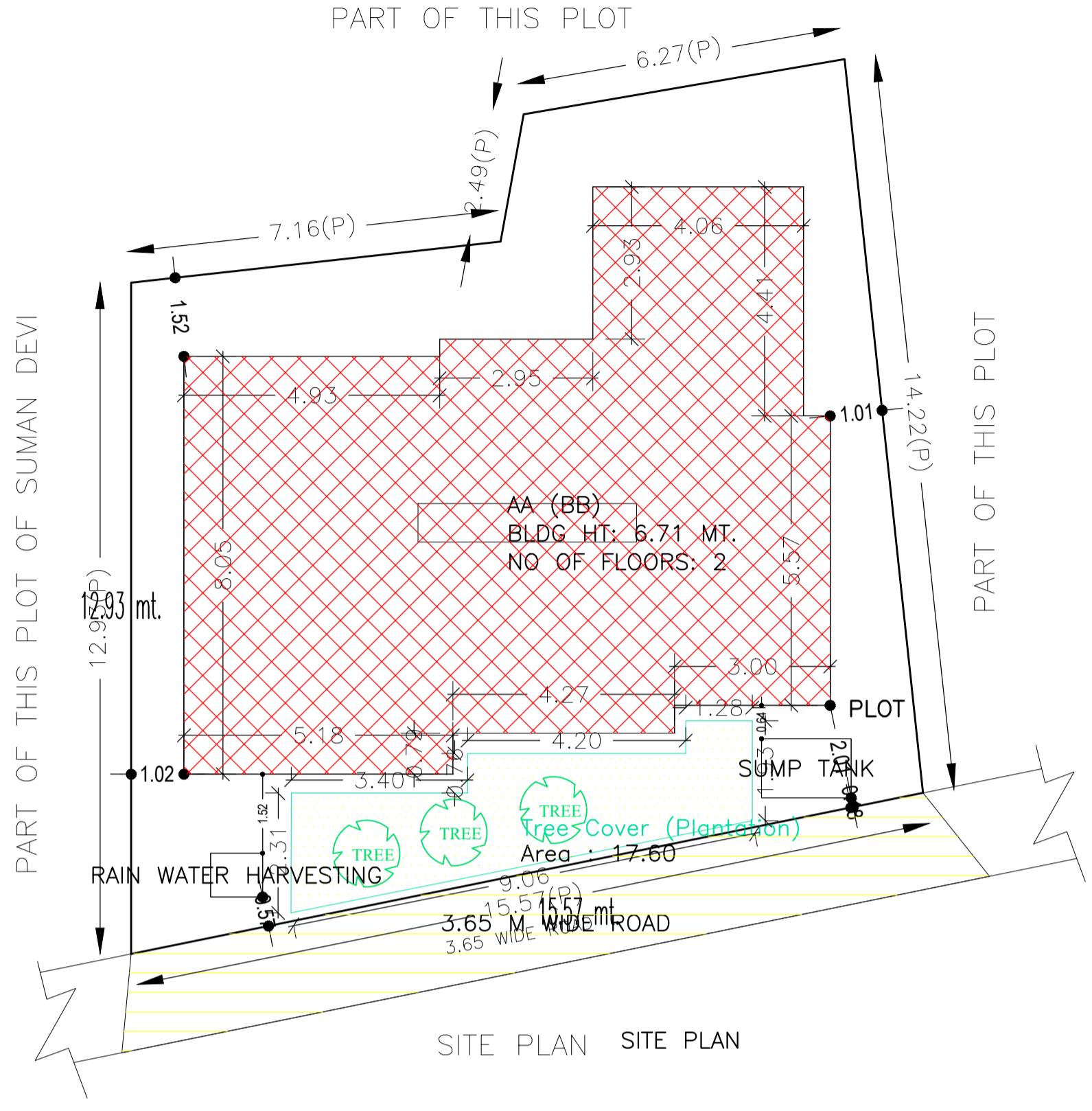

AREA STATEMENT		VERSION NO. : 1.0.60
DHANBAD MUNICIPAL CORPORATION		VERSION DATE: 16/10/2020
PROJECT DETAIL:		
Region: JHARKHAND URBAN LOCAL BODIES	Plot Use: Residential	
District: DHANBAD	Plot SubUse: Bungalow/ Dwelling / Non Apartment	
Authority: DHANBAD MUNICIPAL CORPORATION	PlotNearbyReligiousStructure: NA	
Inward No: DMC/BP/0168/W21/2021	Plot/SubPlot No: NEW - 612 - OLD - 303	
Application Type: General Proposal	North: Road Width - 3.65M WIDE ROAD	
Project Type: Building Permission	South: Plot No. - PART OF THIS PLOT	
Nature of Development: New	East: Plot No. - PART OF THIS PLOT OF SUMAN DEVI	
Location of Development Area: Old Area	West: Plot No. - PART OF THIS PLOT	
AREA DETAILS:		
AREA OF PLOT (Minimum)	(A)	SQ.MT. 196.55
NET AREA OF PLOT/Gross Plot Area - Deduction from Gross Plot area	(A-Deductions)	196.55
Deduction for Balance Plot Area(from Gross Plot Area)		
Common Plot		17.60
Total		17.60
BALANCE AREA OF PLOT(Net Plot Area - Recreational/Amenity space)	(A-Deductions)	178.94
PLOT AREA FOR COVERAGE(Net Plot Area)	(A-Deductions)	196.55
Plot Area for FAR (Net Plot Area + Road/Widening Area)	(A-Deductions)	196.55
COVERAGE CHECK		
Permissible Coverage area (70.00 %)		137.59
Proposed Coverage Area (54.21 %)		106.55
Total Prop. Coverage Area (54.21 %)		106.55
Balance coverage area (15.79 %)		31.04
FAR CHECK		
Perm. FAR Area (1.50)		294.83
Total Perm. FAR area		294.83
Residential FAR		213.09
Proposed FAR Area		213.09
Total Proposed FAR Area		213.09
Consumed FAR (Factor)		1.08
Balance FAR Area		81.74
BUILT UP AREA CHECK		
Total Proposed BuiltUp Area		213.10
ARCHITECT (Regd)	AMARENDRA KUMAR	
ENGINEER (Regd)		
SUPERVISOR (Regd)		
OWNER (Regd)	SMT. SAROJNI DEVI	
DEVELOPMENT AUTHORITY		LOCAL BODY

COLOR INDEX	
PLOT BOUNDARY	Black
ABUTTING ROAD	Green
PROPOSED CONSTRUCTION	Red
COMMON PLOT	Yellow
ROAD WIDENING AREA	Blue
EXISTING (To be retained)	Light Blue
EXISTING (To be demolished)	Light Yellow

Buildingwise Floor FAR Details				
Floor Name	Building Name AA (BB)		Total	
	Proposed Built Up Area (Sq.mt.)	Proposed FAR Area (Sq.mt.)	Total Proposed Built Up Area (Sq.mt.)	Total FAR Area (Sq.mt.)
Ground Floor	106.55	106.55	106.55	106.55
First Floor	106.55	106.55	106.55	106.55
Terrace Floor	0.00	0.00	0.00	0.00
Total:	213.10	213.10	213.10	213.10

Building USE/SUBUSE Details			
Building Name	Building Use	Building SubUse	Building Structure
AA (BB)	Residential	Bungalow/ Dwelling / Non Apartment	Non-Highrise

FAR & Tenement Details (Table 4c-1)						
Building	No. of Same Bldg	Total Built Up Area (Sq.mt.)	Proposed FAR Area (Sq.mt.)	Total FAR Area (Sq.mt.)	Total Consumed Additional FAR Area (Sq.mt.)	Tnmt (No.)
AA (BB)	1	213.10	213.10	213.10	213.10	01
Grand Total:	1	213.10	213.10	213.10	213.10	01

UnitBUA Table for Building :AA (BB)						
FLOOR	Name	UnitBUA Type	UnitBUA Area	Carpet Area	No. of Rooms	No. of Tenement
GROUND FLOOR PLAN	SPLIT AA	FLAT	213.09	212.76	9	1
FIRST FLOOR PLAN	SPLIT AA	FLAT	0.00	0.00	9	0
Total:	-	-	213.09	212.76	18	1

SCHEDULE OF DOOR:				
BUILDING NAME	NAME	LENGTH	HEIGHT	NOS
AA (BB)	D	0.76	2.10	06
AA (BB)	D	0.91	2.10	02
AA (BB)	D	1.07	2.10	10

SCHEDULE OF WINDOW/VENTILATION:				
BUILDING NAME	NAME	LENGTH	HEIGHT	NOS
AA (BB)	W	0.61	1.20	04
AA (BB)	W	0.91	1.20	04
AA (BB)	W	1.22	1.20	02
AA (BB)	W	1.52	1.20	08
AA (BB)	W	2.70	1.20	02

Building :AA (BB)					
Floor Name	Total Built Up Area (Sq.mt.)	Proposed FAR Area (Sq.mt.)	Total FAR Area (Sq.mt.)	Total Consumed Additional FAR Area (Sq.mt.)	Tnmt (No.)
Ground Floor	106.55	106.55	106.55	106.55	01
First Floor	106.55	106.55	106.55	106.55	00
Terrace Floor	0.00	0.00	0.00	0.00	00
Total :	213.10	213.10	213.10	213.10	01
Total Number of Same Buildings :	1				
Total :	213.10	213.10	213.10	213.10	01

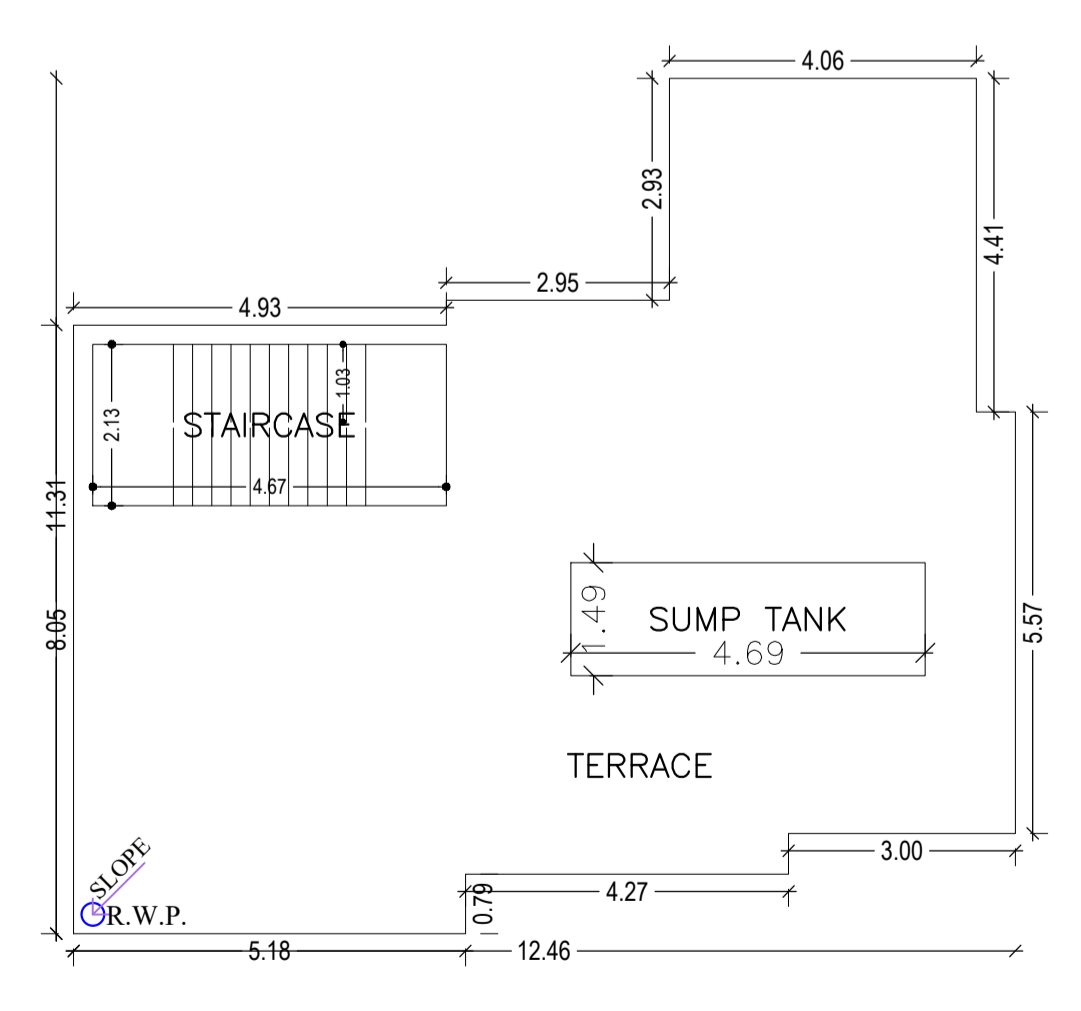
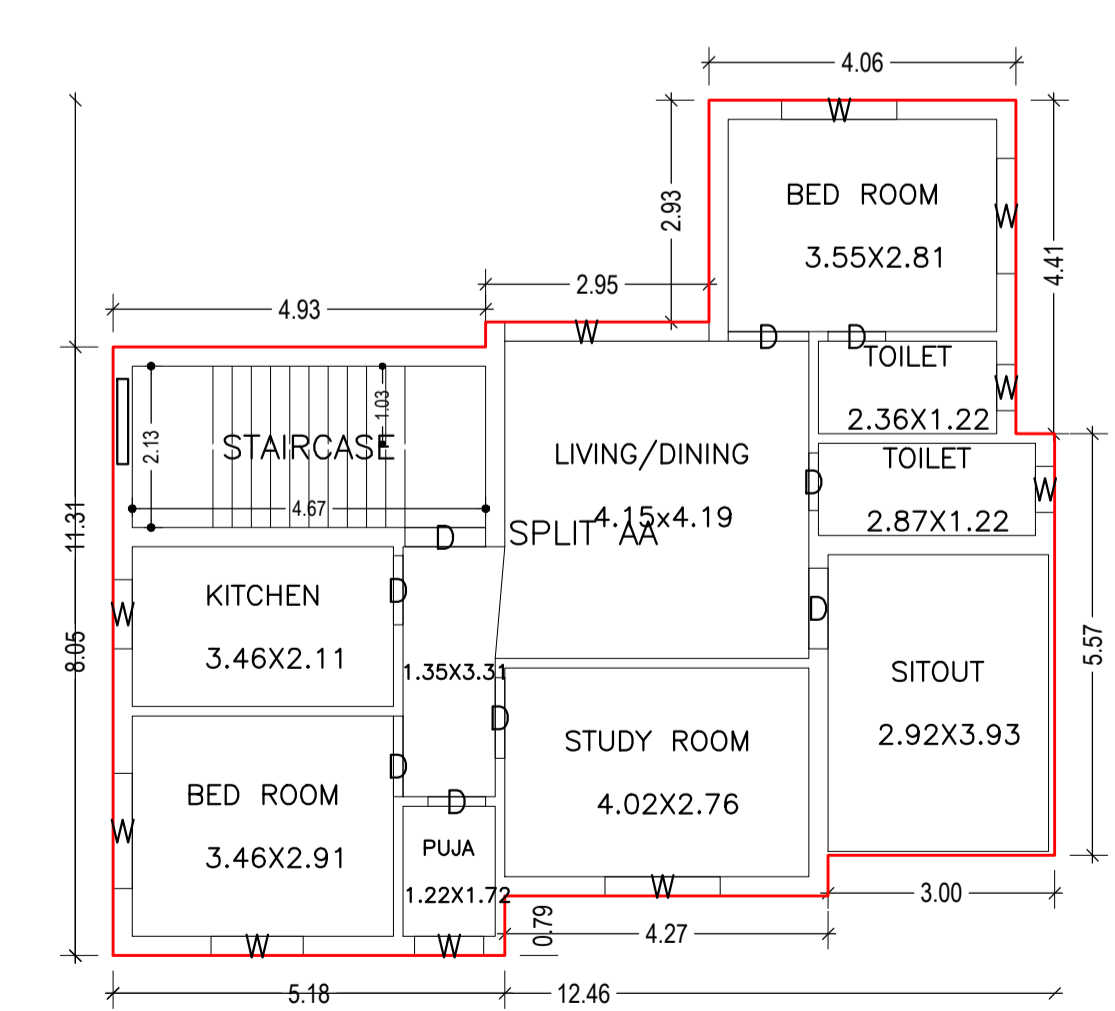
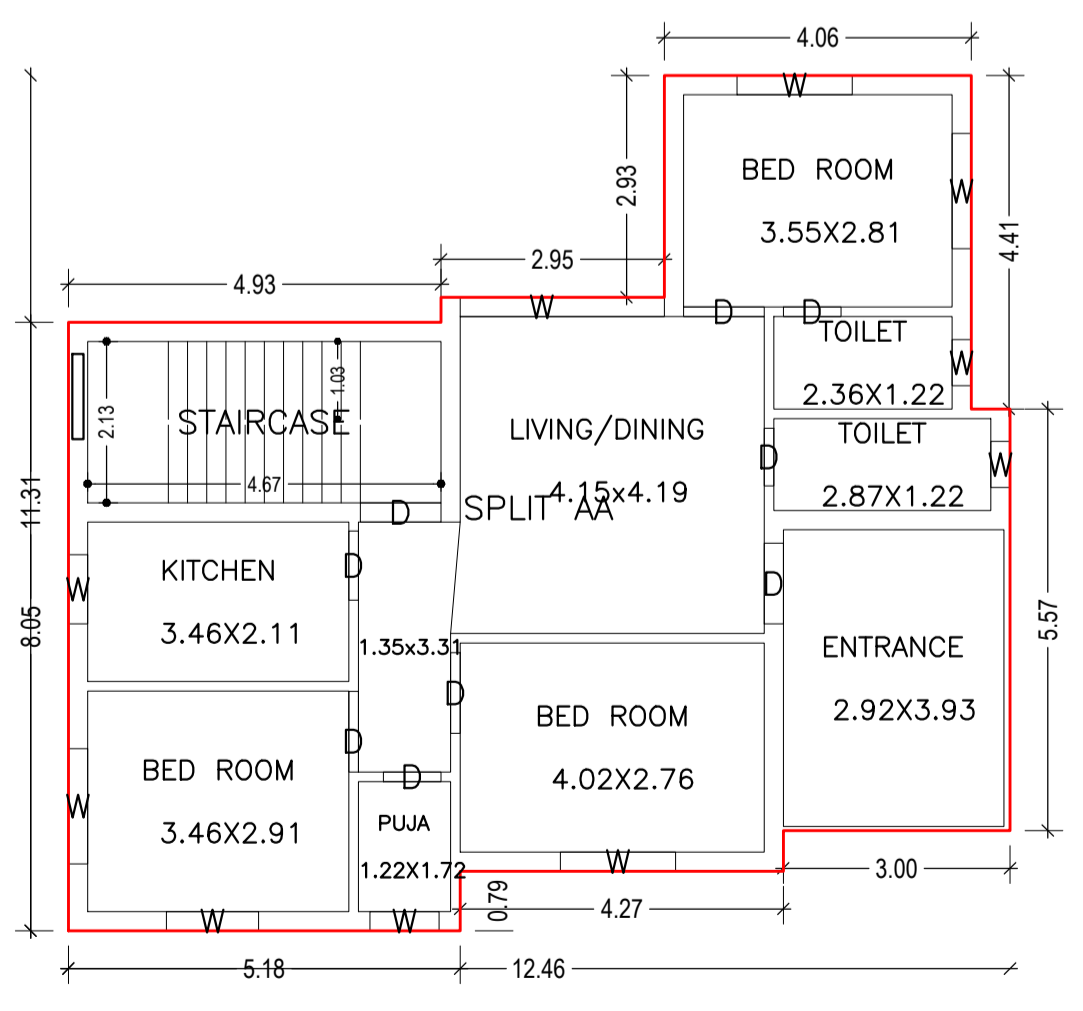

LTP NAME AND SIGNATURE	STRUCTURAL ENG'S NAME AND SIGNATURE	BUILDER NAME AND SIGNATURE	DIGITAL SIGNATURE
AMARENDRA KUMAR DMC/ENG/0009/2016			

Proposal Basic Information

Proposal File No.	DMC/BP/0168/W21/2021
Owner Name	SMT. SAROJNI DEVI
Khata No	NEW - 106, OLD - 31
Plot No	NEW - 612, OLD - 303
Village Name	Baramuri
Use	Residential
SubUse	Bungalow/ Dwelling / Non Apartment

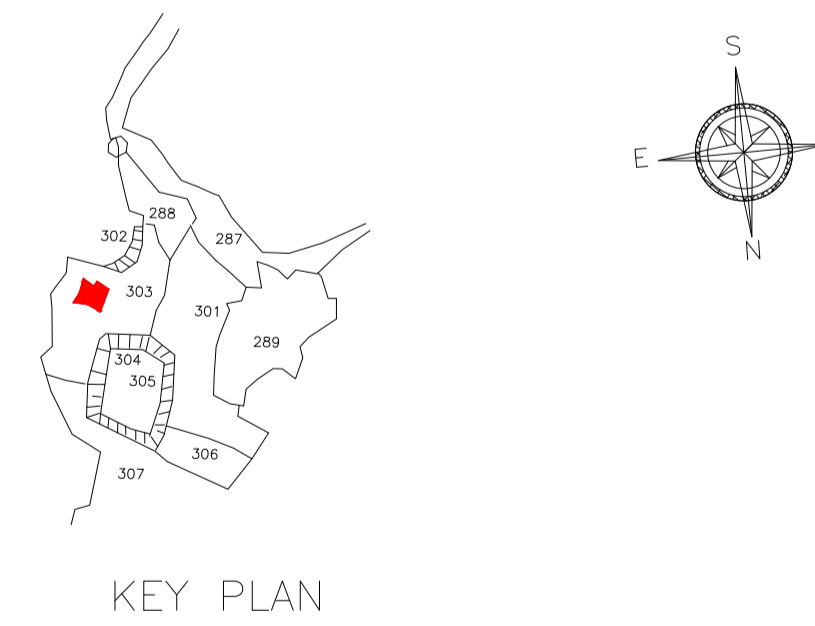
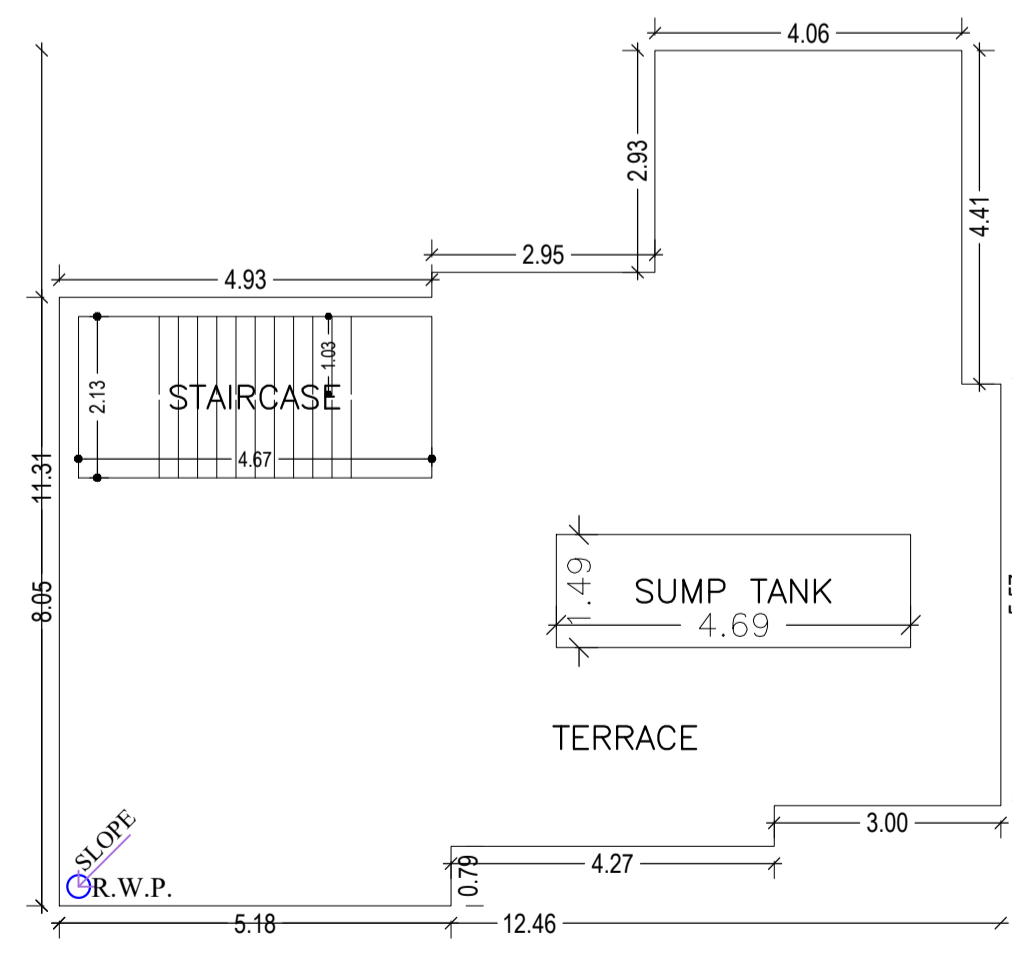
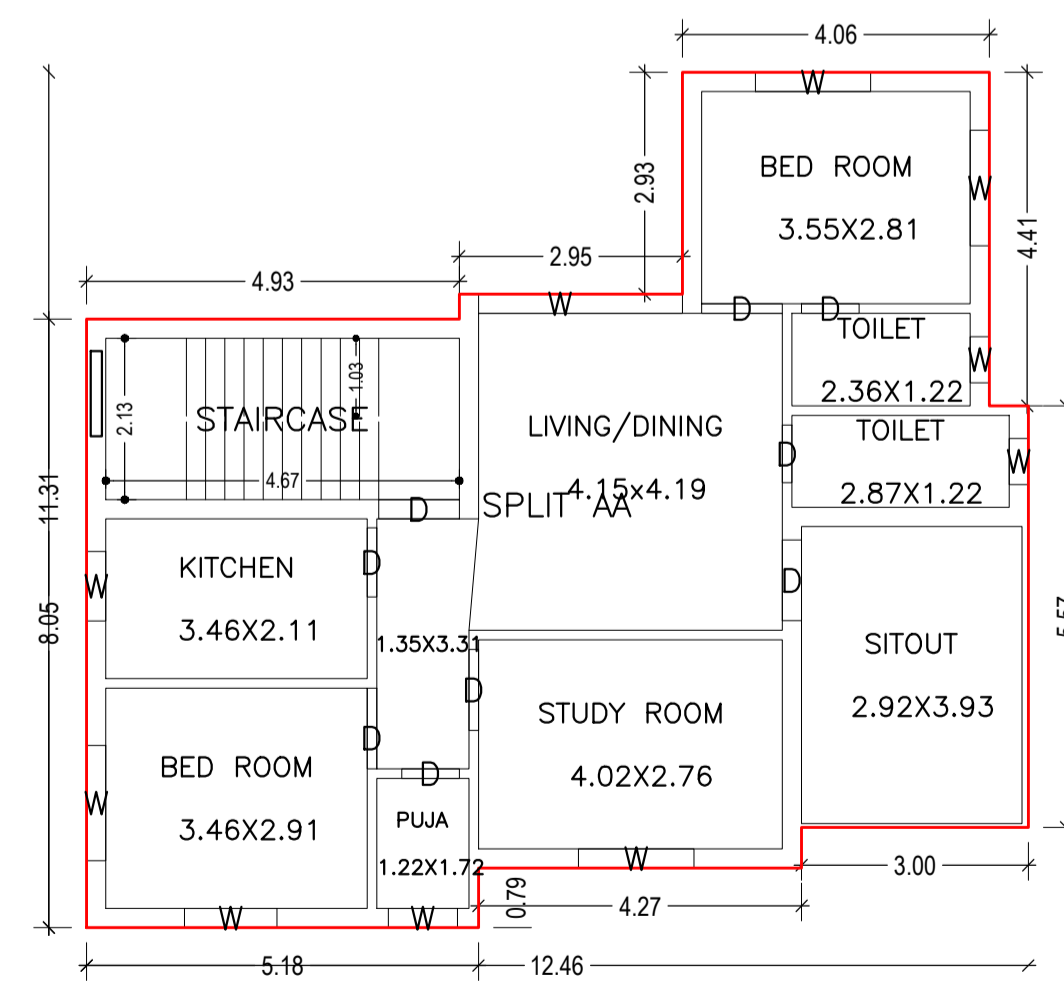
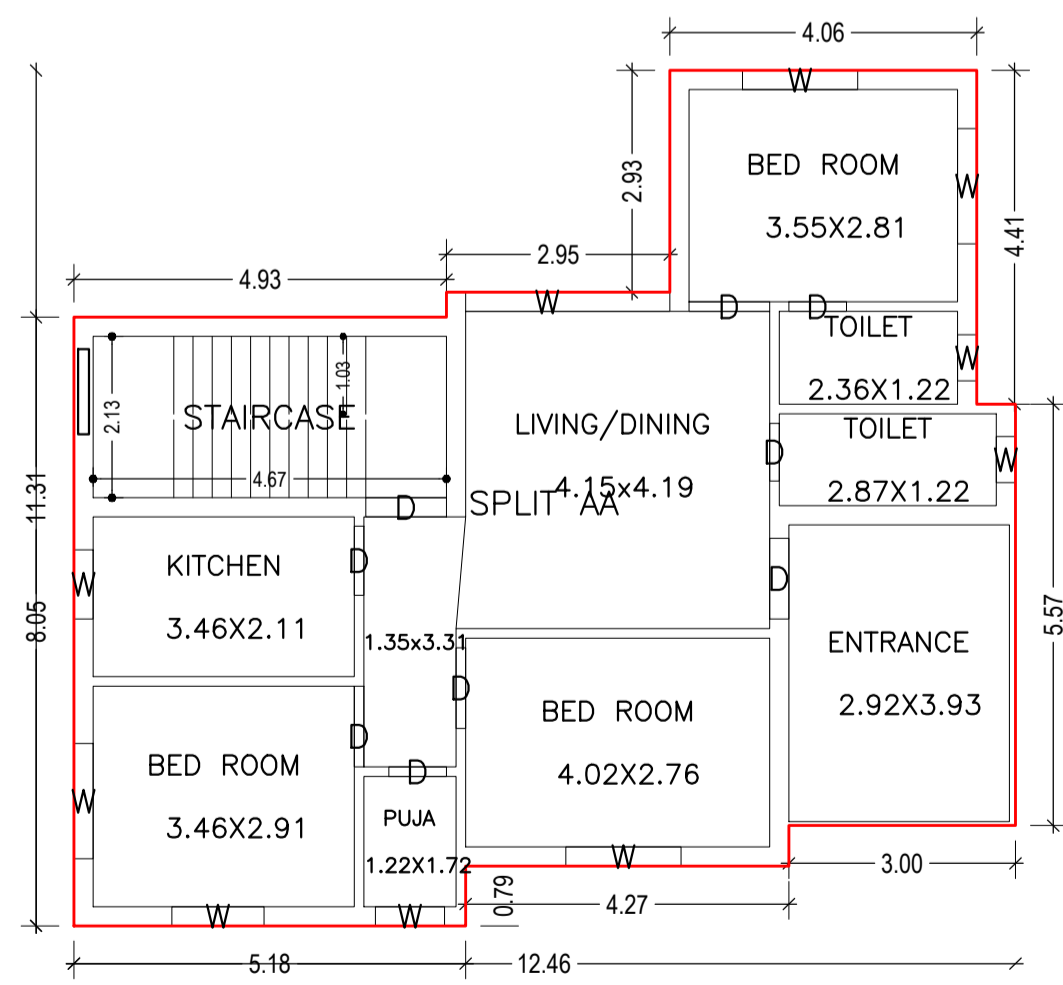
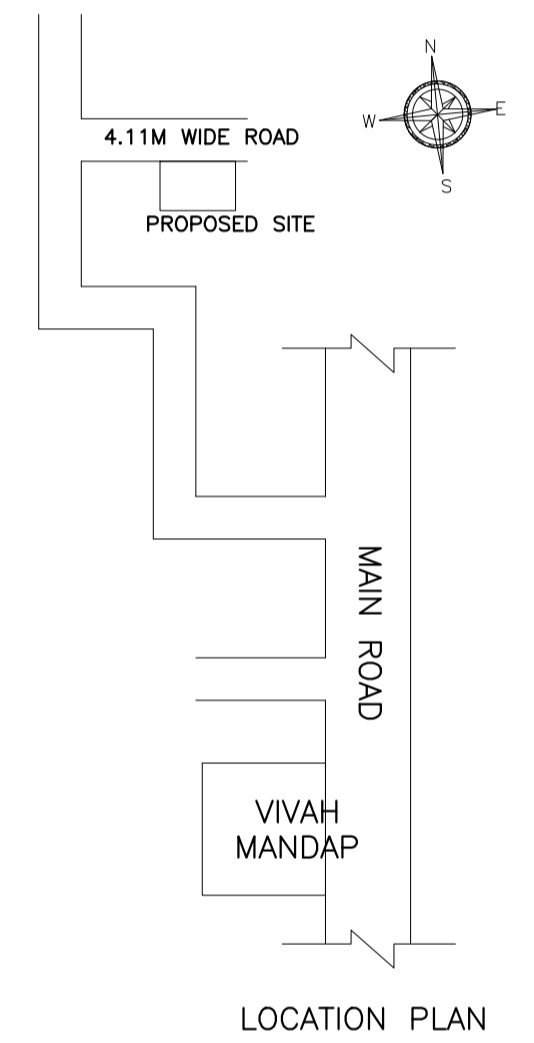
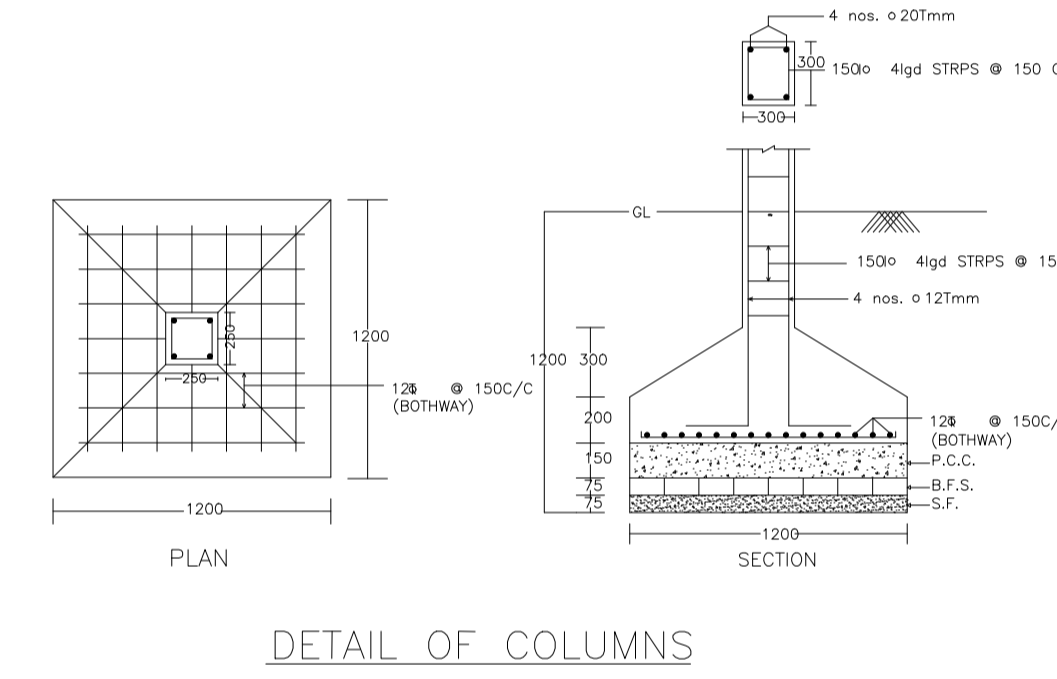
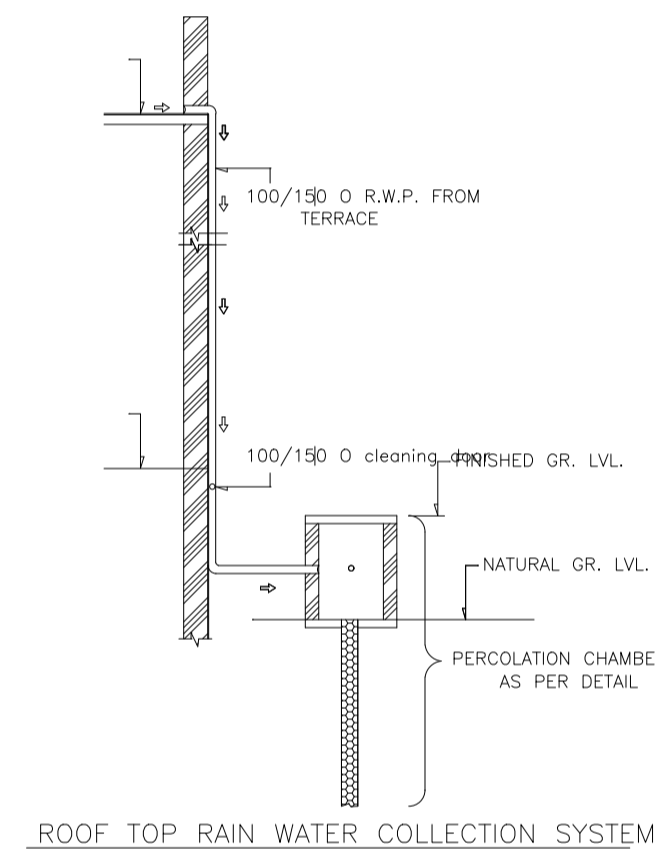
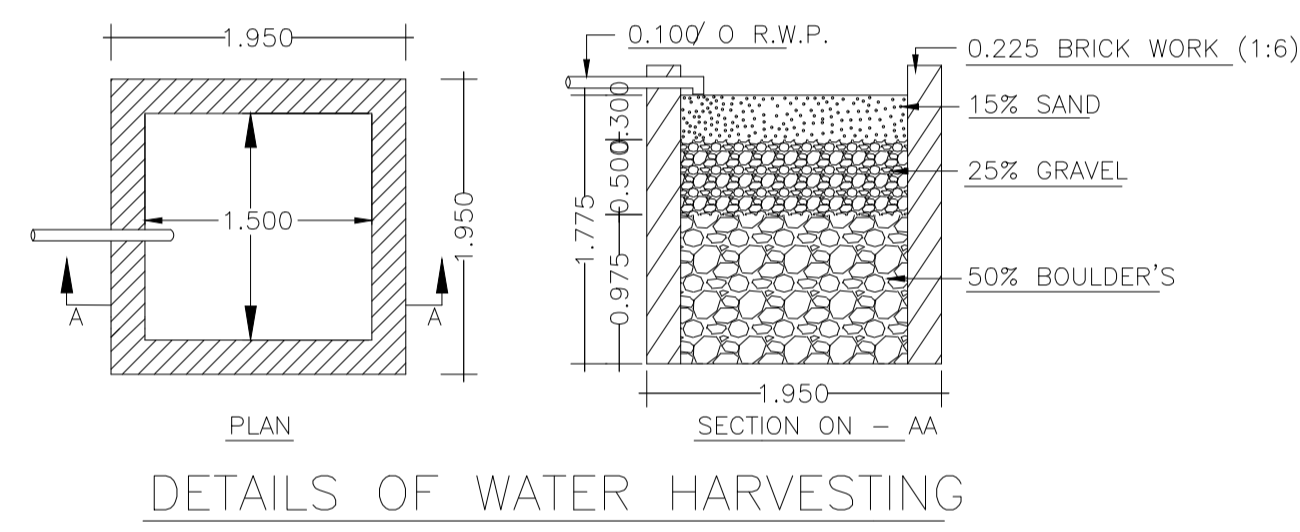
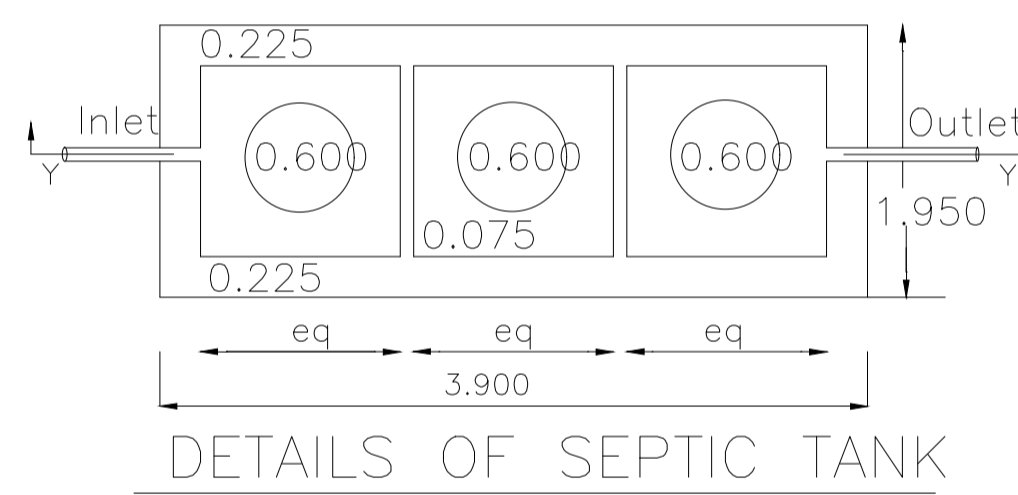
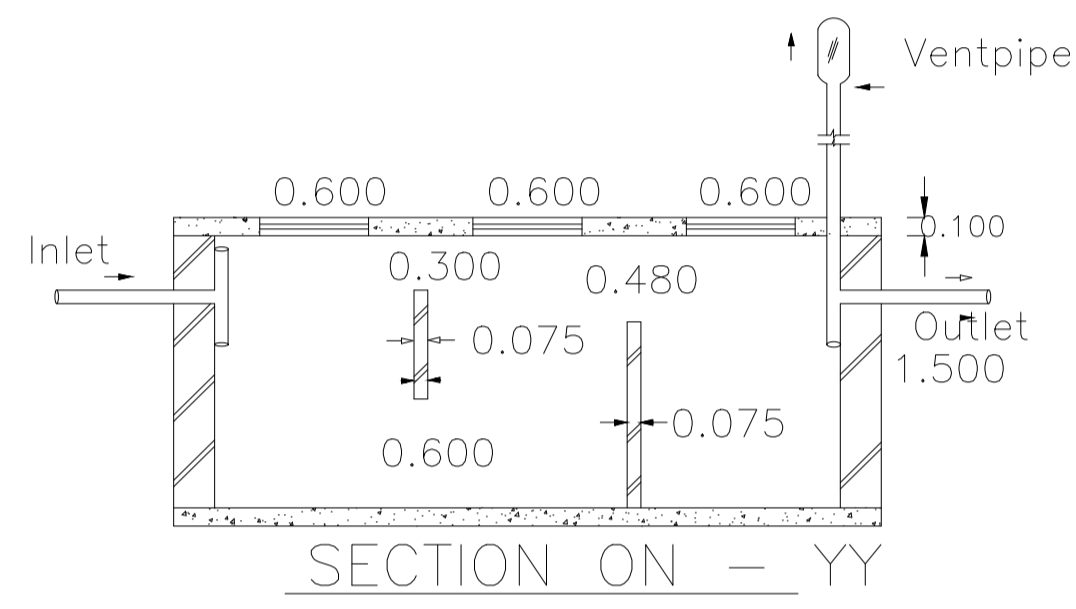
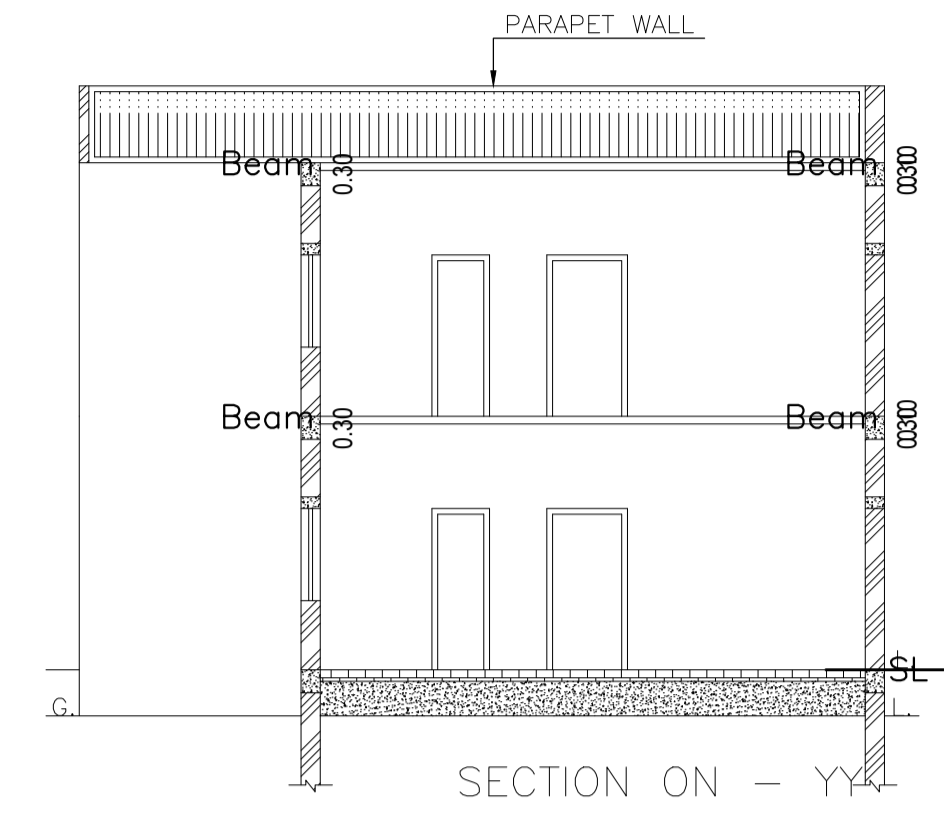
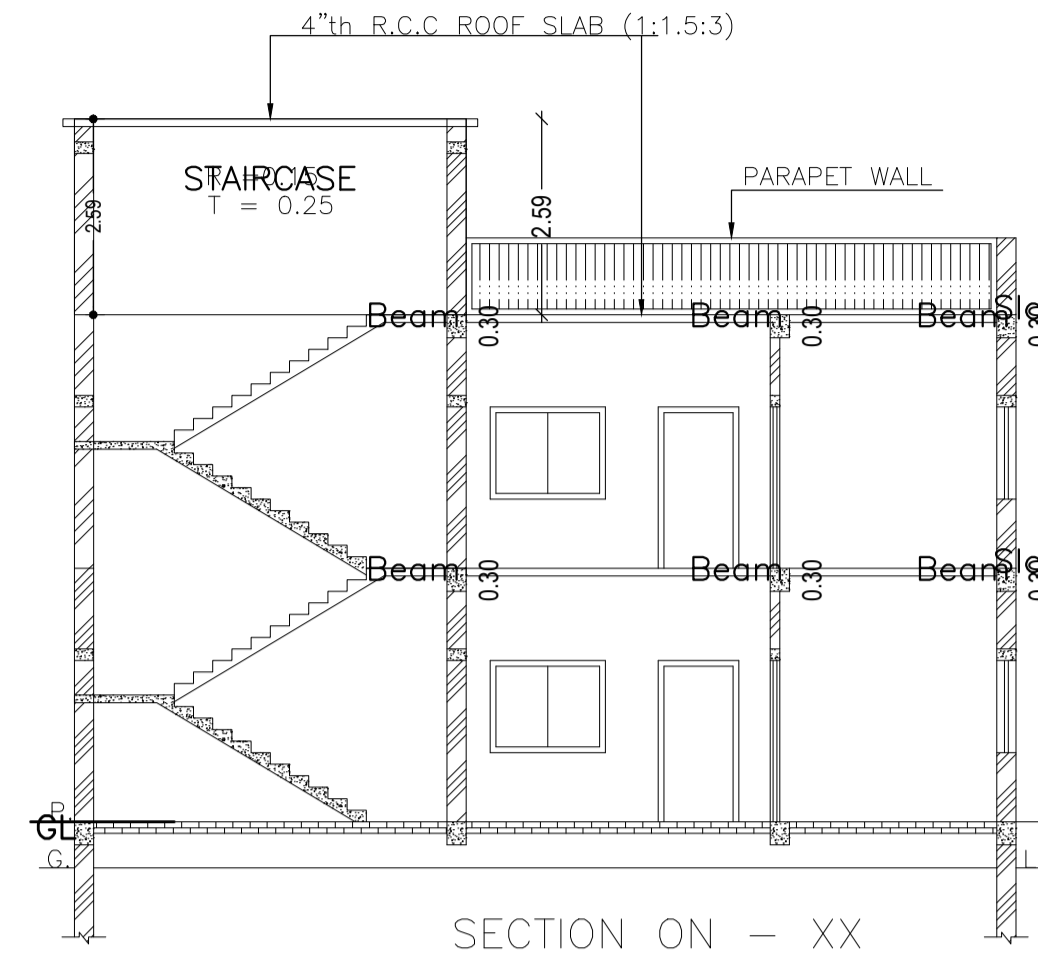
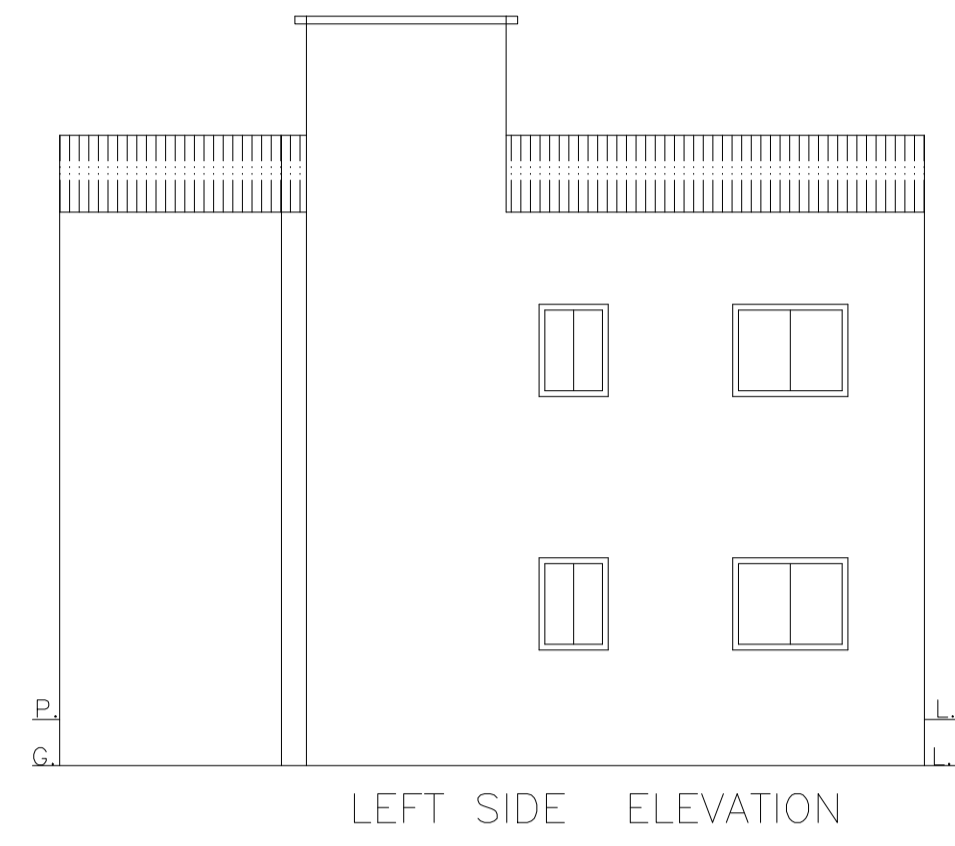
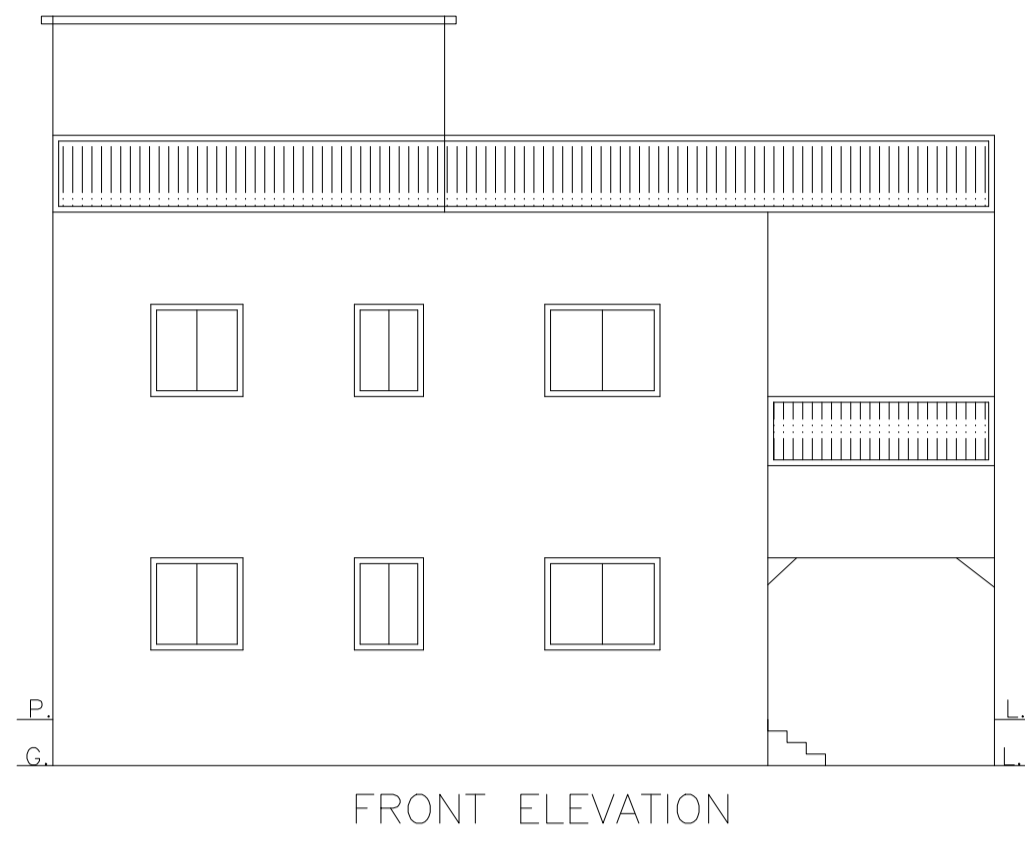

LTP NAME AND SIGNATURE	STRUCTURAL ENG'S NAME AND SIGNATURE	BUILDER NAME AND SIGNATURE	DIGITAL SIGNATURE
AMARENDRA KUMAR DMC/ENG/0009/2016			