

Proposal Basic Information	
Proposal File No.	DMC/BP/0054/W21/2021
Owner Name	SMT SUNITA DEVI
Khata No	110
Plot No	1985
Village Name	Dhaiya
Use	Residential
SubUse	Semidetached

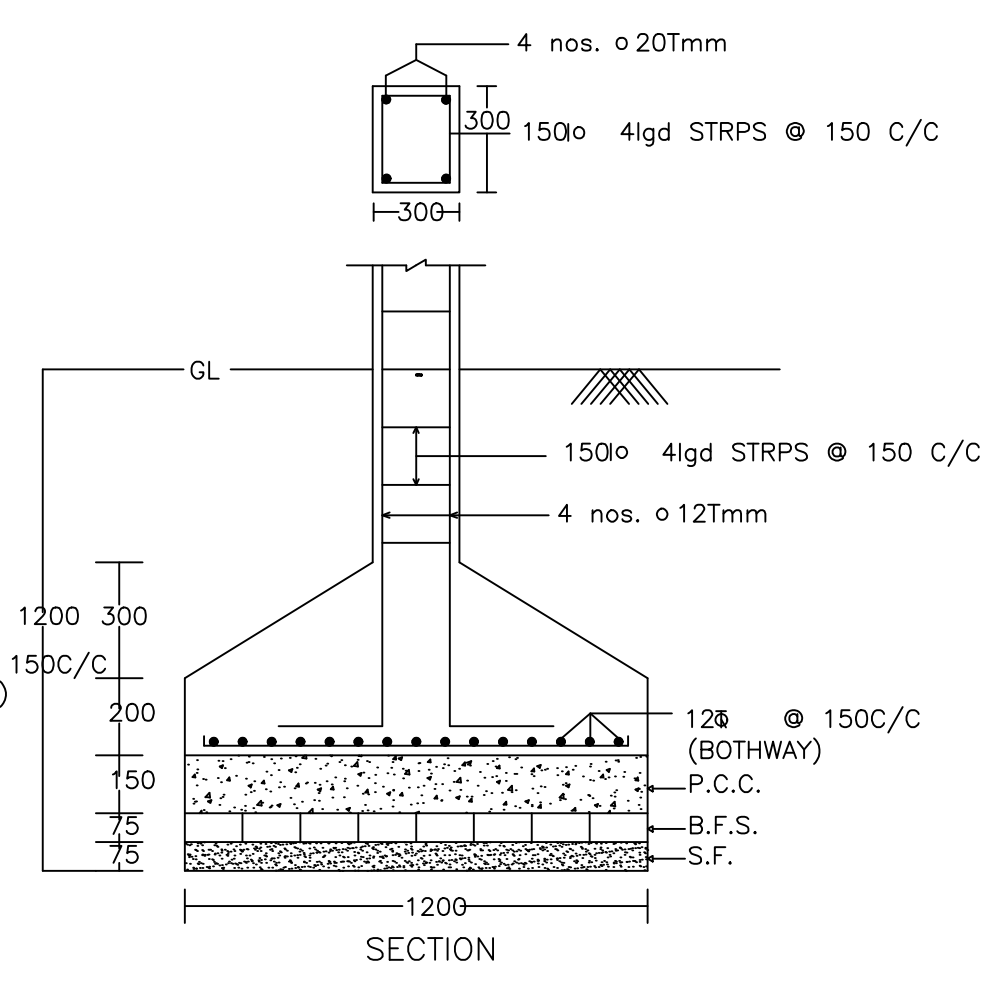

DETAIL OF COLUMNS

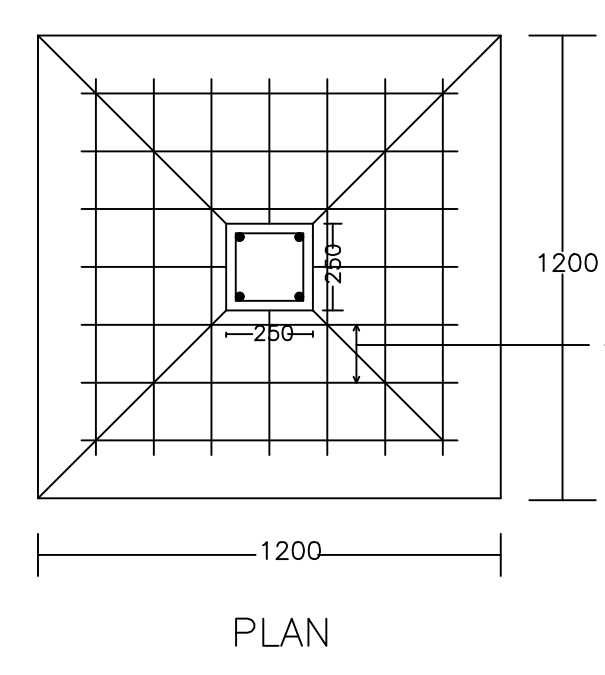
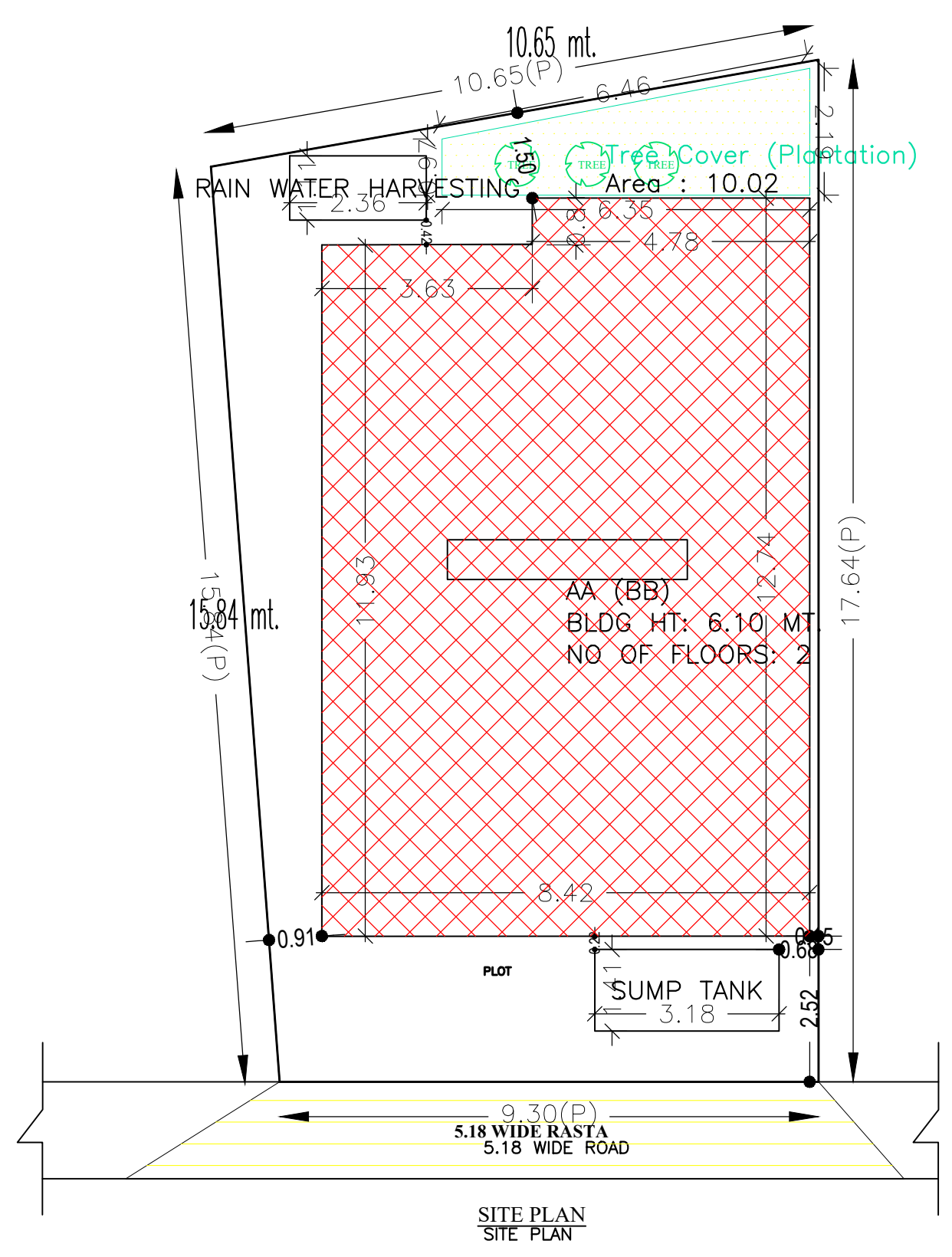
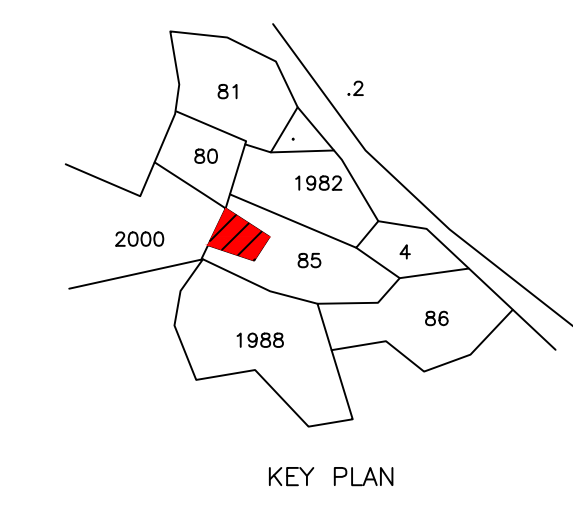
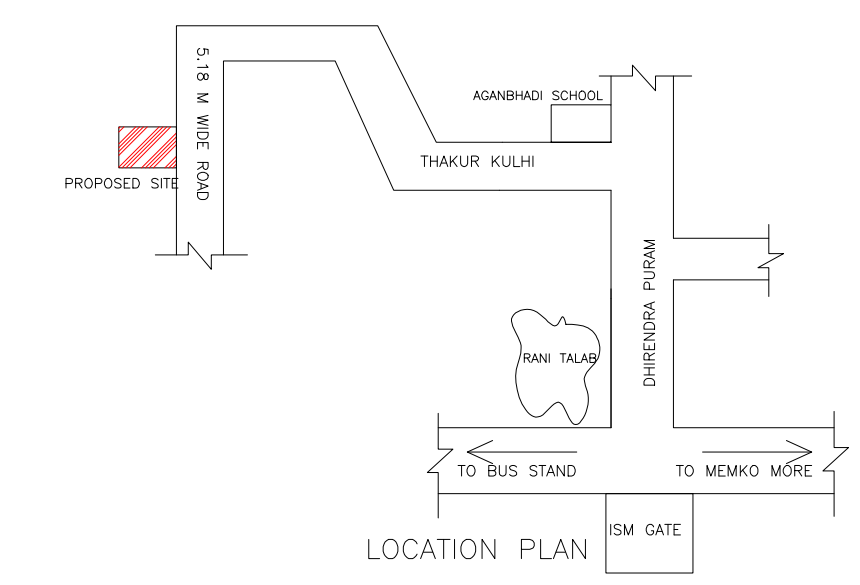

AREA STATEMENT		VERSION NO. : 1.0.55
DHANBAD MUNICIPAL CORPORATION		VERSION DATE: 16/10/2020
<b>PROJECT DETAIL:</b>		
Region: JHARKHAND URBAN LOCAL BODIES	Plot Use: Residential	
District: DHANBAD CORPORATION	Plot SubUse: Semidetached	
Authority: DHANBAD MUNICIPAL CORPORATION	PlotNearby/ReligiousStructure: NA	
Inward No: DMC/BP/0054/W21/2021	Plot/SubPlot No: 1985	
Application Type: General Proposal	North: Plot No. - PART OF THIS PLOT	
Project Type: Building Permission	South: Plot No. - PART OF THIS PLOT	
Nature of Development: New	East: Road Width - 5.18 M WIDE ROAD	
Location of Development Area: Old Area	West: Plot No. - PLOT NO - 2000	
<b>AREA DETAILS:</b>		
AREA OF PLOT (Minimum)	(A)	SQ.MT. 165.90
NET AREA OF PLOT (Gross Plot Area - Deduction from Gross Plot area)	(A-Deductions)	165.90
Deduction for Balance Plot Area (from Gross Plot Area)		
Common Plot		10.02
Total		10.02
BALANCE AREA OF PLOT (Net Plot Area - Recreational/Amenity space)	(A-Deductions)	155.87
PLOT AREA FOR COVERAGE (Net Plot Area)	(A-Deductions)	165.90
Plot Area for FAR (Net Plot Area + Road Widening Area)	(A-Deductions)	165.90
<b>COVERAGE CHECK</b>		
Permissible Coverage area ( 70.00 % )		116.13
Proposed Coverage Area ( 62.85 % )		104.27
Total Prop. Coverage Area ( 62.85 % )		104.27
Balance coverage area ( 7.15 % )		11.86
<b>FAR CHECK</b>		
Perm. FAR Area ( 1.80 )		298.62
Total Perm. FAR area		298.62
Residential FAR		208.57
Proposed FAR Area		208.57
Total Proposed FAR Area		208.57
Consumed FAR (Factor)		1.26
Balance FAR Area		90.05
<b>BUILT UP AREA CHECK</b>		
Total Proposed BuiltUp Area		208.57
ARCHITECT (Regd)	ABHISHEK KUMAR	
ENGINEER (Regd)		
SUPERVISOR (Regd)		
OWNER (Regd)	SMT SUNITA DEVI	
DEVELOPMENT AUTHORITY		LOCAL BODY

COLOR INDEX	
PLOT BOUNDARY	Black
ABUTTING ROAD	Green
PROPOSED CONSTRUCTION	Red
COMMON PLOT	Yellow
ROAD WIDENING AREA	Blue
EXISTING (To be retained)	Light Blue
EXISTING (To be demolished)	Dark Blue

Floor Name	Building Name		Total	
	Proposed Built Up Area (Sq.mt.)	Proposed FAR Area (Sq.mt.)	Total Proposed Built Up Area (Sq.mt.)	Total FAR Area (Sq.mt.)
Ground Floor	104.30	104.30	104.30	104.30
First Floor	104.27	104.27	104.27	104.27
Terrace Floor	0.00	0.00	0.00	0.00
Total :	208.57	208.57	208.57	208.57

Building Name	Building Use	Building SubUse	Building Structure
AA (BB)	Residential	Bungalow/ Dwelling / Non Apartment	Non-Highrise

Building	No. of Same Bldg	Total Built Up Area (Sq.mt.)	Proposed FAR Area (Sq.mt.)	Total FAR Area (Sq.mt.)	Total Consumed Additional FAR Area (Sq.mt.)	Trmt (No.)
AA (BB)	1	208.57	208.57	208.57	208.57	01
Grand Total :	1	208.57	208.57	208.57	208.57	01

FLOOR	Name	UnitBUA Type	UnitBUA Area	Carpet Area	No. of Rooms	No. of Tenement
GROUND FLOOR PLAN	SPLIT ABC	FLAT	208.57	208.48	5	1
FIRST FLOOR PLAN	SPLIT ABC	FLAT	0.00	0.00	8	0
Total:	-	-	208.57	208.48	13	1

Floor Name	Total Built Up Area (Sq.mt.)	Proposed FAR Area (Sq.mt.) Resi.	Total FAR Area (Sq.mt.)	Total Consumed Additional FAR Area (Sq.mt.)	Trmt (No.)
Ground Floor	104.30	104.30	104.30	104.30	01
First Floor	104.27	104.27	104.27	104.27	00
Terrace Floor	0.00	0.00	0.00	0.00	00
Total :	208.57	208.57	208.57	208.57	01
Total Number of Same Buildings :	1				
Total :	208.57	208.57	208.57	208.57	01

BUILDING NAME	NAME	LENGTH	HEIGHT	NOS
AA (BB)	D	0.76	2.10	05
AA (BB)	D	0.99	2.10	01
AA (BB)	D	1.10	2.10	02
AA (BB)	D	1.22	2.10	02
AA (BB)	D	1.23	2.10	02

BUILDING NAME	NAME	LENGTH	HEIGHT	NOS
AA (BB)	W	0.61	1.20	02
AA (BB)	W	0.74	1.20	02
AA (BB)	W	0.91	1.20	02
AA (BB)	W	1.22	1.20	07

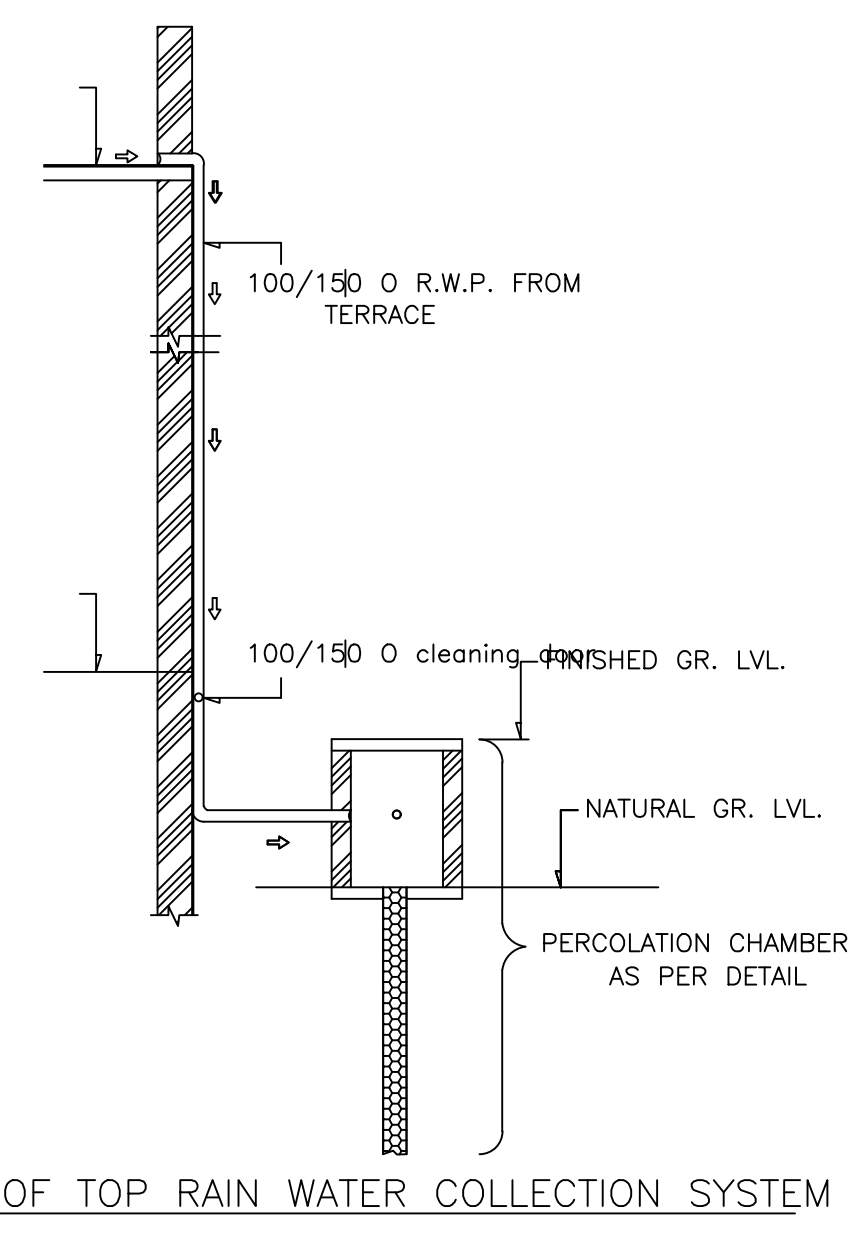
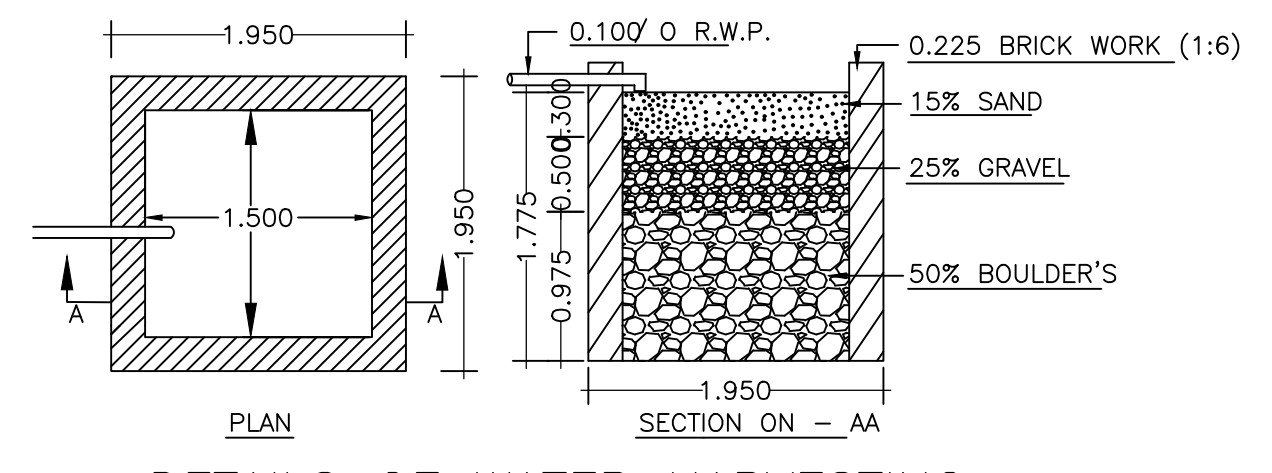
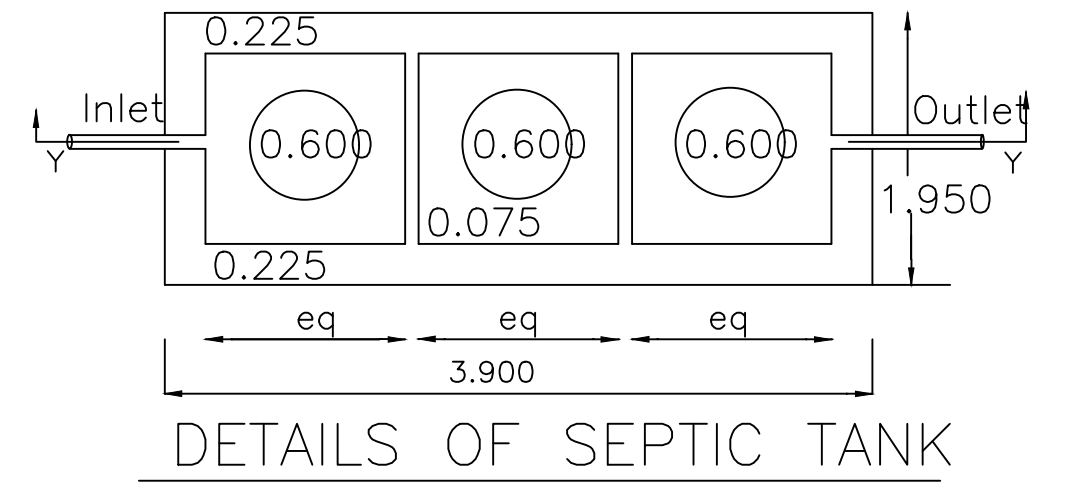
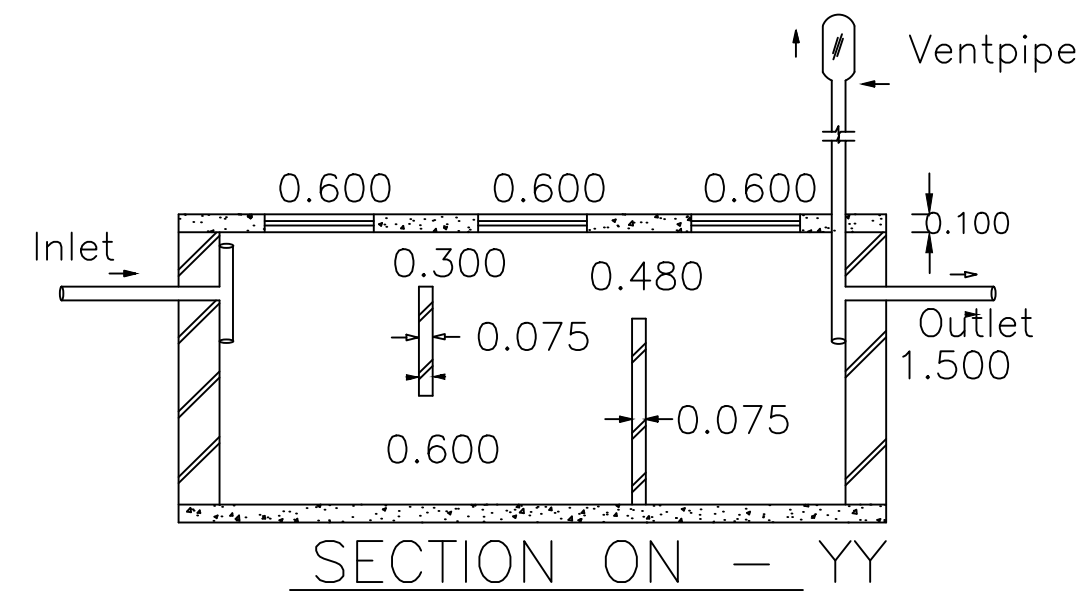

LTP NAME AND SIGNATURE	STRUCTURAL ENG'S NAME AND SIGNATURE	BUILDER NAME AND SIGNATURE	DIGITAL SIGNATURE
ABHISHEK KUMAR DMC/DFTMN/0013/2020			

Proposal Basic Information	
Proposal File No.	DMC/BP/0054/W21/2021
Owner Name	SMT SUNITA DEVI
Khata No	110
Plot No	1985
Village Name	Dhaiya
Use	Residential
SubUse	Semidetached

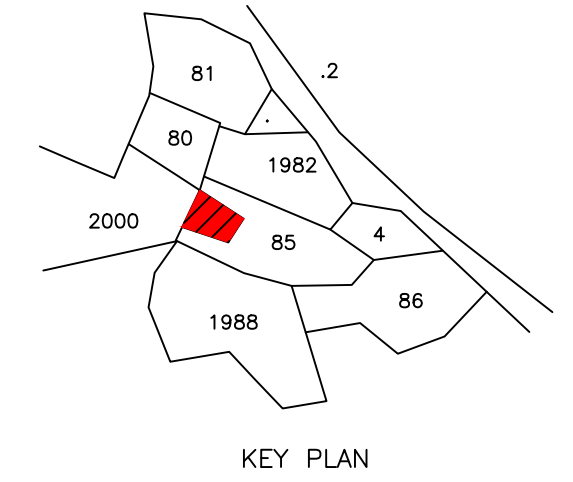
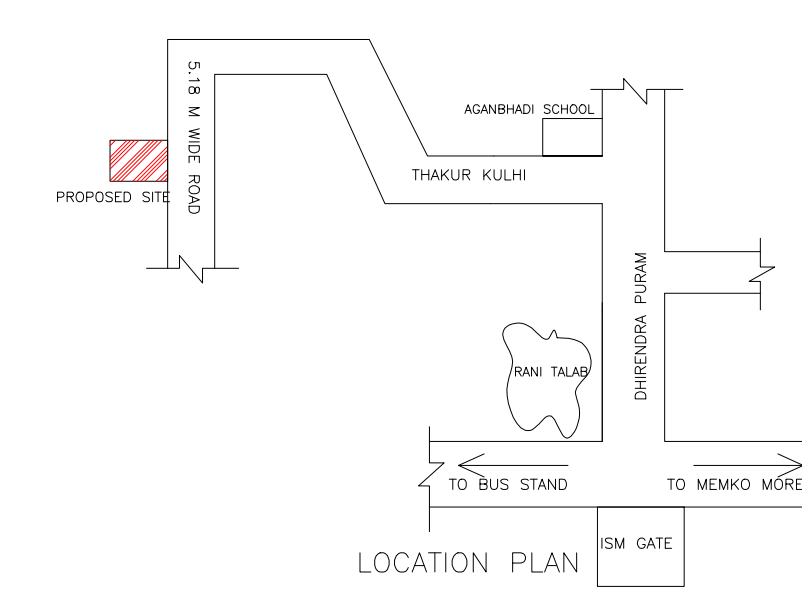
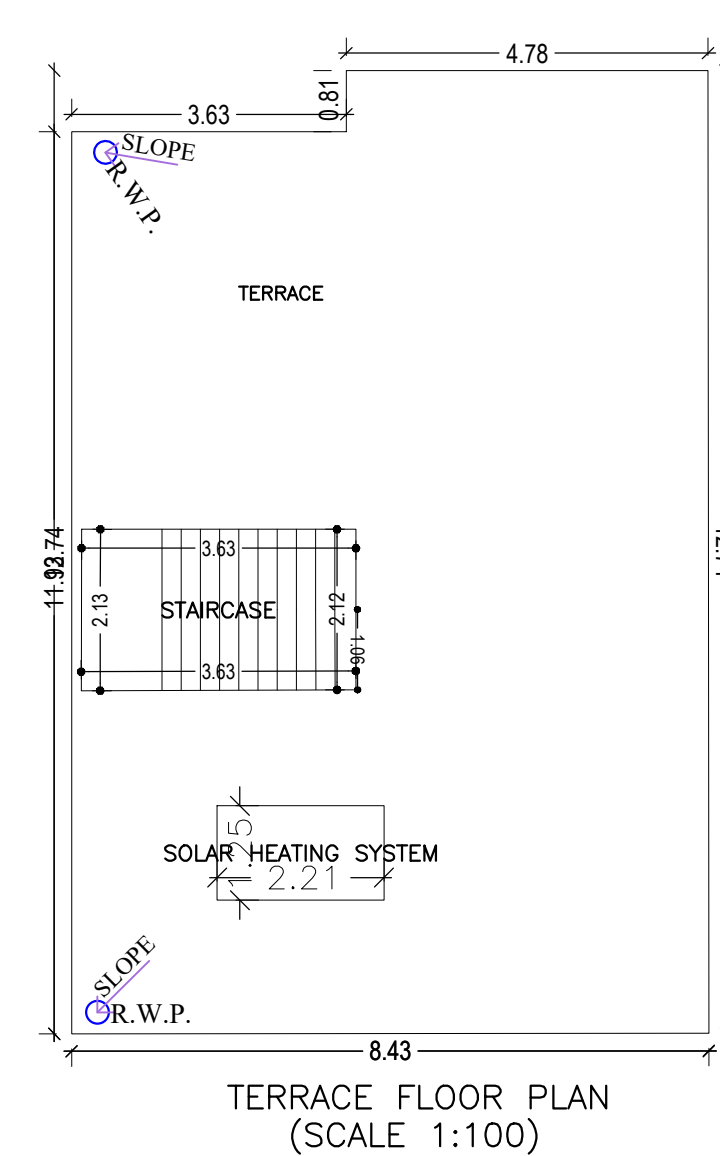
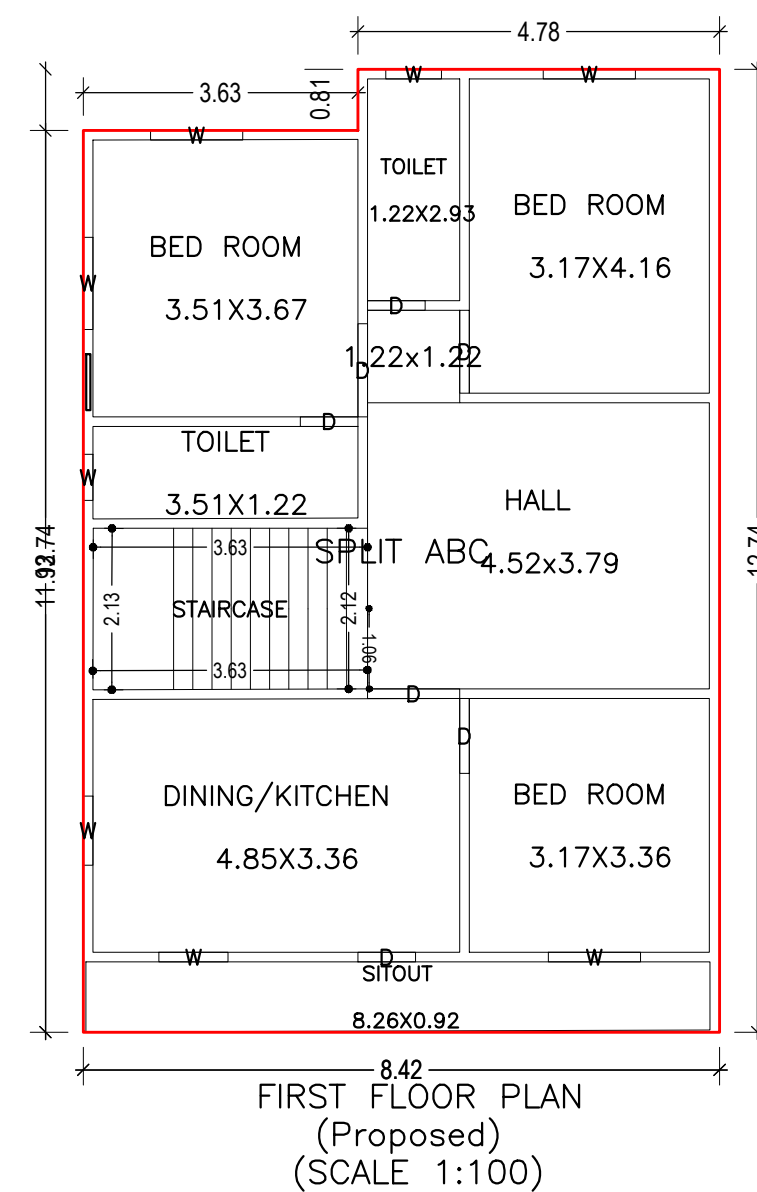
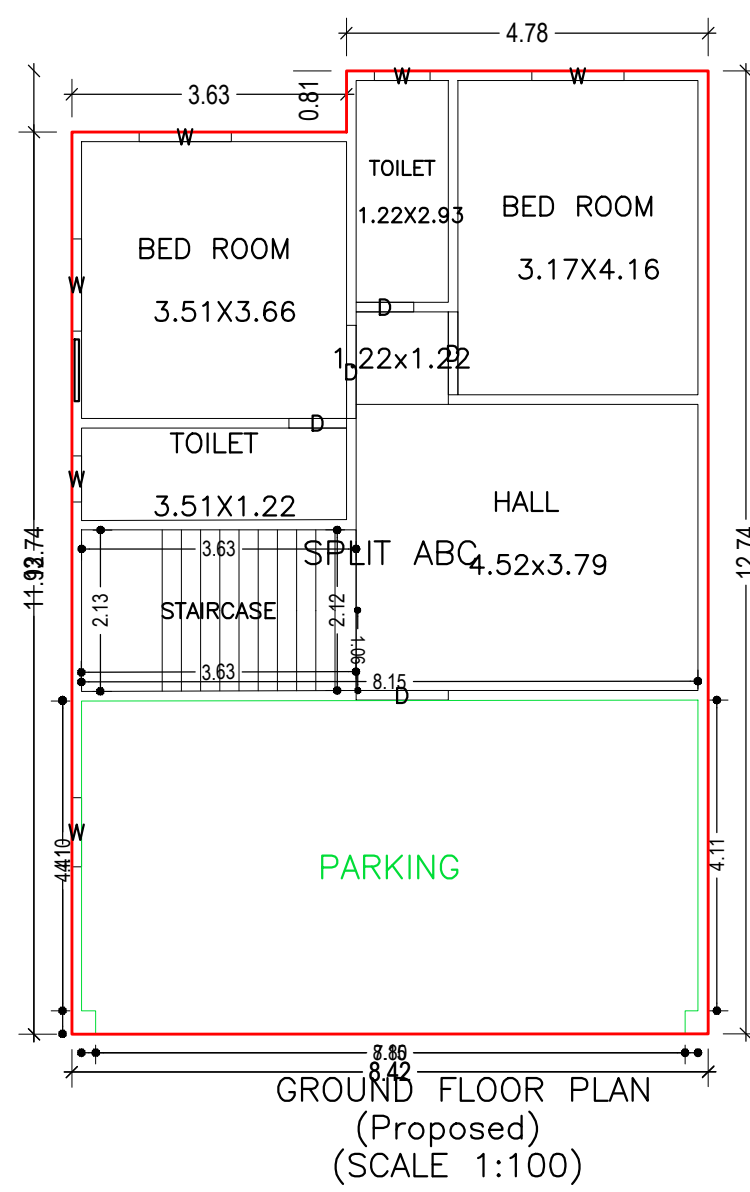
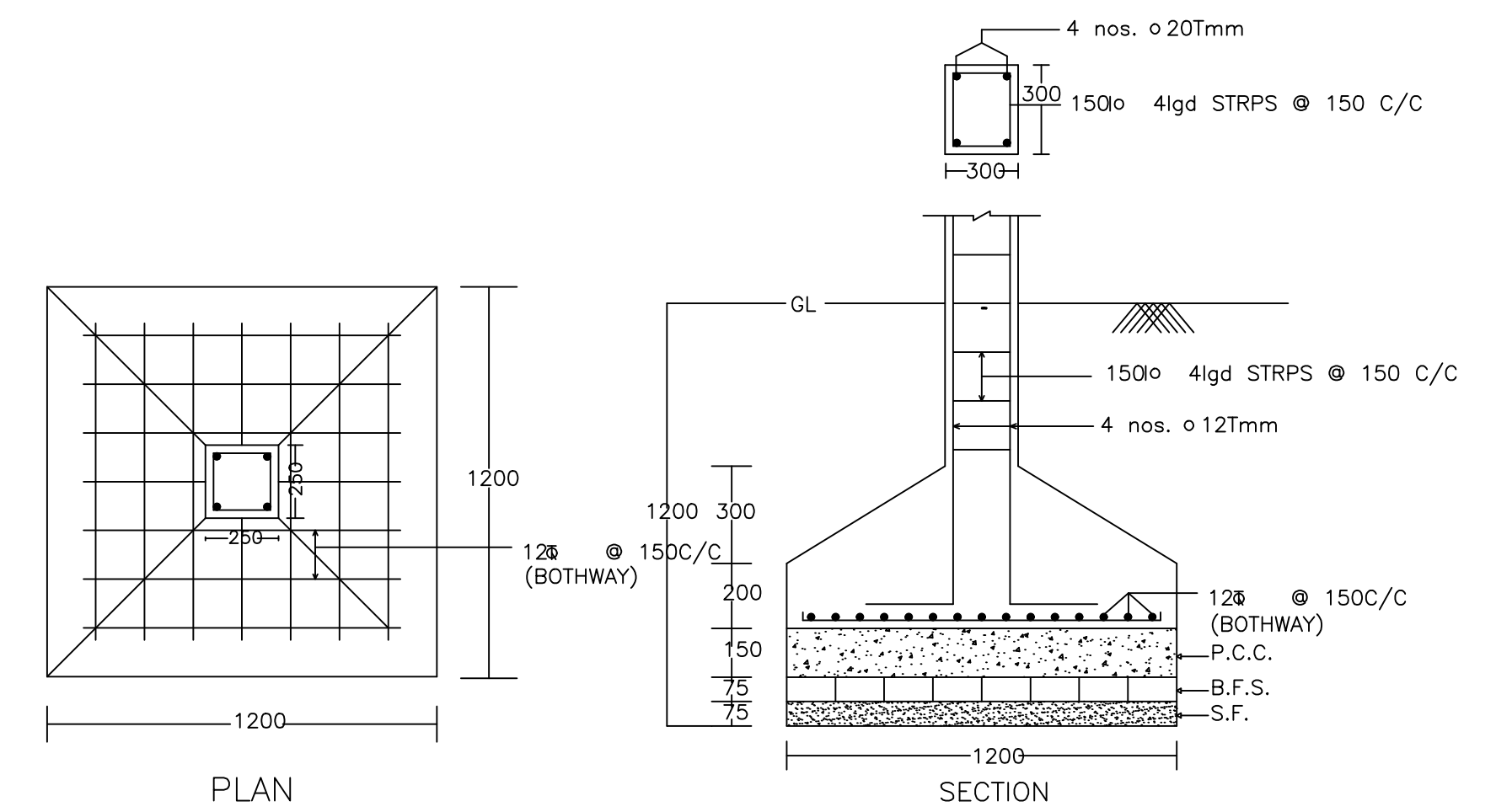
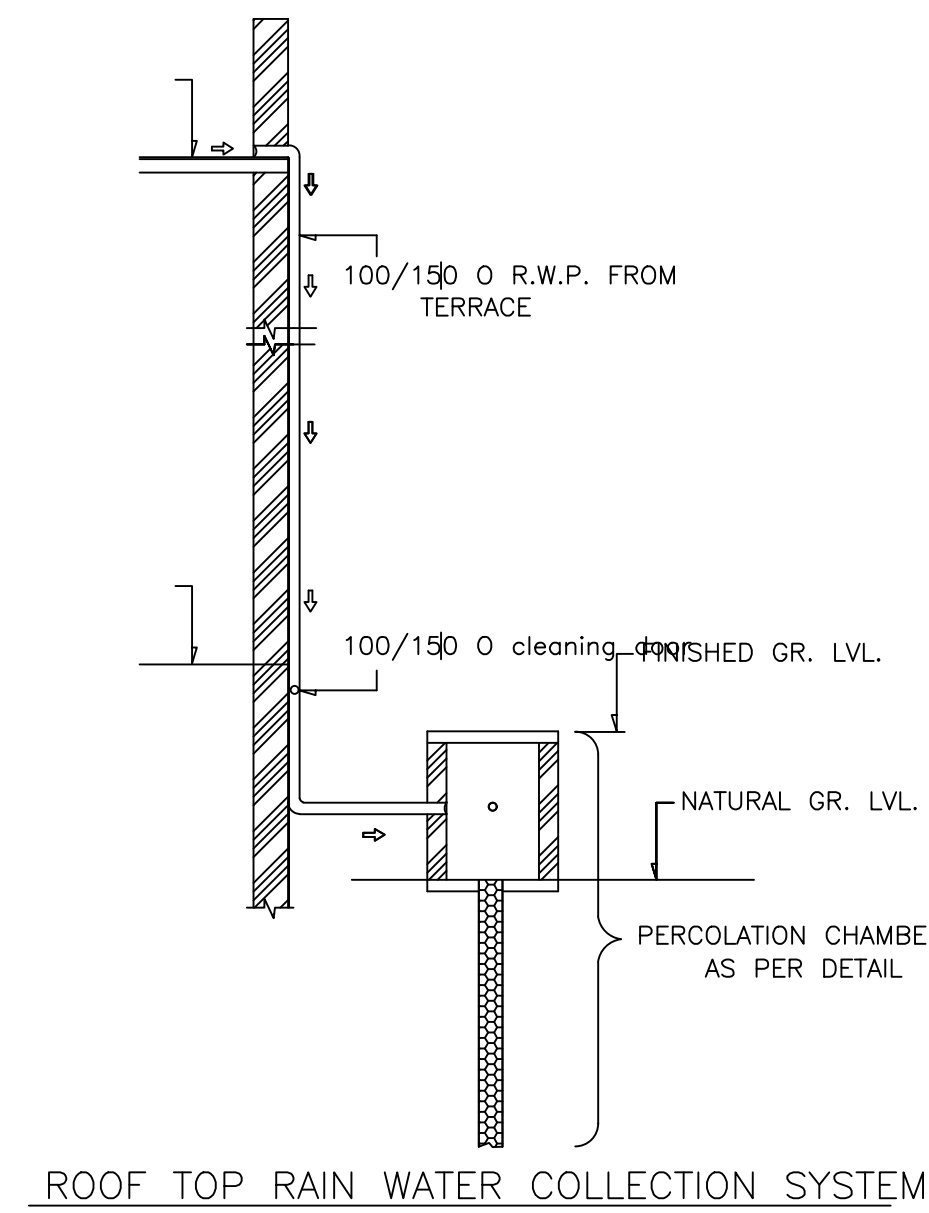
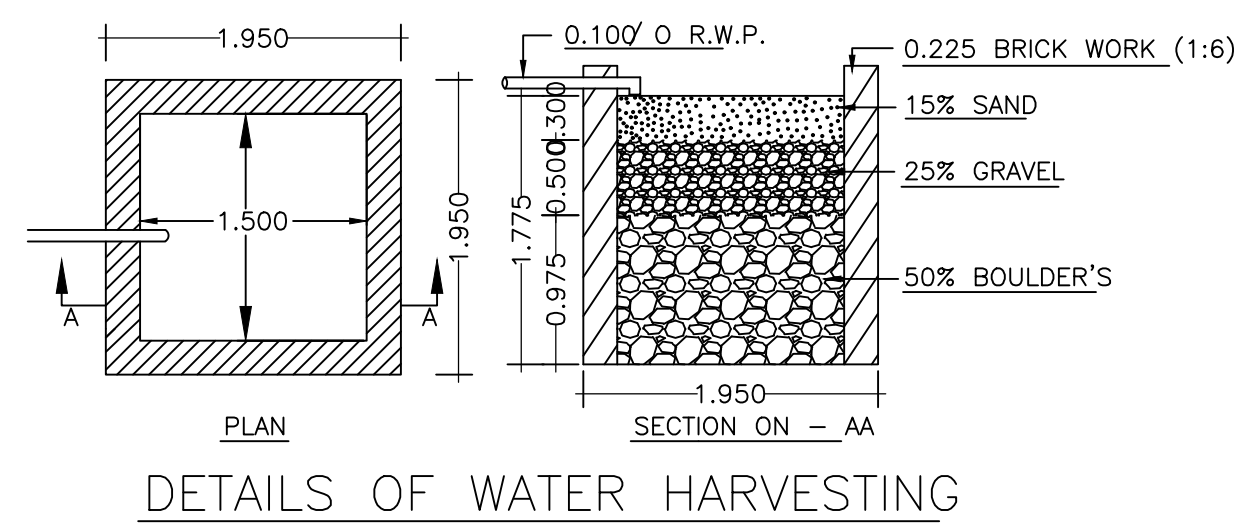
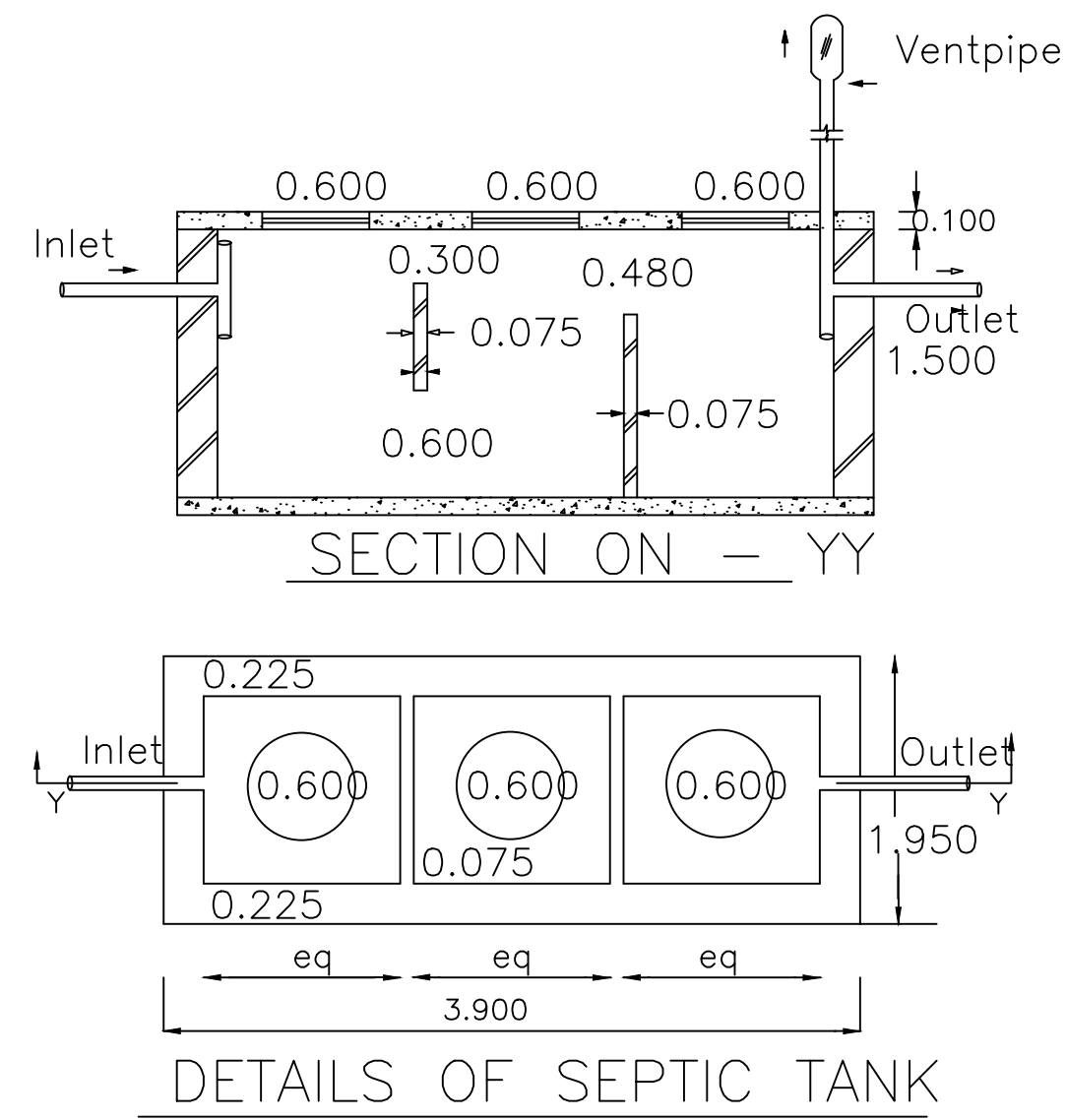
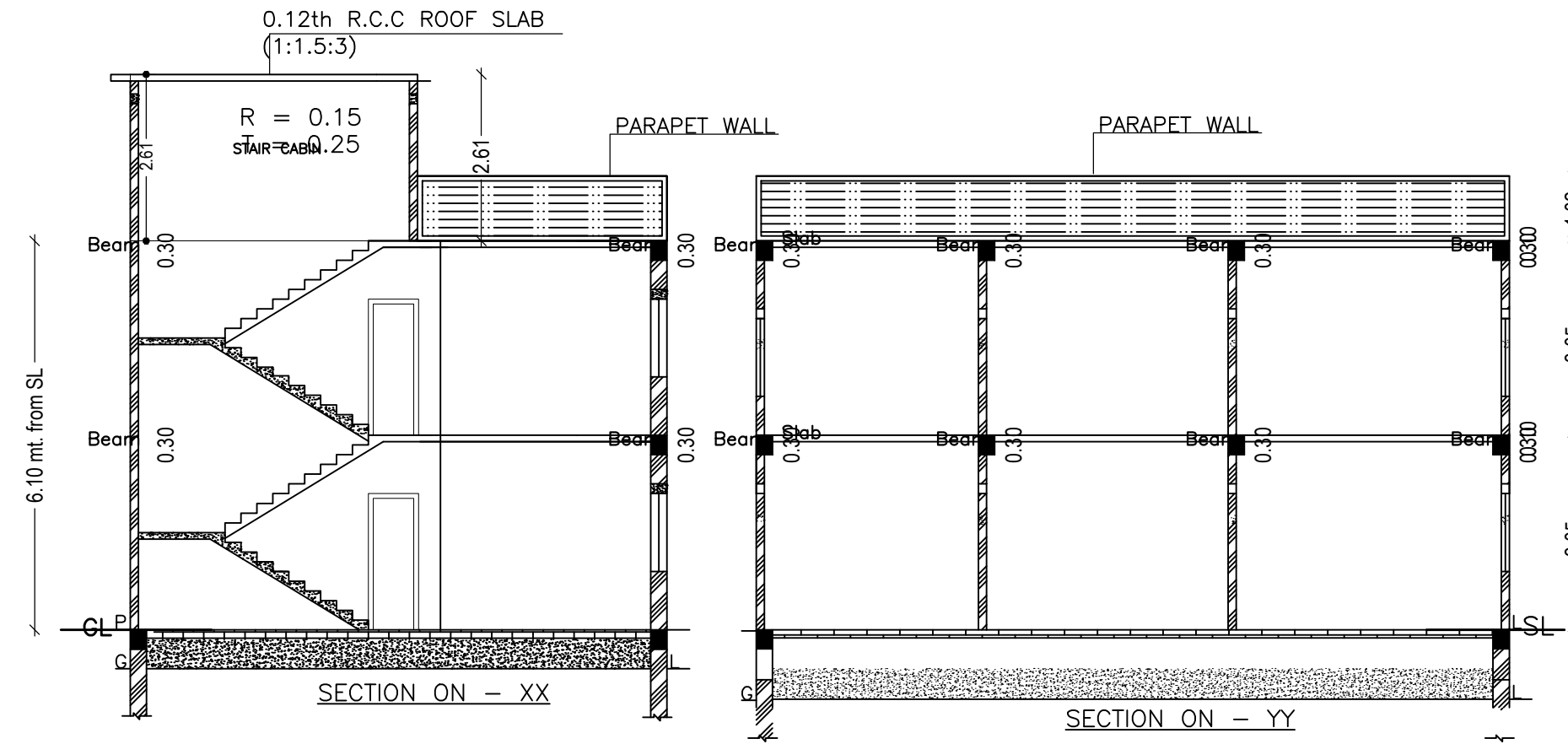
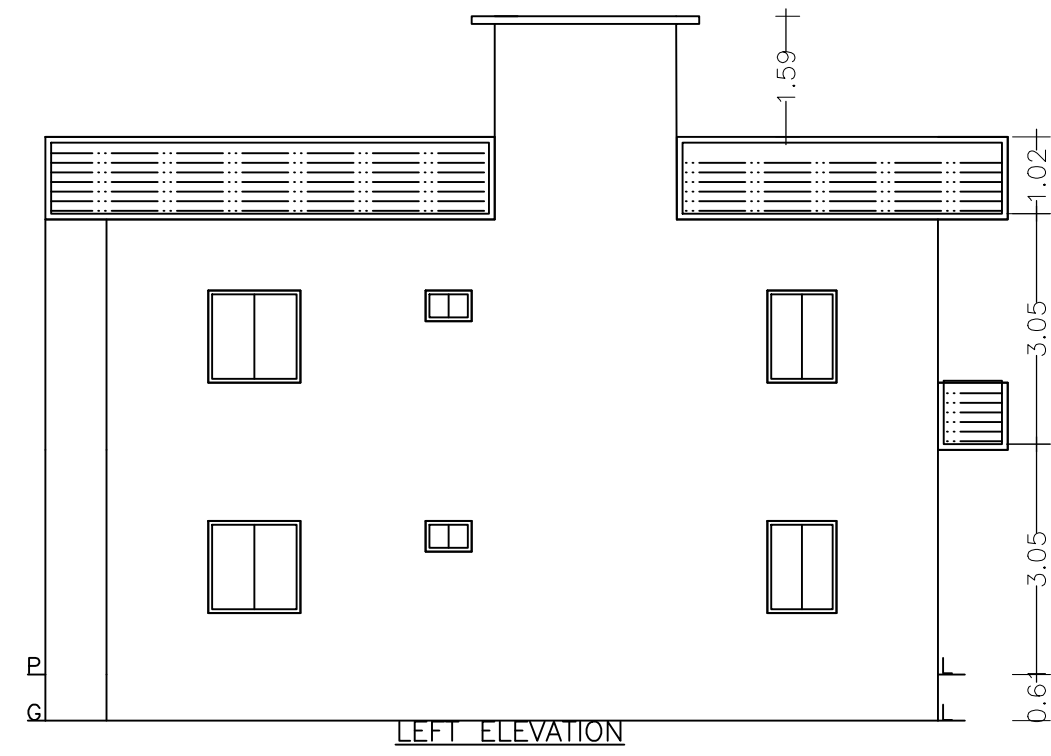
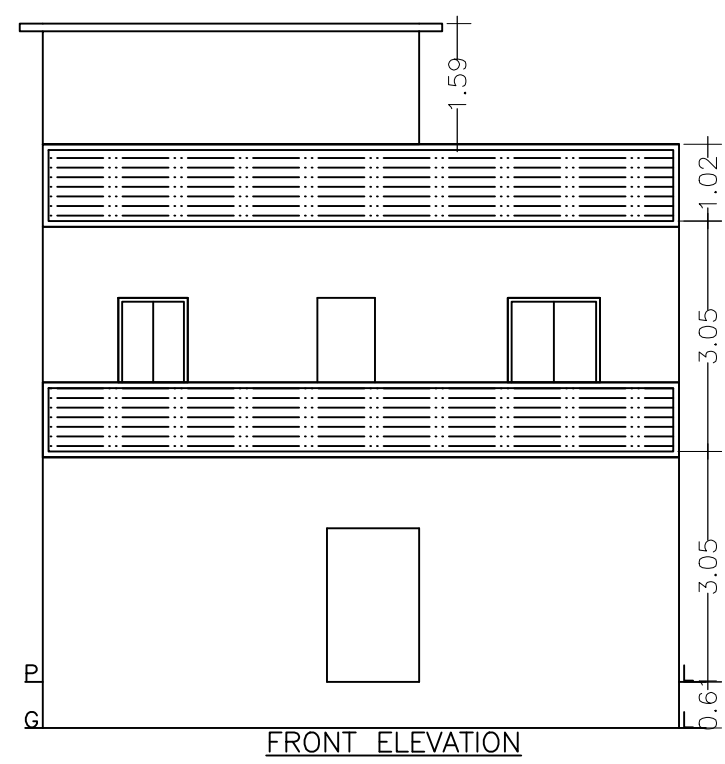

LTP NAME AND SIGNATURE	STRUCTURAL ENG'S NAME AND SIGNATURE	BUILDER NAME AND SIGNATURE	DIGITAL SIGNATURE
ABHISHEK KUMAR DMC/FTMN/0013/2020			