

SITE PLAN

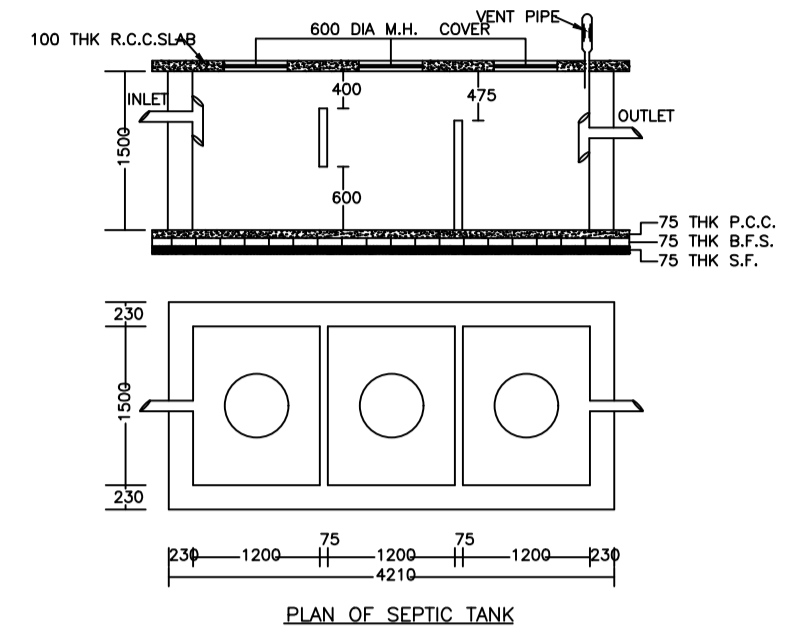

PLAN OF SEPTIC TANK

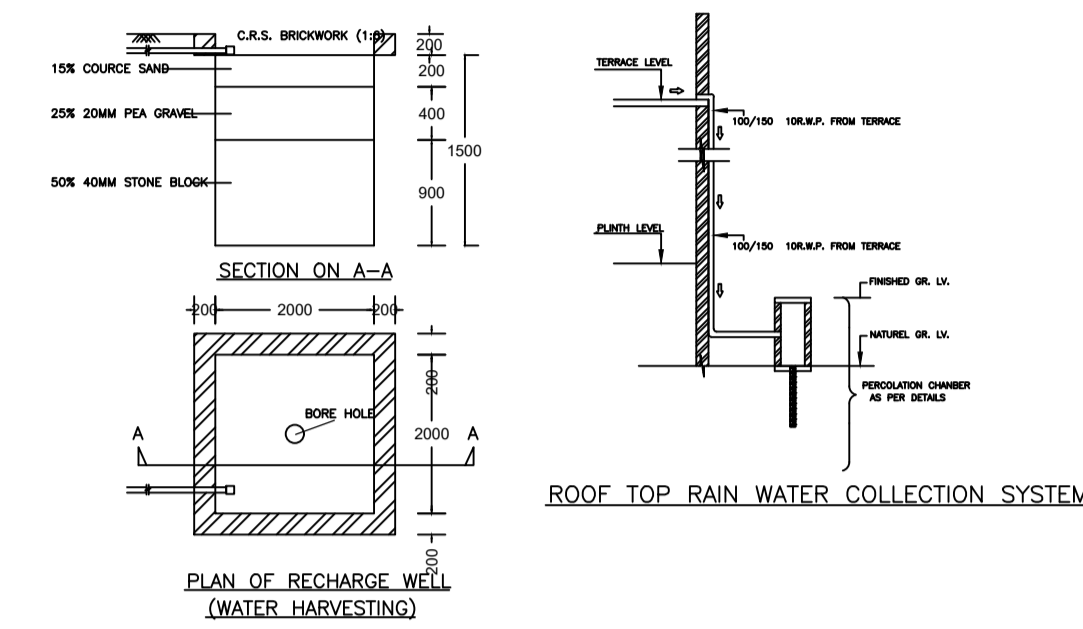

ROOF TOP RAIN WATER COLLECTION SYSTEM

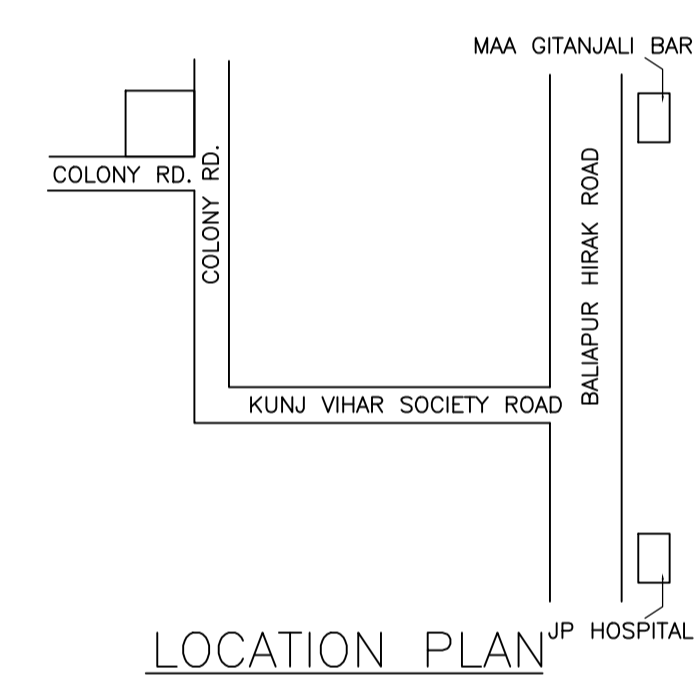

LOCATION PLAN

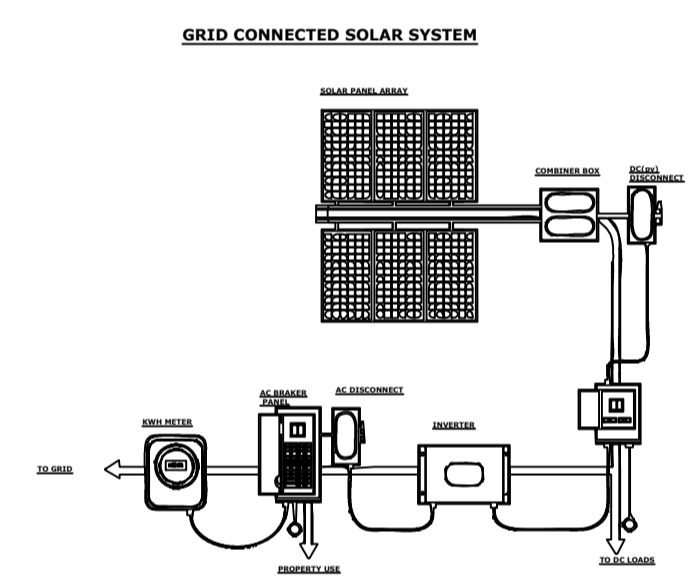

GRID CONNECTED SOLAR SYSTEM

Proposal Basic Information

Proposal File No.	DMC/BP/0072/W23/2021
Owner Name	Smt Suman Kumari
Khata No	49 (OLD), New Khata - 590
Plot No	3204 (OLD), NEW PLOT NO.- 3921
Village Name	Kolakusma
Use	Residential
SubUse	Bungalow/ Dwelling / Non Apartment

AREA STATEMENT	VERSION NO.: 1.0.55
DHANBAD MUNICIPAL CORPORATION	VERSION DATE: 16/10/2020
PROJECT DETAIL:	
Region: JHARKHAND URBAN LOCAL BODIES	Plot Use: Residential
District: DHANBAD	Plot SubUse: Bungalow/ Dwelling / Non Apartment
Authority: DHANBAD MUNICIPAL CORPORATION	Plot/Nearby/Religious/Structure: NA
Inward No: DMC/BP/0072/W23/2021	Plot/SubPlot No: 3204 (OLD), NEW PLOT NO.- 3921
Application Type: General Proposal	North: Plot No. - PART OF PLOT NO 3204
Project Type: Building Permission	South: Road Width - 5.48M WIDE PROPOSED ROAD
Nature of Development: New	East: Road Width - 5.48M WIDE PROPOSED ROAD
Location of Development Area: Old Area	West: Plot No. - PART OF PLOT NO 3204
AREA DETAILS:	SQ.MT.
AREA OF PLOT (Minimum)	(A)
NET AREA OF PLOT(Gross Plot Area - Deduction from Gross Plot area)	197.70
Deduction for Balance Plot Area(from Gross Plot Area)	
Common Plot	16.44
Total	16.44
BALANCE AREA OF PLOT(Net Plot Area - Recreational/Amenity space)	(A-Deductions) 181.26
PLOT AREA FOR COVERAGE(Net Plot Area)	(A-Deductions) 197.70
Plot Area for FAR (Net Plot Area + Road/Widening Area)	(A-Deductions) 197.70
COVERAGE CHECK	
Permissible Coverage area ( 70.00 % )	138.39
Proposed Coverage Area ( 58.01 % )	114.69
Total Prop. Coverage Area ( 58.01 % )	114.69
Balance coverage area ( 11.99 % )	23.70
FAR CHECK	
Perm. FAR Area ( 1.80 )	355.86
Total Perm. FAR area	355.86
Residential FAR	242.13
Proposed FAR Area	242.13
Total Proposed FAR Area	242.13
Consumed FAR (Factor)	1.22
Balance FAR Area	113.73
BUILT UP AREA CHECK	
Total Proposed BuiltUp Area	242.14
ARCHITECT (Regd)	AMRESH KUMAR BHARTI
ENGINEER (Regd)	
SUPERVISOR (Regd)	
OWNER (Regd)	Smt Suman Kumari
DEVELOPMENT AUTHORITY LOCAL BODY	

COLOR INDEX	
PLOT BOUNDARY	Black
ABUTTING ROAD	Green
PROPOSED CONSTRUCTION	Red
COMMON PLOT	Yellow
ROAD WIDENING AREA	Orange
EXISTING (To be retained)	Blue
EXISTING (To be demolished)	Light Blue

Buildingwise Floor FAR Details

Floor Name	Building Name		Total	
	A (SMT SUMAN KUMARI)	Total Proposed Built Up Area (Sq.mt.)	Total FAR Area (Sq.mt.)	Total FAR Area (Sq.mt.)
Ground Floor	114.69	114.69	114.69	114.69
First Floor	127.45	127.45	127.45	127.45
Terrace Floor	0.00	0.00	0.00	0.00
Total	242.14	242.14	242.14	242.14

Building USE/SUBUSE Details

Building Name	Building Use	Building SubUse	Building Structure
A (SMT SUMAN KUMARI)	Residential	Bungalow/ Dwelling / Non Apartment	Non-Highrise

FAR & Tenement Details (Table 4c-1)

Building	No. of Same Bldg	Total Built Up Area (Sq.mt.)	Proposed FAR Area (Sq.mt.)	Total FAR Area (Sq.mt.)	Total Consumed Additional FAR Area (Sq.mt.)	Tnmt (No.)
A (SMT SUMAN KUMARI)	1	242.14	242.14	242.14	242.14	01
Grand Total:	1	242.14	242.14	242.14	242.14	01

UnitBUA Table for Building :A (SMT SUMAN KUMARI)

FLOOR	Name	UnitBUA Type	UnitBUA Area	Carpet Area	No. of Rooms	No. of Tenement
GROUND FLOOR PLAN	SPLIT 1	FLAT	242.13	241.96	9	1
FIRST FLOOR PLAN	SPLIT 1	FLAT	0.00	0.00	12	0
Total:	-	-	242.13	241.96	21	1

SCHEDULE OF DOOR:

BUILDING NAME	NAME	LENGTH	HEIGHT	NOS
A (SMT SUMAN KUMARI)	D2	0.75	2.10	05
A (SMT SUMAN KUMARI)	D1	0.90	2.10	04
A (SMT SUMAN KUMARI)	D	1.00	2.10	12
A (SMT SUMAN KUMARI)	D	1.05	2.10	01

SCHEDULE OF WINDOW/VENTILATION:

BUILDING NAME	NAME	LENGTH	HEIGHT	NOS
A (SMT SUMAN KUMARI)	V	0.60	0.60	04
A (SMT SUMAN KUMARI)	W1	0.90	1.20	06
A (SMT SUMAN KUMARI)	W	1.20	1.20	15

Building :A (SMT SUMAN KUMARI)

Floor Name	Total Built Up Area (Sq.mt.)	Proposed FAR Area (Sq.mt.)	Total FAR Area (Sq.mt.)	Total Consumed Additional FAR Area (Sq.mt.)	Tnmt (No.)
Ground Floor	114.69	114.69	114.69	114.69	01
First Floor	127.45	127.45	127.45	127.45	00
Terrace Floor	0.00	0.00	0.00	0.00	00
Total:	242.14	242.14	242.14	242.14	01
Total Number of Same Buildings	1				
Total:	242.14	242.14	242.14	242.14	01

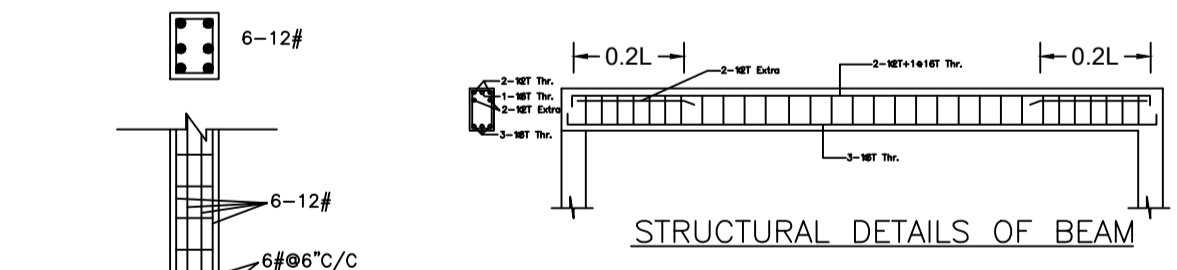

STRUCTURAL DETAILS OF BEAM

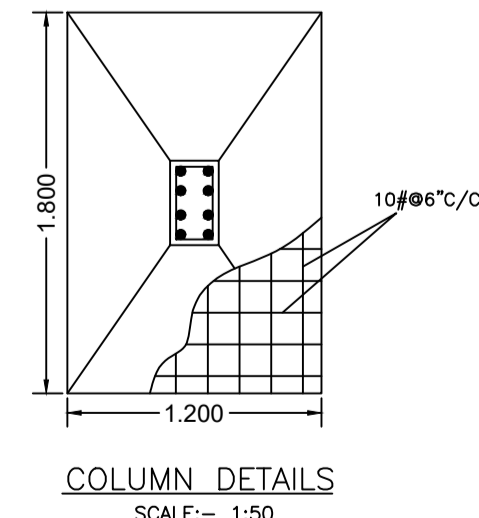

COLUMN DETAILS

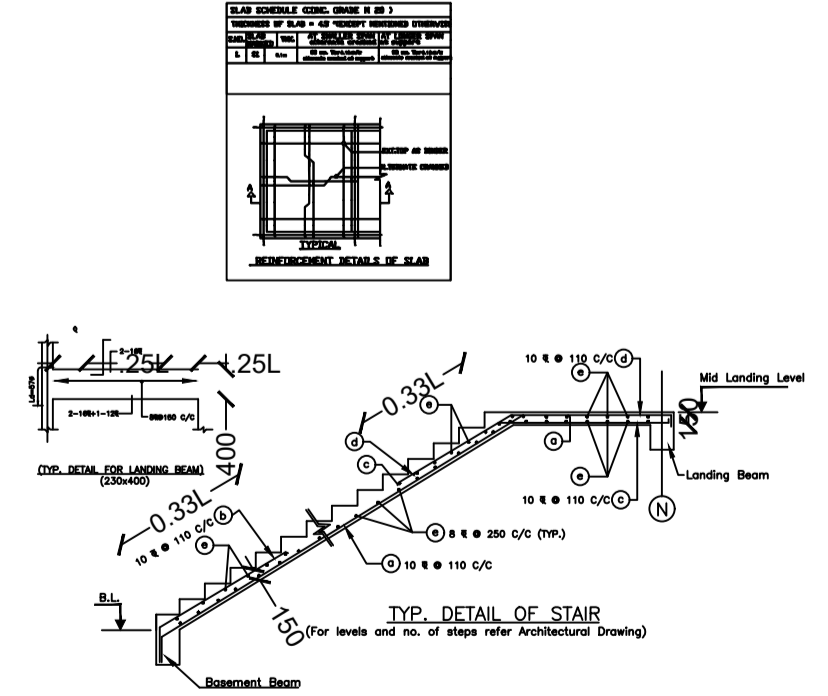

TYP. DETAIL OF STAIR

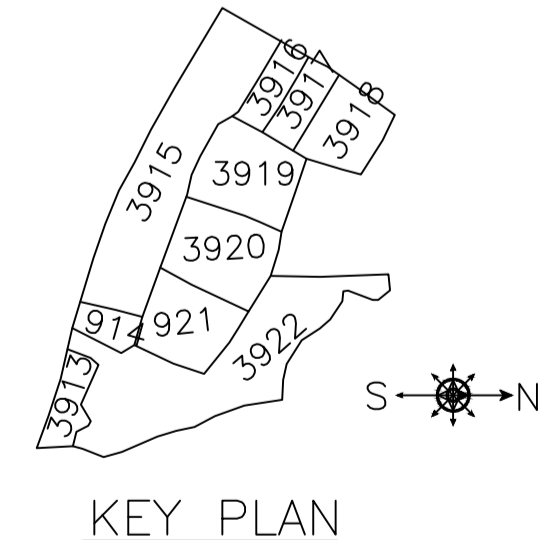

KEY PLAN

Proposal Basic Information

Proposal File No.	DMC/BP/0072/W23/2021
Owner Name	Smt Suman Kumari
Khata No	49 (OLD), New Khata - 590
Plot No	3204 (OLD), NEW PLOT NO.-3921
Village Name	Kolakusma
Use	Residential
SubUse	Bungalow/ Dwelling / Non Apartment



FRONT ELEVATION

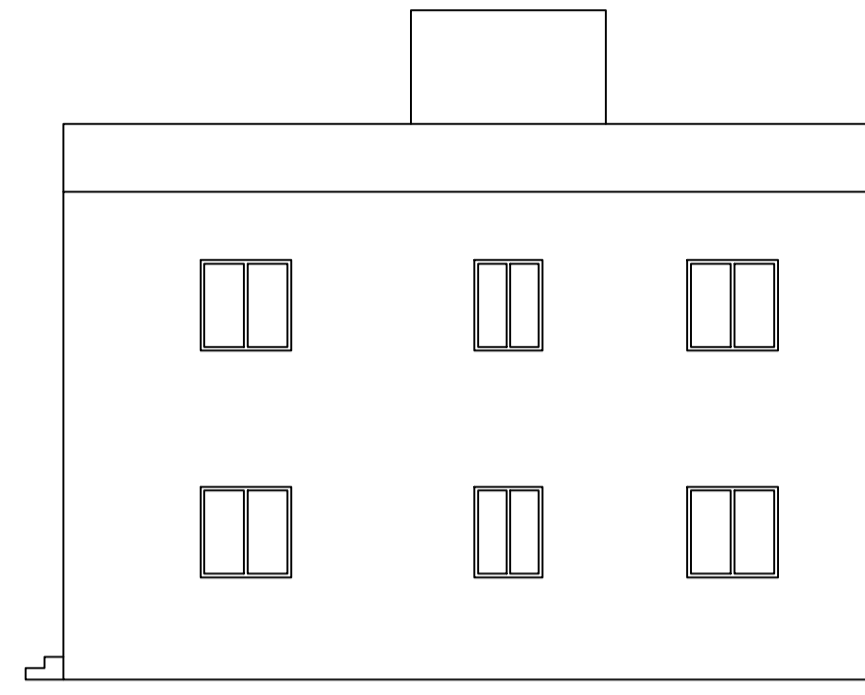

LEFT SIDE ELEVATION

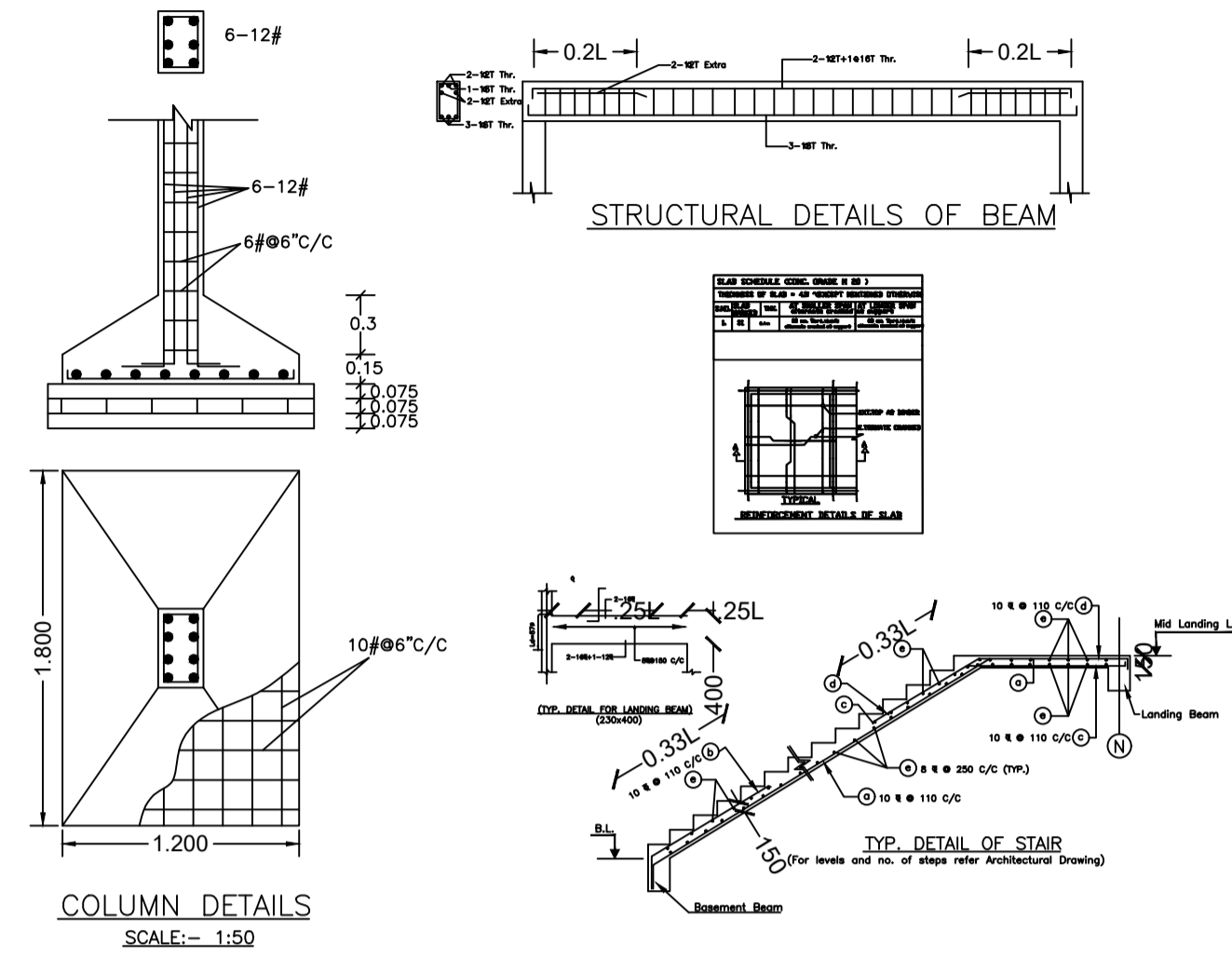

COLUMN DETAILS  
SCALE: 1:50

STRUCTURAL DETAILS OF BEAM

TYP. DETAIL OF STAIR

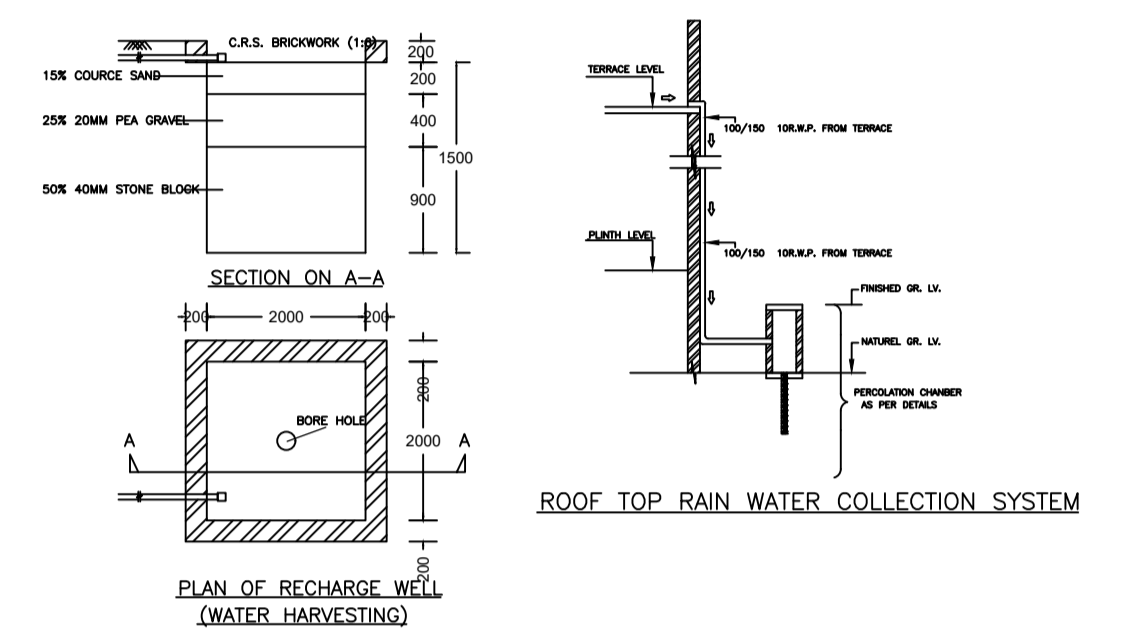

ROOF TOP RAIN WATER COLLECTION SYSTEM

PLAN OF RECHARGE WELL (WATER HARVESTING)

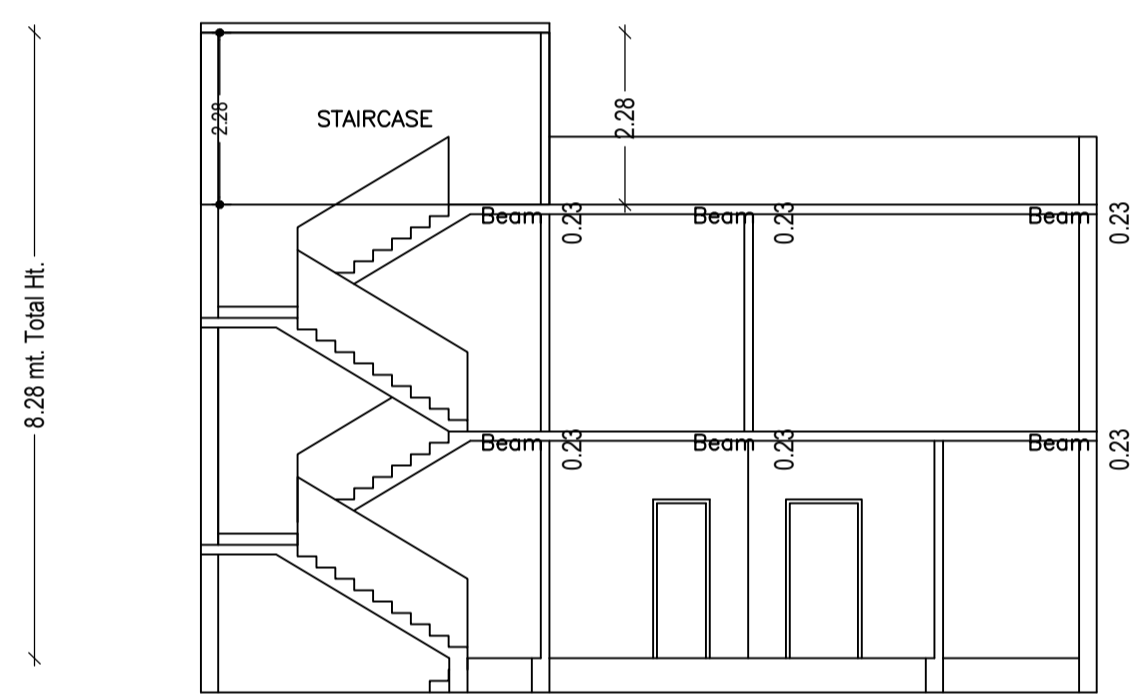

SECTION ON X-X

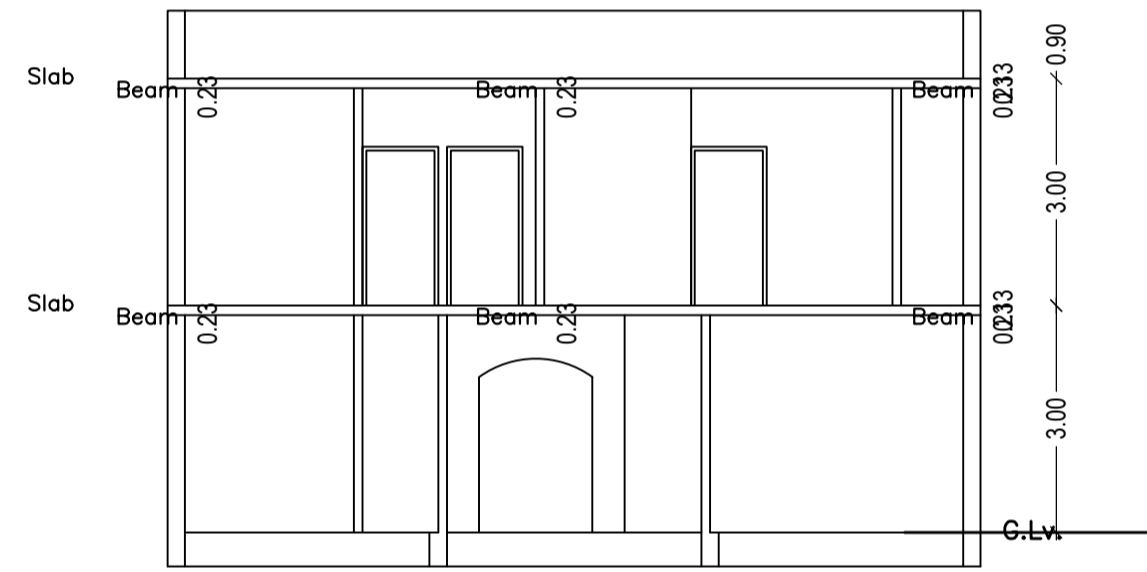

SECTION ON Y-Y

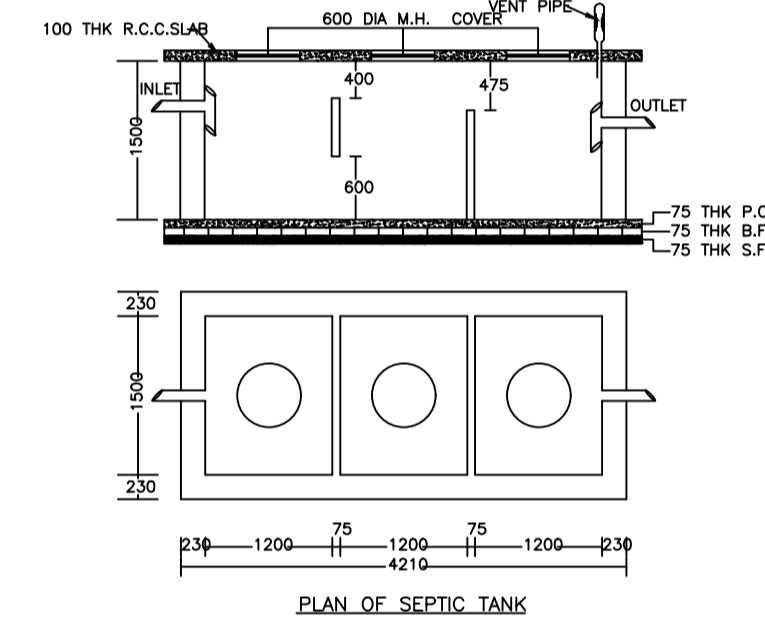

PLAN OF SEPTIC TANK

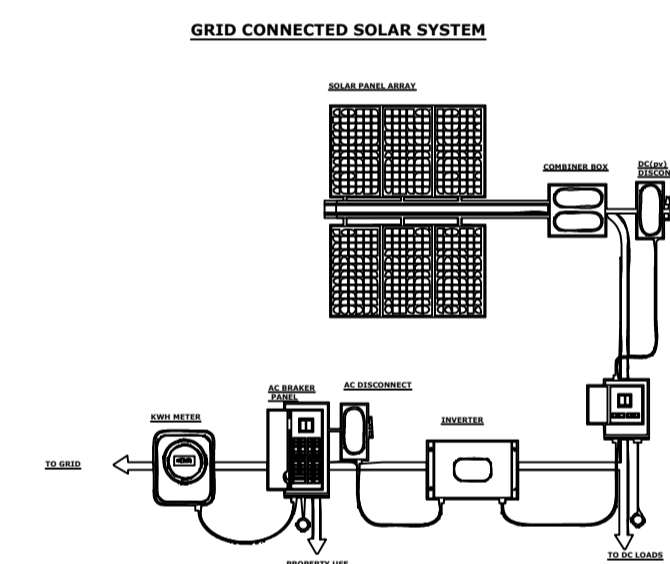

GRID CONNECTED SOLAR SYSTEM

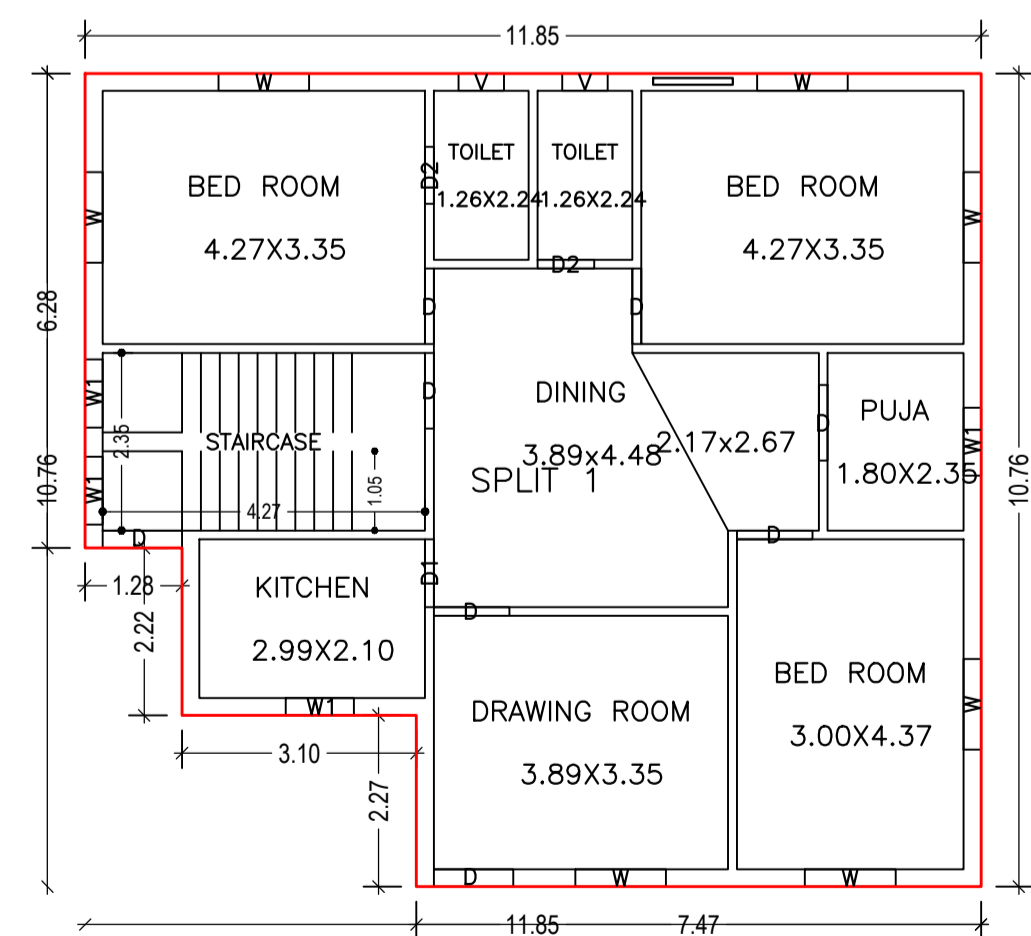

GROUND FLOOR PLAN  
(Proposed)  
(SCALE 1:100)

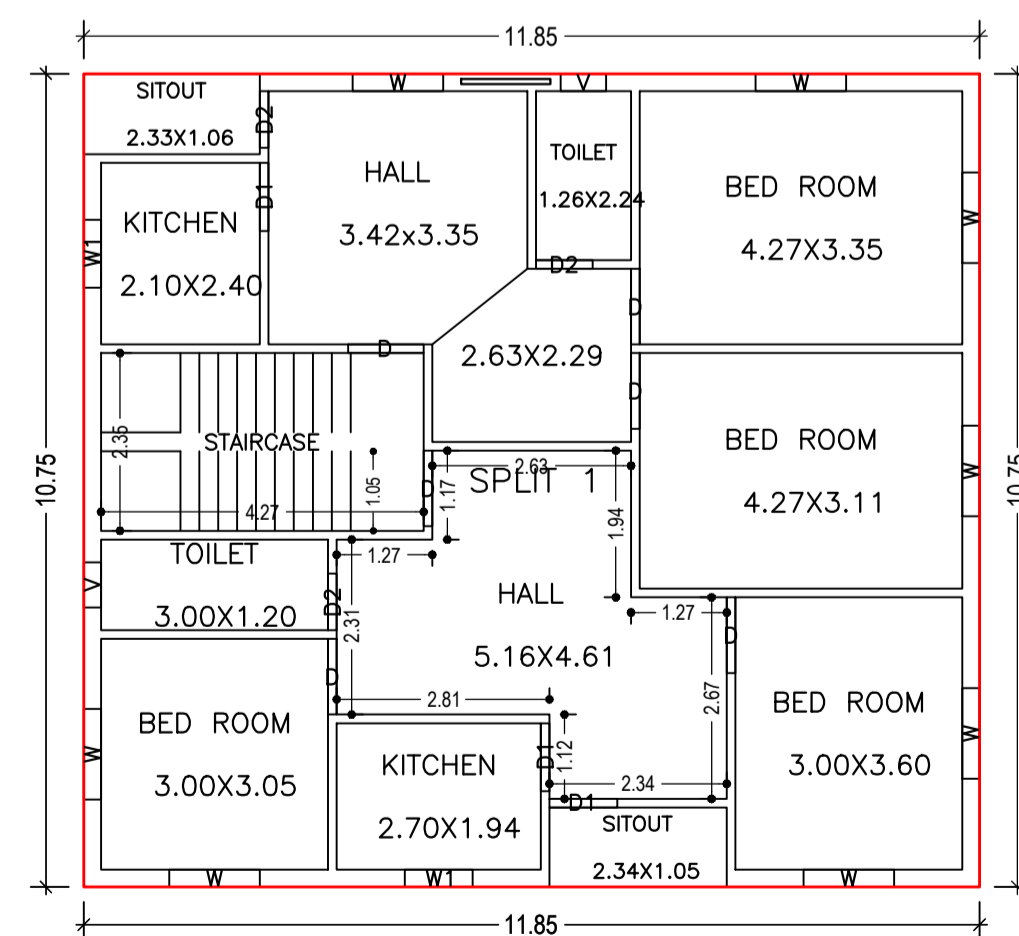

FIRST FLOOR PLAN  
(Proposed)  
(SCALE 1:100)

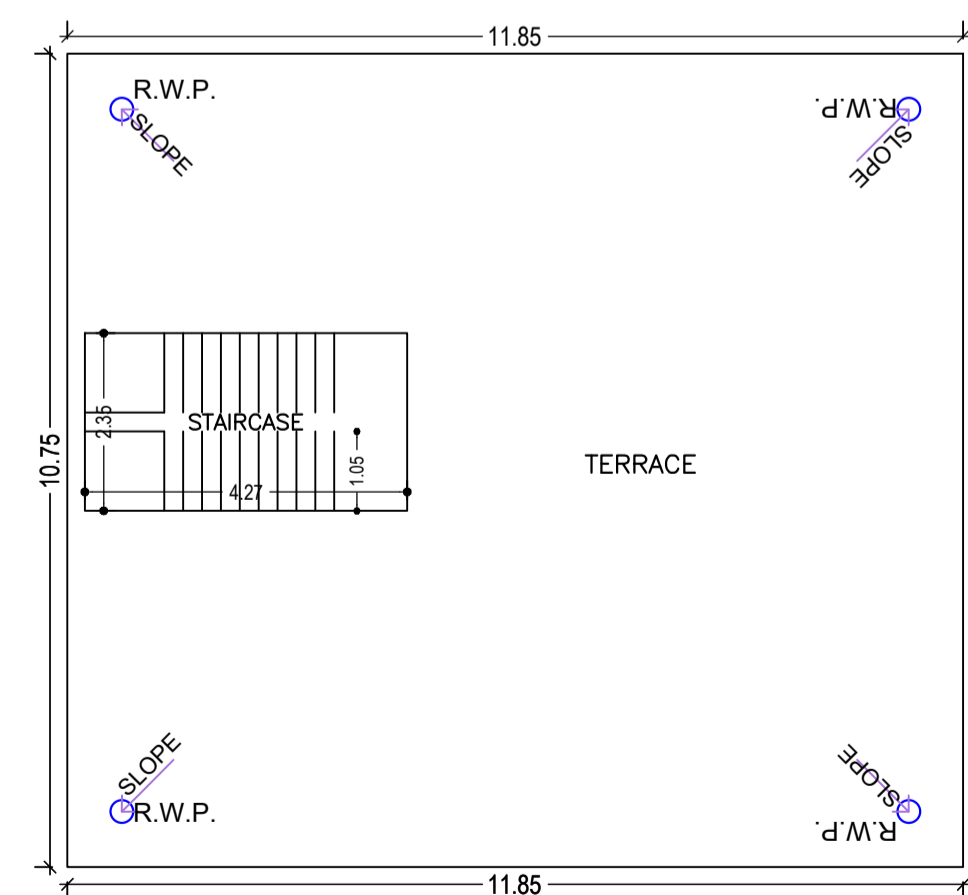

TERRACE FLOOR PLAN  
(SCALE 1:100)

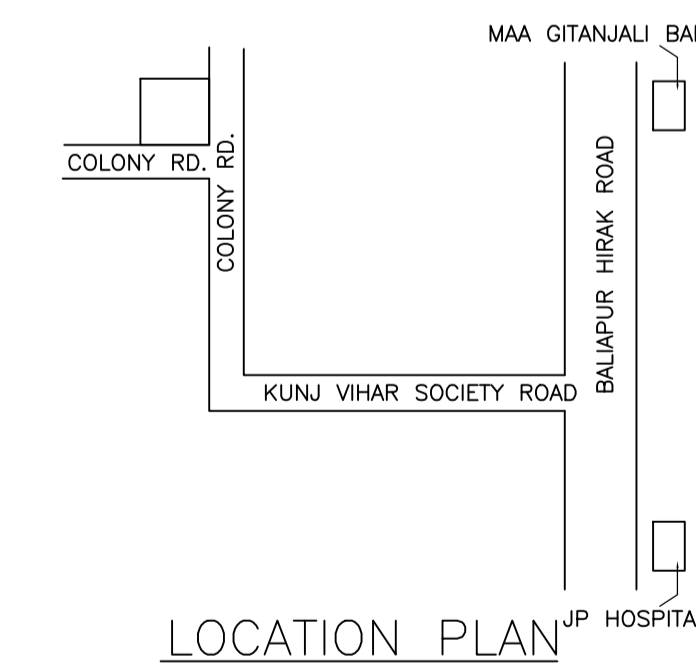

LOCATION PLAN

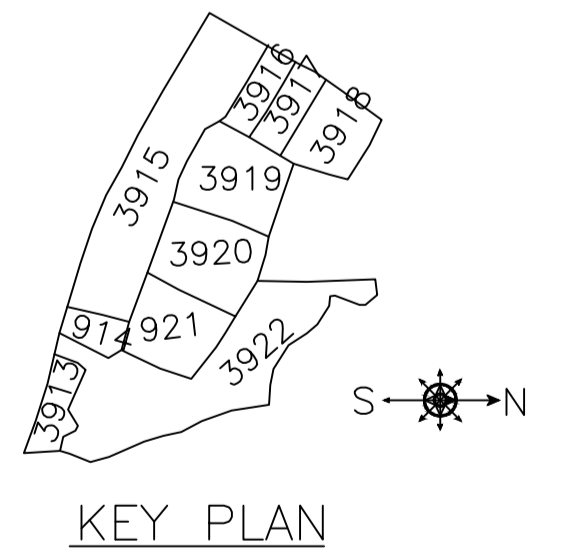

KEY PLAN

LTP NAME AND SIGNATURE	STRUCTURAL ENG'S NAME AND SIGNATURE	BUILDER NAME AND SIGNATURE	DIGITAL SIGNATURE
AMRESH KUMAR BHARTI DMC/ENG/0022/2016			