

Proposal Basic Information

Proposal File No.	DMC/BP/0090/W30/2021
Owner Name	AJAY KUMAR MAHTO
Khata No	OLD-122,NEW-16
Plot No	OLD-398, NEW-436
Village Name	Patrakulhi
Use	Residential
SubUse	Bungalow/ Dwelling / Non Apartment

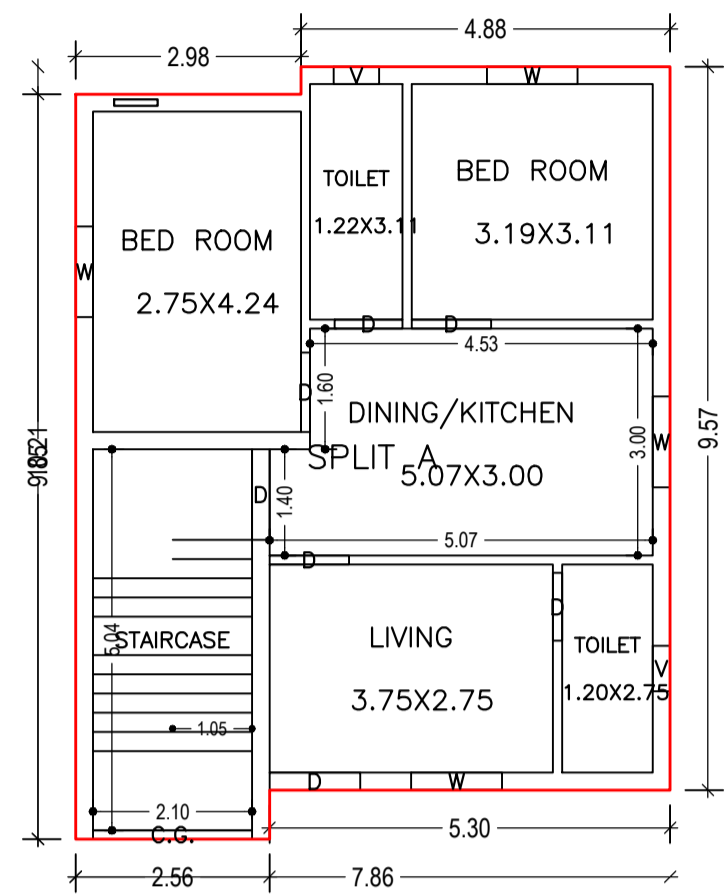

GROUND FLOOR PLAN (Proposed) (SCALE 1:100)

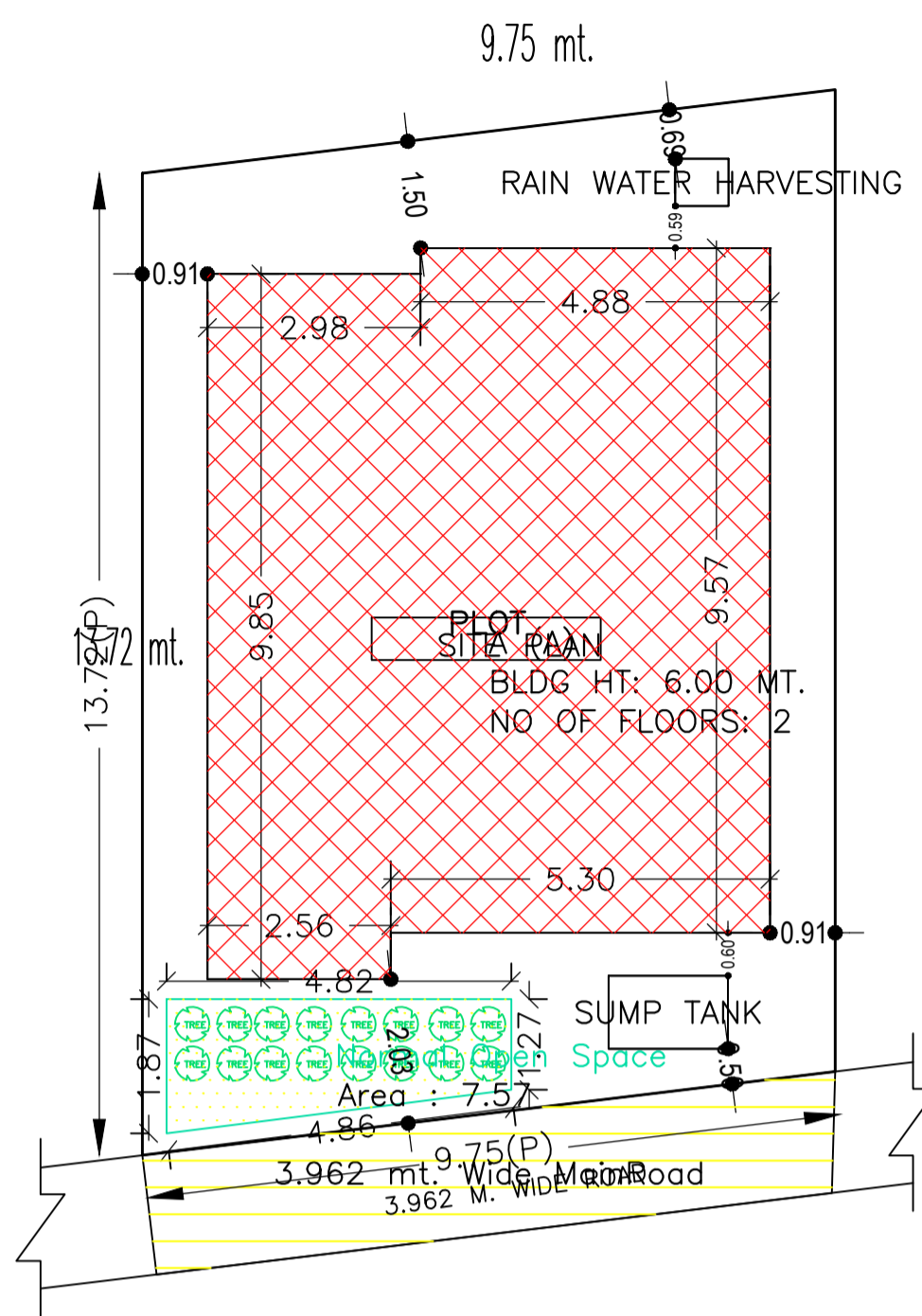
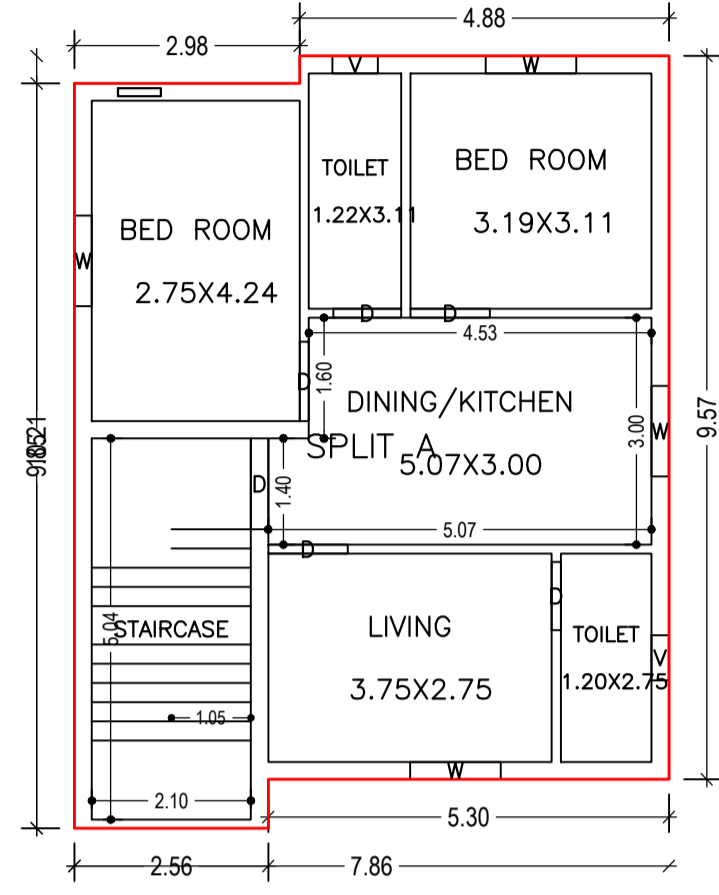

FIRST FLOOR PLAN (Proposed) (SCALE 1:100)

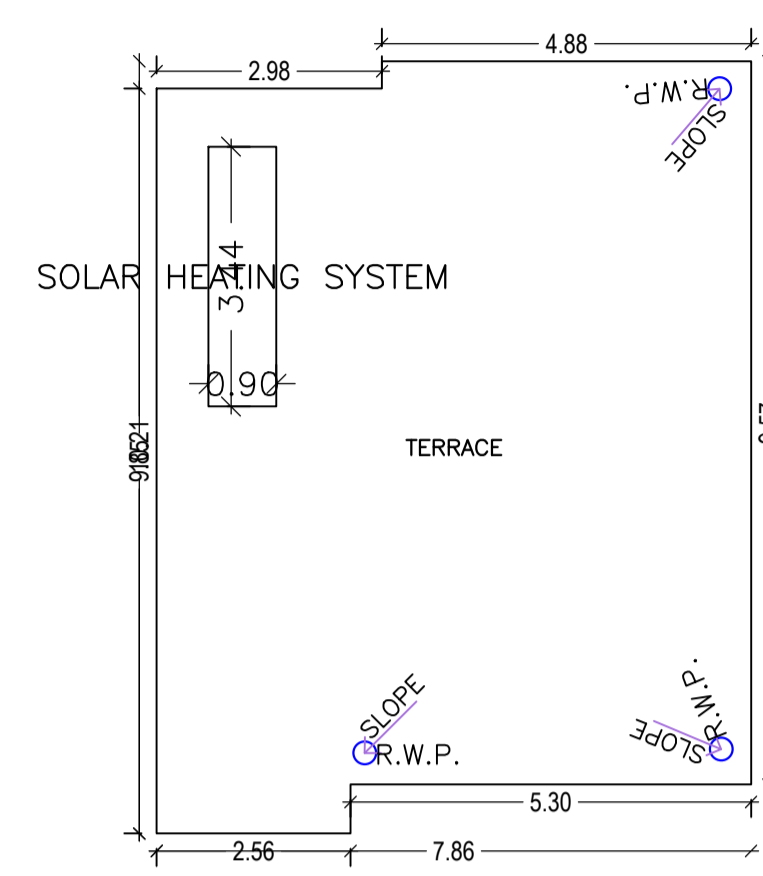

TERRACE FLOOR PLAN (SCALE 1:100)

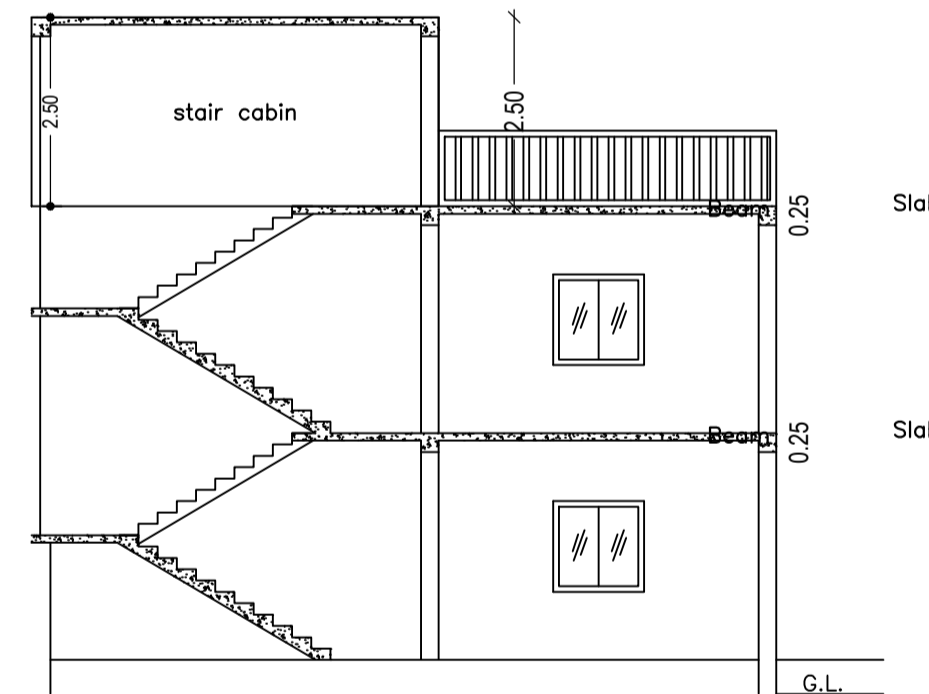

SECTION ON X-X

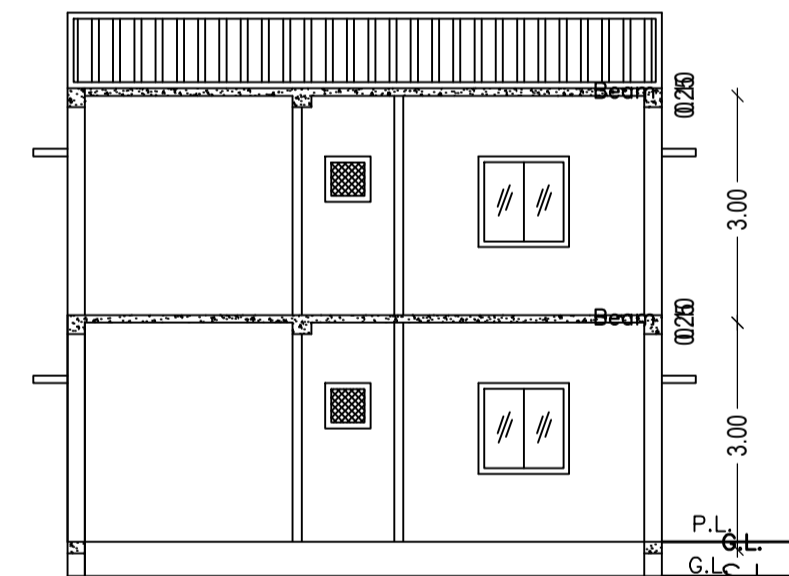

SECTION ON Y-Y

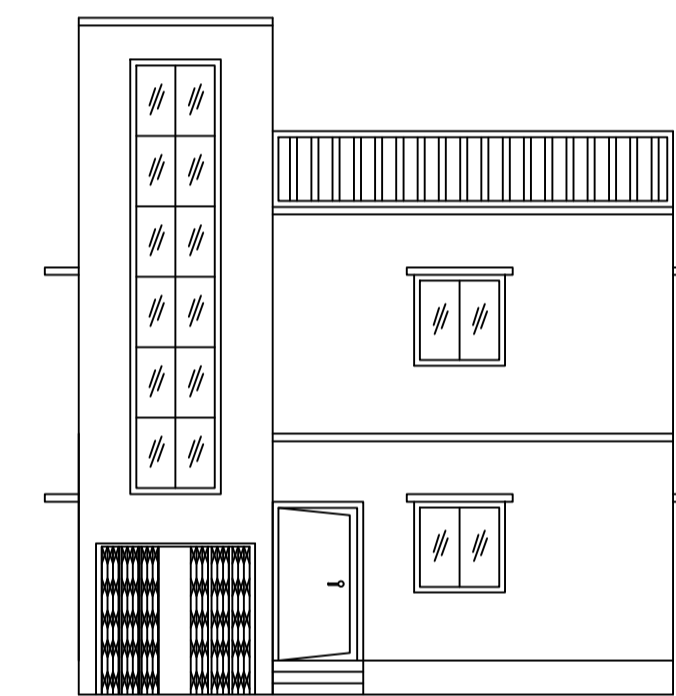

FRONT ELEVATION

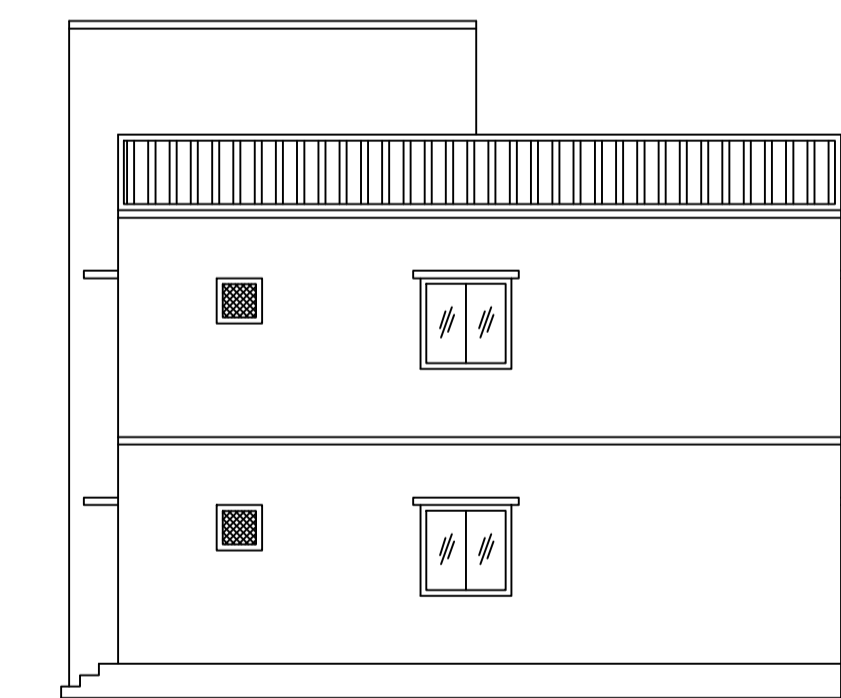

RIGHT SIDE ELEVATION

Building :A (A)

Floor Name	Total Built Up Area (Sq.mt.)	Proposed FAR Area (Sq.mt.)		Total Consumed Additional FAR Area (Sq.mt.)	Tnmt (No.)
		Resi.	Total FAR Area (Sq.mt.)		
Ground Floor	75.80	75.80	75.80	75.80	01
First Floor	75.80	75.80	75.80	75.80	00
Terrace Floor	0.00	0.00	0.00	0.00	00
Total :	151.60	151.60	151.60	151.60	01
Total Number of Same Buildings :	1				
Total :	151.60	151.60	151.60	151.60	01

SCHEDULE OF DOOR:

BUILDING NAME	NAME	LENGTH	HEIGHT	NOS
A (A)	D	0.90	2.10	04
A (A)	D	1.05	2.10	06
A (A)	D	1.20	2.10	03

SCHEDULE OF WINDOW/VENTILATION:

BUILDING NAME	NAME	LENGTH	HEIGHT	NOS
A (A)	V	0.60	1.20	04
A (A)	W	1.20	1.20	08

UnitBUA Table for Building :A (A)

FLOOR	Name	UnitBUA Type	UnitBUA Area	Carpet Area	No. of Rooms	No. of Tenement
GROUND FLOOR PLAN	SPLIT A	FLAT	151.60	151.49	6	1
FIRST FLOOR PLAN	SPLIT A	FLAT	0.00	0.00	6	0
Total:	-	-	151.60	151.49	12	1

AREA STATEMENT		VERSION NO. : 1.0.56
DHANBAD MUNICIPAL CORPORATION		VERSION DATE: 16/10/2020
PROJECT DETAIL:		
Region: JHARKHAND URBAN	Plot Use: Residential	
LOCAL BODIES	Plot SubUse: Bungalow/ Dwelling / Non Apartment	
District: DHANBAD	PlotNearby/ReligiousStructure: NA	
Authority: DHANBAD MUNICIPAL CORPORATION	Plot/SubPlot No: OLD-398, NEW-436	
Inward_No: DMC/BP/0090/W30/2021	North: Plot No. - PART OF THIS PLOT	
Application Type: General Proposal	South: Plot No. - PART OF THIS PLOT	
Project Type: Building Permission	East: Plot No. - PART OF THIS PLOT	
Nature of Development: New	West: Road Width - 4.14	
Location of Development Area: Old Area		
AREA DETAILS:		
AREA OF PLOT (Minimum)	(A)	132.82
NET AREA OF PLOT(Gross Plot Area - Deduction from Gross Plot area)	(A-Deductions)	132.82
Deduction for Balance Plot Area(from Gross Plot Area)		
Common Plot		7.57
Total		7.57
BALANCE AREA OF PLOT(Net Plot Area - Recreational/Amenity space)	(A-Deductions)	125.25
PLOT AREA FOR COVERAGE(Net Plot Area)	(A-Deductions)	132.82
Plot Area for FAR (Net Plot Area + RoadWidening Area)	(A-Deductions)	132.82
COVERAGE CHECK		
Permissible Coverage area (70.00 %)		92.97
Proposed Coverage Area (57.07 %)		75.80
Total Prop. Coverage Area (57.07 %)		75.80
Balance coverage area (12.93 %)		17.17
FAR CHECK		
Perm. FAR Area (1.50)		199.23
Total Perm. FAR area		199.23
Residential FAR		151.61
Proposed FAR Area		151.61
Total Proposed FAR Area		151.61
Consumed FAR (Factor)		1.14
Balance FAR Area		47.62
BUILT UP AREA CHECK		
Total Proposed BuiltUp Area		151.60
ARCHITECT (Regd)		SANJEEV KUMAR RAY
ENGINEER (Regd)		
SUPERVISOR (Regd)		
OWNER (Regd)		AJAY KUMAR MAHTO
DEVELOPMENT AUTHORITY		LOCAL BODY

COLOR INDEX	
PLOT BOUNDARY	Black
ABUTTING ROAD	Green
PROPOSED CONSTRUCTION	Red
COMMON PLOT	Yellow
ROAD WIDENING AREA	Blue
EXISTING (To be retained)	Light Blue
EXISTING (To be demolished)	Dark Blue

Buildingwise Floor FAR Details

Floor Name	Building Name A (A)		Total	
	Proposed Built Up Area (Sq.mt.)	Proposed FAR Area (Sq.mt.)	Total Proposed Built Up Area (Sq.mt.)	Total FAR Area (Sq.mt.)
Ground Floor	75.80	75.80	75.80	75.80
First Floor	75.80	75.80	75.80	75.80
Terrace Floor	0.00	0.00	0.00	0.00
Total :	151.60	151.60	151.60	151.60

Building USE/SUBUSE Details

Building Name	Building Use	Building SubUse	Building Structure
A (A)	Residential	Residential Bldg/Apartment	Non-Highrise

FAR & Tenement Details (Table 4c-1)

Building	No. of Same Bldg	Total Built Up Area (Sq.mt.)	Proposed FAR Area (Sq.mt.)		Total Consumed Additional FAR Area (Sq.mt.)	Tnmt (No.)
			Resi.	Total FAR Area (Sq.mt.)		
A (A)	1	151.60	151.60	151.60	151.60	01
Grand Total :	1	151.60	151.60	151.60	151.60	01

LTP NAME AND SIGNATURE	STRUCTURAL ENG'S NAME AND SIGNATURE	BUILDER NAME AND SIGNATURE	DIGITAL SIGNATURE
SANJEEV KUMAR RAY DMC/ENG/0001/2019			

Proposal Basic Information	
Proposal File No.	DMC/BP/0090/W30/2021
Owner Name	AJAY KUMAR MAHTO
Khata No	OLD-122,NEW-16
Plot No	OLD-398, NEW-436
Village Name	Patrakulhi
Use	Residential
SubUse	Bungalow/ Dwelling / Non Apartment

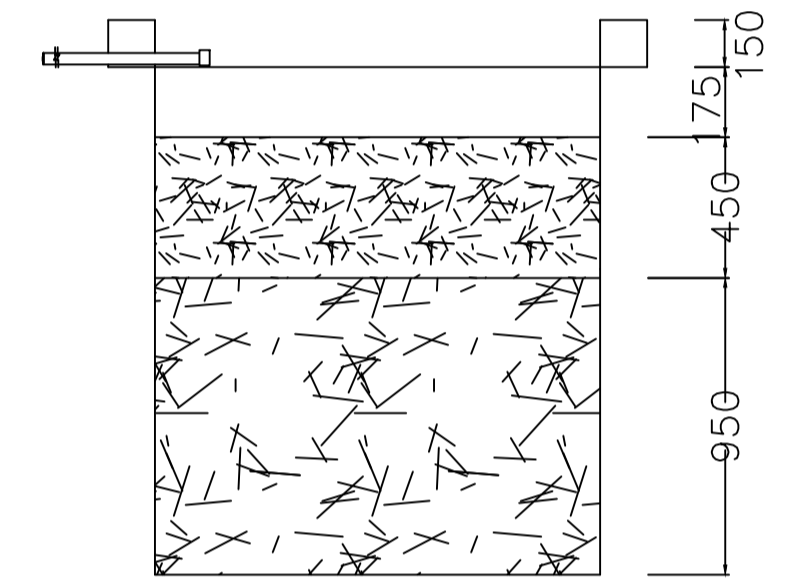
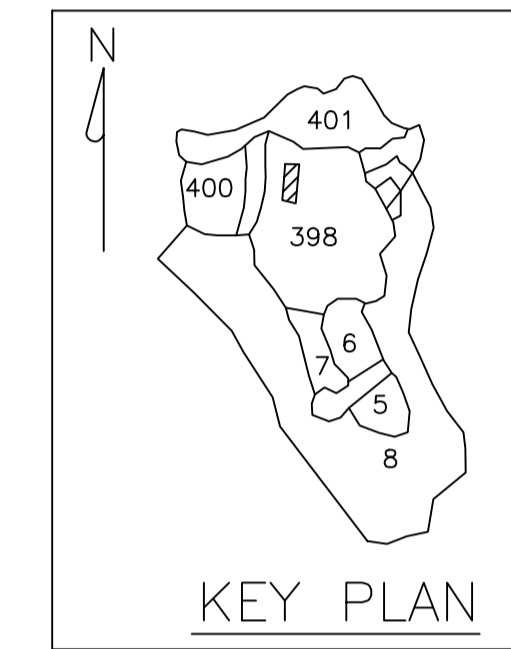
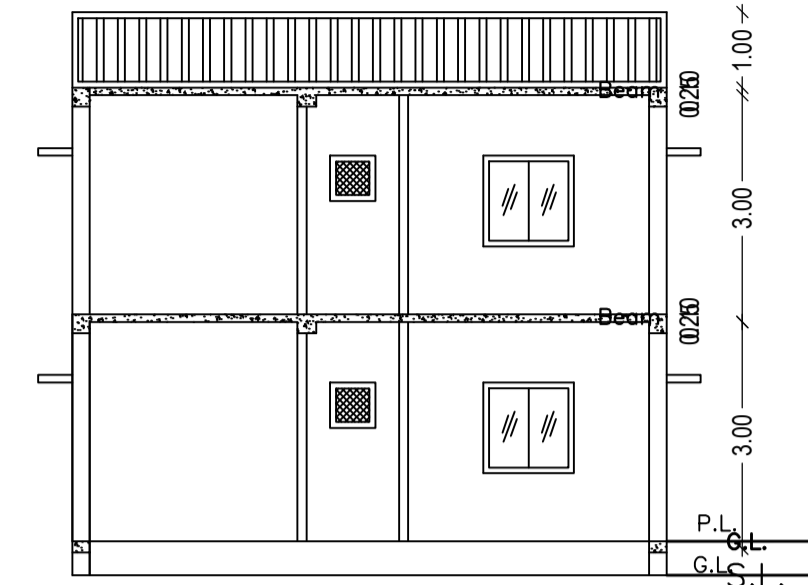
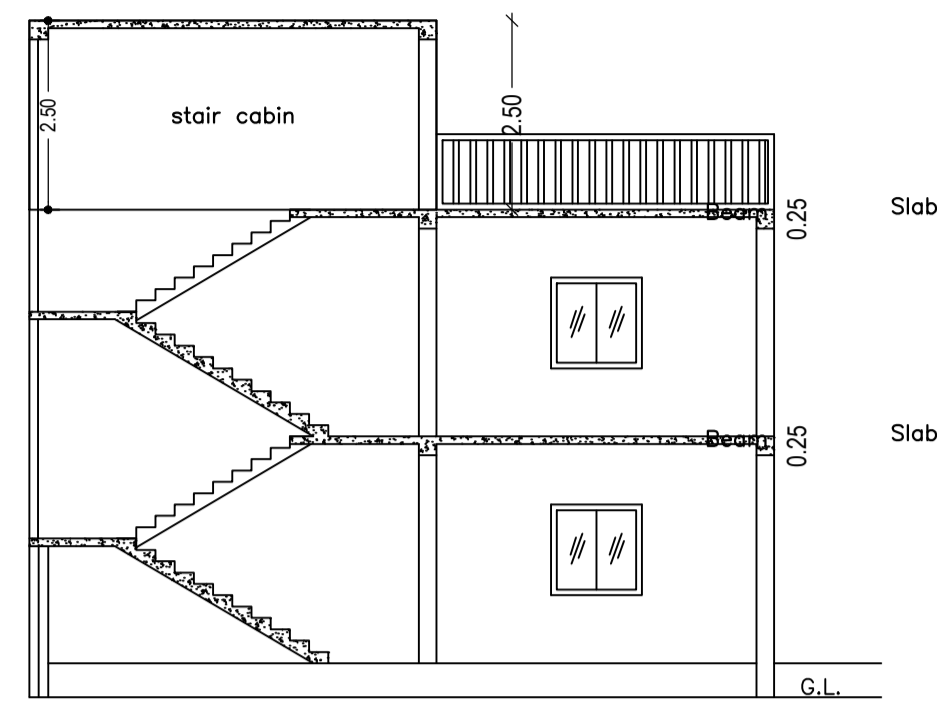
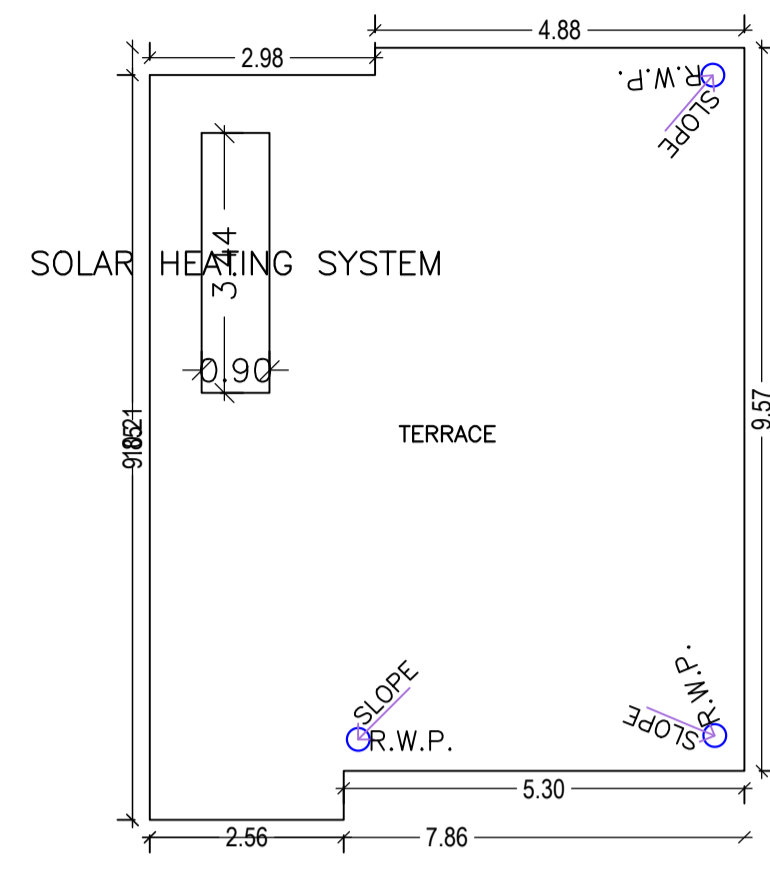
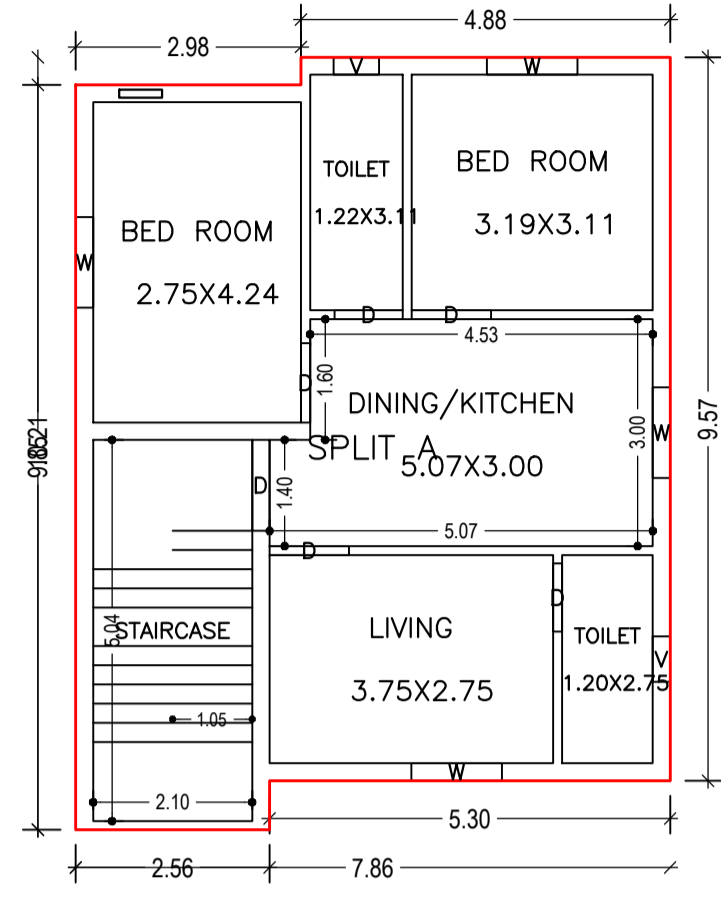
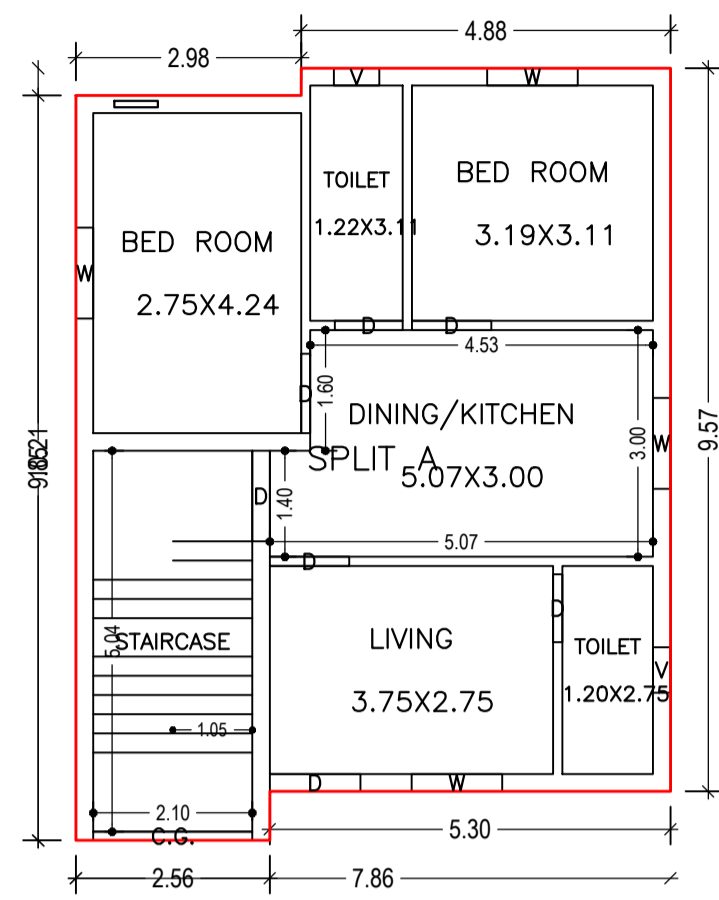

GROUND FLOOR PLAN (Proposed) (SCALE 1:100)

FIRST FLOOR PLAN (Proposed) (SCALE 1:100)

TERRACE FLOOR PLAN (SCALE 1:100)

SECTION ON X-X

SECTION ON Y-Y

KEY PLAN

SECTION AT Y-Y

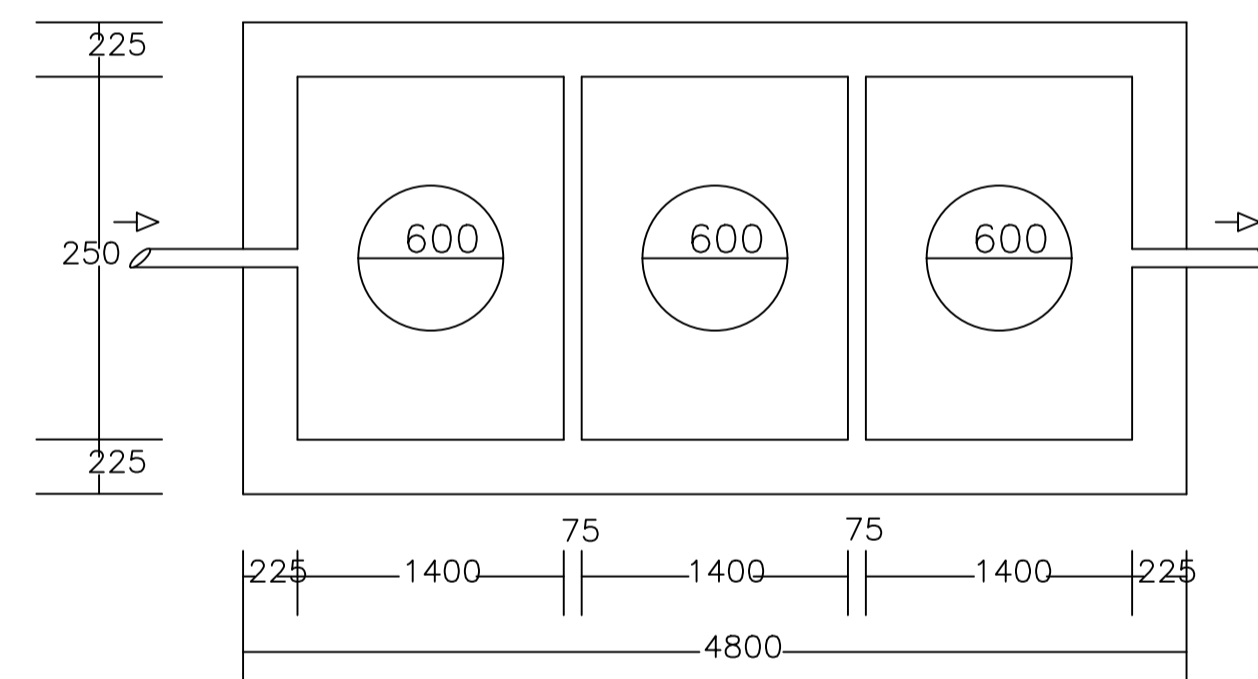
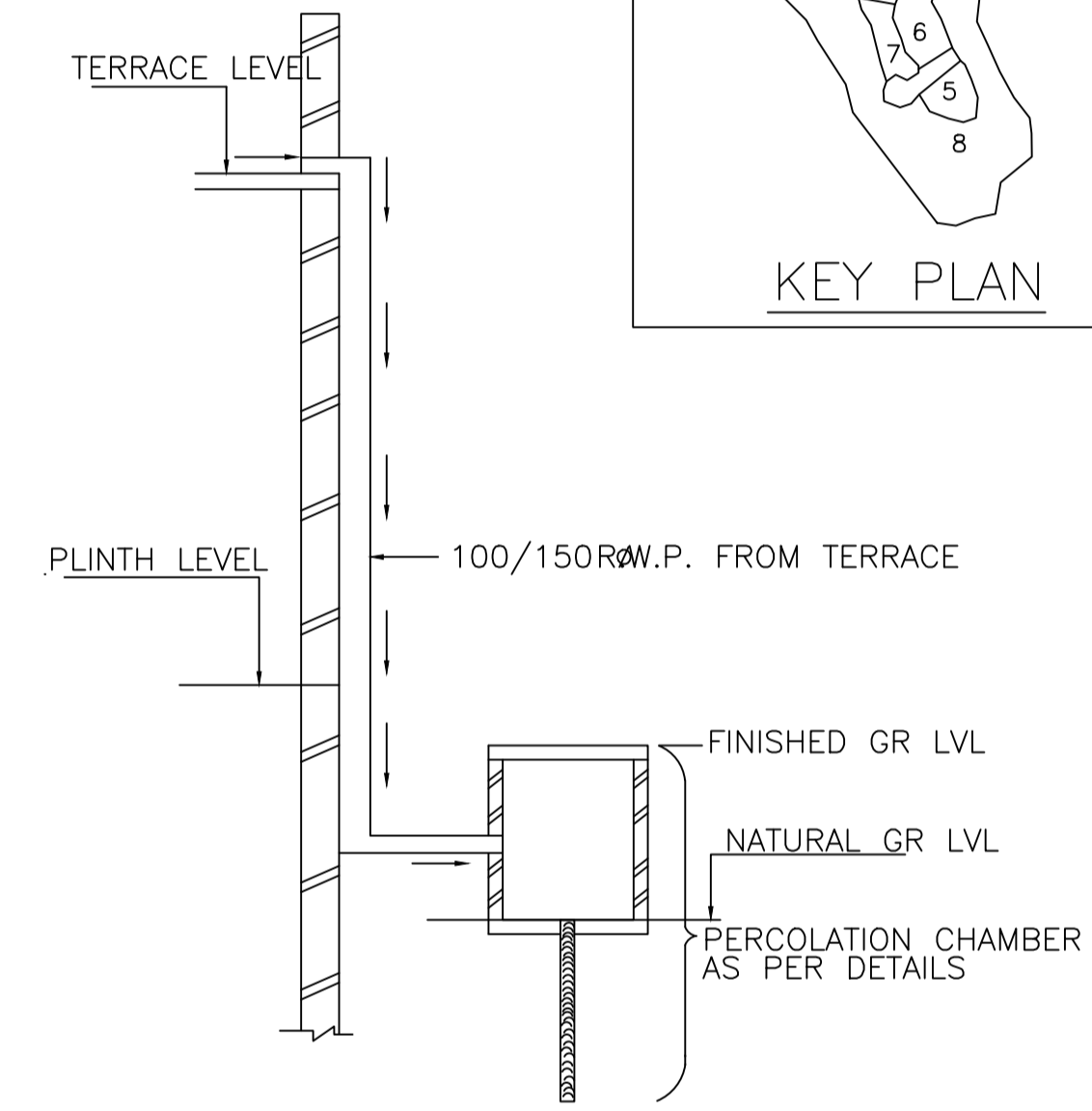
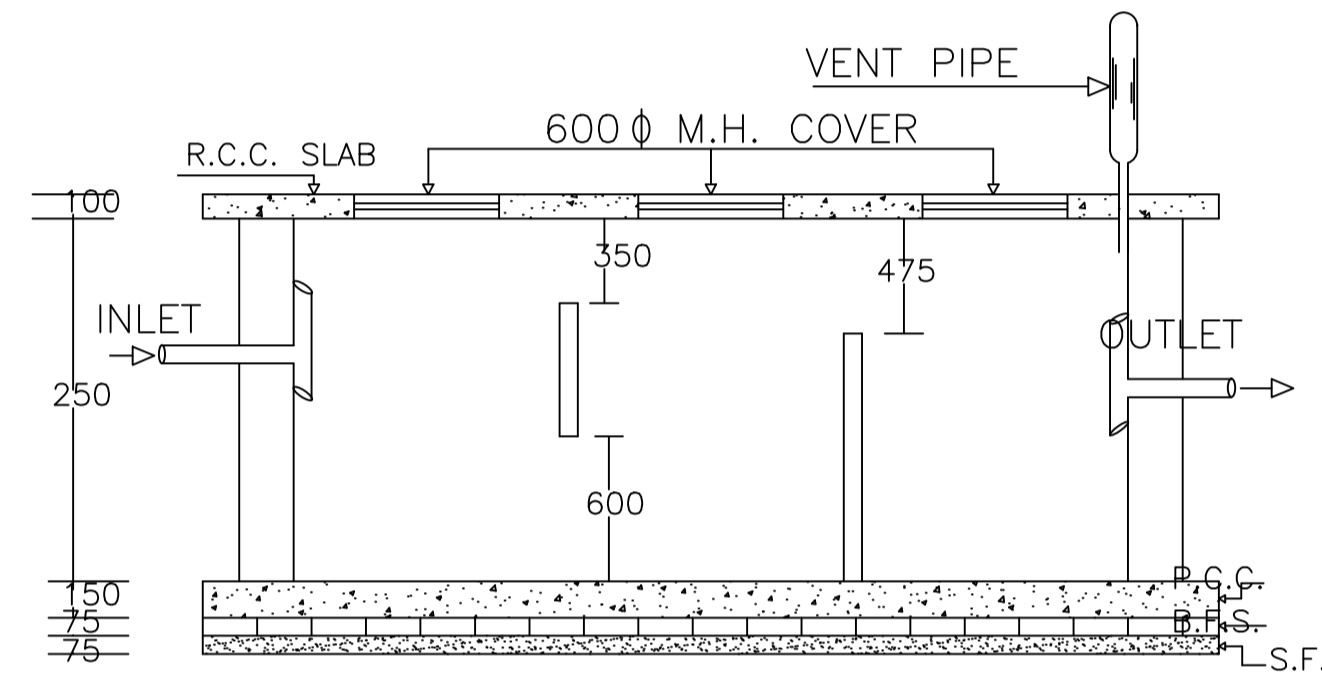
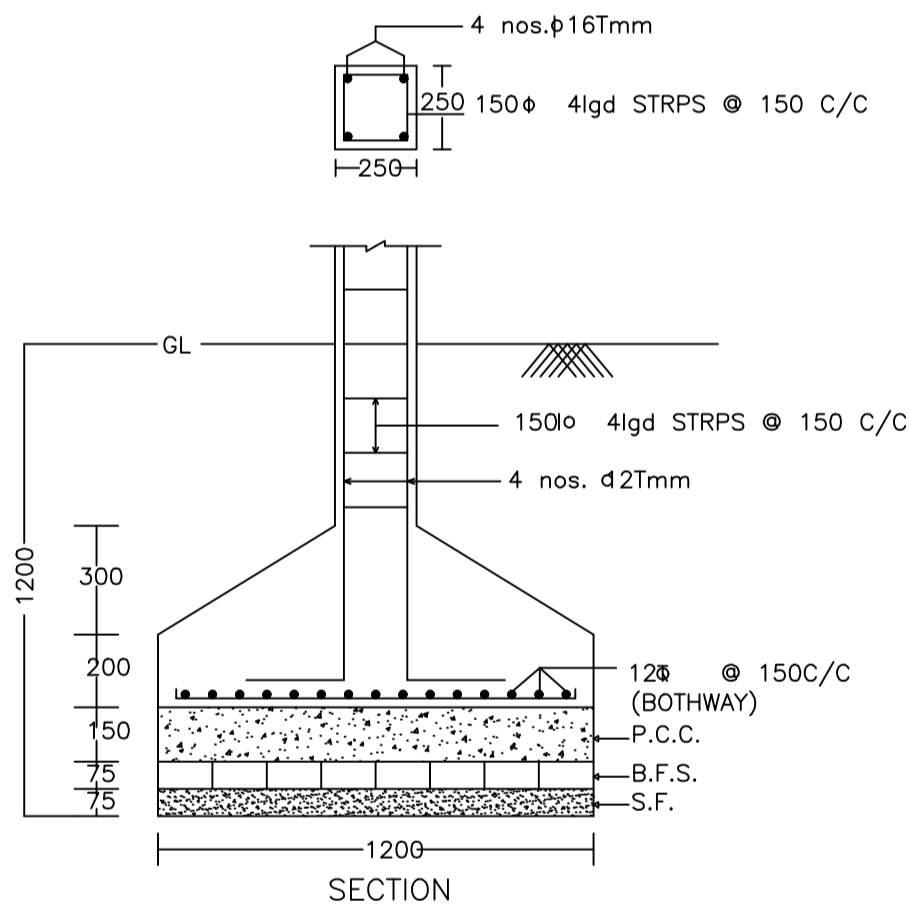
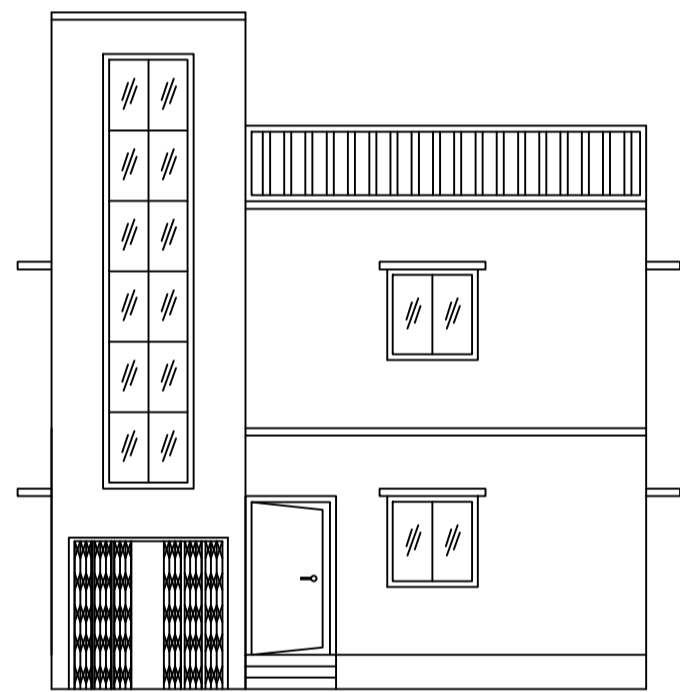

PLAN OF RECHARGE WELL WATER HARVESTING

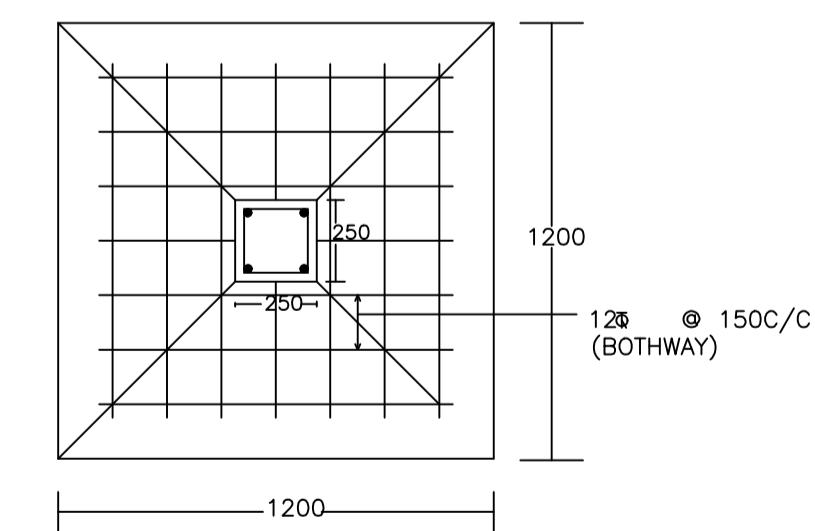
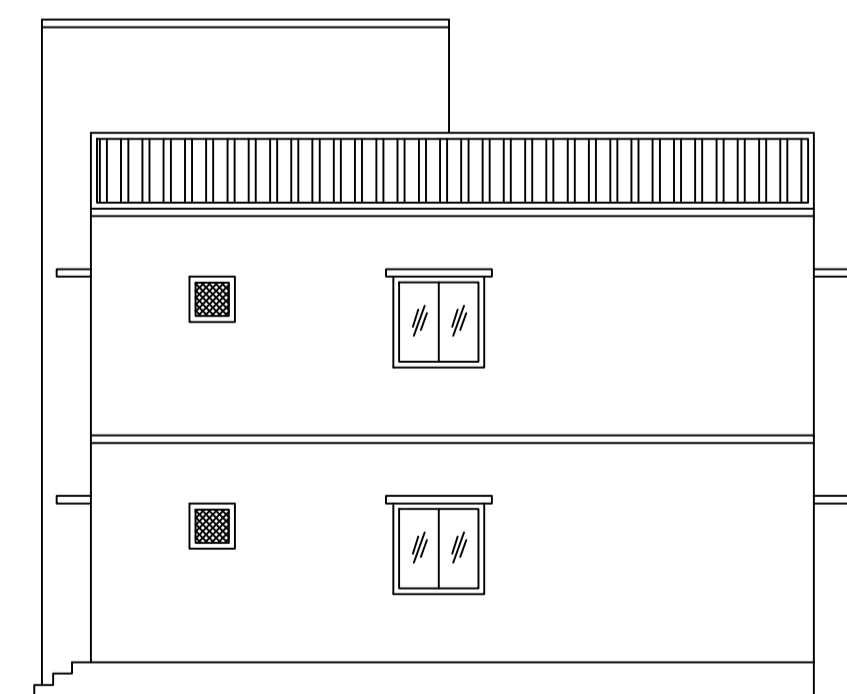

DETAIL OF COLUMNS

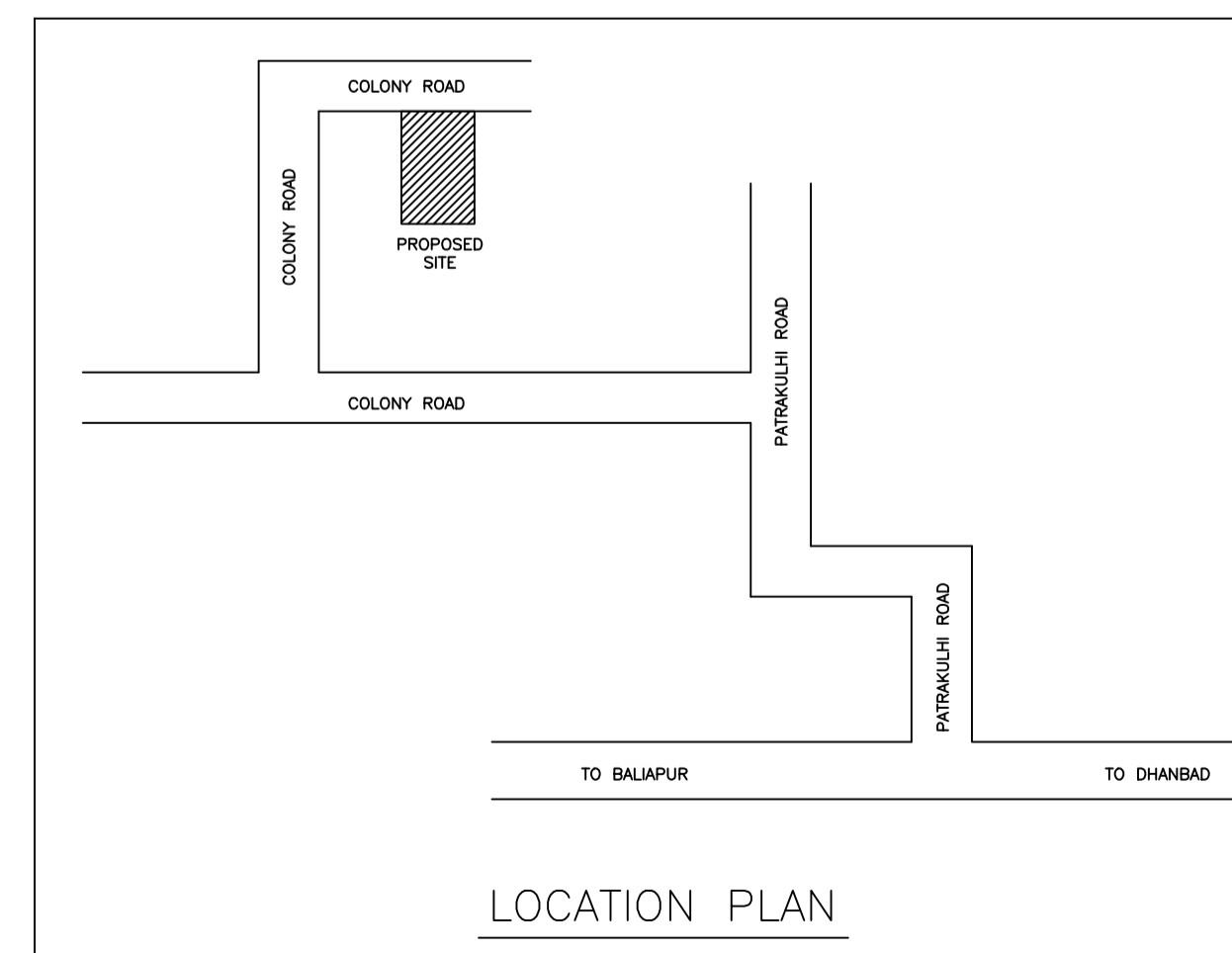

LTP NAME AND SIGNATURE	STRUCTURAL ENG'S NAME AND SIGNATURE	BUILDER NAME AND SIGNATURE	DIGITAL SIGNATURE
SANJEEV KUMAR RAY DMC/ENG/0001/2019			