

AREA STATEMENT		VERSION NO.: 1.0.55
DHANBAD MUNICIPAL CORPORATION		VERSION DATE: 16/10/2020
PROJECT DETAIL:		
Region: JHARKHAND URBAN LOCAL BODIES	Plot Use: Residential	
District: DHANBAD	Plot SubUse: Bungalow/ Dwelling / Non Apartment	
Authority: DHANBAD MUNICIPAL CORPORATION	PlotNearbyReligiousStructure: NA	
Inward No: DMC/BP/0075/W23/2021	Plot/SubPlot No: NEW - 414 , OLD - 556	
Application Type: General Proposal	North: Plot No. - PART OF THIS PLOT	
Project Type: Building Permission	South: Plot No. - PART OF THIS PLOT	
Nature of Development: New	East: Road Width - 3.65 M WIDE ROAD	
Location of Development Area: Old Area	West: Plot No. - PART OF THIS PLOT	
AREA DETAILS:		SQ.MT.
AREA OF PLOT (Minimum)	(A)	265.97
NET AREA OF PLOT (Gross Plot Area - Deduction from Gross Plot area)	(A-Deductions)	265.97
Deduction for Balance Plot Area (from Gross Plot Area)		
Common Plot		14.30
Total		14.30
BALANCE AREA OF PLOT (Net Plot Area - Recreational/Amenity space)	(A-Deductions)	251.66
PLOT AREA FOR COVERAGE (Net Plot Area)	(A-Deductions)	265.97
Plot Area for FAR (Net Plot Area + Road Widening Area)	(A-Deductions)	265.97
COVERAGE CHECK		
Permissible Coverage area (60.00 %)		159.58
Proposed Coverage Area (56.88 %)		151.29
Total Prop. Coverage Area (56.88 %)		151.29
Balance coverage area (3.12 %)		8.29
FAR CHECK		
Perm. FAR Area (1.50)		398.96
Total Perm. FAR area		398.96
Residential FAR		302.57
Proposed FAR Area		302.57
Total Proposed FAR Area		302.57
Consumed FAR (Factor)		1.14
Balance FAR Area		96.39
BUILT UP AREA CHECK		
Total Proposed BuiltUp Area		302.58
ARCHITECT (Regd)	ABHISHEK KUMAR	
ENGINEER (Regd)		
SUPERVISOR (Regd)		
OWNER (Regd)	1, SMT PINKI SINGH 2, SMT SUNITA SINGH	
DEVELOPMENT AUTHORITY		LOCAL BODY

COLOR INDEX	
PLOT BOUNDARY	Black
ABUTTING ROAD	Red
PROPOSED CONSTRUCTION	Green
COMMON PLOT	Yellow
ROAD WIDENING AREA	Blue
EXISTING (To be retained)	Light Blue
EXISTING (To be demolished)	Orange

SCHEDULE OF DOOR:

BUILDING NAME	NAME	LENGTH	HEIGHT	NOS
AA (BB)	D	0.64	2.10	02
AA (BB)	D	0.74	2.10	02
AA (BB)	D	0.76	2.10	04
AA (BB)	D	0.91	2.10	08
AA (BB)	D	1.05	2.10	04
AA (BB)	D	1.07	2.10	02
AA (BB)	D	1.08	2.10	02
AA (BB)	D	1.52	2.10	02
AA (BB)	D	1.63	2.10	02

SCHEDULE OF WINDOW/VENTILATION:

BUILDING NAME	NAME	LENGTH	HEIGHT	NOS
AA (BB)	W	0.61	1.20	06
AA (BB)	W	0.81	1.20	10
AA (BB)	W	1.22	1.20	14
AA (BB)	W	1.43	1.20	02
AA (BB)	W	1.52	1.20	02

Building :AA (BB)

Floor Name	Total Built Up Area (Sq.mt.)	Proposed FAR Area (Sq.mt.) Res.	Total FAR Area (Sq.mt.)	Total Consumed Additional FAR Area (Sq.mt.)	Tnmt (No.)
Ground Floor	151.29	151.29	151.29	151.29	01
First Floor	151.29	151.29	151.29	151.29	00
Terrace Floor	0.00	0.00	0.00	0.00	00
Total :	302.58	302.58	302.58	302.58	01
Total Number of Same Buildings :	1				
Total :	302.58	302.58	302.58	302.58	01

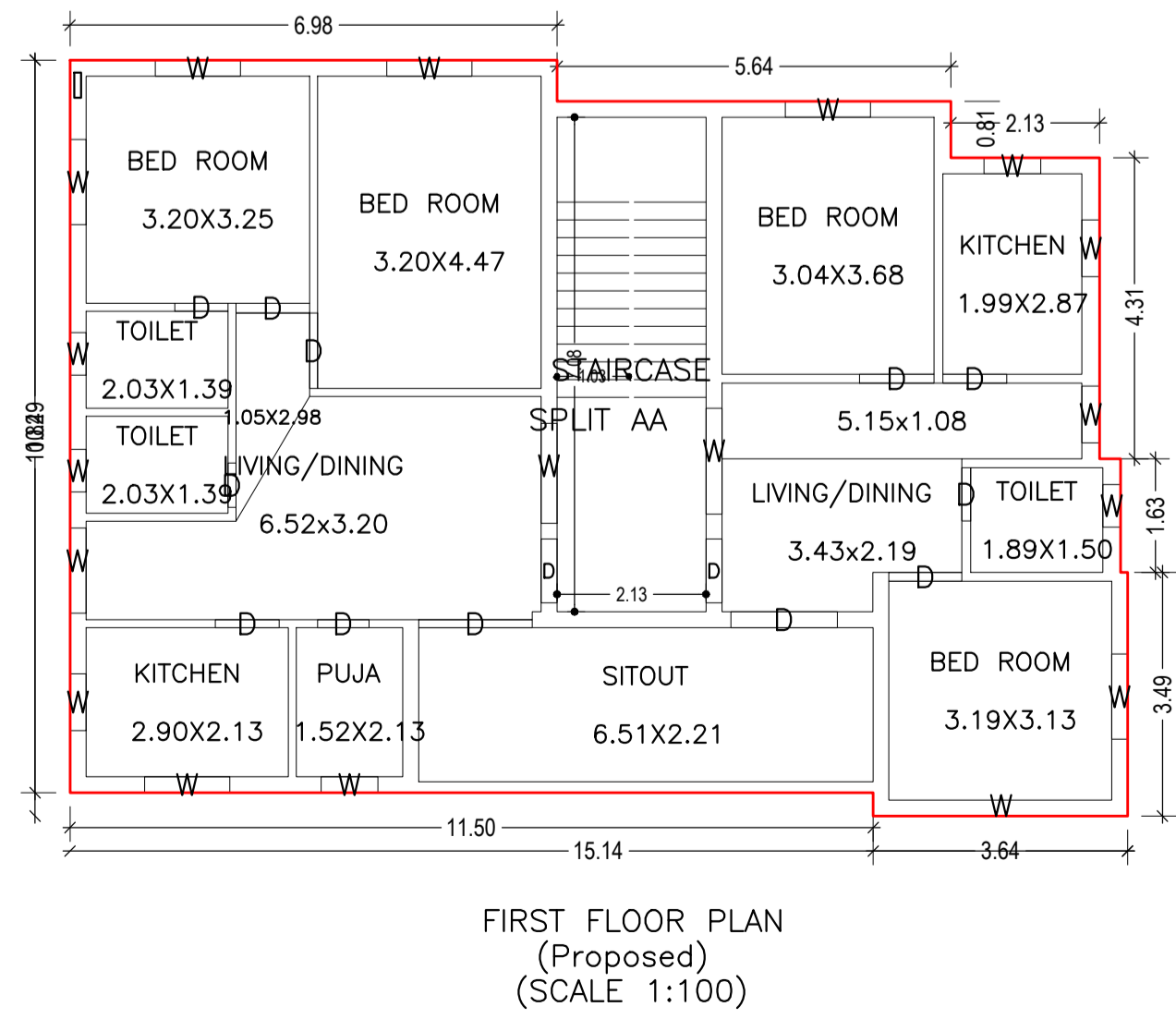
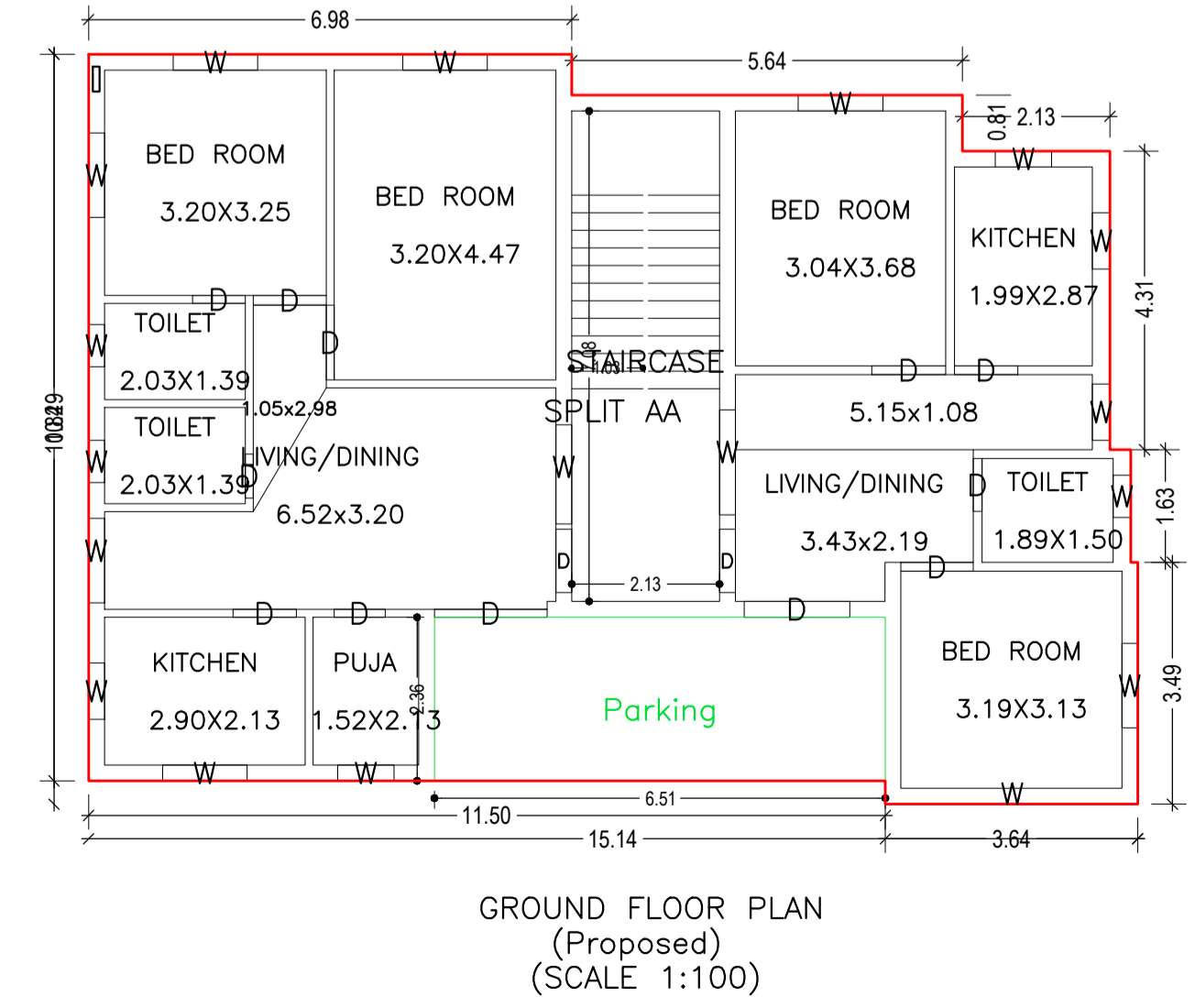

Buildingwise Floor FAR Details

Floor Name	Building Name AA (BB)		Total	
	Proposed Built Up Area (Sq.mt.)	Proposed FAR Area (Sq.mt.)	Total Proposed Built Up Area (Sq.mt.)	Total FAR Area (Sq.mt.)
Ground Floor	151.29	151.29	151.29	151.29
First Floor	151.29	151.29	151.29	151.29
Terrace Floor	0.00	0.00	0.00	0.00
Total :	302.58	302.58	302.58	302.58

Building USE/SUBUSE Details

Building Name	Building Use	Building SubUse	Building Structure
AA (BB)	Residential	Bungalow/ Dwelling / Non Apartment	Non-Highrise

FAR & Tenement Details (Table 4c-1)

Building	No. of Same Bldg	Total Built Up Area (Sq.mt.)	Proposed FAR Area (Sq.mt.) Res.	Total FAR Area (Sq.mt.)	Total Consumed Additional FAR Area (Sq.mt.)	Tnmt (No.)
AA (BB)	1	302.58	302.58	302.58	302.58	01
Grand Total :	1	302.58	302.58	302.58	302.58	01

UnitBUA Table for Building :AA (BB)

FLOOR	Name	UnitBUA Type	UnitBUA Area	Carpet Area	No. of Rooms	No. of Tenement
GROUND FLOOR	SPLIT AA	FLAT	302.57	302.50	12	1
FIRST FLOOR	SPLIT AA	FLAT	0.00	0.00	13	0
Total:	-	-	302.57	302.50	25	1

LTP NAME AND SIGNATURE	STRUCTURAL ENG'S NAME AND SIGNATURE	BUILDER NAME AND SIGNATURE	DIGITAL SIGNATURE
ABHISHEK KUMAR DMC/DFTM/0013/2020			

Proposal Basic Information	
Proposal File No.	DMC/BP/0075/W23/2021
Owner Name	1, SMT PINKI SINGH 2, SMT SUNITA SINGH
Khata No	NEW - 17 , OLD - 04
Plot No	NEW - 414 , OLD - 556
Village Name	Sabalpur
Use	Residential
SubUse	Bungalow/ Dwelling / Non Apartment

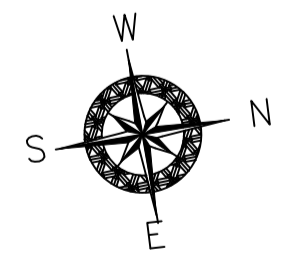
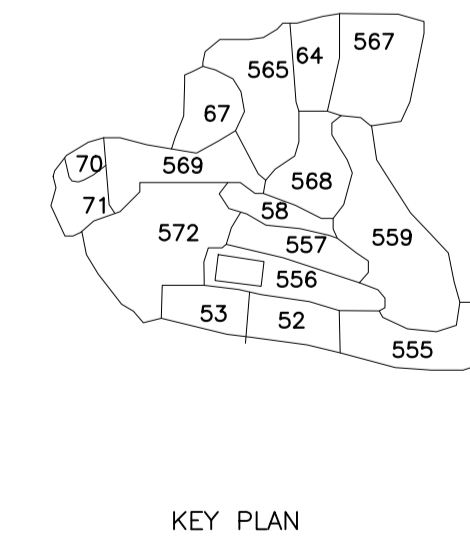
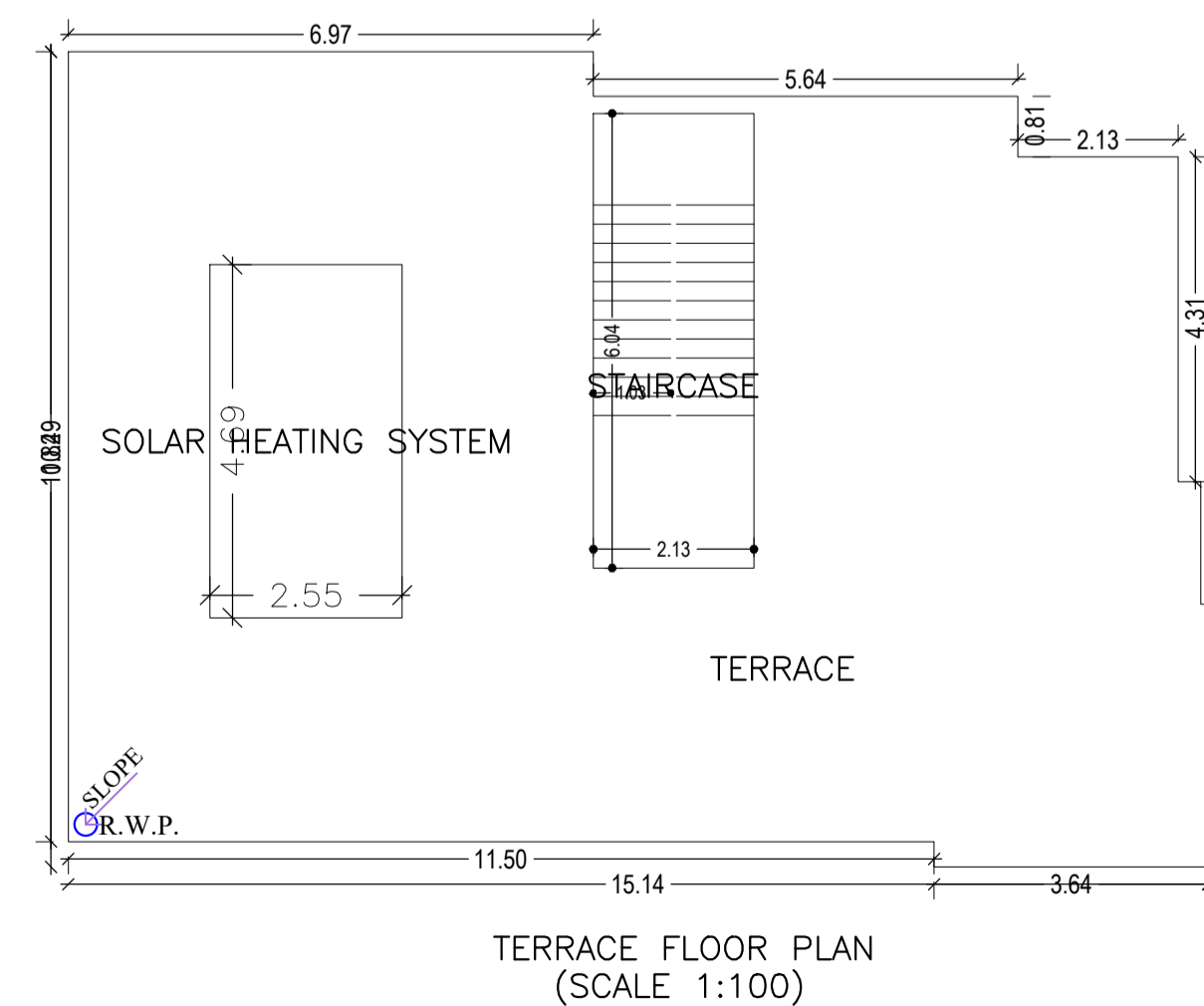
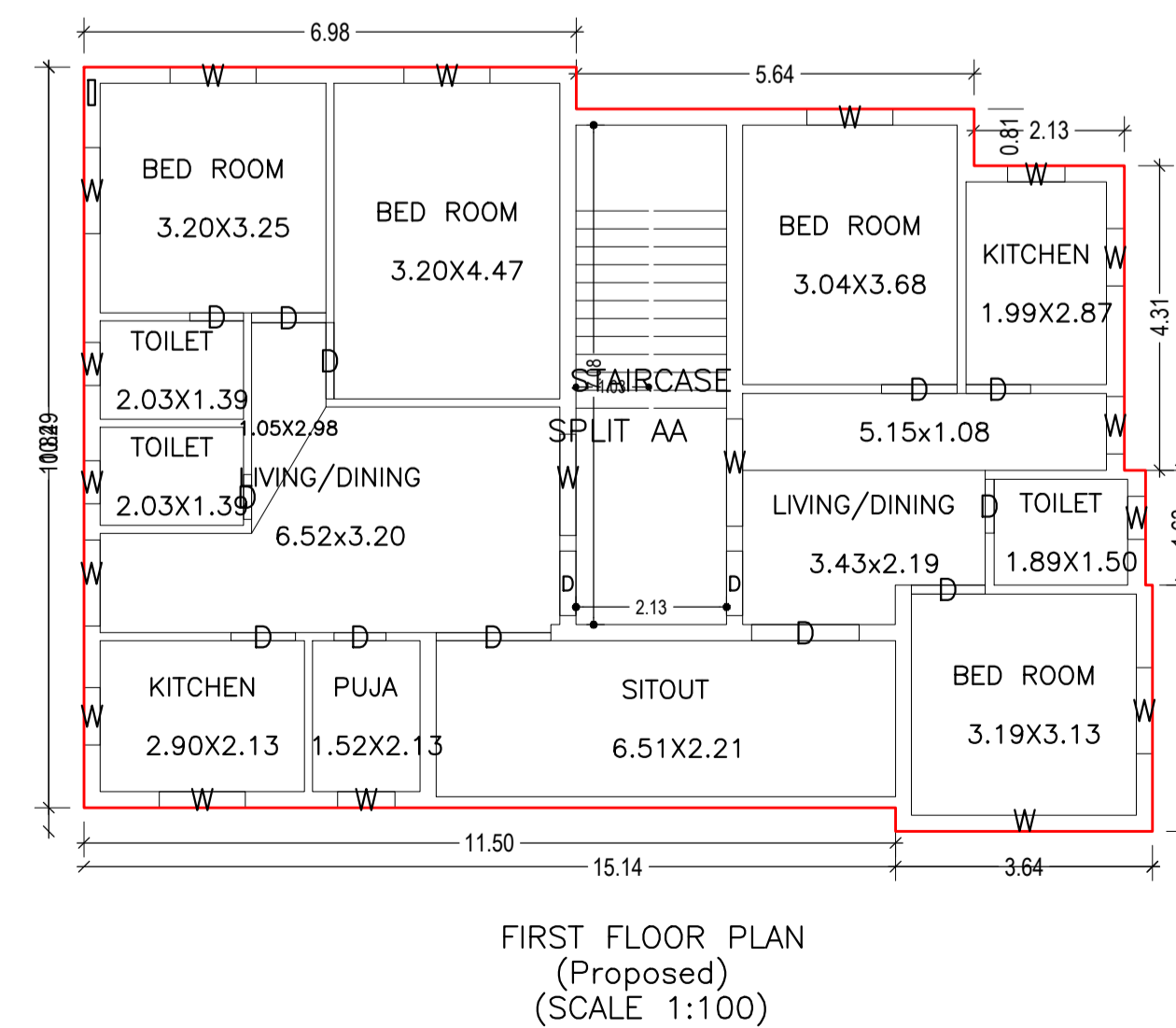
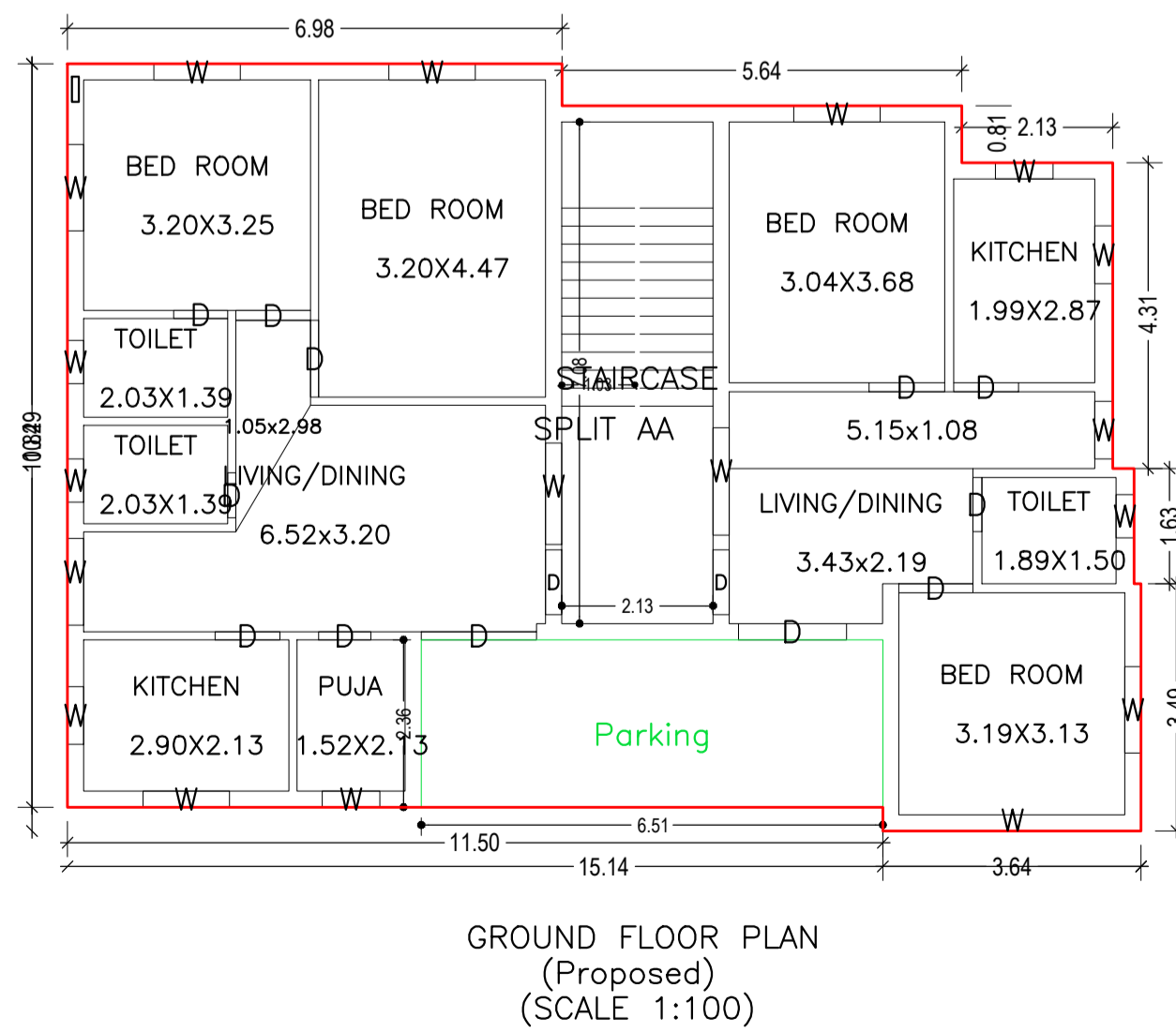
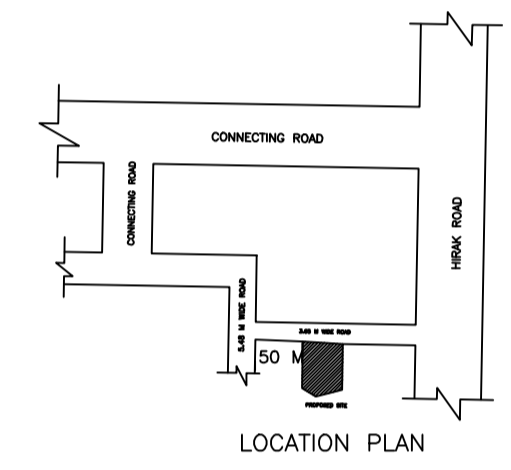
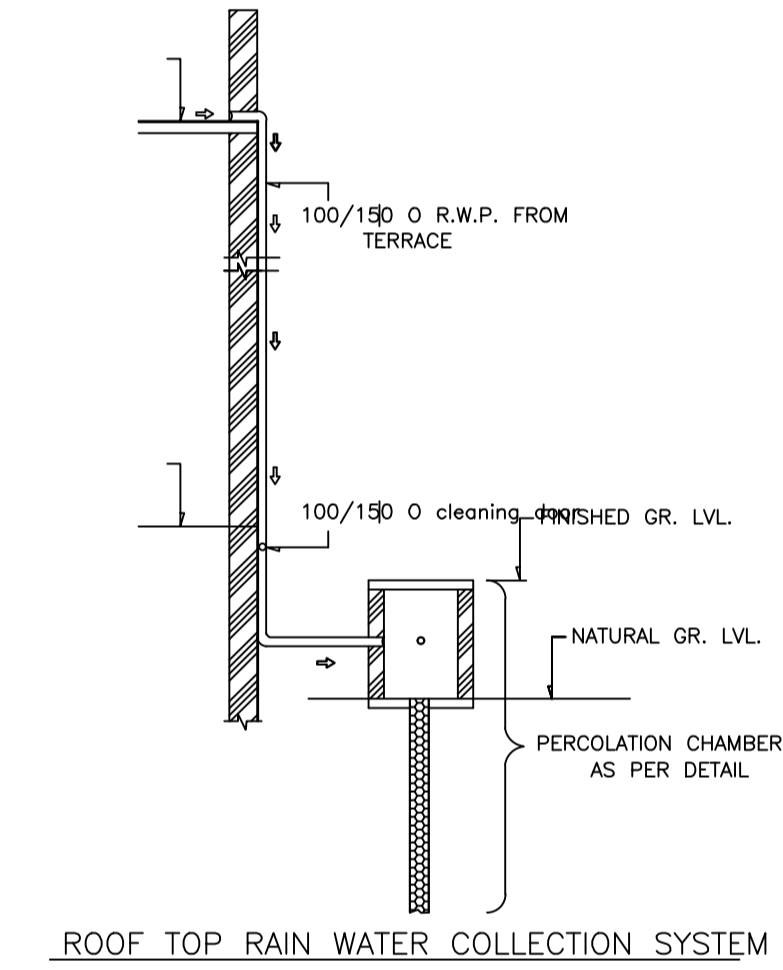
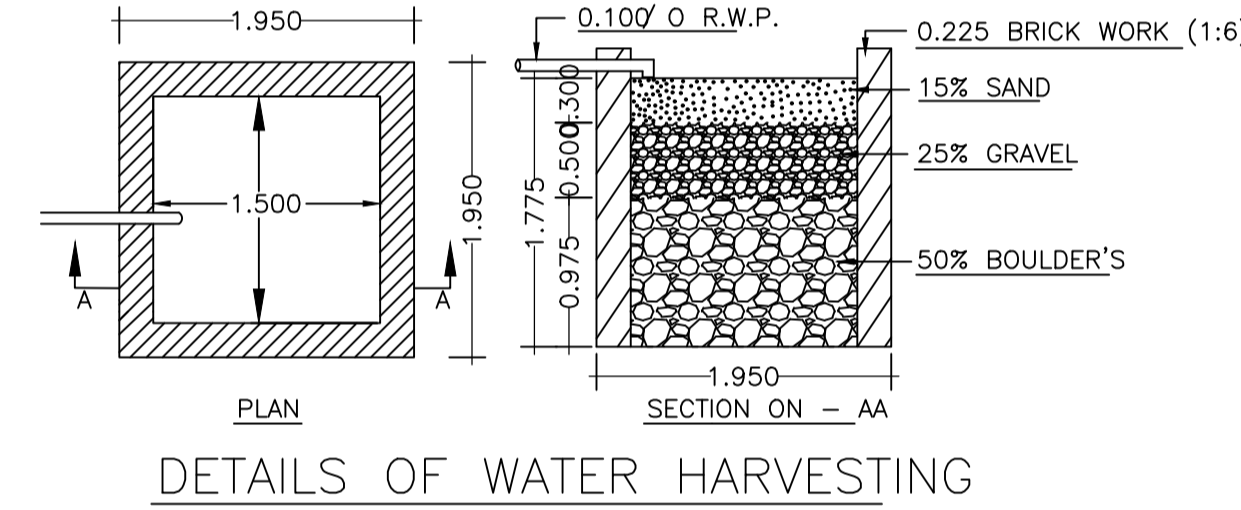
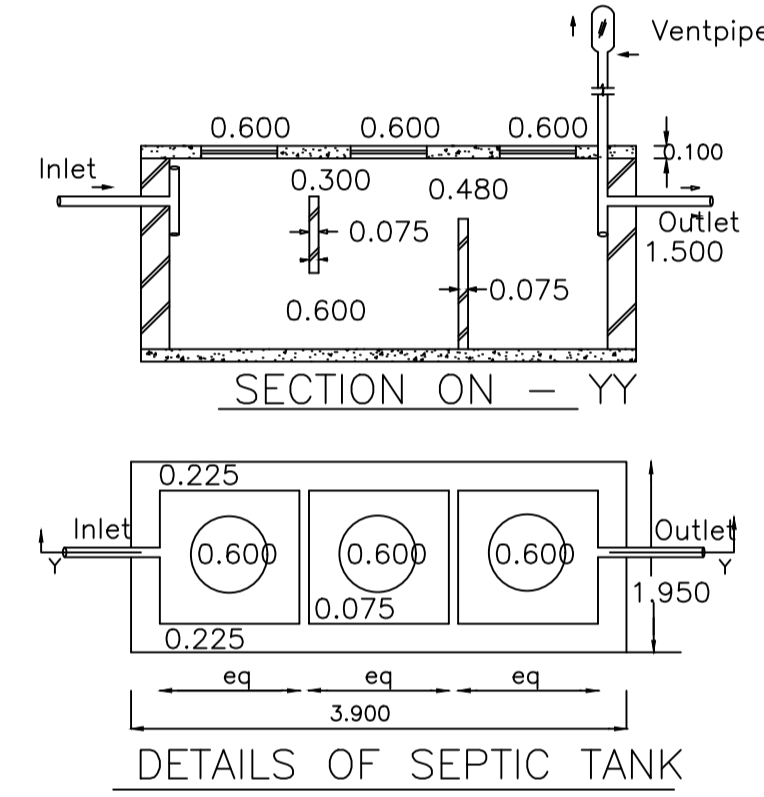
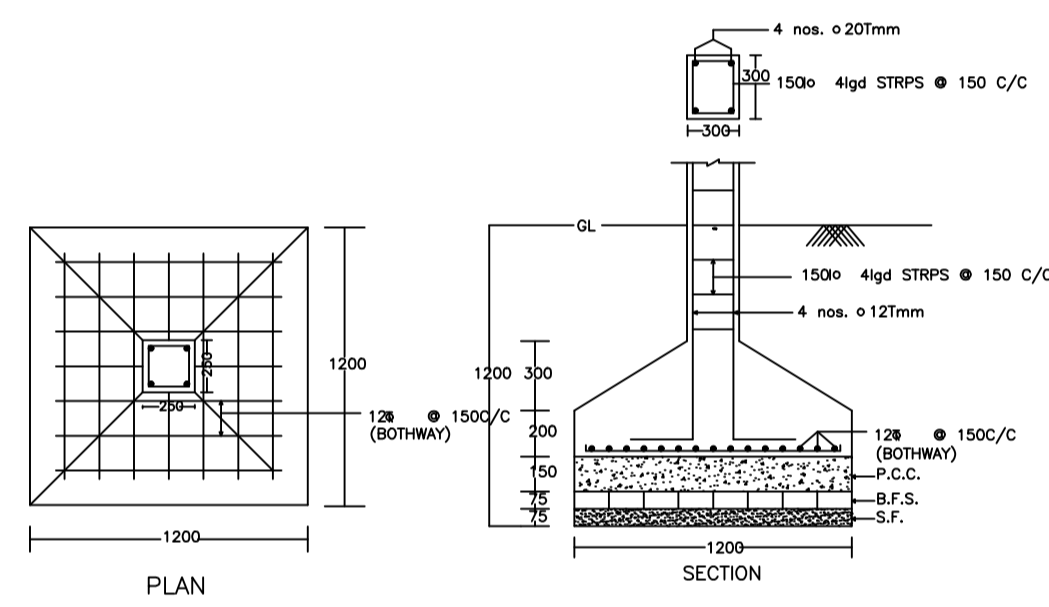
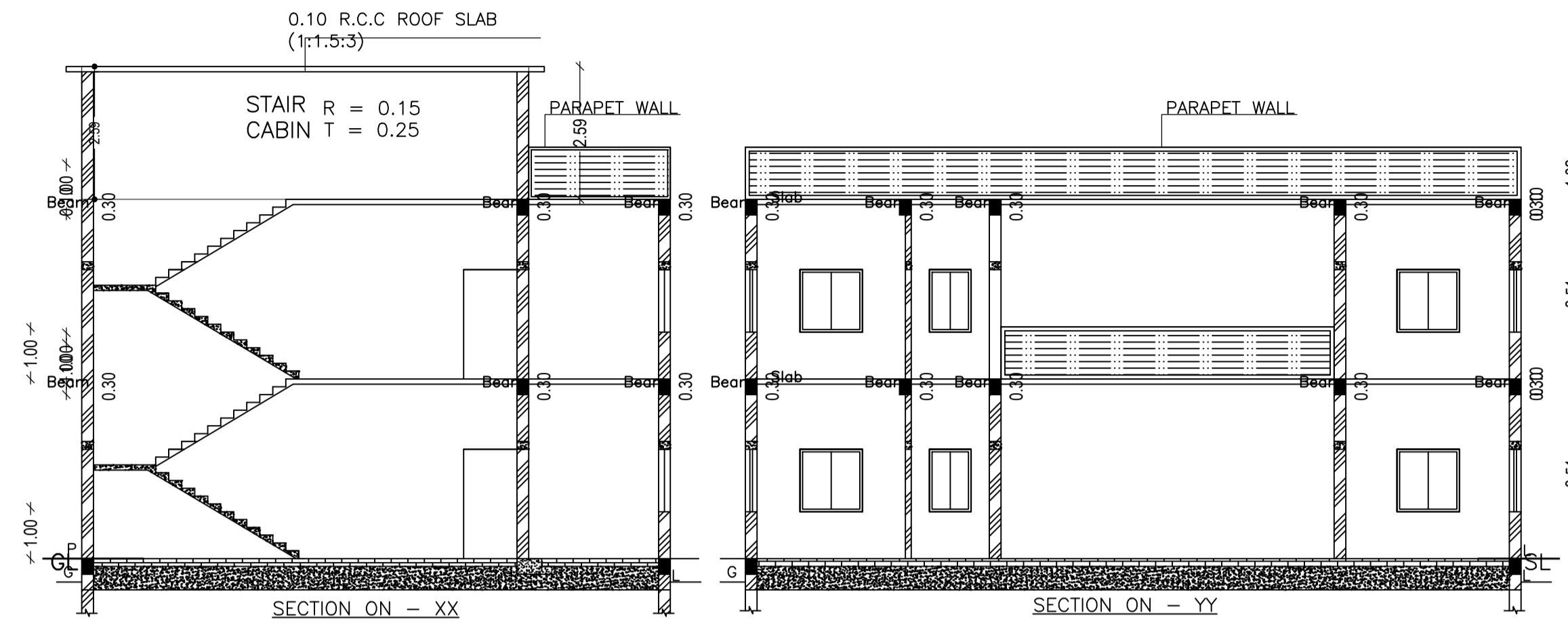
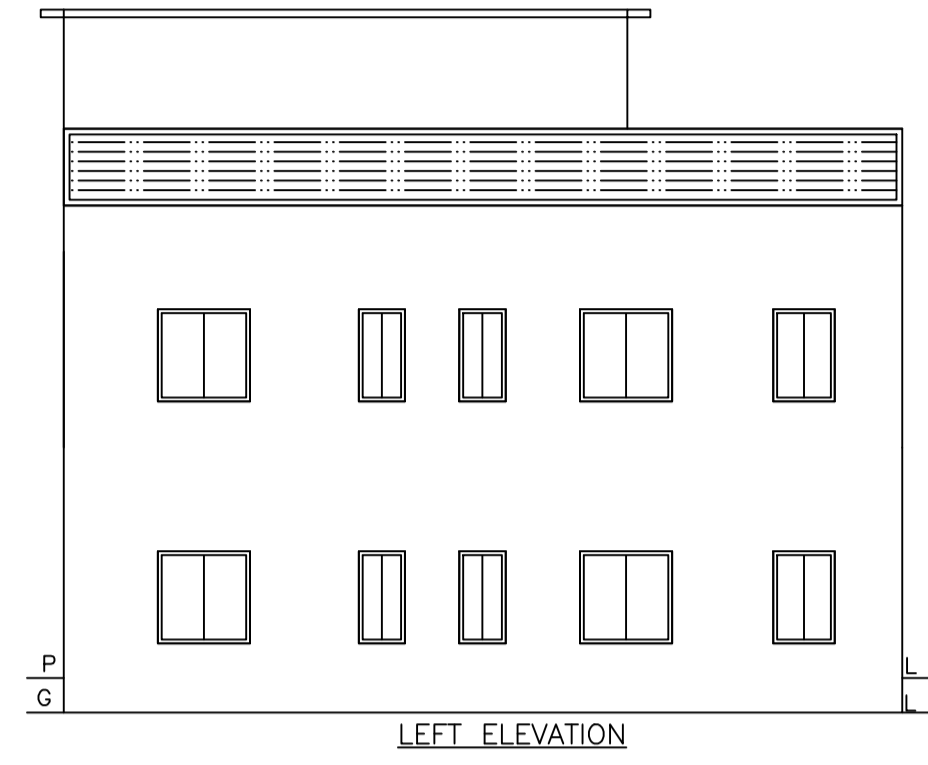
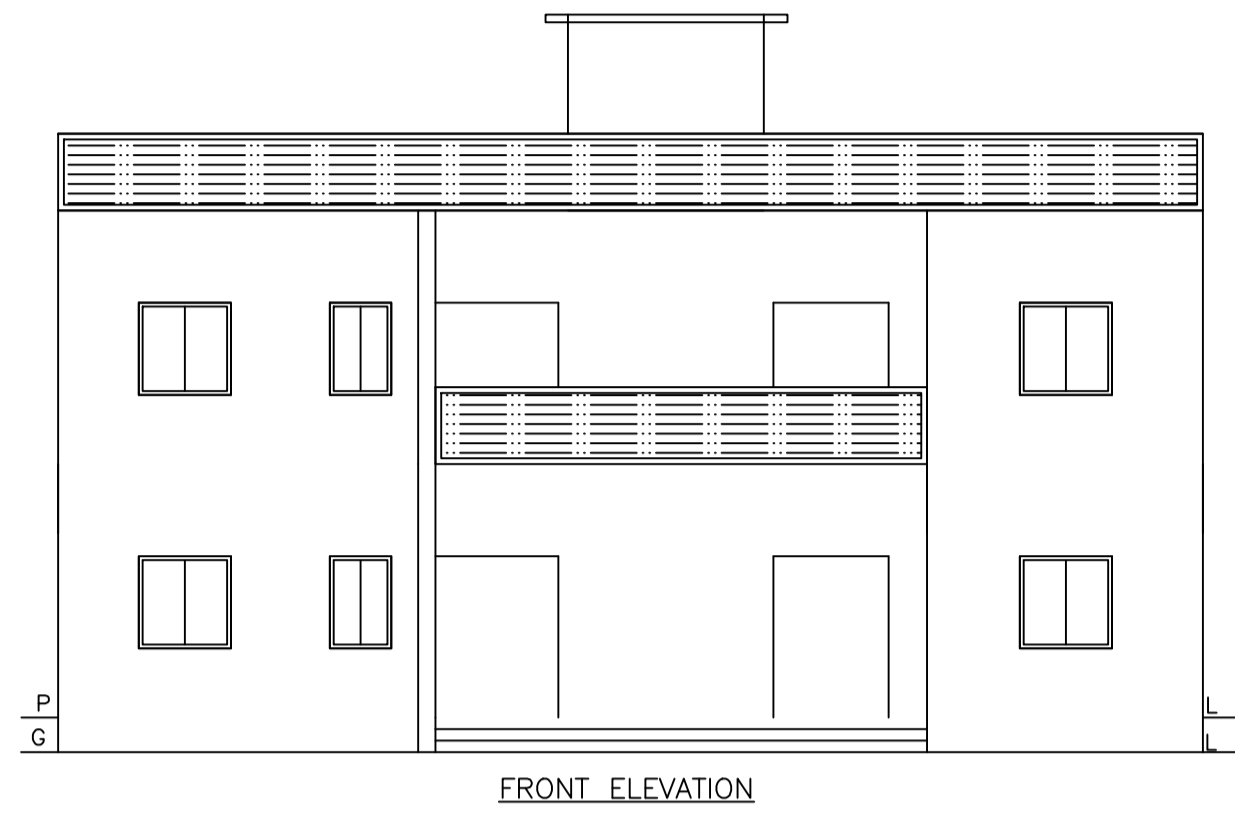

LTP NAME AND SIGNATURE	STRUCTURAL ENG'S NAME AND SIGNATURE	BUILDER NAME AND SIGNATURE	DIGITAL SIGNATURE
ABHISHEK KUMAR DMC/DFTMN/0013/2020			