

Project Title - (1)SMT PINKI SINGH, (2)SMT SUNITA SINGH

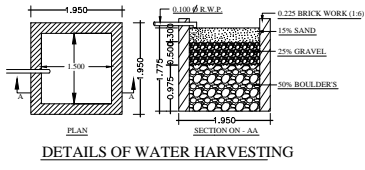

DETAIL OF COLUMNS

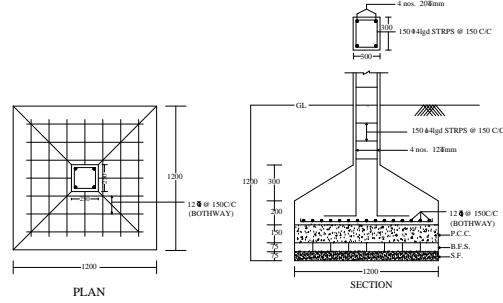
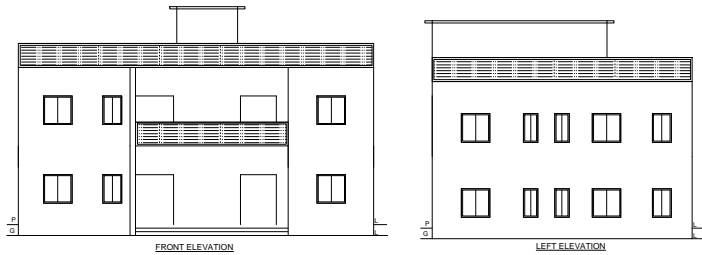
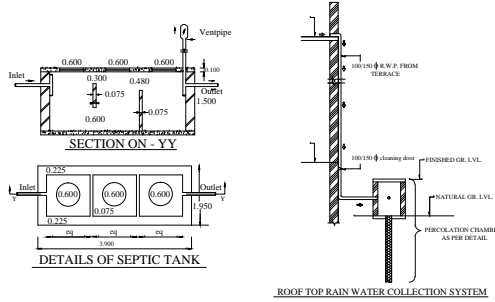

BRIEF SPECIFICATION

FOUNDATION :- R.C.C. (1:1.5:3) Column footing foundation.
 PLINTH :- 12"th R.C.C. (1:1.5:3) all round on plinth level.
 FLOORING :- 1.5"th I.P.S. flooring over 3"th P.C.C. (1:3:6).
 SUPER STRUCTURE :- First class brick work in cement mortar (1:6)
 SLAB,BEAM & LINTEL :- All R.C.C. work (1:1.5:3).
 WOOD WORK :- All door & window frames of sal wood.
 PLASTERING :- 0.5"th cement plaster (1:6) both side.

SCHEDULE

D- 1.000 x 2.100	W- 1.520 x 1.200
D1- 0.900 x 2.100	W1- 1.200 x 1.200
D2- 0.750 x 2.100	W2- 0.900 x 1.200
	V- 0.600 x 0.450

DETAILS OF AREA

TOTAL AREA (AS PER DEED)	267.18 Sqmt.
TOTAL AREA (AS PER SITE)	267.00 Sqmt.
GROUND FLOOR AREA	161.44 Sqmt.
FIRST FLOOR AREA	161.44 Sqmt.
TOTAL COVERED AREA	322.89 Sqmt.
% OF PLINTH AREA	63.42%
F.A.R.	1.26

TITLE OF DRAWING

PROPOSED RESIDENTIAL BUILDING PLAN OF
 (1) SMT PINKI SINGH, W/O SRI BINOD SINGH, (2)SMT SUNITA SINGH, W/O SRI ARUN KUMAR SINGH RESIDENT OF
 (1)KUSTORE MUKHYA CENTRE NEAR KALI MANDIR,
 ALKUSA, DIST - DHANBAD, (2) KENDUA ROAD, NEAR
 HANUMAN MANDIR, KENDUADH, DIST - DHANBAD, UNDER
 MOUZA - SABALPUR, MOUZA NO - 11, KHATA NO - 47 (OLD
 KHATA NO. 4), PLOT NO - 414 (OLD PLOT NO. 556), AREA - 4
 KATHA

SIG. OF OWNER

SIG. OF ENGINEER

DRW. AT :-

