

Proposal Basic Information	
Proposal File No.	DMC/BP/0101/W20/2021
Owner Name	SRI ABHISHEK KUMAR PANDEY
Khata No	OLD- 14, NEW- 210
Plot No	OLD- 358, NEW- 226
Village Name	Baramuri
Use	Residential
SubUse	Bungalow/ Dwelling / Non Apartment

AREA STATEMENT		VERSION NO.: 1.0.55
DHANBAD MUNICIPAL CORPORATION		VERSION DATE: 16/10/2020
PROJECT DETAIL:		
Region: JHARKHAND URBAN LOCAL BODIES	Plot Use: Residential	
District: DHANBAD	Plot SubUse: Bungalow/ Dwelling / Non Apartment	
Authority: DHANBAD MUNICIPAL CORPORATION	Plot/Nearby/Religious/Structure: NA	
Inward No: DMC/BP/0101/W20/2021	Plot/SubPlot No: OLD- 358, NEW- 226	
Application Type: General Proposal	North: Plot No. - SUDHIR GOP	
Project Type: Building Permission	South: Plot No. - PART OF THIS PLOT	
Nature of Development: New	East: Plot No. - PLOT NO. 355	
Location of Development Area: Old Area	West: Plot No. - ARUN VARMA	

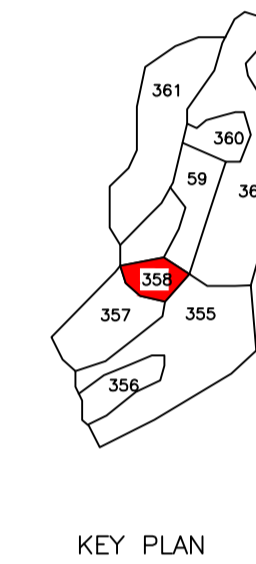
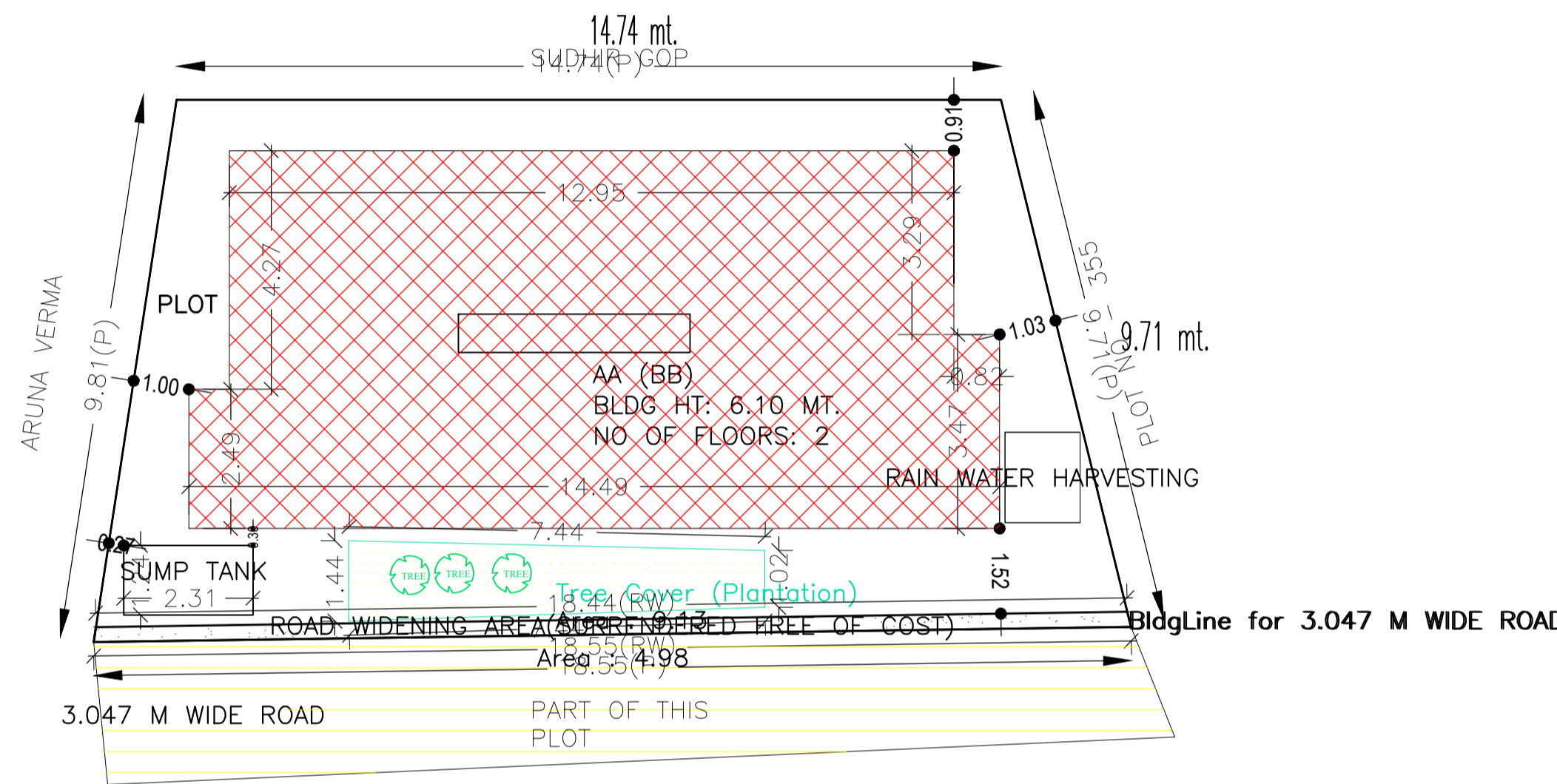
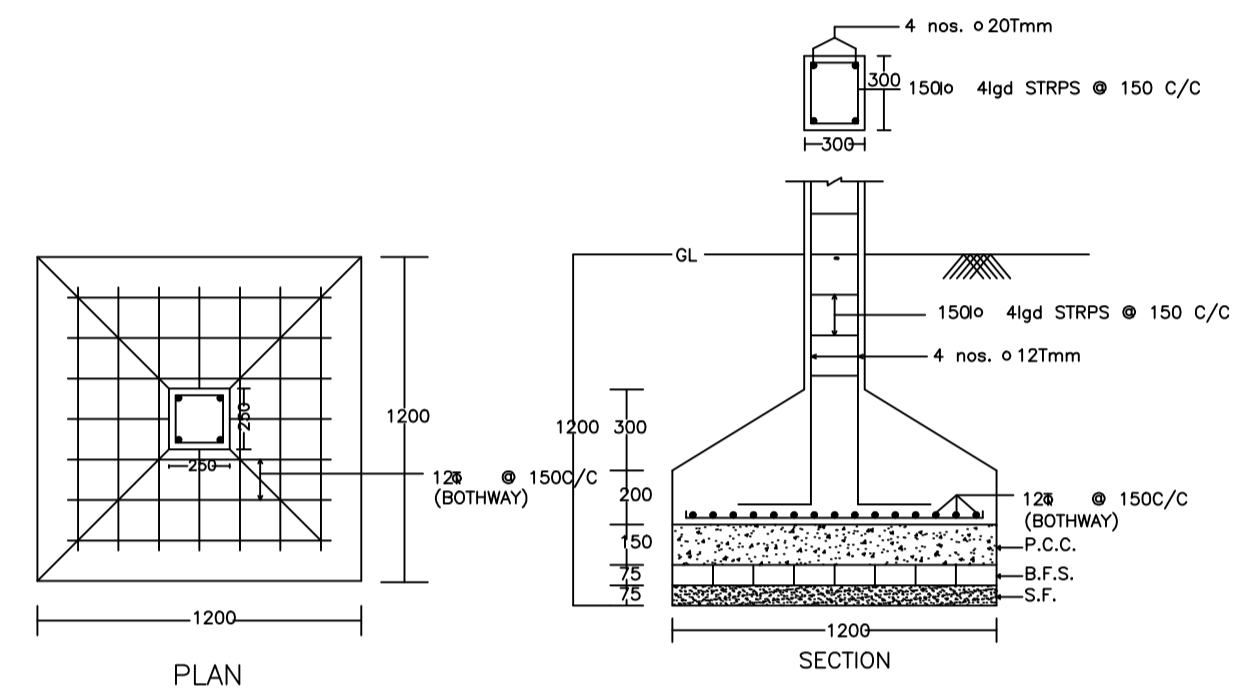

Building :AA (BB)

Floor Name	Total Built Up Area (Sq.mt.)	Proposed FAR Area (Sq.mt.)	Total FAR Area (Sq.mt.)	Total Consumed Additional FAR Area (Sq.mt.)	Tnmt (No.)
Ground Floor	92.14	92.14	92.14	92.14	01
First Floor	92.14	92.14	92.14	92.14	00
Terrace Floor	0.00	0.00	0.00	0.00	00
Total :	184.28	184.28	184.28	184.28	01
Total Number of Same Buildings :	1				
Total :	184.28	184.28	184.28	184.28	01

COLOR INDEX	
PLOT BOUNDARY	Black
ABUTTING ROAD	Red
PROPOSED CONSTRUCTION	Green
COMMON PLOT	Yellow
ROAD WIDENING AREA	Blue
EXISTING (To be retained)	Orange
EXISTING (To be demolished)	Light Blue

Buildingwise Floor FAR Details

Floor Name	Building Name		Total	
	Proposed Built Up Area (Sq.mt.)	Proposed FAR Area (Sq.mt.)	Total Proposed Built Up Area (Sq.mt.)	Total FAR Area (Sq.mt.)
Ground Floor	92.14	92.14	92.14	92.14
First Floor	92.14	92.14	92.14	92.14
Terrace Floor	0.00	0.00	0.00	0.00
Total :	184.28	184.28	184.28	184.28

Building USE/SUBUSE Details

Building Name	Building Use	Building SubUse	Building Structure
AA (BB)	Residential	Bungalow/ Dwelling / Non Apartment	Non-Highrise

AREA DETAILS:		SQ.MT.
AREA OF PLOT (Minimum)	(A)	159.15
Deduction for NetPlot Area		
Surrender Free of Cost		4.98
Total		4.98
NET AREA OF PLOT(Gross Plot Area - Deduction from Gross Plot area)	(A-Deductions)	154.17
Deduction for Balance Plot Area(from Gross Plot Area)		
Surrender Free of Cost		4.98
Common Plot		9.13
Total		14.11
BALANCE AREA OF PLOT(Net Plot Area - Recreational/Amenity space)	(A-Deductions)	145.04
PLOT AREA FOR COVERAGE(Net Plot Area)	(A-Deductions)	154.17
Plot Area for FAR (Net Plot Area + Road Widening Area)	(A-Deductions)	159.15
COVERAGE CHECK		
Permissible Coverage area (70.00 %)		107.92
Proposed Coverage Area (59.77 %)		92.14
Total Prop. Coverage Area (59.77 %)		92.14
Balance coverage area (10.24 %)		15.78
FAR CHECK		
Perm. FAR Area (1.20)		190.98
Total Perm. FAR area		190.98
Residential FAR		184.27
Proposed FAR Area		184.27
Total Proposed FAR Area		184.27
Consumed FAR (Factor)		1.16
Balance FAR Area		6.71
BUILT UP AREA CHECK		
Total Proposed BuiltUp Area		184.28
ARCHITECT (Regd)		
ENGINEER (Regd)		
SUPERVISOR (Regd)		
OWNER (Regd)		
DEVELOPMENT AUTHORITY		
LOCAL BODY		

UnitBUA Table for Building :AA (BB)

FLOOR	Name	UnitBUA Type	UnitBUA Area	Carpet Area	No. of Rooms	No. of Tenement
GROUND FLOOR PLAN	SPLIT AA	FLAT	184.27	183.99	6	1
FIRST FLOOR PLAN	SPLIT AA	FLAT	0.00	0.00	6	0
Total:	-	-	184.27	183.99	12	1

FAR & Tenement Details (Table 4c-1)

Building	No. of Same Bldg	Total Built Up Area (Sq.mt.)	Proposed FAR Area (Sq.mt.)	Total FAR Area (Sq.mt.)	Total Consumed Additional FAR Area (Sq.mt.)	Tnmt (No.)
AA (BB)	1	184.28	184.28	184.28	184.28	01
Grand Total :	1	184.28	184.28	184.28	184.28	01

SCHEDULE OF DOOR:

BUILDING NAME	NAME	LENGTH	HEIGHT	NOS
AA (BB)	D	0.76	2.10	02
AA (BB)	D	0.90	2.10	02
AA (BB)	D	0.91	2.10	04
AA (BB)	D	1.13	2.10	02
AA (BB)	D	1.22	2.10	02

SCHEDULE OF WINDOW/VENTILATION:

BUILDING NAME	NAME	LENGTH	HEIGHT	NOS
AA (BB)	W	0.61	1.20	02
AA (BB)	W	0.91	1.20	06
AA (BB)	W	1.22	1.20	08
AA (BB)	W	1.52	1.20	04

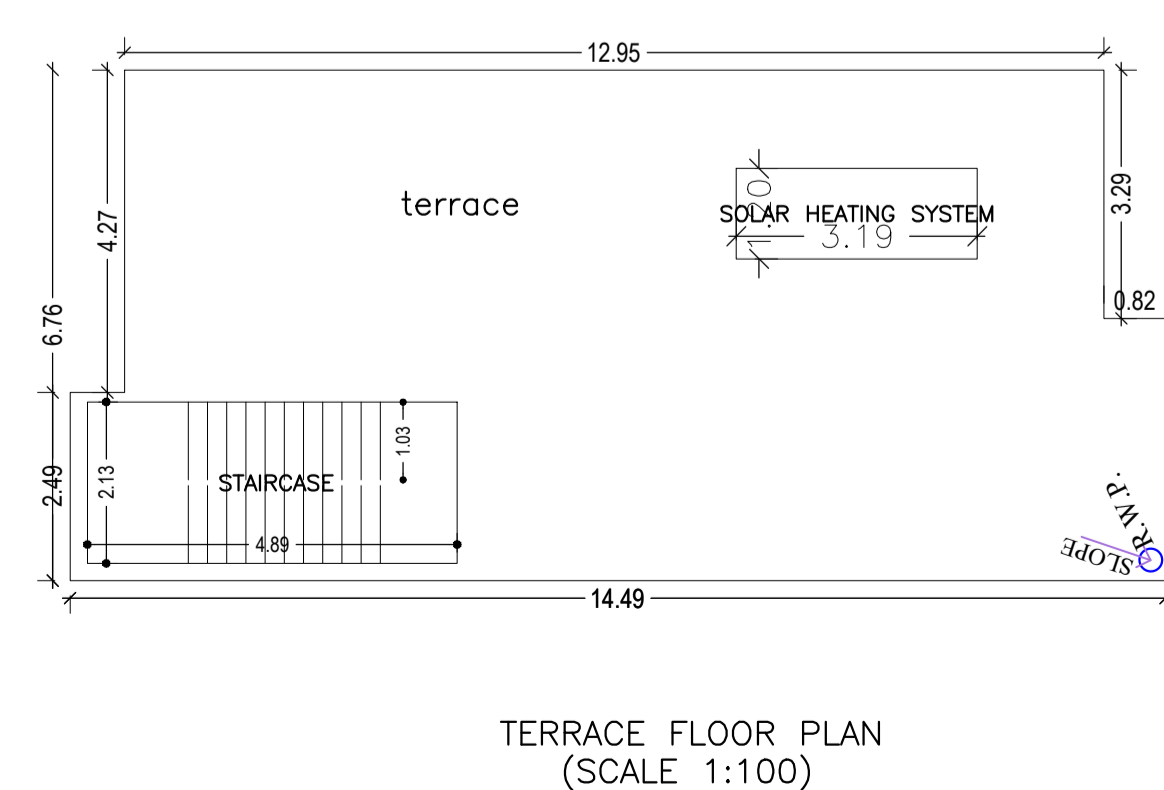
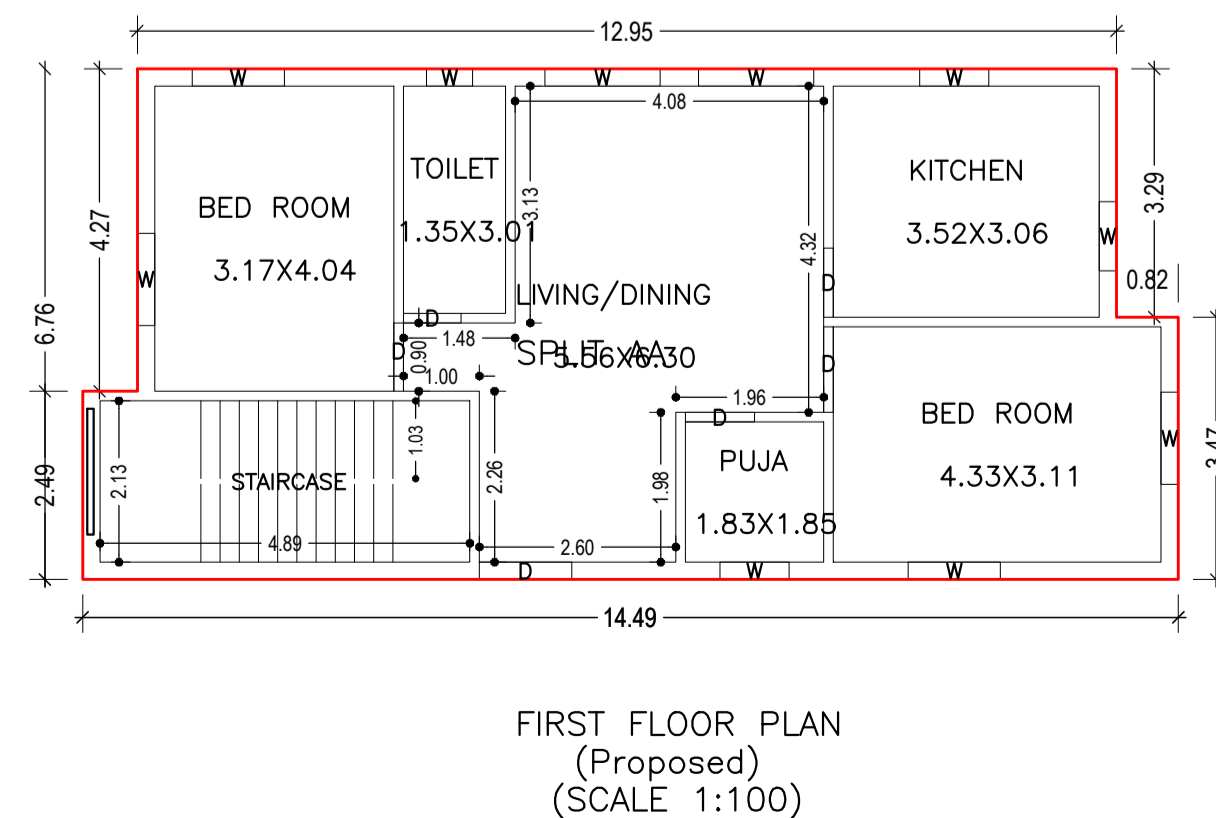
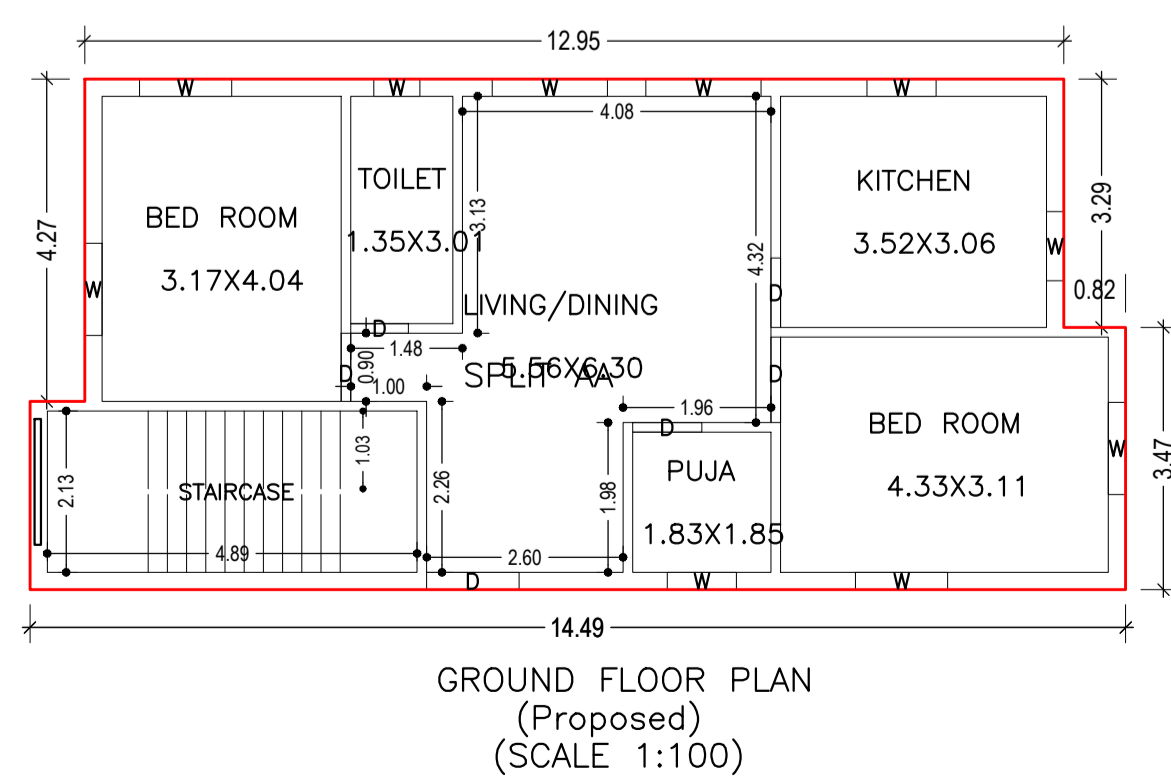
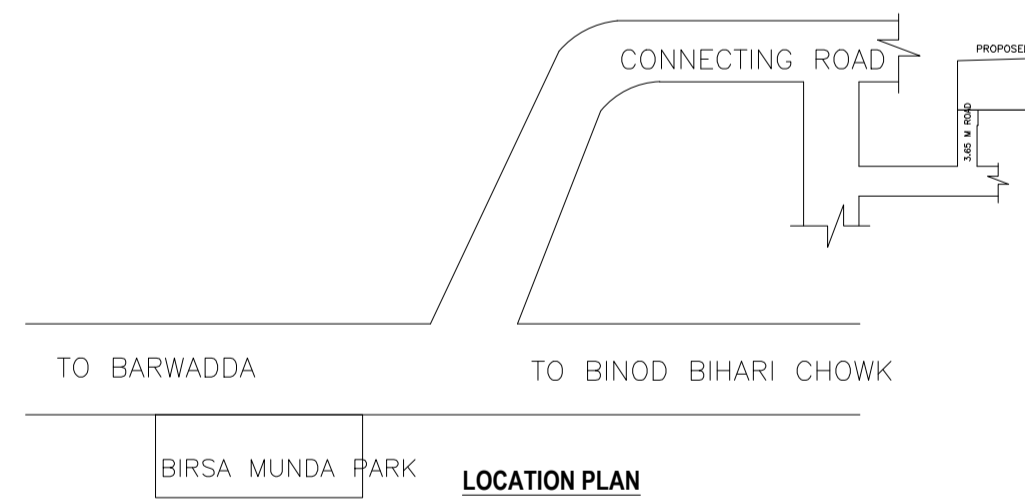
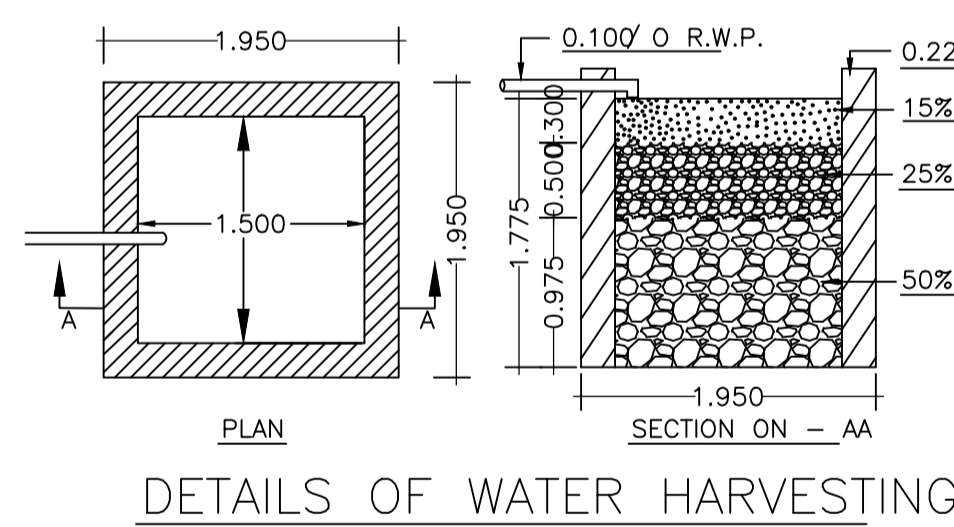
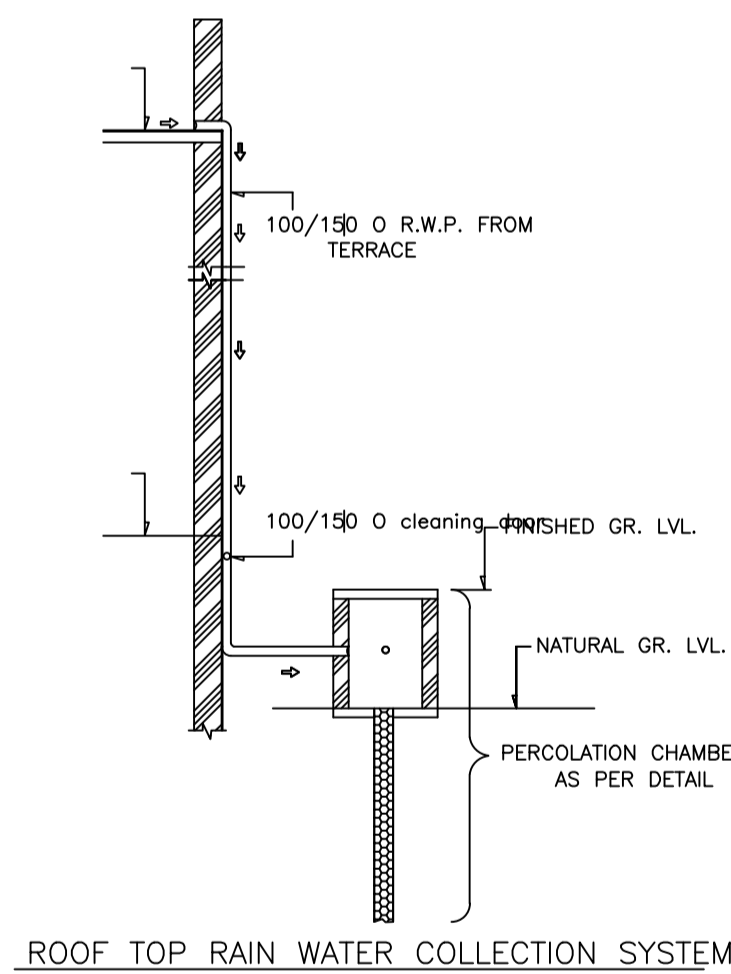

LTP NAME AND SIGNATURE	STRUCTURAL ENG'S NAME AND SIGNATURE	BUILDER NAME AND SIGNATURE	DIGITAL SIGNATURE
ABHISHEK KUMAR DMC/DFTM/0013/2020			