

Project Title : DEONARAYAN PRASAD

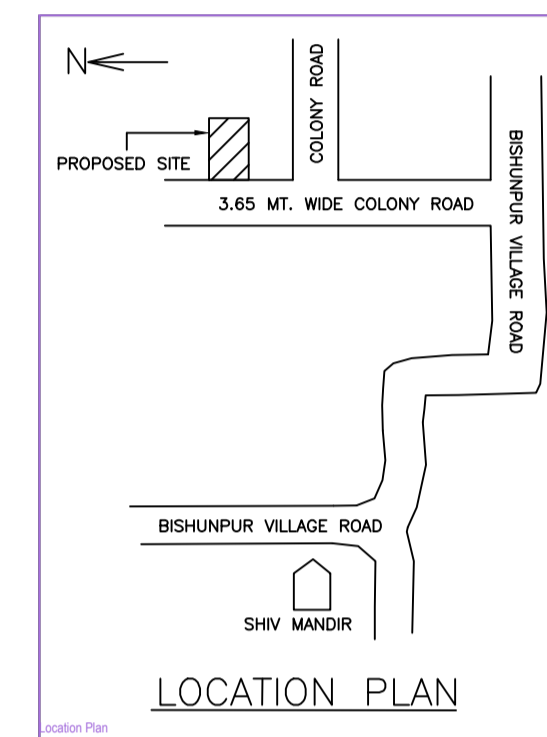
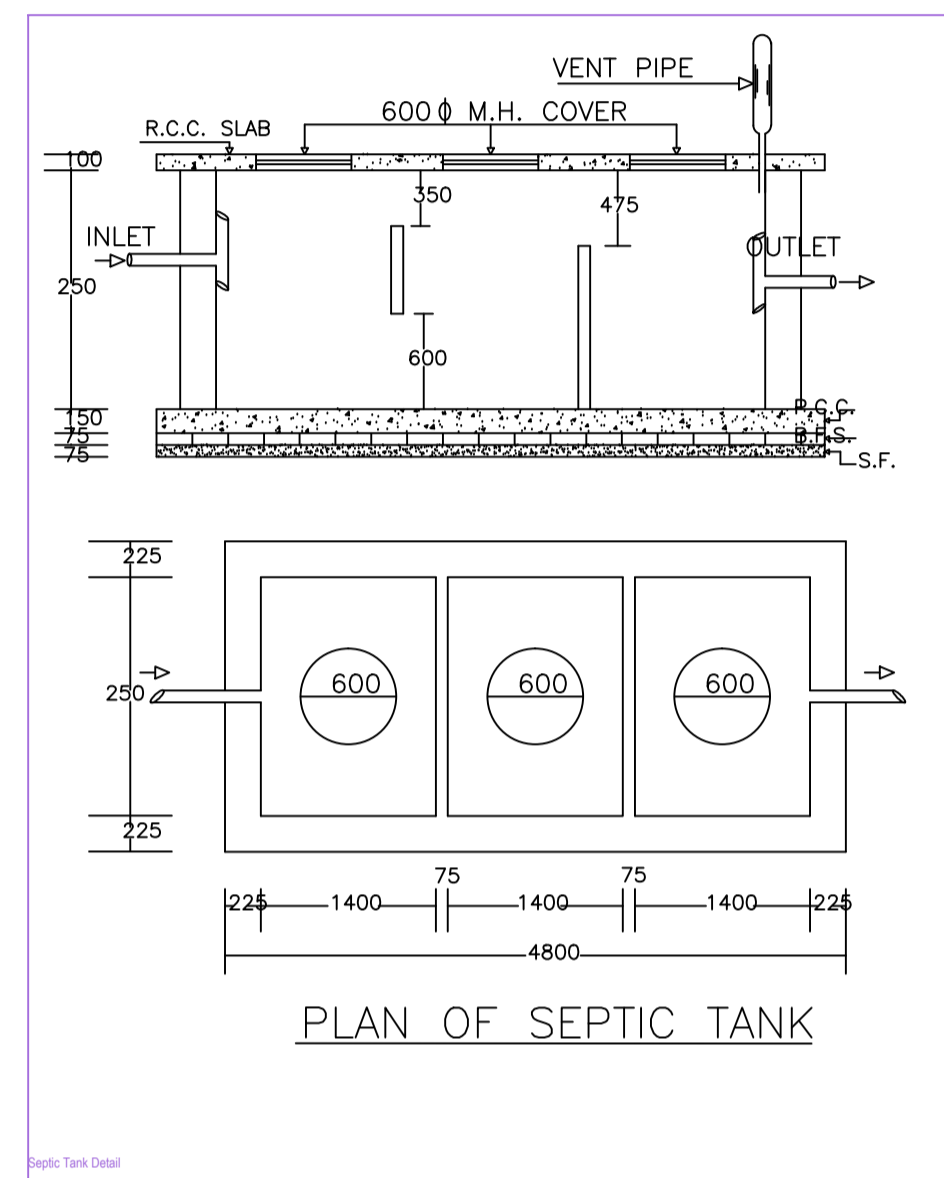
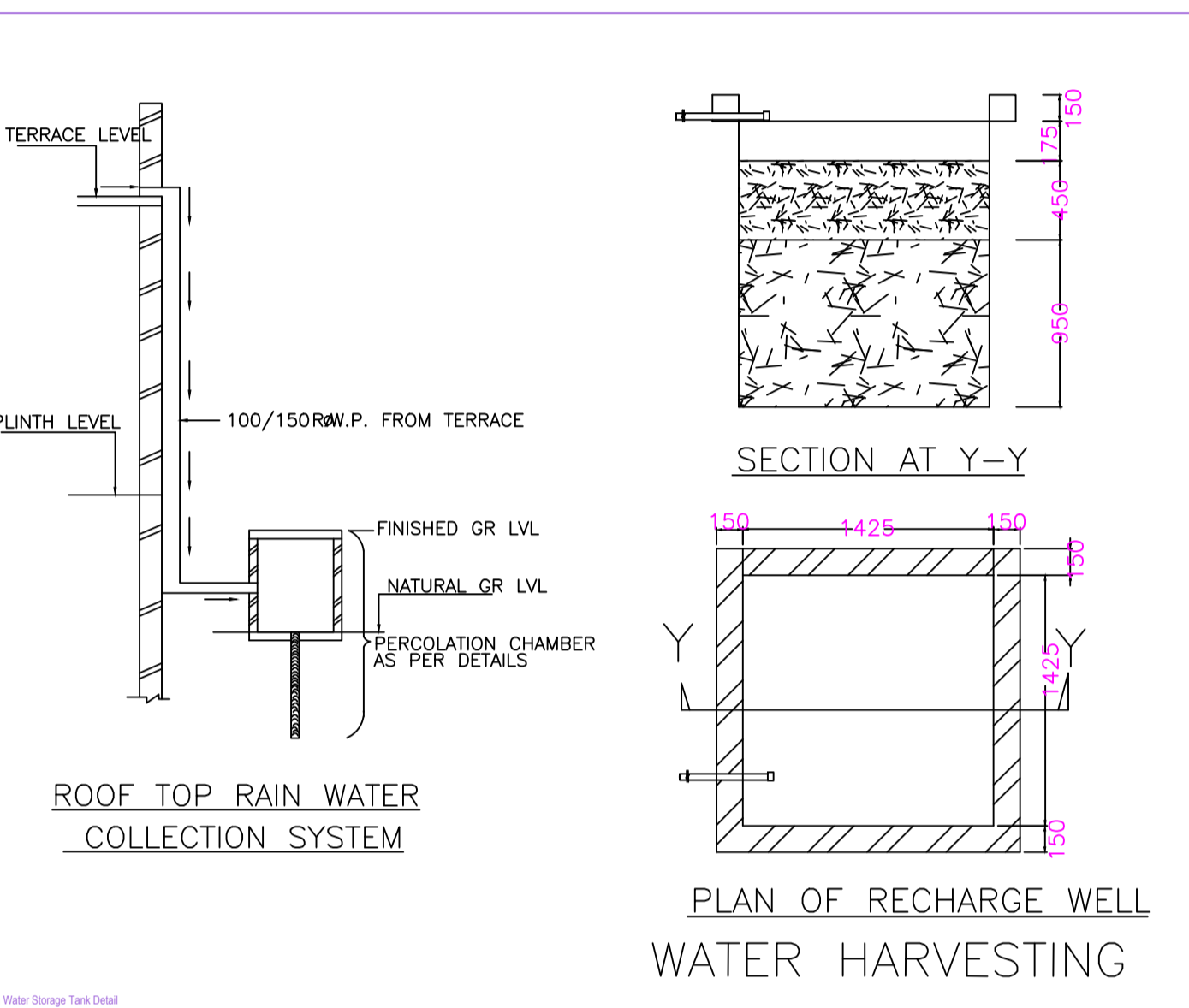
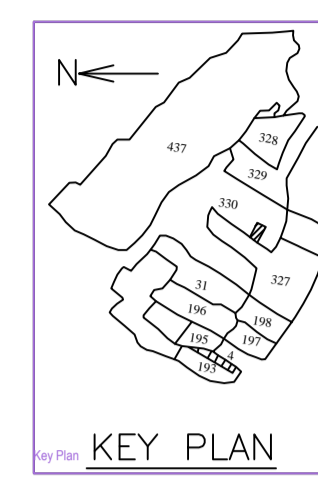
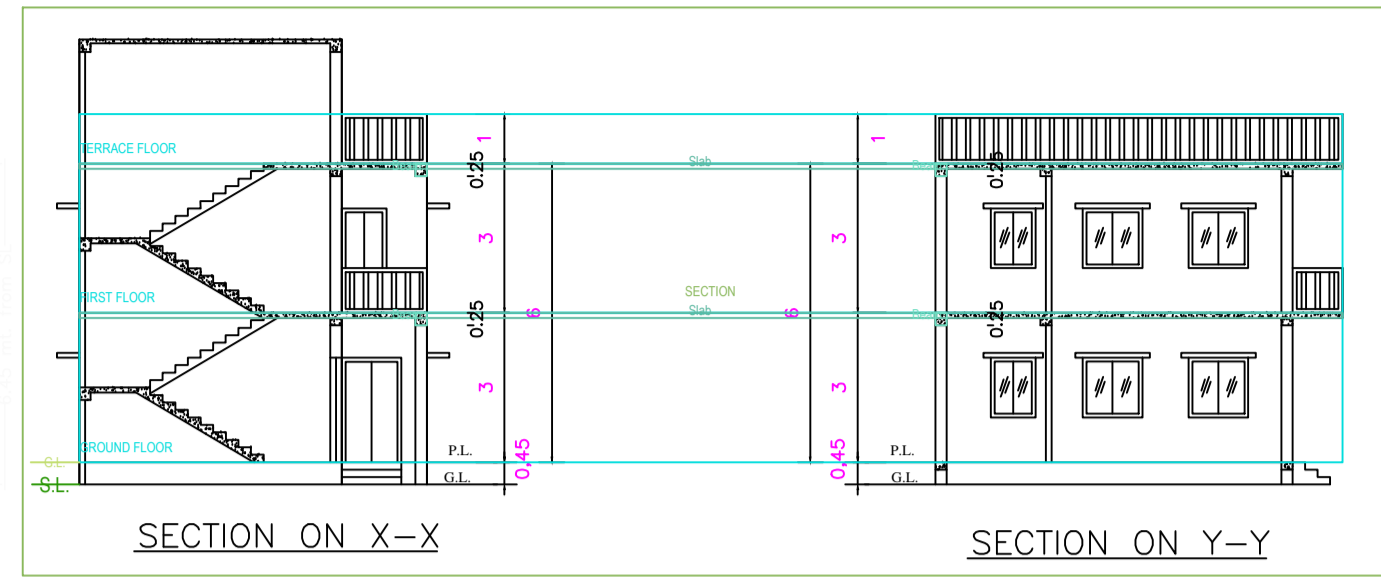
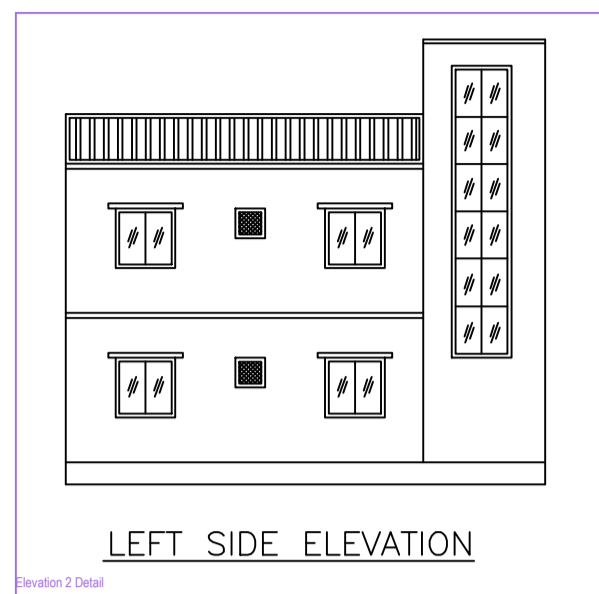
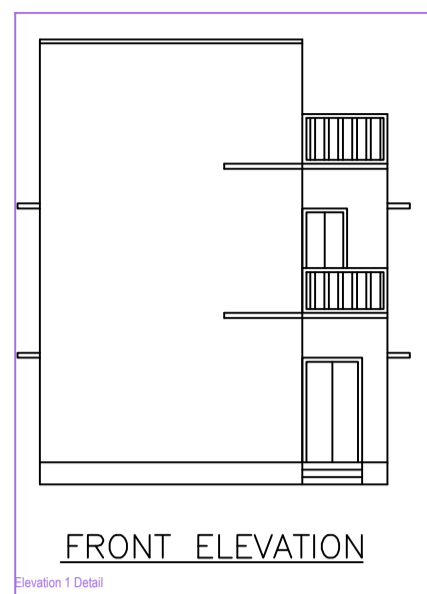

BRIEF SPECIFICATION

FOUNDATION----- CEMENT CONCRETE (1:1.5:3)
 BRICK WORK IN FOUNDATION & SUPERSTRUCTURE
 FIRST CLASS BRICK WORK IN CEMENT MORTAR (1:6)
 D.P.C.-----25 D.P.C. IN CEMENT CONCRETE (1:2:4)
 FLOOR-----25 I.P.S. OVER 75 P.C.C.
 ROOF-----100 THK. R.C.C. ROOF (1:1.5:3)
 LINTEL-----150 THK. R.C.C. LINTEL (1:1.5:3)
 STAIRS----- RISE-- 150, TREAD-- 250

DETAILS OF AREA

TOTAL LAND AREA (AS PER DEED) ---	133.54 SQM.
TOTAL LAND AREA (AS PER SITE) ---	118.23 SQM.
GROUND FLOOR AREA-----	64.73 SQM.
FIRST FLOOR AREA-----	64.73 SQM.
TOTAL COVERED AREA-----	129.46 SQM.
% PLINTH AREA-----	54.74 %
FAR -----	1.09

SCHEDULE

D = 1.200X2.100	W = 1.200X1.200
D1 = 1.050X2.100	W1 = 0.900X1.200
D2 = 0.900X2.100	V = 0.600X0.600
D3 = 0.750X2.100	

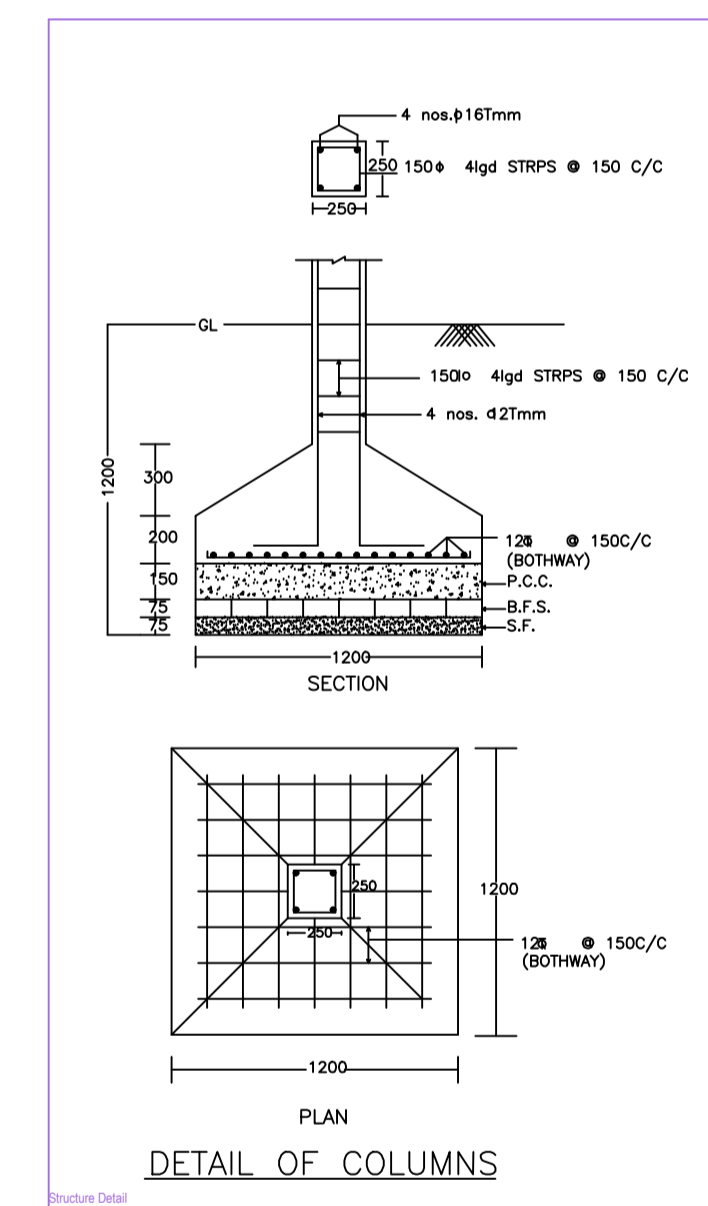
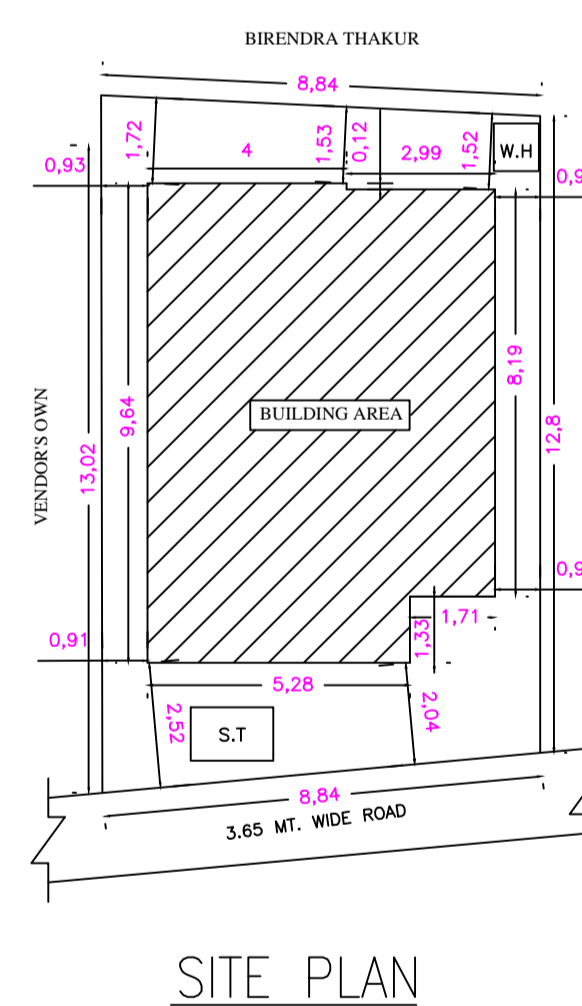
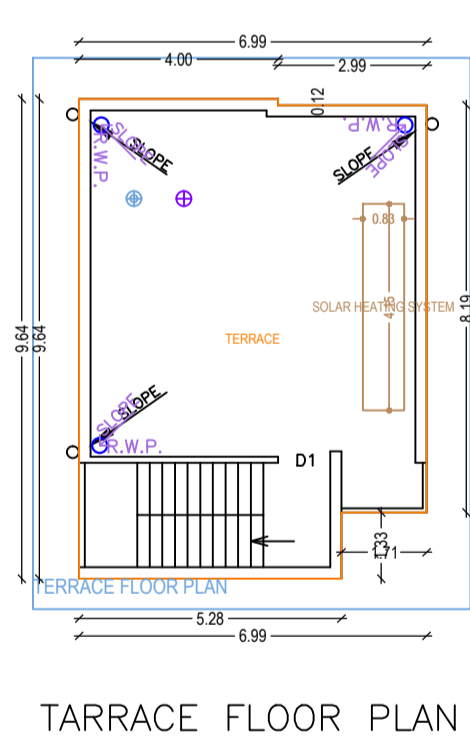
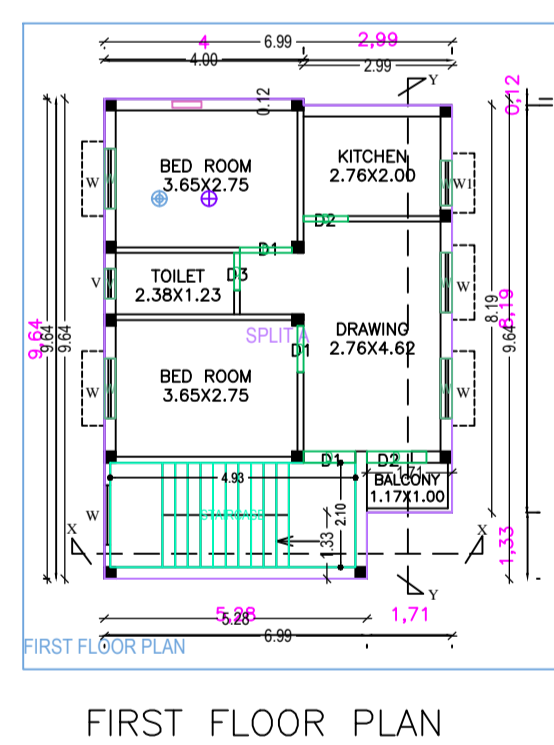
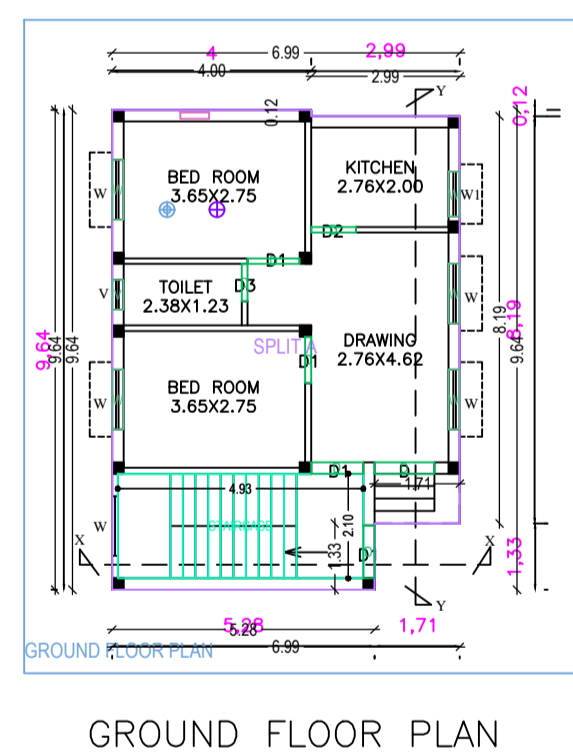
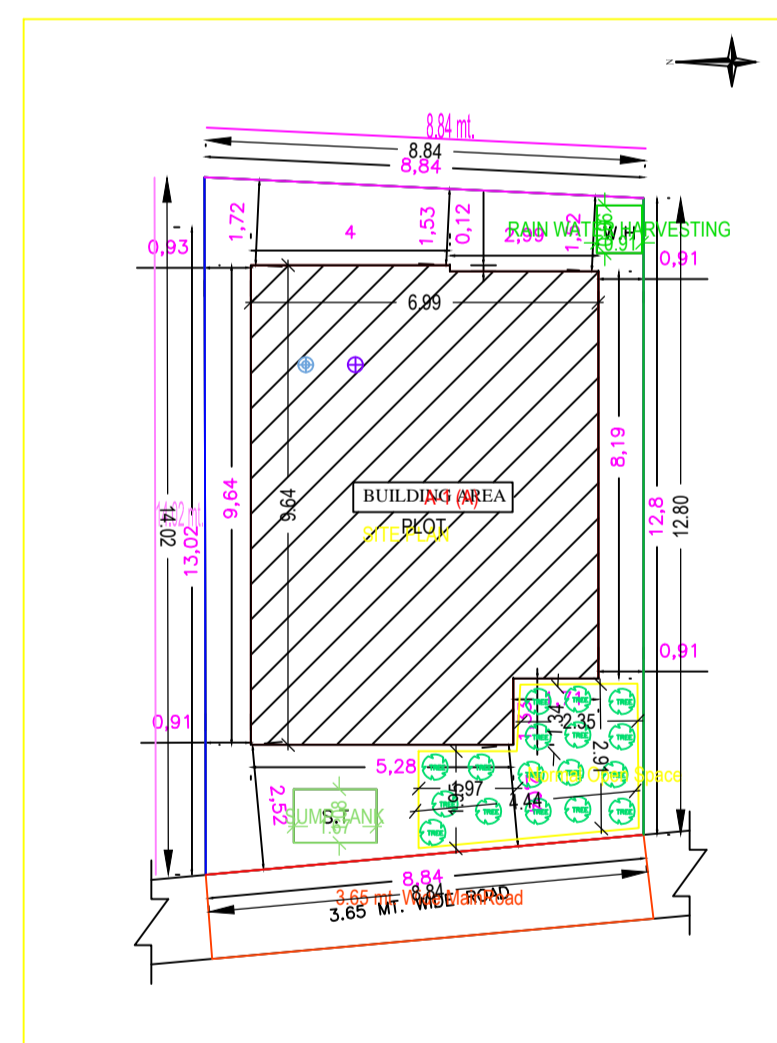

TITLE OF DRAWING

PLAN OF PROPOSED RESIDENTIAL BUILDING OF SRI. DEONARAYAN PRASAD, S/O.- LATE RAM CHANDAR LAL, OF OFFICER COLONY N.H. QUATER, DHANBAD, P.S. + DIST. DHANBAD. UNDER MOUZA - BARAMURI, NO.- 3, KHATA NO.- 34, PLOT NO.- 330 IN THE DISTT. OF DHANBAD (JHARKHAND).

SIGNATURE OF OWNER

SIGNATURE OF ENGINEER

SCALE ALL DIMENSION ARE IN METRE

Building : A (A)

Floor Name	Total Built Up Area (Sq.mt.)	Proposed FAR Area (Sq.mt.)	Total FAR Area (Sq.mt.)	Tent (No.)
Ground Floor	64.74	64.74	64.74	01
First Floor	64.74	64.74	64.74	01
Terrace Floor	0.00	0.00	0.00	00
Total	129.48	129.48	129.48	01
Total Number of Same Buildings	1			
Total	129.48	129.48	129.48	01

SCHEDULE OF JOINERY:

BUILDING NAME	NAME	LENGTH	HEIGHT	NOS
A (A)	D	0.75	2.10	02
A (A)	D	0.90	2.10	02
A (A)	D	0.94	2.10	02
A (A)	D	1.05	2.10	04
A (A)	D	1.07	2.10	01
A (A)	D	1.20	2.10	02
Total	-	-	-	13

SCHEDULE OF JOINERY:

BUILDING NAME	NAME	LENGTH	HEIGHT	NOS
A (A)	V	0.60	1.00	02
A (A)	W	0.90	1.20	
A (A)	W	1.20	1.20	
Total	-	-	-	

UnitBUA Table for Building : A (A)

FLOOR	UnitBUA Type	UnitBUA Area	Carpet Area	No. of Tenement
GROUND FLOOR PLAN	SPLIT A	FLAT	129.48	1
Total	-	-	129.48	1

AREA STATEMENT	VERSION NO.	VERSION DATE
DHANBAD MUNICIPAL CORPORATION	1.0.27	16/10/2020

PROJECT DETAIL:

Project No.:	Plot No.:
Region : JHARKHAND URBAN LOCAL BODIES	Plot Subcode : Bungalow/ Dwelling / Non Apartment
District : DHANBAD	Land Use Zone : NA
Application Type : General Proposal	Building Road Width : -
Project Type : Building Permission	Plot No. : -
Nature of Development : New	Revenue Survey No/Survey No : -
Location : Old Area	Thana No. : -
Sub Location : NA	Heating No. : -
Village/Mauza Name : -	Khata No. : -
Ward No. : -	North : -
Road/Street : -	South : -
	East : -
	West : -

AREA DETAILS:

AREA OF PLOT (Minimum)	(A)	118.24
Net Plot Area (Gross Plot Area - Deduction from Gross Plot Area)		118.24
Deductions for Balance Plot Area from Gross Plot Area		0.00
Balloon Plot Area (Net Plot Area - Recreational/Amenity space)	(A-Deductions)	107.27
Plot Area for Coverage (Net Plot Area)	(A-Deductions)	118.24
Plot Area for FSI (Net Plot Area + Road/Widening Area)	(A-Deductions)	118.24

COVERAGE CHECK

Proposed Coverage Area (Sq.M ²)	64.73
Total Coverage Area (Sq.M ²)	64.73

FAR CHECK

Proposed Area of FAR	129.48
Total Area of FAR	129.48

BUILT UP AREA CHECK

Total Proposed Built Up Area	129.48
------------------------------	--------

ARCH ENGR/ SUPERVISOR (Regd)

OWNER

DEVELOPMENT AUTHORITY

LOCAL BODY

COLOR INDEX

Plot Boundary	Green
Abutting Road	Red
Proposed Work (Coverage Area)	Blue
Existing (To be retained)	Yellow
Existing (To be demolished)	White

Color Index MARGIN DETAIL:

Building / Wing Name	Road Name	Front Margin	Rear Margin	Side Margin	Side2 Margin
A (A)	3.65 MT. WIDE COLONY ROAD	2.04	1.52	0.91	0.91

FAR & Tenement Details (Table 4c-1)

Building	Total Built Up Area (Sq.mt.)	Proposed FAR Area (Sq.mt.)	Total FAR Area (Sq.mt.)	Tent (No.)
A (A)	129.48	129.48	129.48	01
Grand Total	129.48	129.48	129.48	01