

Proposal Basic Information

Proposal File No.	DMC/BP/0096/W21/2021
Owner Name	KAVITA GORAI
Khata No	90
Plot No	17
Village Name	Dhaiya
Use	Residential
SubUse	Bungalow/ Dwelling / Non Apartment

AREA STATEMENT

VERSION NO.:	1.0.58	SQ.MT.
VERSION DATE:	16/10/2020	
Region: JHARKHAND URBAN LOCAL BODIES	Plot Use: Residential	
District: DHANBAD	Plot SubUse: Bungalow/ Dwelling / Non Apartment	
Authority: DHANBAD MUNICIPAL CORPORATION	PlotNearby/ReligiousStructure: NA	
Inward No. DMC/BP/0096/W21/2021	Plot/SubPlot No: 17	
Application Type: General Proposal	North: Plot No. - PART OF SAME PLOT	
Project Type: Building Permission	South: Road Width - PART OF SAME PLOT	
Nature of Development: New	East: Plot No. - BINDA KUMARI	
Location of Development Area: Old Area	West: Road Width - 7.62	
AREA OF PLOT (Minimum)	(A)	118.24
Deduction for NetPlot Area		
Surrender Free of Cost		2.36
Total		2.36
NET AREA OF PLOT(Gross Plot Area - Deduction from Gross Plot area)	(A-Deductions)	115.89
Deduction for Balance Plot Area(from Gross Plot Area)		
Surrender Free of Cost		2.36
Common Plot		14.10
Total		16.46
BALANCE AREA OF PLOT(Net Plot Area - Recreational/Amenity space)	(A-Deductions)	101.79
PLOT AREA FOR COVERAGE(Net Plot Area)	(A-Deductions)	115.89
Plot Area for FAR (Net Plot Area + RoadWidening Area)	(A-Deductions)	118.24
COVERAGE CHECK		
Permissible Coverage area ( 70.00 % )		81.12
Proposed Coverage Area ( 57.52 % )		66.66
Total Prop. Coverage Area ( 57.52 % )		66.66
Balance coverage area ( 12.48 % )		14.46
FAR CHECK		
Perm. FAR Area ( 1.50 )		177.36
Total Perm. FAR area		177.36
Residential FAR		133.32
Proposed FAR Area		133.32
Total Proposed FAR Area		133.32
Consumed FAR (Factor)		1.13
Balance FAR Area		44.04
BUILT UP AREA CHECK		
Total Proposed BuiltUp Area		133.32
ARCHITECT (Regd)	SANJEEV KUMAR RAY	
ENGINEER (Regd)		
SUPERVISOR (Regd)		
OWNER (Regd)	KAVITA GORAI	
DEVELOPMENT AUTHORITY	LOCAL BODY	

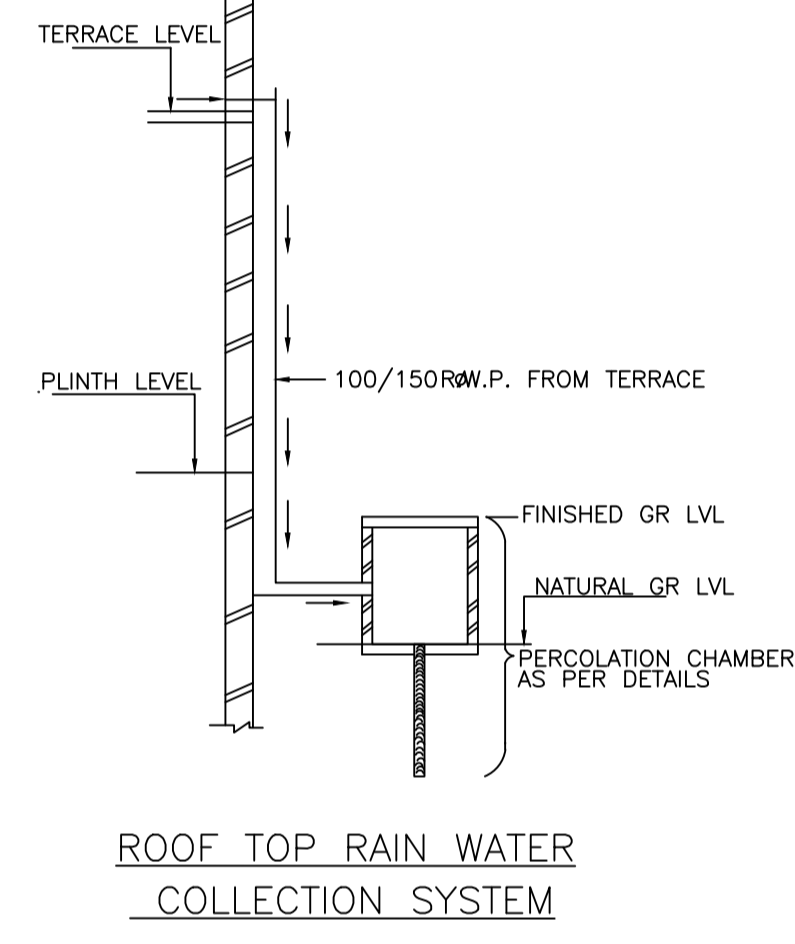
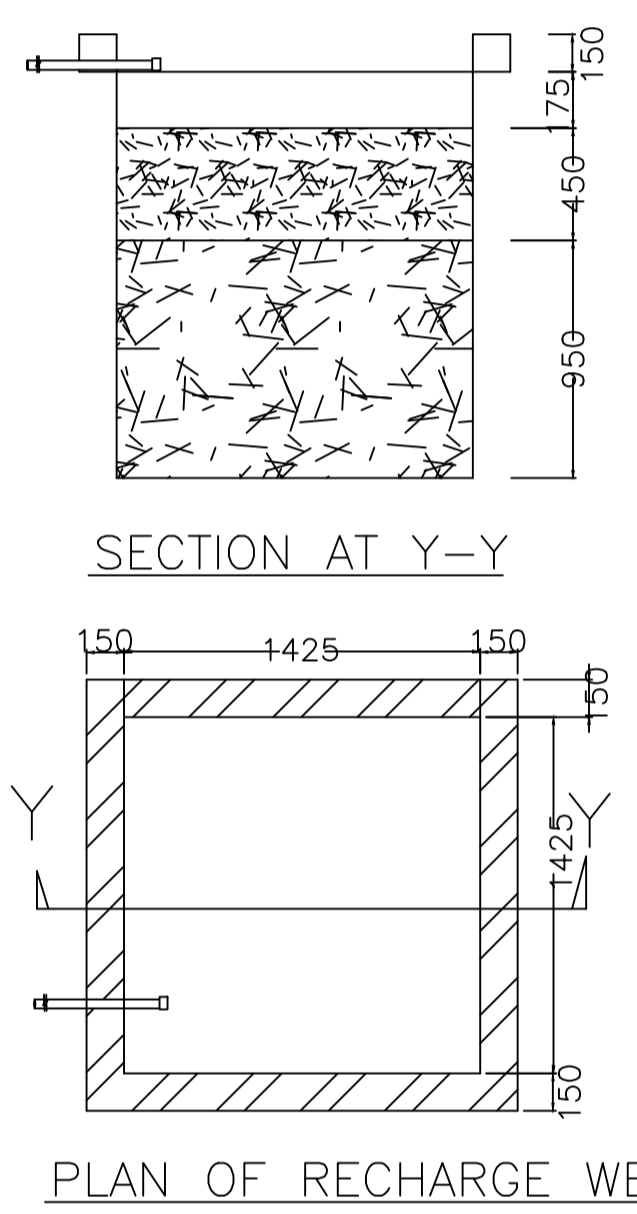
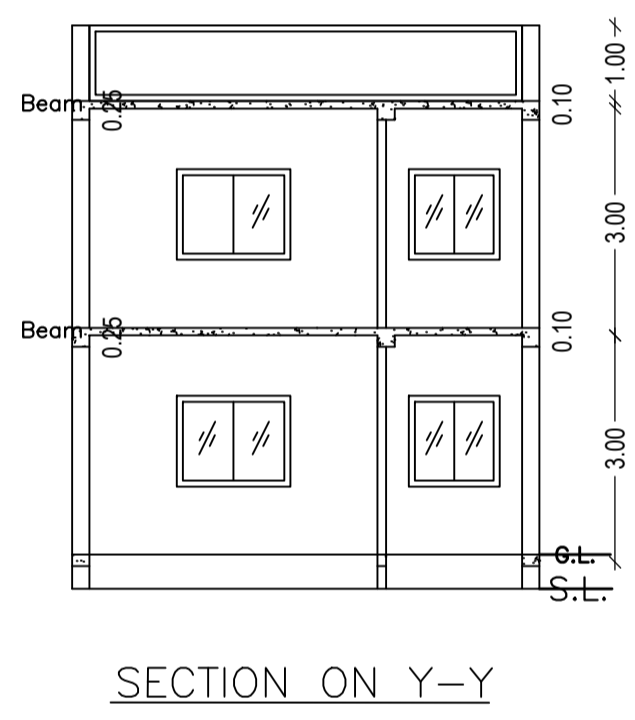
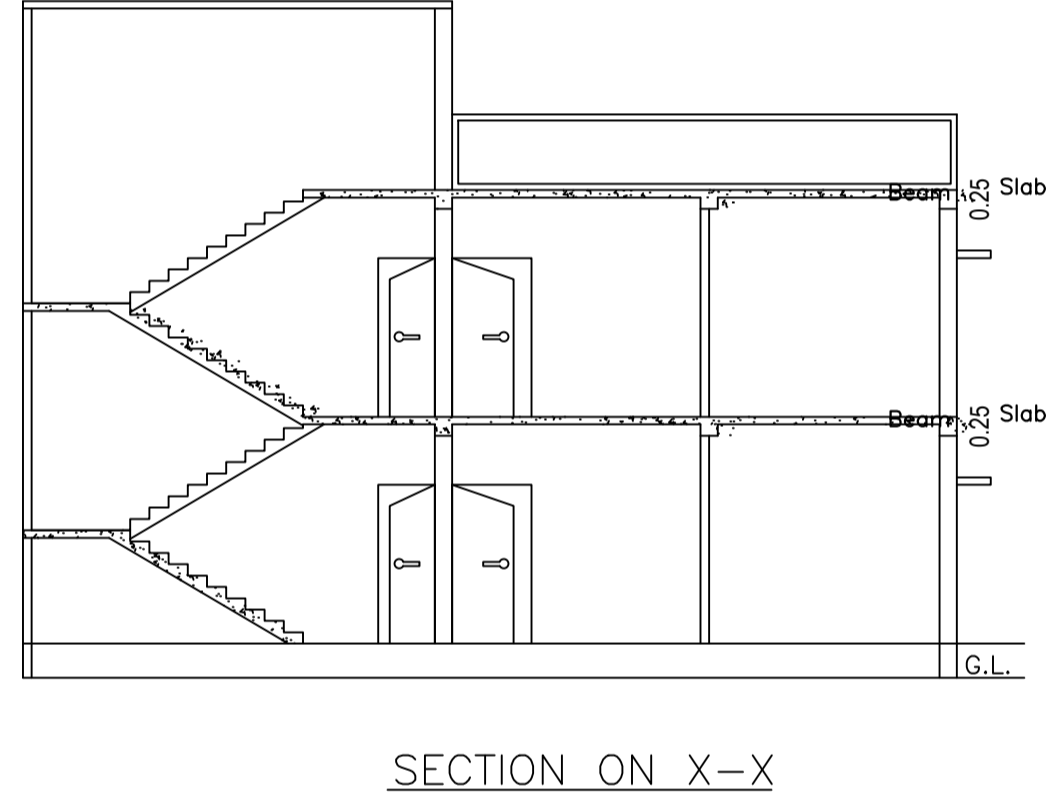
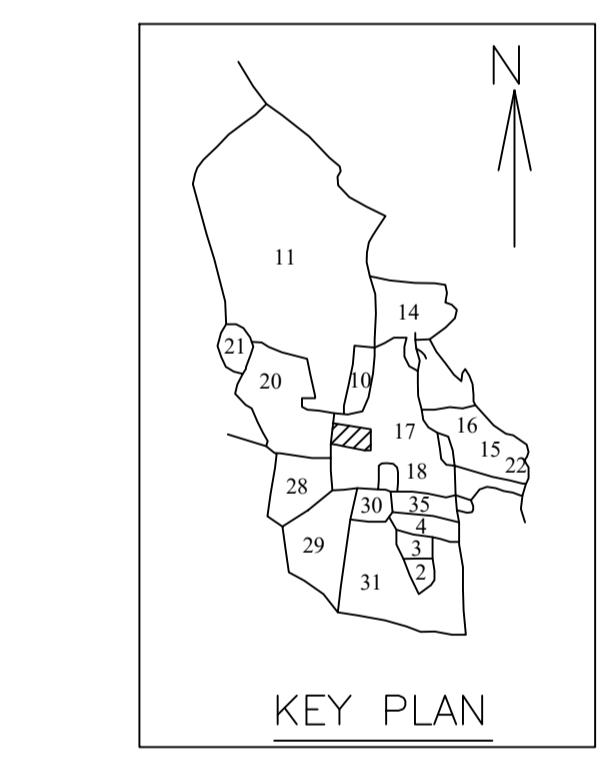

WATER HARVESTING

Building USE/SUBUSE Details

Building Name	Building Use	Building SubUse	Building Structure
A (A)	Residential	Residential Bldg/Apartment	Non-Highrise

Building :A (A)

Floor Name	Total Built Up Area (Sq.mt.)	Proposed FAR Area (Sq.mt.) Resi.	Total FAR Area (Sq.mt.)	Total Consumed Additional FAR Area (Sq.mt.)	Tnmt (No.)
Ground Floor	66.66	66.66	66.66	66.66	01
First Floor	66.66	66.66	66.66	66.66	00
Terrace Floor	0.00	0.00	0.00	0.00	00
Total	133.32	133.32	133.32	133.32	01
Total Number of Same Buildings	1				
Total	133.32	133.32	133.32	133.32	01

SCHEDULE OF DOOR:

BUILDING NAME	NAME	LENGTH	HEIGHT	NOS
A (A)	D	0.75	2.10	02
A (A)	D	0.80	2.10	02
A (A)	D	0.90	2.10	01
A (A)	D	1.05	2.10	05

SCHEDULE OF WINDOW/VENTILATION:

BUILDING NAME	NAME	LENGTH	HEIGHT	NOS
A (A)	V	0.60	1.20	02
A (A)	W	1.20	1.20	02
A (A)	W	1.50	1.20	10

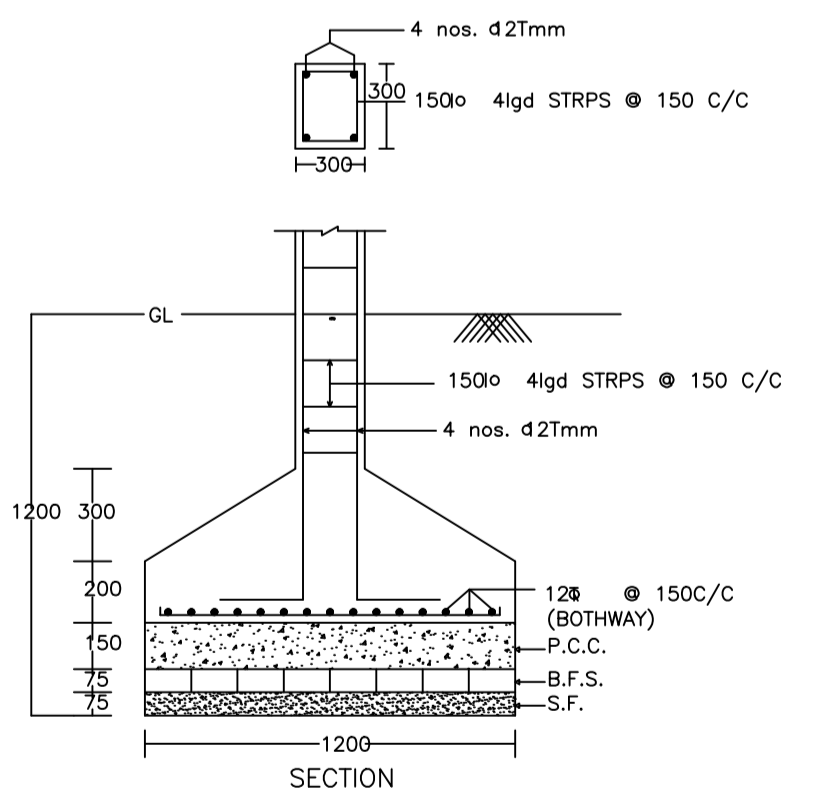
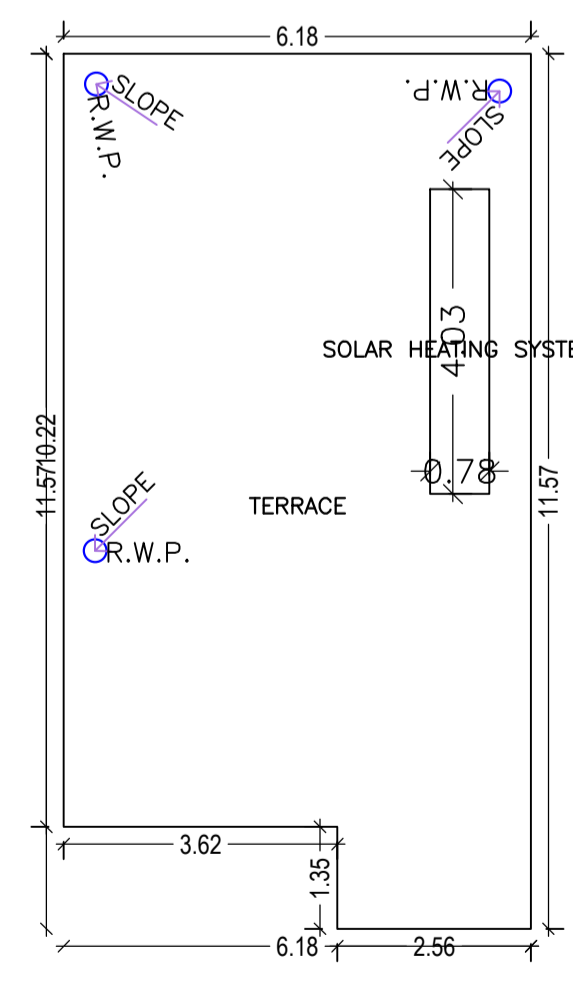
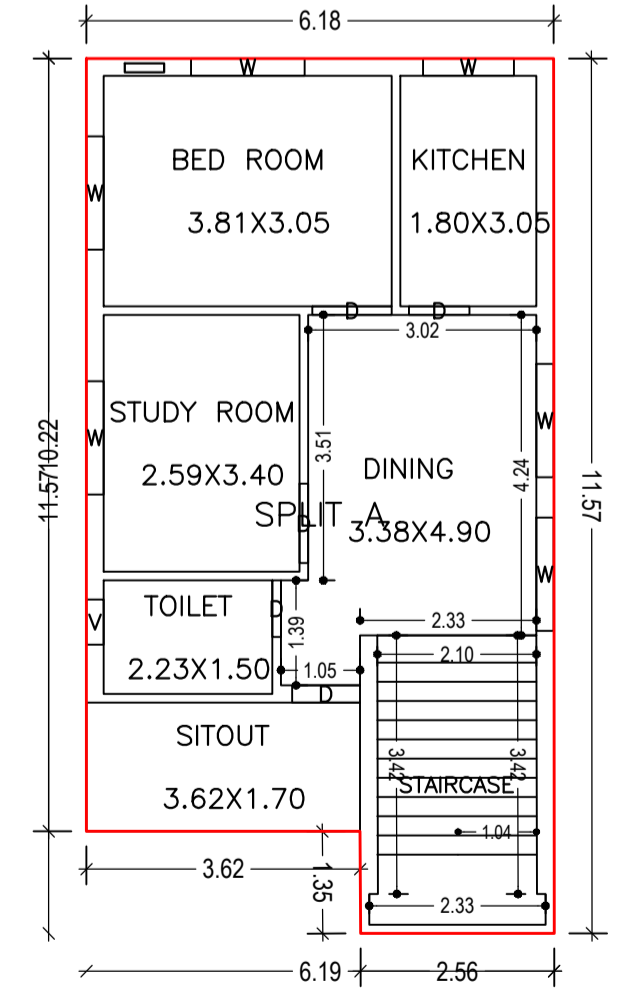
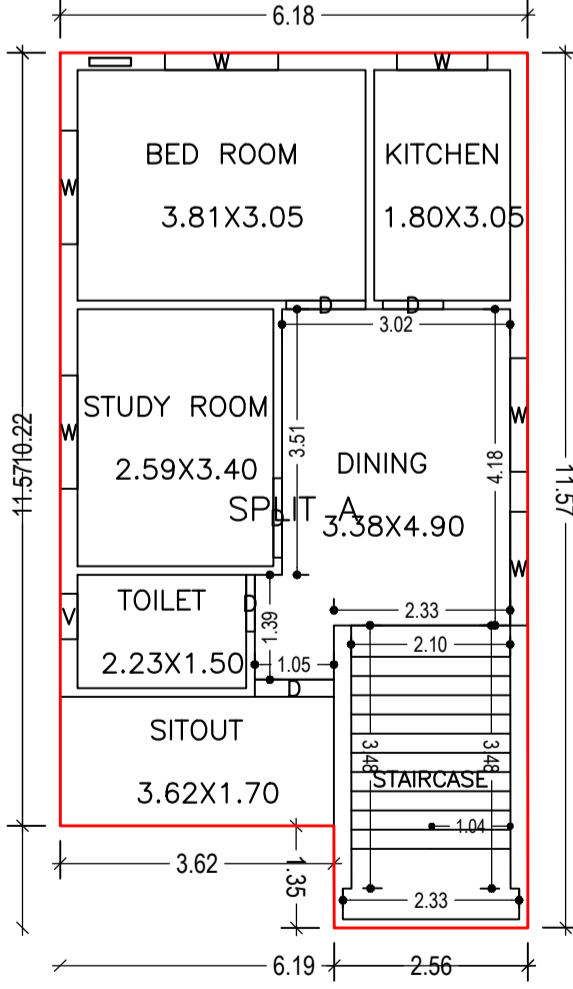

COLOR INDEX

PLOT BOUNDARY	Black
ABUTTING ROAD	Green
PROPOSED CONSTRUCTION	Red
COMMON PLOT	Yellow
ROAD WIDENING AREA	Blue
EXISTING (To be retained)	Light Blue
EXISTING (To be demolished)	Dark Blue

Buildingwise Floor FAR Details

Floor Name	Building Name A (A)		Total	
	Proposed Built Up Area (Sq.mt.)	Proposed FAR Area (Sq.mt.)	Total Proposed Built Up Area (Sq.mt.)	Total FAR Area (Sq.mt.)
Ground Floor	66.66	66.66	66.66	66.66
First Floor	66.66	66.66	66.66	66.66
Terrace Floor	0.00	0.00	0.00	0.00
Total	133.32	133.32	133.32	133.32

FAR & Tenement Details (Table 4c-1)

Building	No. of Same Bldg	Total Built Up Area (Sq.mt.)	Proposed FAR Area (Sq.mt.) Resi.	Total FAR Area (Sq.mt.)	Total Consumed Additional FAR Area (Sq.mt.)	Tnmt (No.)
A (A)	1	133.32	133.32	133.32	133.32	01
Grand Total	1	133.32	133.32	133.32	133.32	01

UnitBUA Table for Building :A (A)

FLOOR	Name	UnitBUA Type	UnitBUA Area	Carpet Area	No. of Rooms	No. of Tenement
GROUND FLOOR PLAN	SPLIT A	FLAT	133.32	133.20	6	1
FIRST FLOOR PLAN	SPLIT A	FLAT	0.00	0.00	6	0
Total:	-	-	133.32	133.20	12	1

LTP NAME AND SIGNATURE SANJEEV KUMAR RAY DMC/ENG/0001/2019	STRUCTURAL ENG'S NAME AND SIGNATURE	BUILDER NAME AND SIGNATURE	DIGITAL SIGNATURE
--	-------------------------------------	----------------------------	-------------------