

Proposal Basic Information	
Proposal File No.	DMC/BP/0126/W23/2021
Owner Name	SMT JAYANTI DEVI
Khata No	NEW - 489 , OLD - 09
Plot No	NEW - 3723 , OLD - 2829 , 2830
Village Name	Kolakusma
Use	Residential
SubUse	Bungalow/ Dwelling / Non Apartment

AREA STATEMENT		VERSION NO.: 1.0.55
DHANBAD MUNICIPAL CORPORATION		VERSION DATE: 16/10/2020
PROJECT DETAIL:		
Region: JHARKHAND URBAN LOCAL BODIES	Plot Use: Residential	
District: DHANBAD	Plot SubUse: Bungalow/ Dwelling / Non Apartment	
Authority: DHANBAD MUNICIPAL CORPORATION	PlotNearbyReligiousStructure: NA	
Inward No: DMC/BP/0126/W23/2021	Plot/SubPlot No: NEW- 3723, OLD - 2829, 2830	
Application Type: General Proposal	North: Road Width - 6.55 M WIDE ROAD	
Project Type: Building Permission	South: Plot No. - PART OF THIS PLOT	
Nature of Development: New	East: Plot No. - PART OF THIS PLOT	
Location of Development Area: Old Area	West: Plot No. - VENDOR'S NIZ	
AREA DETAILS:		
AREA OF PLOT (Minimum)	(A)	SQ.MT. 199.09
NET AREA OF PLOT(Gross Plot Area - Deduction from Gross Plot area)	(A-Deductions)	199.09
Deduction for Balance Plot Area(from Gross Plot Area)		
Common Plot		14.63
Total		14.63
BALANCE AREA OF PLOT(Net Plot Area - Recreational/Amenity space)	(A-Deductions)	184.46
PLOT AREA FOR COVERAGE(Net Plot Area)	(A-Deductions)	199.09
Plot Area for FAR (Net Plot Area + Road Widening Area)	(A-Deductions)	199.09
COVERAGE CHECK		
Permissible Coverage area (70.00 %)		139.36
Proposed Coverage Area (58.74 %)		116.94
Total Prop. Coverage Area (58.74 %)		116.94
Balance coverage area (11.26 %)		22.42
FAR CHECK		
Perm. FAR Area (1.80)		358.36
Total Perm. FAR area		358.36
Residential FAR		240.69
Proposed FAR Area		240.69
Total Proposed FAR Area		240.69
Consumed FAR (Factor)		1.21
Balance FAR Area		117.67
BUILT UP AREA CHECK		
Total Proposed BuiltUp Area		240.69
ARCHITECT (Regd)		AMARENDRA KUMAR
ENGINEER (Regd)		
SUPERVISOR (Regd)		
OWNER (Regd)		SMT JAYANTI DEVI
DEVELOPMENT AUTHORITY		LOCAL BODY

COLOR INDEX	
PLOT BOUNDARY	Black
ABUTTING ROAD	Green
PROPOSED CONSTRUCTION	Red
COMMON PLOT	Yellow
ROAD WIDENING AREA	Blue
EXISTING (To be retained)	Orange
EXISTING (To be demolished)	Grey

Buildingwise Floor FAR Details				
Floor Name	Building Name AA (BB)		Total	
	Proposed Built Up Area (Sq.mt.)	Proposed FAR Area (Sq.mt.)	Total Proposed Built Up Area (Sq.mt.)	Total FAR Area (Sq.mt.)
Ground Floor	116.94	116.94	116.94	116.94
First Floor	123.75	123.75	123.75	123.75
Terrace Floor	0.00	0.00	0.00	0.00
Total :	240.69	240.69	240.69	240.69

Building USE/SUBUSE Details			
Building Name	Building Use	Building SubUse	Building Structure
AA (BB)	Residential	Bungalow/ Dwelling / Non Apartment	Non-Highrise

FAR & Tenement Details (Table 4c-1)						
Building	No. of Same Bldg	Total Built Up Area (Sq.mt.)	Proposed FAR Area (Sq.mt.)	Total FAR Area (Sq.mt.)	Total Consumed Additional FAR Area (Sq.mt.)	Trmt (No.)
AA (BB)	1	240.69	240.69	240.69	240.69	01
Grand Total :	1	240.69	240.69	240.69	240.69	01

UnitBUA Table for Building :AA (BB)						
FLOOR	Name	UnitBUA Type	UnitBUA Area	Carpet Area	No. of Rooms	No. of Tenement
GROUND FLOOR	SPLIT AA	FLAT	240.69	240.32	10	1
FIRST FLOOR	SPLIT AA	FLAT	0.00	0.00	11	0
Total:	-	-	240.69	240.32	21	1

SCHEDULE OF DOOR:

BUILDING NAME	NAME	LENGTH	HEIGHT	NOS
AA (BB)	D	0.76	2.10	10
AA (BB)	D	0.91	2.10	02
AA (BB)	D	1.07	2.10	07
AA (BB)	D	1.08	2.10	01

SCHEDULE OF WINDOW/VENTILATION:

BUILDING NAME	NAME	LENGTH	HEIGHT	NOS
AA (BB)	w	0.61	1.20	06
AA (BB)	w	0.91	1.20	03
AA (BB)	w	1.22	1.20	02
AA (BB)	w	1.52	1.20	11

Building :AA (BB)

Floor Name	Total Built Up Area (Sq.mt.)	Proposed FAR Area (Sq.mt.)	Total FAR Area (Sq.mt.)	Total Consumed Additional FAR Area (Sq.mt.)	Trmt (No.)
Ground Floor	116.94	116.94	116.94	116.94	01
First Floor	123.75	123.75	123.75	123.75	00
Terrace Floor	0.00	0.00	0.00	0.00	00
Total :	240.69	240.69	240.69	240.69	01
Total Number of Same Buildings	1				
Total :	240.69	240.69	240.69	240.69	01

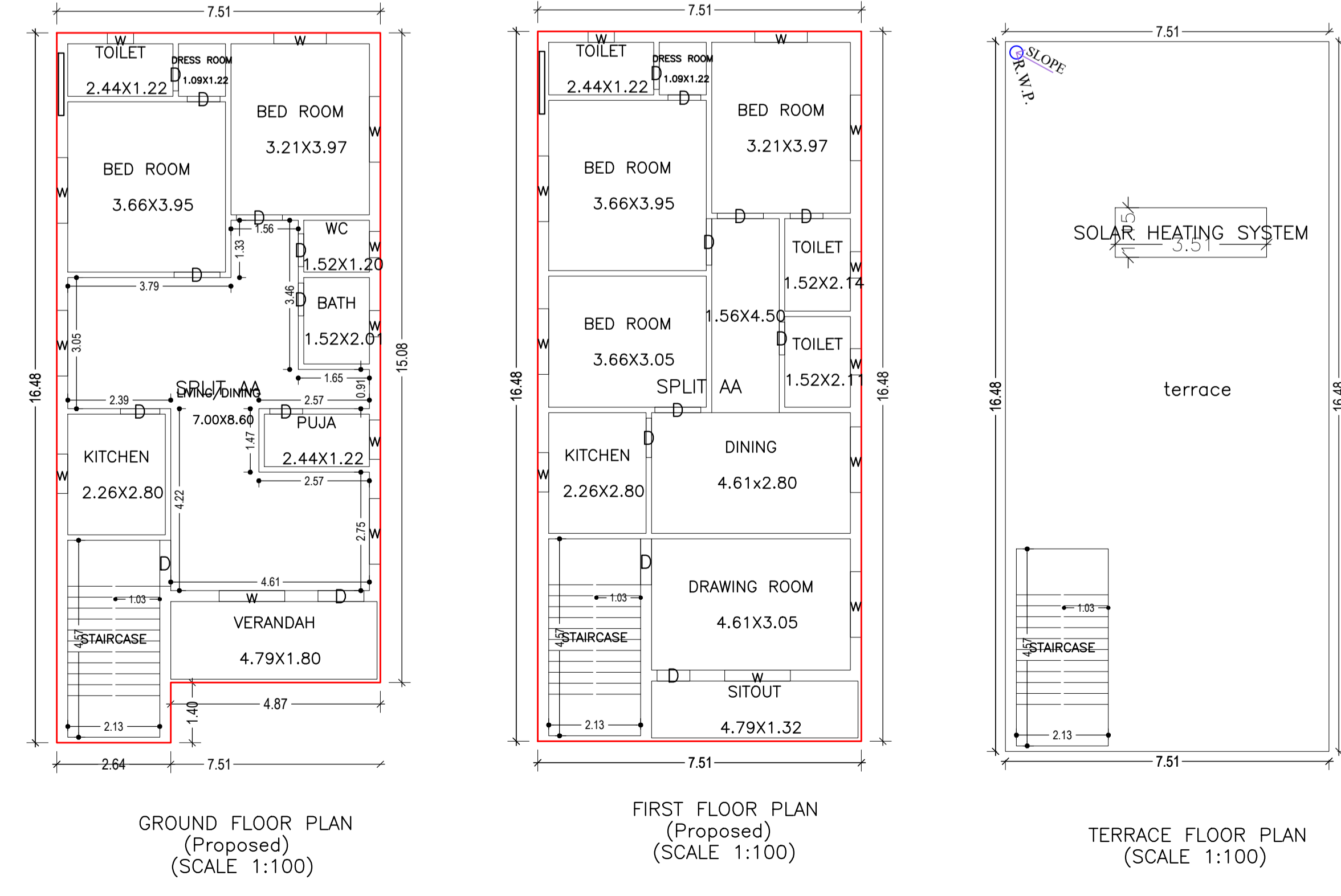

LTP NAME AND SIGNATURE	STRUCTURAL ENG'S NAME AND SIGNATURE	BUILDER NAME AND SIGNATURE	DIGITAL SIGNATURE
AMARENDRA KUMAR DMC/ENG/0009/2016			

Proposal Basic Information	
Proposal File No.	DMC/BP/0126/W23/2021
Owner Name	SMT JAYANTI DEVI
Khata No	NEW - 489 , OLD - 09
Plot No	NEW - 3723 , OLD - 2829 , 2830
Village Name	Kolakusma
Use	Residential
SubUse	Bungalow/ Dwelling / Non Apartment

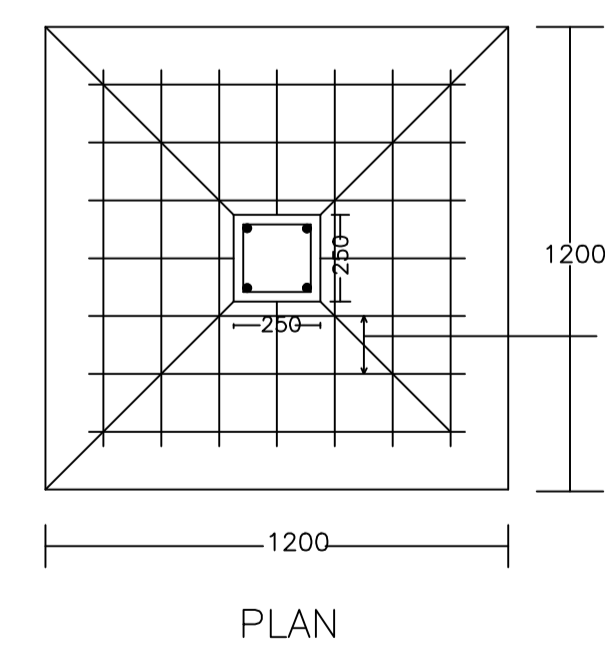
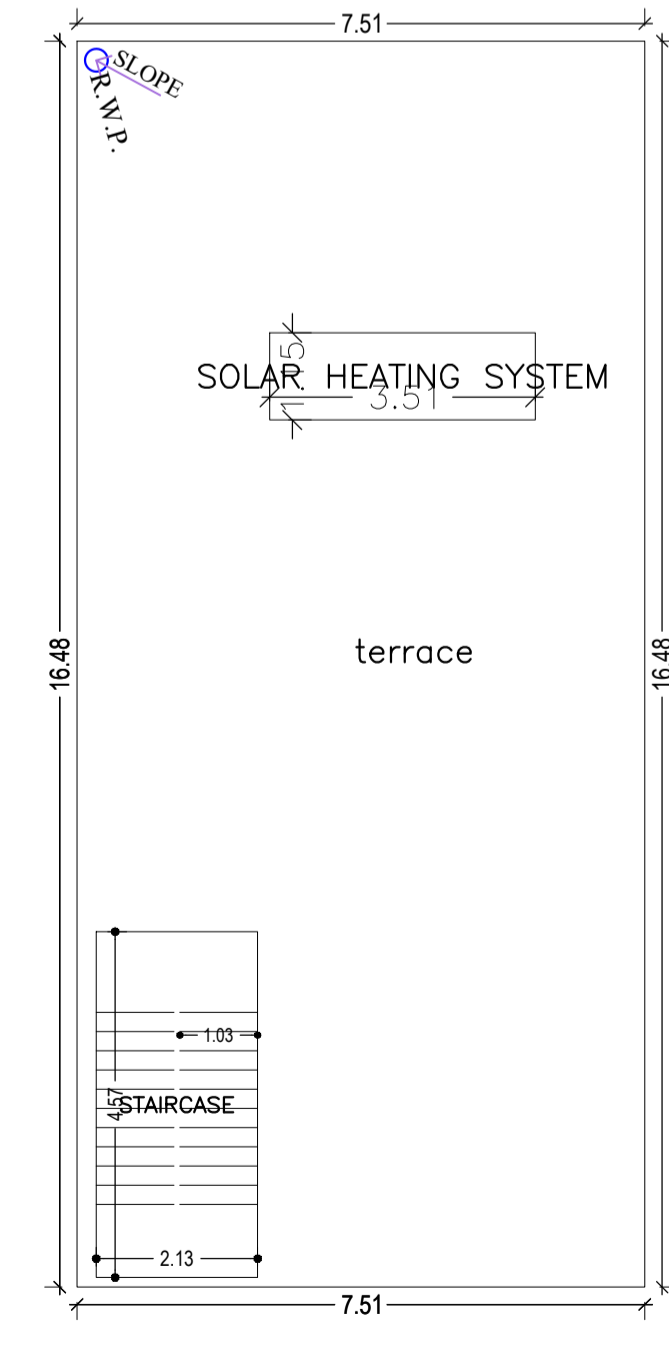
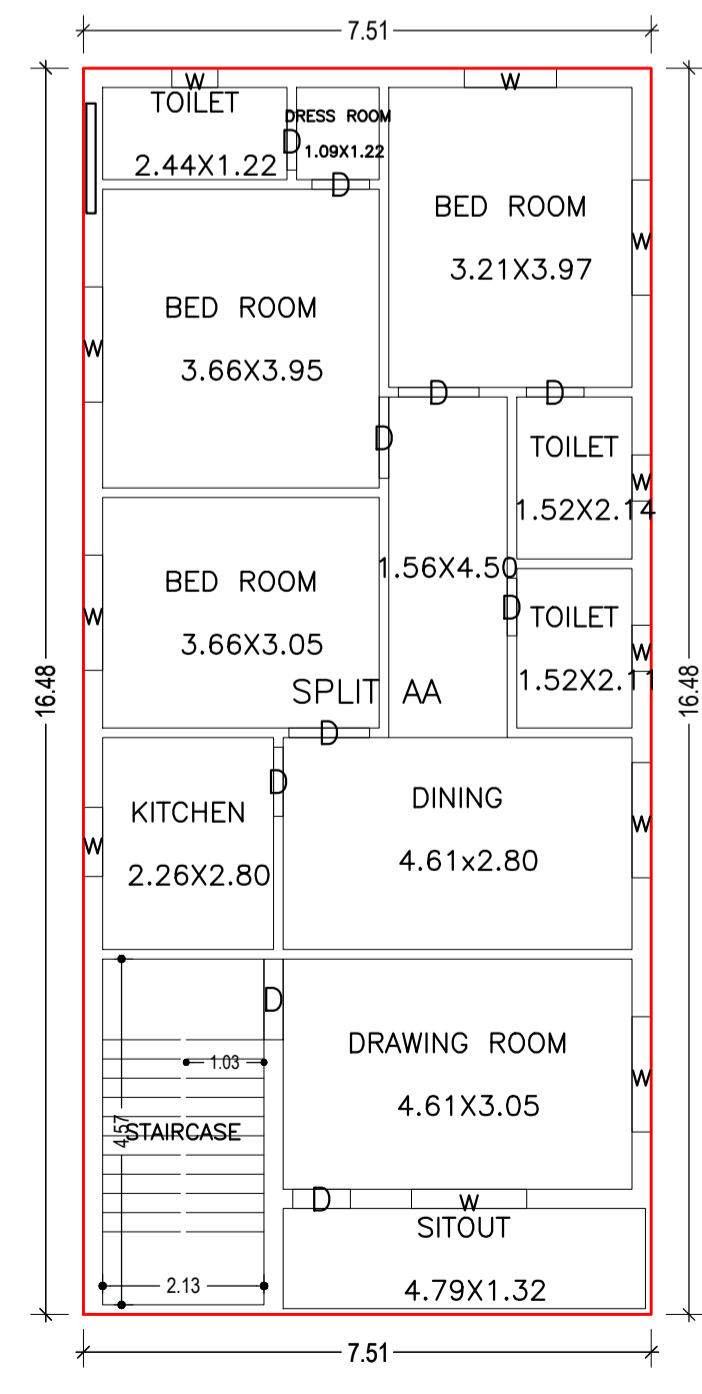
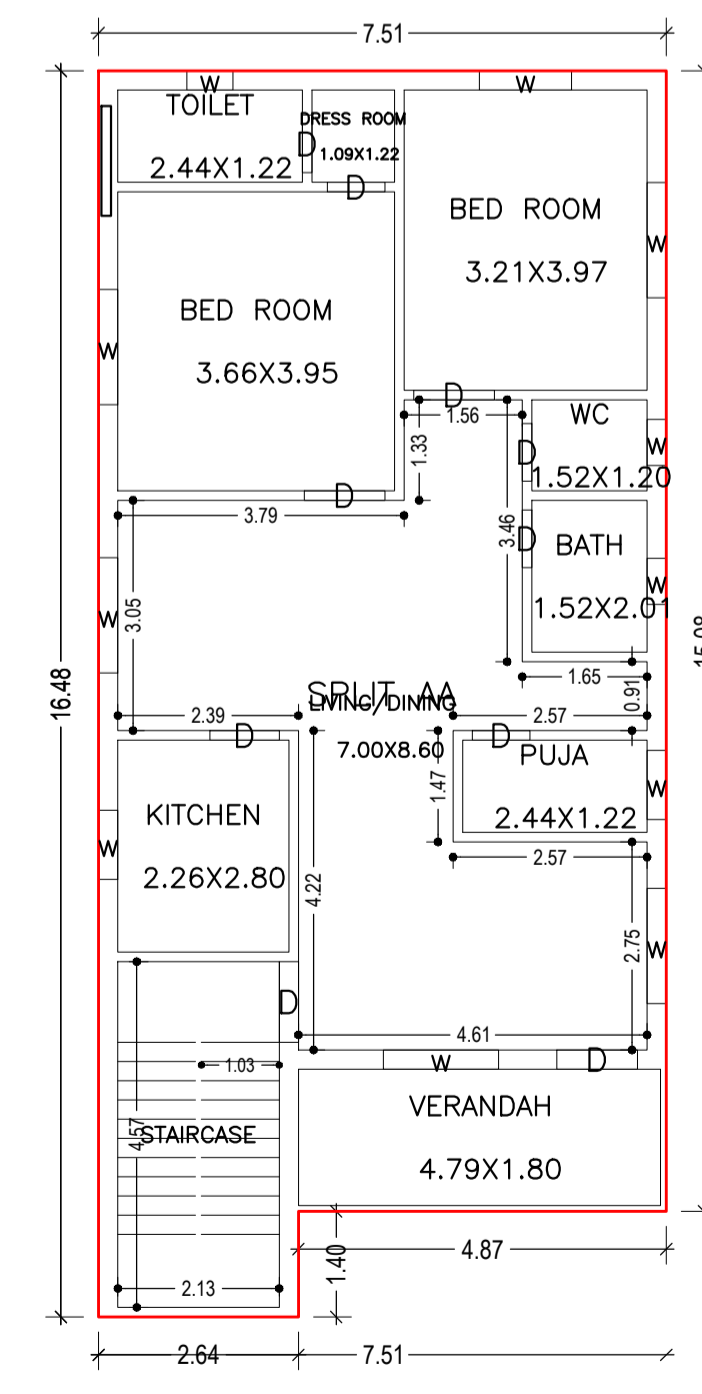
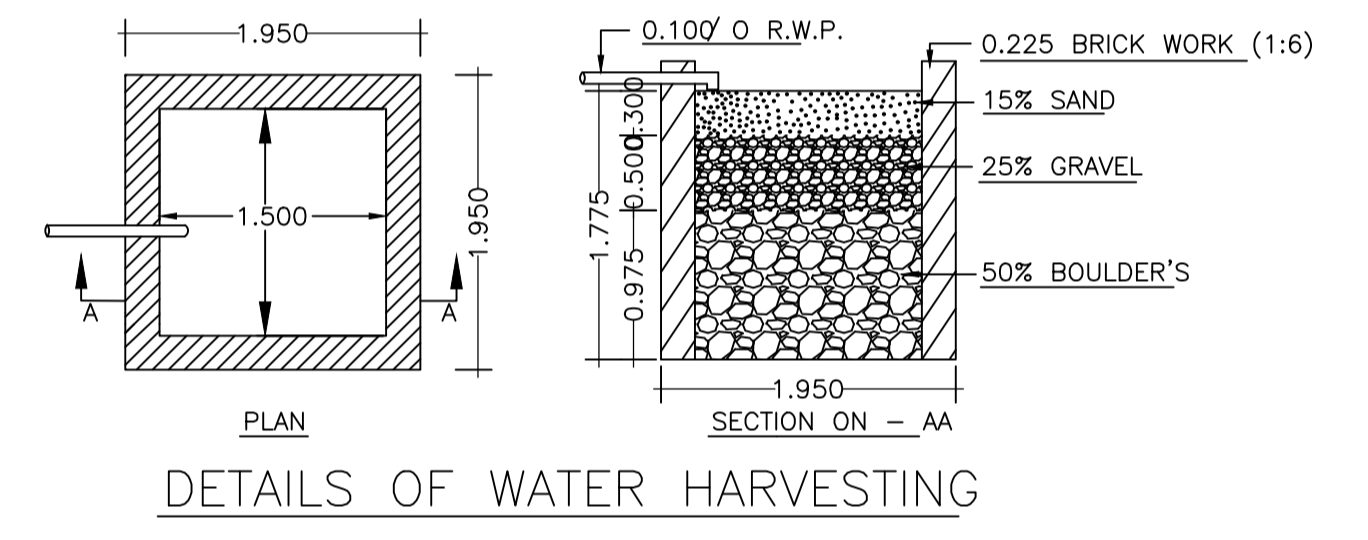
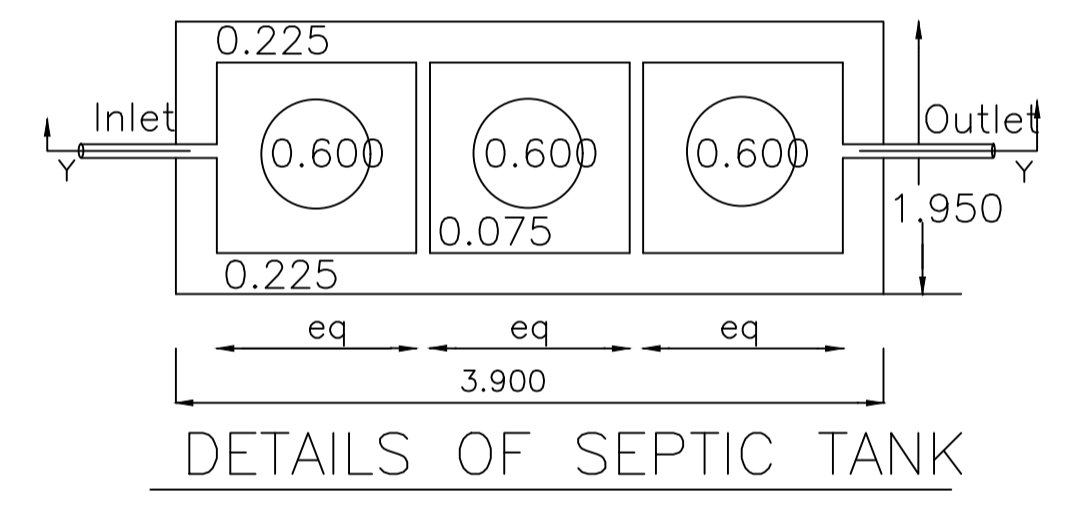
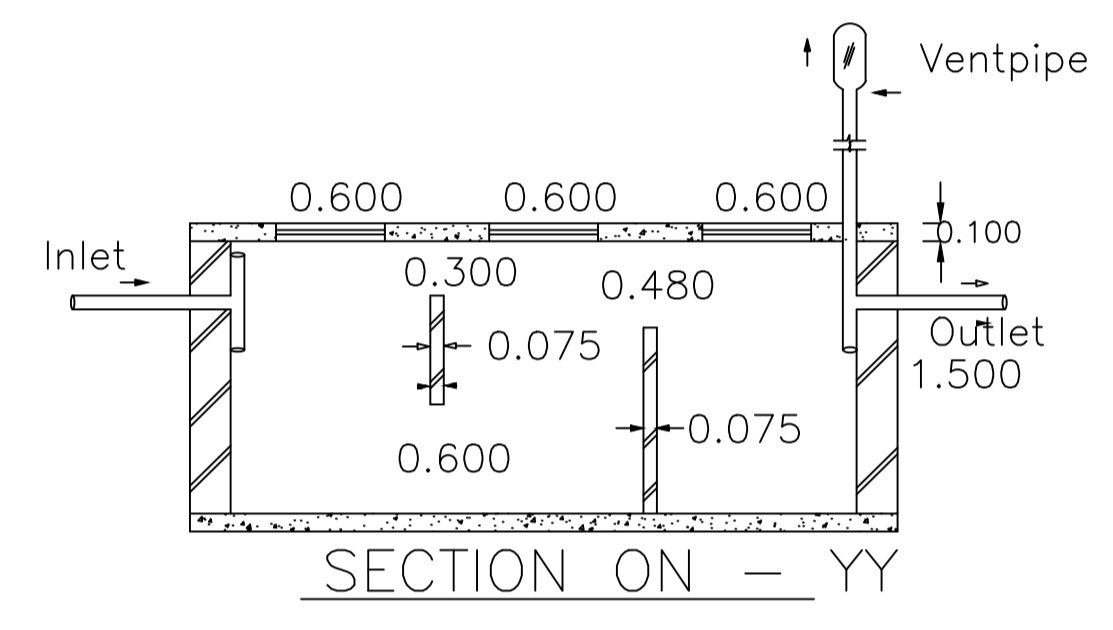
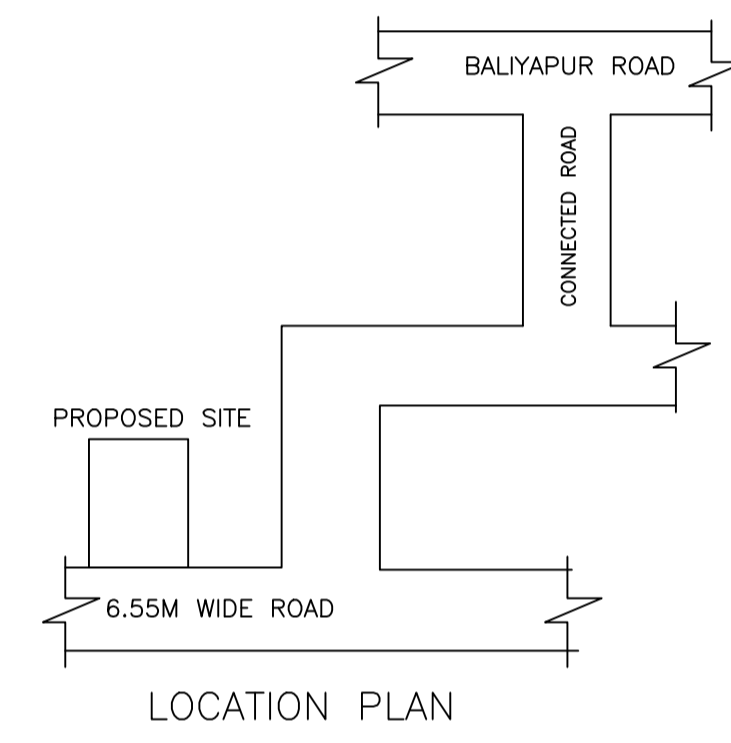
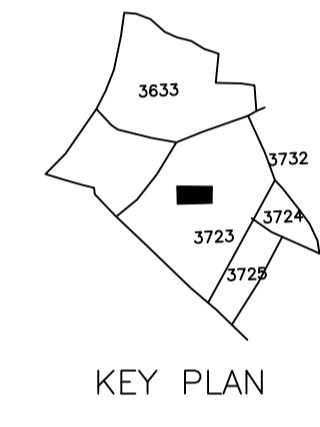
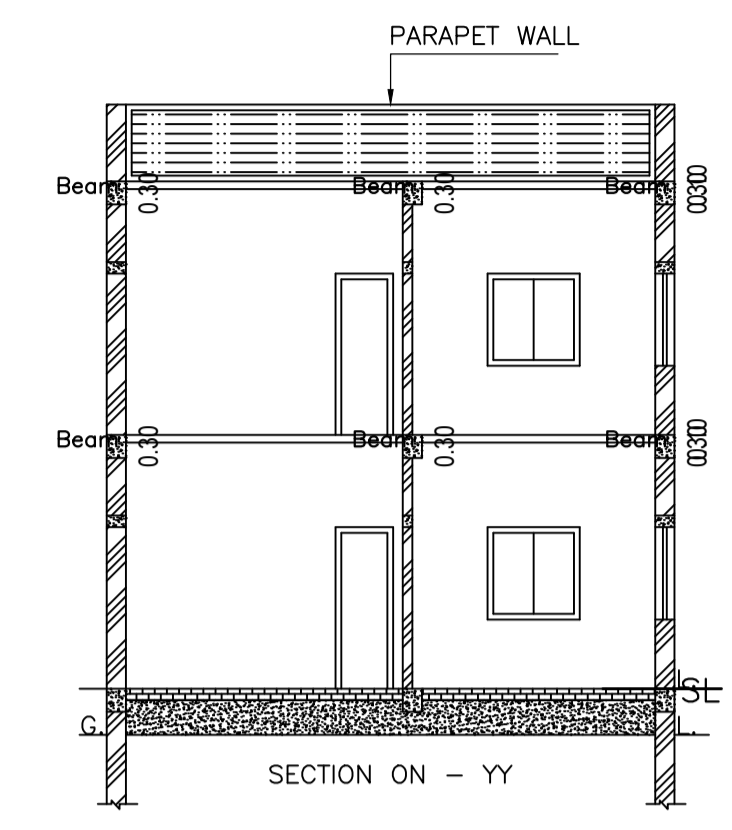
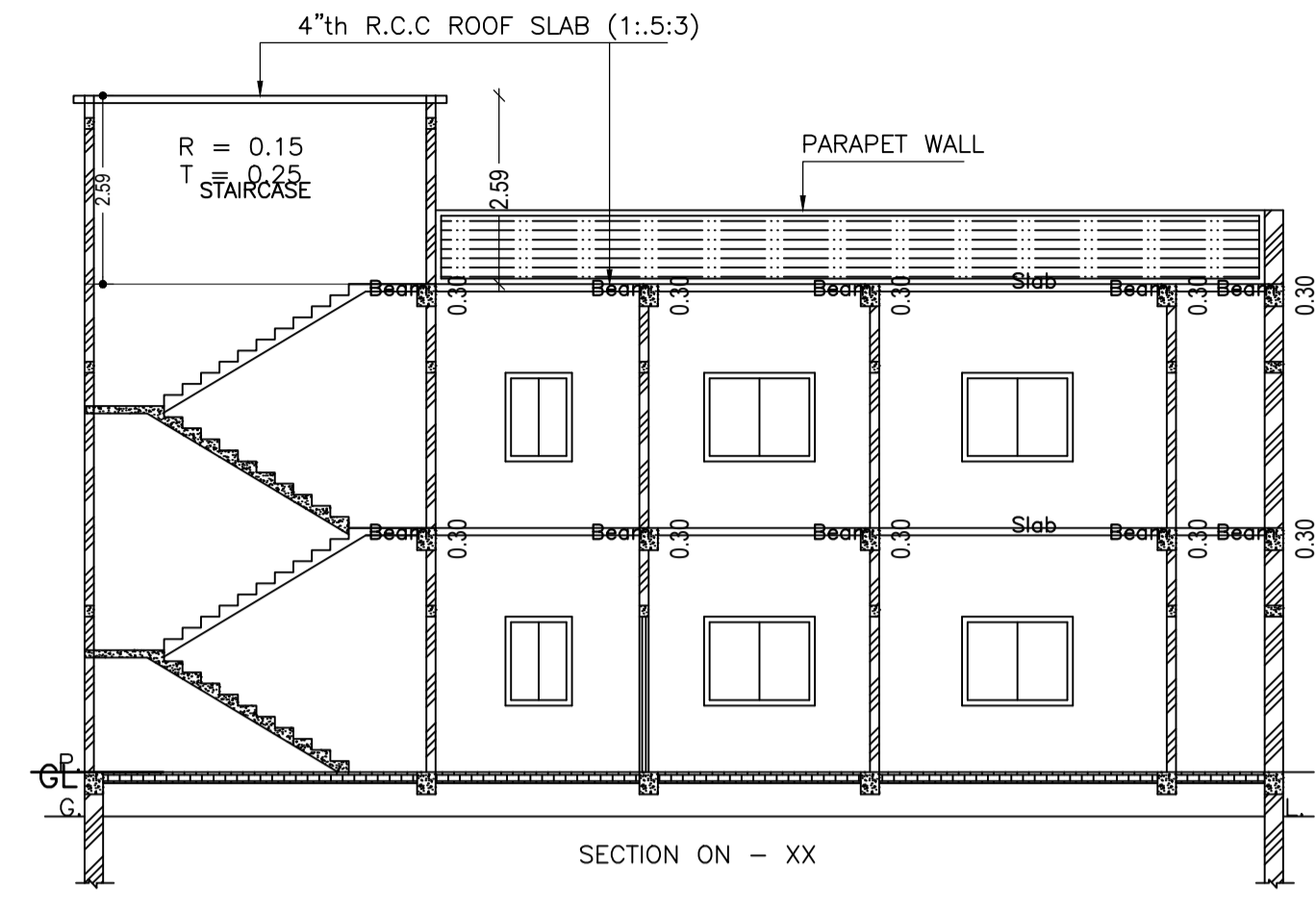
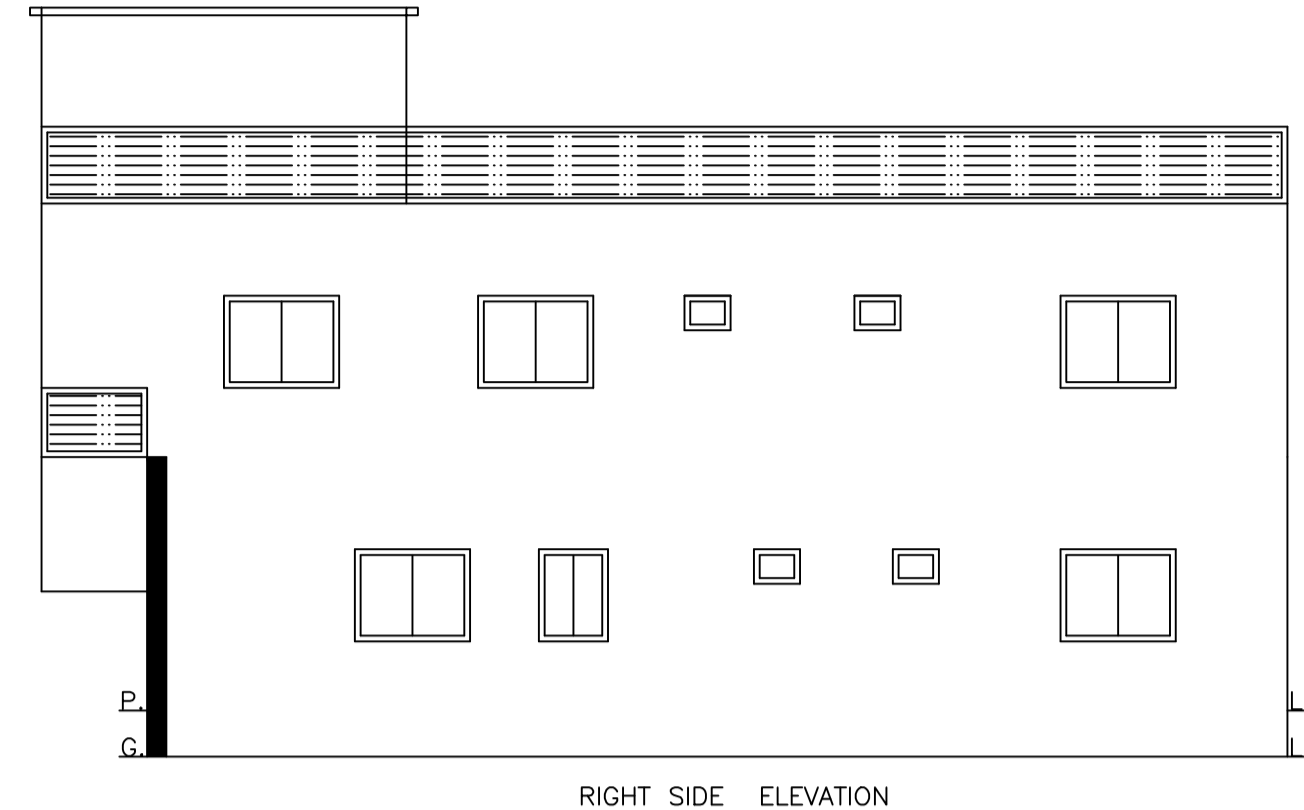
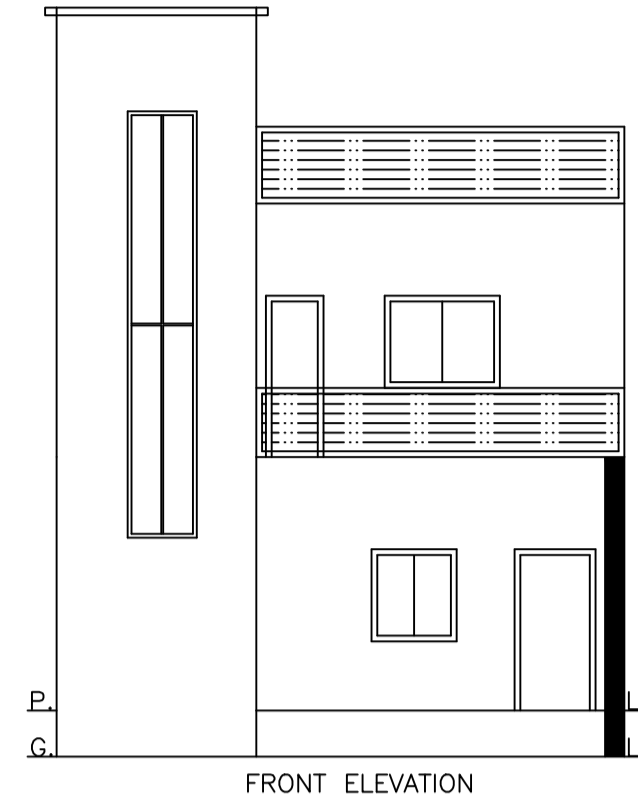

DETAIL OF COLUMNS

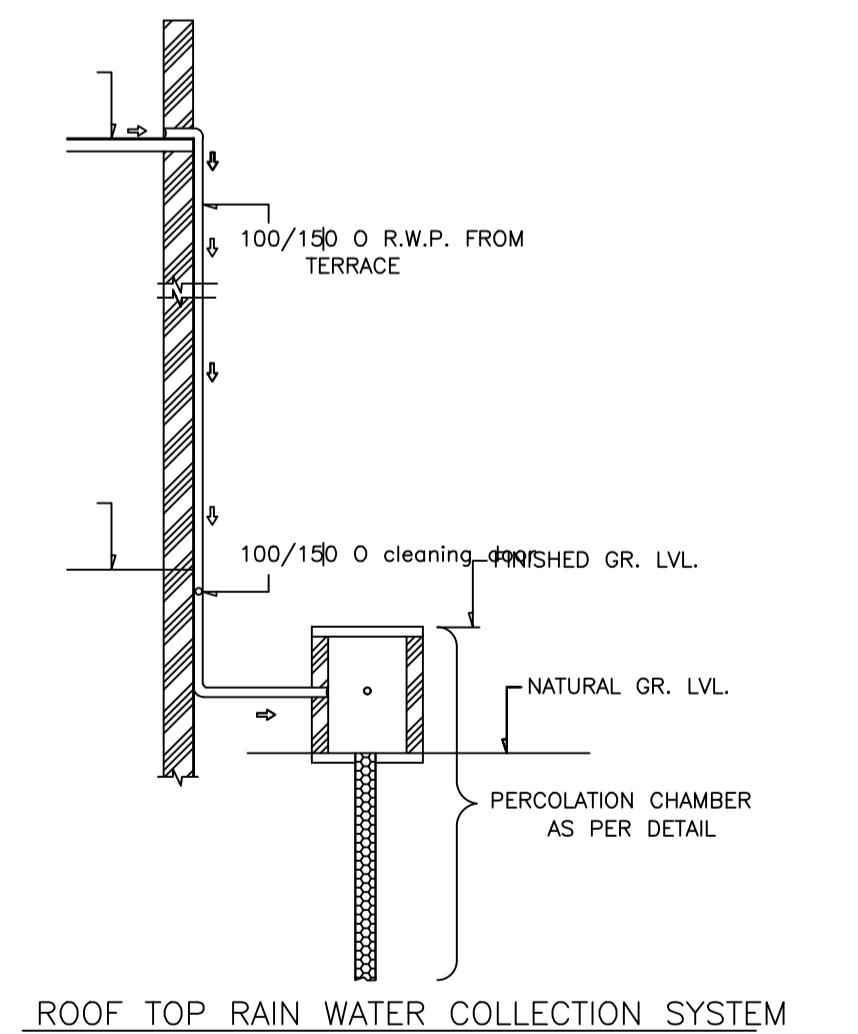
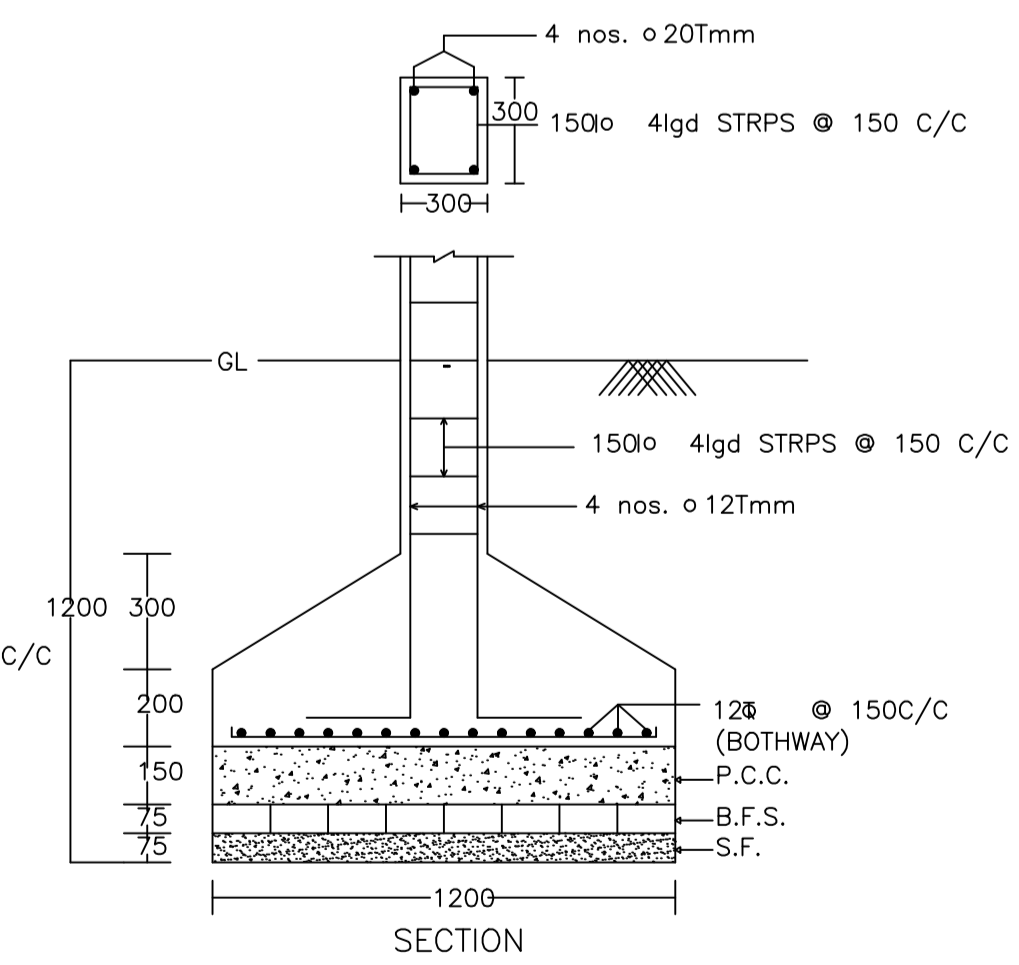

LTP NAME AND SIGNATURE	STRUCTURAL ENG'S NAME AND SIGNATURE	BUILDER NAME AND SIGNATURE	DIGITAL SIGNATURE
AMARENDRA KUMAR DMC/ENG/0009/2016			