

SCHEDULE OF DOOR:

| BUILDING NAME | NAME | LENGTH | HEIGHT | NOS |
|---------------|------|--------|--------|-----|
| AA (BB) | D | 0.76 | 2.10 | 01 |
| AA (BB) | D | 0.91 | 2.10 | 02 |
| AA (BB) | D | 1.06 | 2.10 | 01 |
| AA (BB) | D | 1.07 | 2.10 | 04 |

SCHEDULE OF WINDOW/VENTILATION:

| BUILDING NAME | NAME | LENGTH | HEIGHT | NOS |
|---------------|------|--------|--------|-----|
| AA (BB) | W | 0.61 | 1.20 | 02 |
| AA (BB) | W | 0.91 | 1.20 | 05 |
| AA (BB) | W | 1.22 | 1.20 | 05 |

UnitBUA Table for Building :AA (BB)

| FLOOR | Name | UnitBUA Type | UnitBUA Area | Carpet Area | No. of Rooms | No. of Tenement |
|-------------------|----------|--------------|--------------|-------------|--------------|-----------------|
| GROUND FLOOR PLAN | SPLIT AB | FLAT | 118.25 | 118.06 | 8 | 1 |
| Total: | - | - | 118.25 | 118.06 | 8 | 1 |

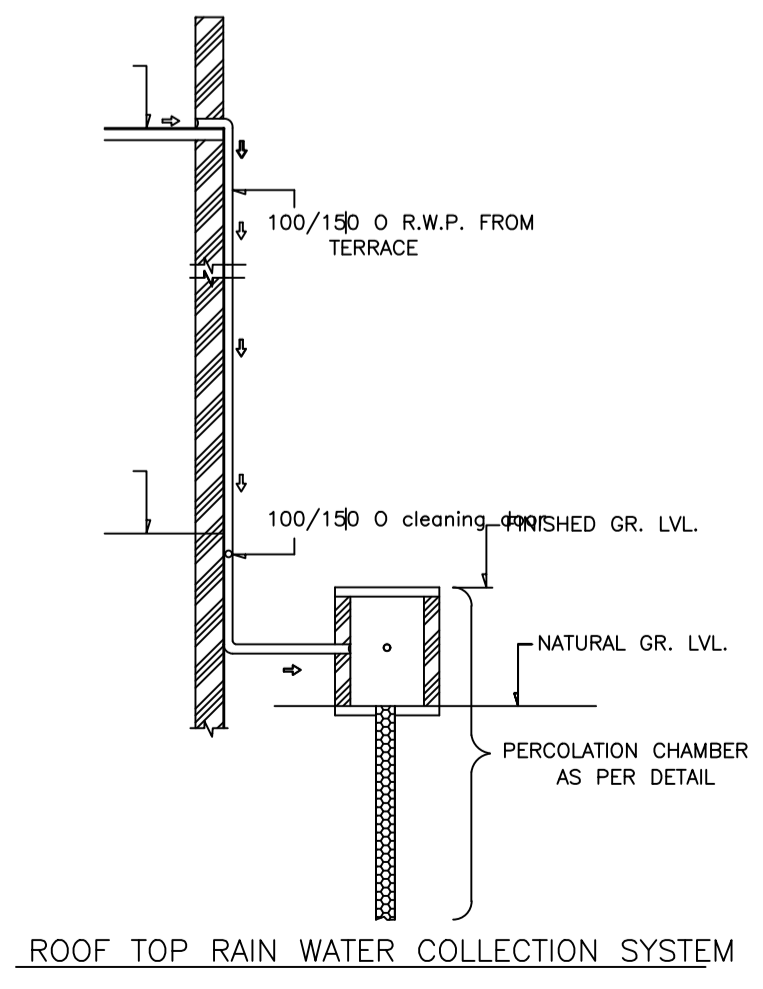
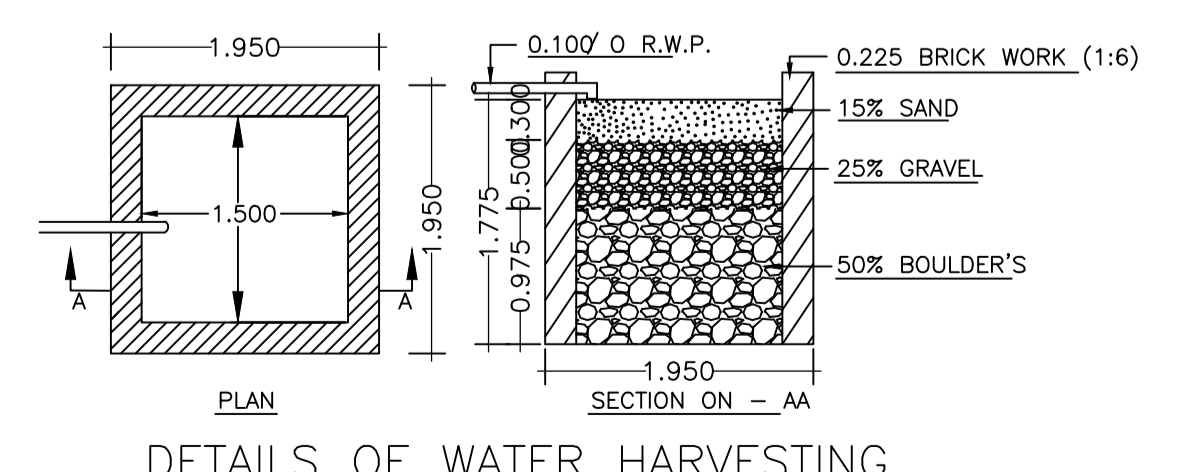

Proposal Basic Information

| | |
|-------------------|------------------------------------|
| Proposal File No. | DMC/BP/0354/W20/2021 |
| Owner Name | SRI MAHIPAL PARAMANIK |
| Khata No | NEW - 220 , OLD - 29 |
| Plot No | NEW - 133 , OLD - 105 |
| Village Name | Baramuri |
| Use | Residential |
| SubUse | Bungalow/ Dwelling / Non Apartment |

| AREA STATEMENT | | VERSION NO. : 1.0.61 |
|--|---|--------------------------|
| DHANBAD MUNICIPAL CORPORATION | | VERSION DATE: 16/10/2020 |
| PROJECT DETAIL: | | |
| Region: JHARKHAND URBAN | Plot Use: Residential | |
| LOCAL BODIES | Plot SubUse: Bungalow/ Dwelling / Non Apartment | |
| District: DHANBAD | PlotNearbyReligiousStructure: NA | |
| Authority: DHANBAD MUNICIPAL CORPORATION | | |
| Inward No: DMC/BP/0354/W20/2021 | Plot/SubPlot No: NEW - 133 , OLD - 105 | |
| Application Type: General Proposal | North: Plot No. - SURVEY PLOT NO.5 (C.O) | |
| Project Type: Building Permission | South: Road Width - 4.26M WIDE ROAD | |
| Nature of Development: New | East: Plot No. - PLOT NO.G (C.O) | |
| Location of Development Area: Old Area | West: Plot No. - PLOT NO.E (C.O) | |
| AREA DETAILS: | | |
| AREA OF PLOT (Minimum) | (A) | SQ.MT. |
| NET AREA OF PLOT(Gross Plot Area - Deduction from Gross Plot area) | (A-Deductions) | 297.08 |
| Deduction for Balance Plot Area(from Gross Plot Area) | | |
| Common Plot | | 42.78 |
| Total | | 42.78 |
| BALANCE AREA OF PLOT(Net Plot Area - Recreational/Amenity space) | (A-Deductions) | 254.30 |
| PLOT AREA FOR COVERAGE(Net Plot Area) | (A-Deductions) | 297.08 |
| Plot Area for FAR (Net Plot Area + Road Widening Area) | (A-Deductions) | 297.08 |
| COVERAGE CHECK | | |
| Permissible Coverage area (60.00 %) | | 178.25 |
| Proposed Coverage Area (39.80 %) | | 118.25 |
| Total Prop. Coverage Area (39.8 %) | | 118.25 |
| Balance coverage area (20.20 %) | | 60.00 |
| FAR CHECK | | |
| Perm. FAR Area (1.50) | | 445.62 |
| Total Perm. FAR area | | 445.62 |
| Residential FAR | | 118.25 |
| Proposed FAR Area | | 118.25 |
| Total Proposed FAR Area | | 118.25 |
| Consumed FAR (Factor) | | 0.40 |
| Balance FAR Area | | 327.37 |
| BUILT UP AREA CHECK | | |
| Total Proposed BuiltUp Area | | 118.25 |
| ARCHITECT (Regd) | ABHISHEK KUMAR | |
| ENGINEER (Regd) | | |
| SUPERVISOR (Regd) | | |
| OWNER (Regd) | SRI MAHIPAL PARAMANIK | |
| DEVELOPMENT AUTHORITY | | |
| LOCAL BODY | | |

COLOR INDEX

| | |
|-----------------------------|------------|
| PLOT BOUNDARY | Black |
| ABUTTING ROAD | Green |
| PROPOSED CONSTRUCTION | Red |
| COMMON PLOT | Yellow |
| ROAD WIDENING AREA | Blue |
| EXISTING (To be retained) | Light Blue |
| EXISTING (To be demolished) | Dark Blue |

Buildingwise Floor FAR Details

| Floor Name | Building Name | | Total | |
|---------------|---------------------------------|----------------------------|---------------------------------------|-------------------------|
| | Proposed Built Up Area (Sq.mt.) | Proposed FAR Area (Sq.mt.) | Total Proposed Built Up Area (Sq.mt.) | Total FAR Area (Sq.mt.) |
| Ground Floor | 118.25 | 118.25 | 118.25 | 118.25 |
| Terrace Floor | 0.00 | 0.00 | 0.00 | 0.00 |
| Total : | 118.25 | 118.25 | 118.25 | 118.25 |

Building USE/SUBUSE Details

| Building Name | Building Use | Building SubUse | Building Structure |
|---------------|--------------|------------------------------------|--------------------|
| AA (BB) | Residential | Bungalow/ Dwelling / Non Apartment | Non-Highrise |

FAR & Tenement Details (Table 4c-1)

| Building | No. of Same Bldg | Total Built Up Area (Sq.mt.) | Proposed FAR Area (Sq.mt.) | Total FAR Area (Sq.mt.) | Total Consumed Additional FAR Area (Sq.mt.) | Trnmt (No.) |
|---------------|------------------|------------------------------|----------------------------|-------------------------|---|-------------|
| AA (BB) | 1 | 118.25 | 118.25 | 118.25 | 118.25 | 01 |
| Grand Total : | 1 | 118.25 | 118.25 | 118.25 | 118.25 | 01 |

| Floor Name | Total Built Up Area (Sq.mt.) | Proposed FAR Area (Sq.mt.) | | Total Consumed Additional FAR Area (Sq.mt.) | Trnmt (No.) |
|--------------------------------|------------------------------|----------------------------|-------------------------|---|-------------|
| | | Res. | Total FAR Area (Sq.mt.) | | |
| Ground Floor | 118.25 | 118.25 | 118.25 | 118.25 | 01 |
| Terrace Floor | 0.00 | 0.00 | 0.00 | 0.00 | 00 |
| Total : | 118.25 | 118.25 | 118.25 | 118.25 | 01 |
| Total Number of Same Buildings | 1 | | | | |
| Total : | 118.25 | 118.25 | 118.25 | 118.25 | 01 |

| LTP NAME AND SIGNATURE | STRUCTURAL ENG'S NAME AND SIGNATURE | BUILDER NAME AND SIGNATURE | DIGITAL SIGNATURE |
|--------------------------------------|-------------------------------------|----------------------------|-------------------|
| ABHISHEK KUMAR DMC/DFTM/0013/2020 | | | |

