

SECTION ON XX

SECTION ON YY

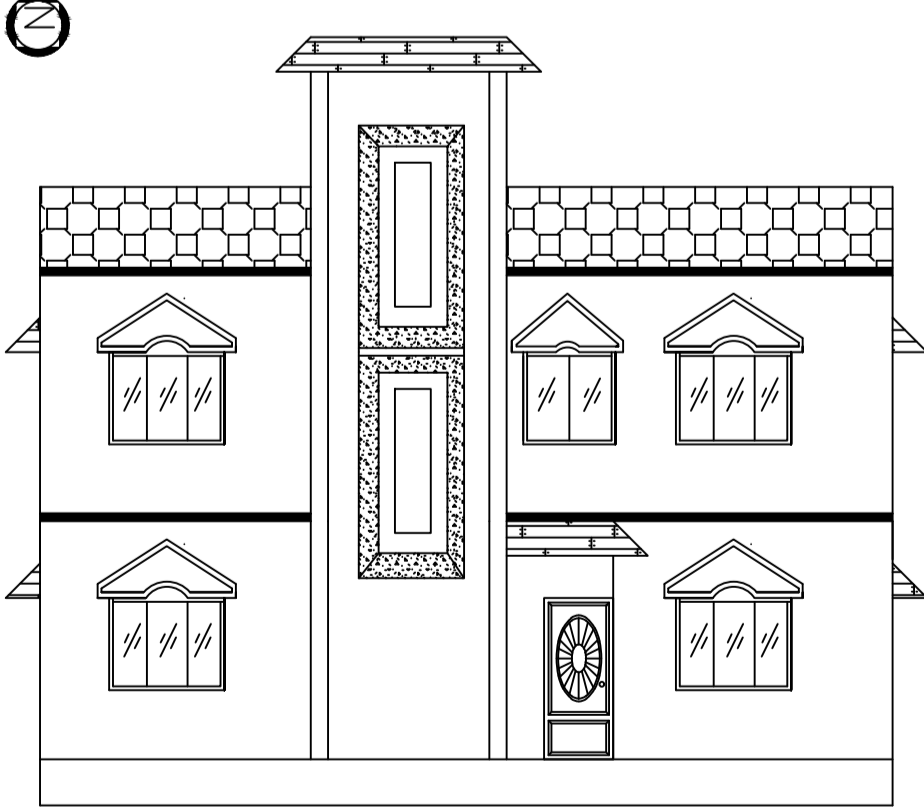
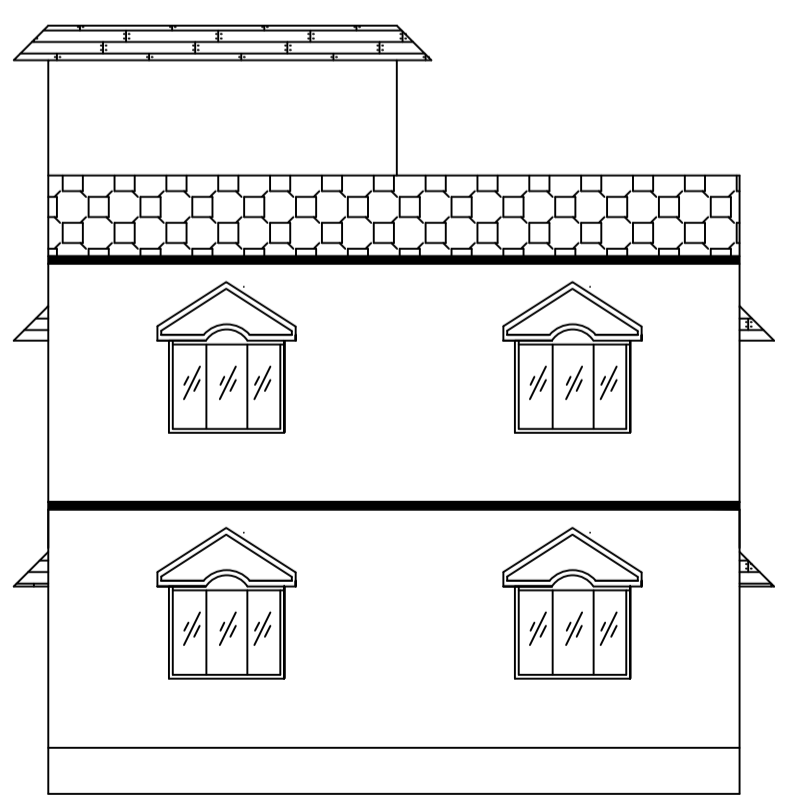

RIGHT SIDE ELEVATION

FRONT ELEVATION

Proposal Basic Information	
Proposal File No.	DMC/BP/0306/W26/2021
Owner Name	SUMANA CHAKRABORTY
Khata No.	02
Plot No.	2795(P)
Village Name	Hirapur
Use	Residential
SubUse	Bungalow/ Dwelling / Non Apartment

AREA STATEMENT		VERSION NO. : 1.0.61
DHANBAD MUNICIPAL CORPORATION		VERSION DATE: 16/10/2020
PROJECT DETAIL:		
Region: JHARKHAND URBAN LOCAL BODIES	Plot Use: Residential	
District: DHANBAD	Plot SubUse: Bungalow/ Dwelling / Non Apartment	
Authority: DHANBAD MUNICIPAL CORPORATION	PlotNearby/ReligiousStructure: NA	
Inward No: DMC/BP/0306/W26/2021	Plot/SubPlot No: 2795(P)	
Application Type: General Proposal	North: Plot No. - PART OF THIS PLOT, LOT NO. 3,1	
Project Type: Building Permission	South: Plot No. - PLOT NO. 2795, LOT NO. 5	
Nature of Development: New	East: Road Width - 4.57	
Location of Development Area: Old Area	West: Plot No. - PLOT NO. 2776	
AREA DETAILS:		
AREA OF PLOT (Minimum)	(A)	SQ.MT. 354.17
NET AREA OF PLOT(Gross Plot Area - Deduction from Gross Plot area)	(A-Deductions)	354.17
Deduction for Balance Plot Area(from Gross Plot Area)		
Common Plot		35.22
Total		35.22
BALANCE AREA OF PLOT(Net Plot Area - Recreational/Amenity space)	(A-Deductions)	318.95
PLOT AREA FOR COVERAGE(Net Plot Area)	(A-Deductions)	354.17
Plot Area for FAR (Net Plot Area + RoadWidening Area)	(A-Deductions)	354.17
COVERAGE CHECK		
Permissible Coverage area ( 60.00 % )		212.50
Proposed Coverage Area ( 29.12 % )		103.12
Total Prop. Coverage Area ( 29.12 % )		103.12
Balance coverage area ( 30.88 % )		109.38
FAR CHECK		
Perm. FAR Area ( 1.50 )		531.26
Total Perm. FAR area		531.26
Residential FAR		206.24
Proposed FAR Area		206.24
Total Proposed FAR Area		206.24
Consumed FAR (Factor)		0.58
Balance FAR Area		325.02
BUILT UP AREA CHECK		
Total Proposed BuiltUp Area		206.24
ARCHITECT (Regd)	Santosh	
ENGINEER (Regd)		
SUPERVISOR (Regd)		
OWNER (Regd)	SUMANA CHAKRABORTY	
DEVELOPMENT AUTHORITY		LOCAL BODY

COLOR INDEX	
PLOT BOUNDARY	Black
ABUTTING ROAD	Green
PROPOSED CONSTRUCTION	Red
COMMON PLOT	Yellow
ROAD WIDENING AREA	Blue
EXISTING (To be retained)	Light Blue
EXISTING (To be demolished)	Light Yellow

Building :A (A)					
Floor Name	Total Built Up Area (Sq.mt.)	Proposed FAR Area (Sq.mt.) Resi.	Total FAR Area (Sq.mt.)	Total Consumed Additional FAR Area (Sq.mt.)	Trmt (No.)
Ground Floor	103.12	103.12	103.12	103.12	01
First Floor	103.12	103.12	103.12	103.12	00
Terrace Floor	0.00	0.00	0.00	0.00	00
Total :	206.24	206.24	206.24	206.24	01
Total Number of Same Buildings :	1				
Total :	206.24	206.24	206.24	206.24	01

SCHEDULE OF DOOR:				
BUILDING NAME	NAME	LENGTH	HEIGHT	NOS
A (A)	D	0.72	2.10	02
A (A)	D	0.76	2.10	02
A (A)	D	0.84	2.10	02
A (A)	D	1.07	2.10	02
A (A)	D	1.14	2.10	06
A (A)	D	1.41	2.10	01

SCHEDULE OF WINDOW/VENTILATION:				
BUILDING NAME	NAME	LENGTH	HEIGHT	NOS
A (A)	V	0.61	1.20	04
A (A)	W	1.22	1.20	02
A (A)	W	1.41	1.20	01
A (A)	W	1.45	1.20	02
A (A)	W	1.83	1.20	12

UnitBUA Table for Building :A (A)						
FLOOR	Name	UnitBUA Type	UnitBUA Area	Carpet Area	No. of Rooms	No. of Tenement
GROUND FLOOR PLAN	SPLIT A	FLAT	206.24	206.21	8	1
FIRST FLOOR PLAN	SPLIT A	FLAT	0.00	0.00	8	0
Total:	-	-	206.24	206.21	16	1

Floor Name	Building Name A (A)		Total	
	Proposed Built Up Area (Sq.mt.)	Proposed FAR Area (Sq.mt.)	Total Proposed Built Up Area (Sq.mt.)	Total FAR Area (Sq.mt.)
Ground Floor	103.12	103.12	103.12	103.12
First Floor	103.12	103.12	103.12	103.12
Terrace Floor	0.00	0.00	0.00	0.00
Total :	206.24	206.24	206.24	206.24

Building USE/SUBUSE Details			
Building Name	Building Use	Building SubUse	Building Structure
A (A)	Residential	Residential Bldg/Apartment	Non-Highrise

FAR & Tenement Details (Table 4c-1)						
Building	No. of Same Bldg	Total Built Up Area (Sq.mt.)	Proposed FAR Area (Sq.mt.) Resi.	Total FAR Area (Sq.mt.)	Total Consumed Additional FAR Area (Sq.mt.)	Trmt (No.)
A (A)	1	206.24	206.24	206.24	206.24	01
Grand Total :	1	206.24	206.24	206.24	206.24	01

LTP NAME AND SIGNATURE	STRUCTURAL ENG'S NAME AND SIGNATURE	BUILDER NAME AND SIGNATURE	DIGITAL SIGNATURE
Santosh DMC/ENG/0019/2016			

Proposal Basic Information	
Proposal File No.	DMC/BP/0306/W26/2021
Owner Name	SUMANA CHAKRABORTY
Khata No	02
Plot No	2795(P)
Village Name	Hirapur
Use	Residential
SubUse	Bungalow/ Dwelling / Non Apartment

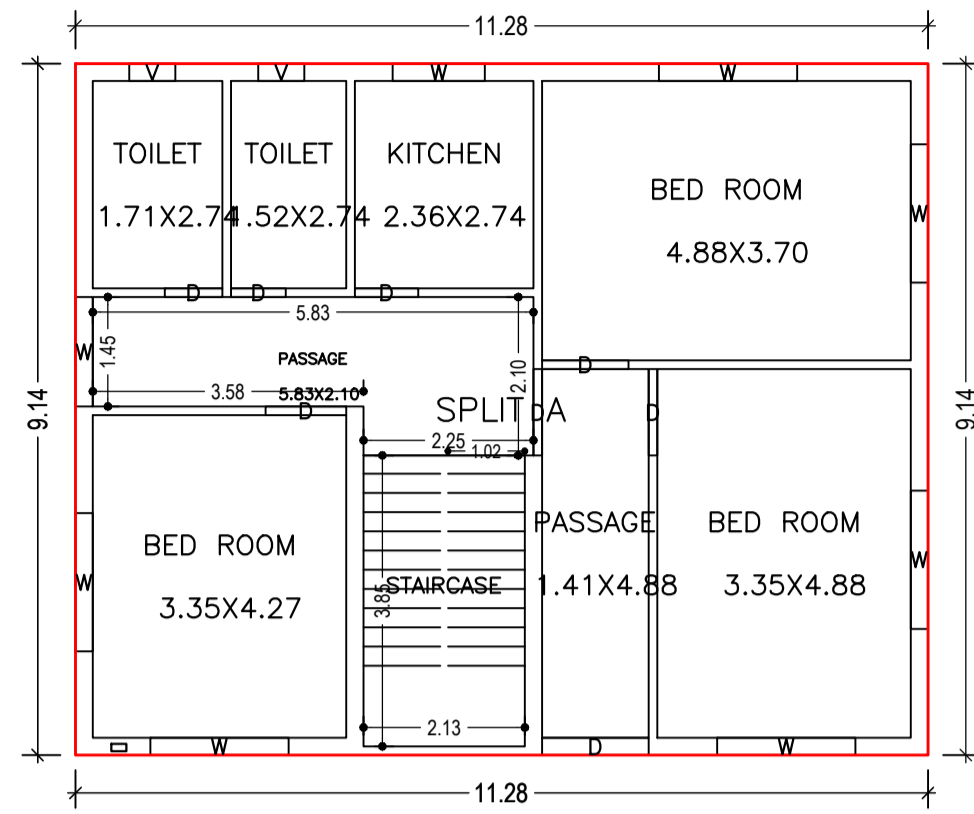

GROUND FLOOR PLAN  
(Proposed)  
(SCALE 1:100)

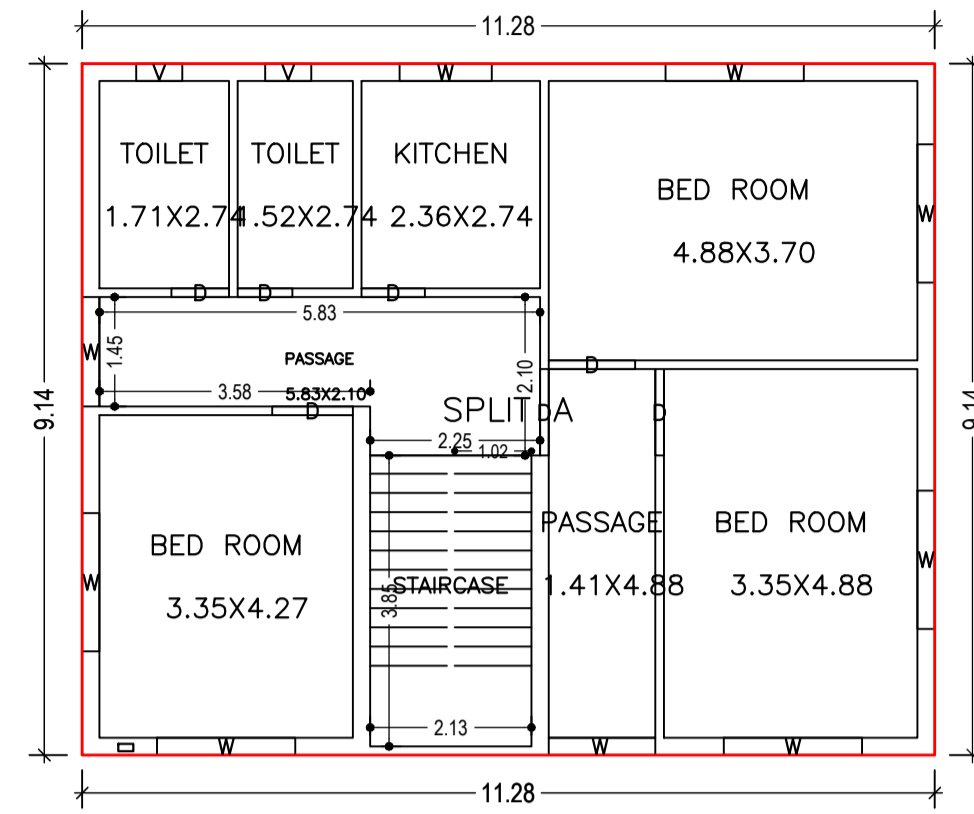

FIRST FLOOR PLAN  
(Proposed)  
(SCALE 1:100)

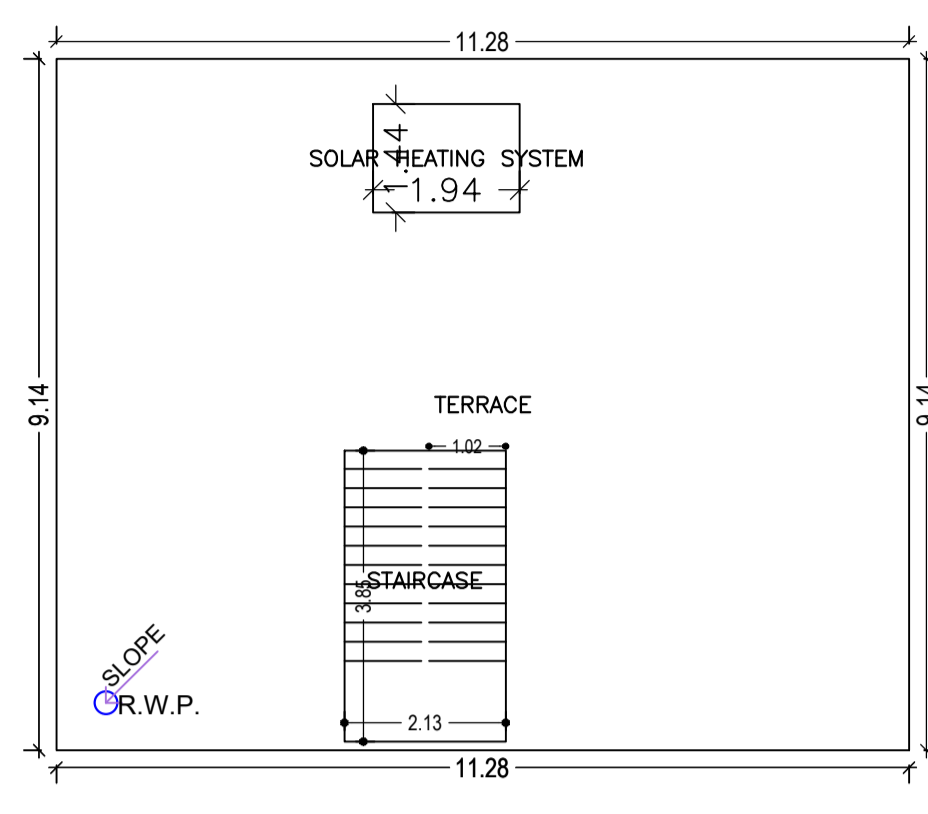

TERRACE FLOOR PLAN  
(SCALE 1:100)

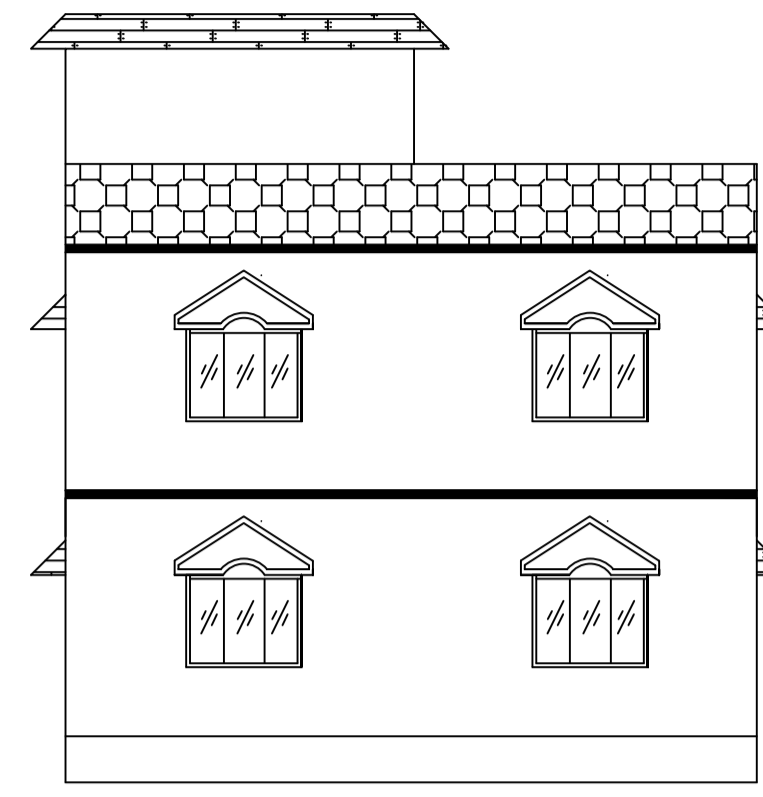

RIGHT SIDE ELEVATION

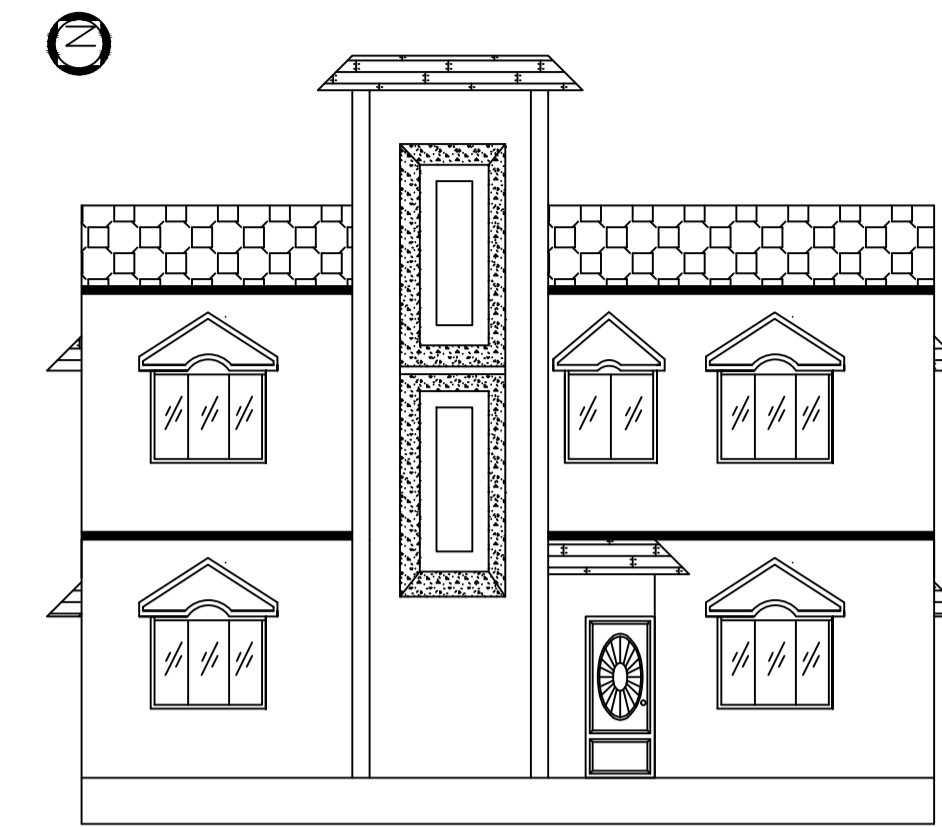

FRONT ELEVATION

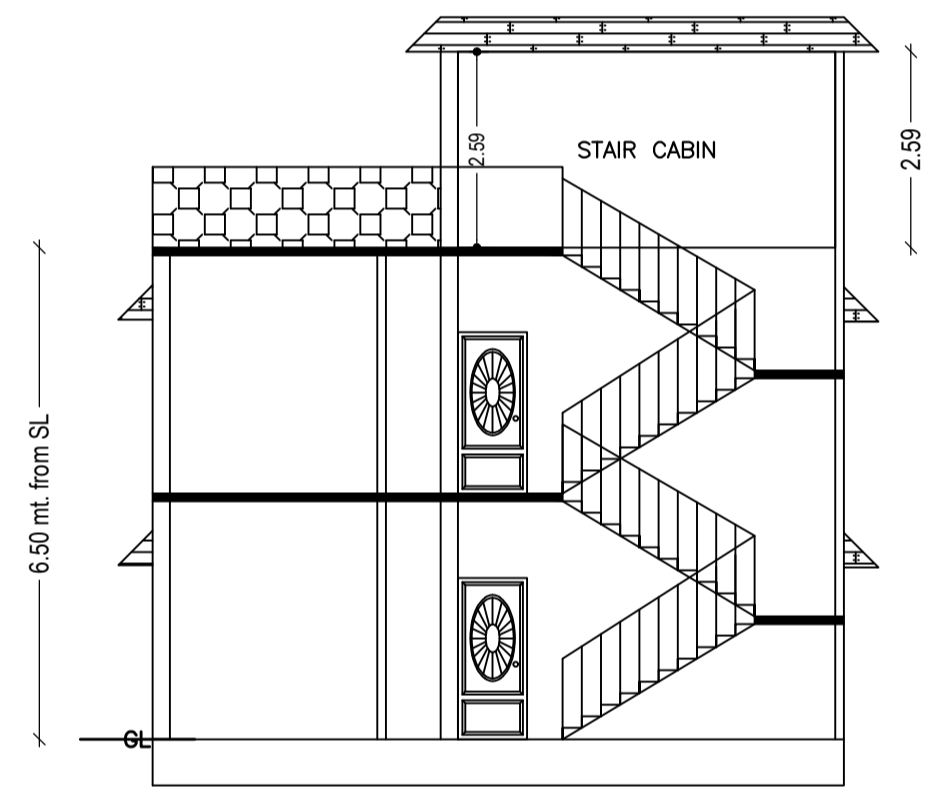

SECTION ON XX

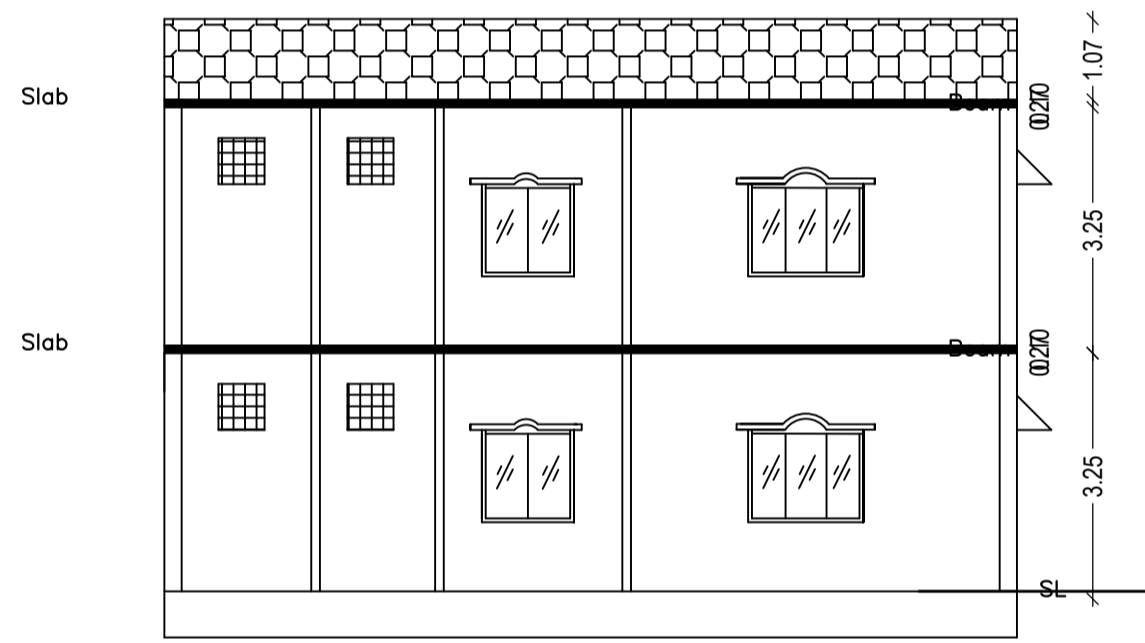

SECTION ON YY

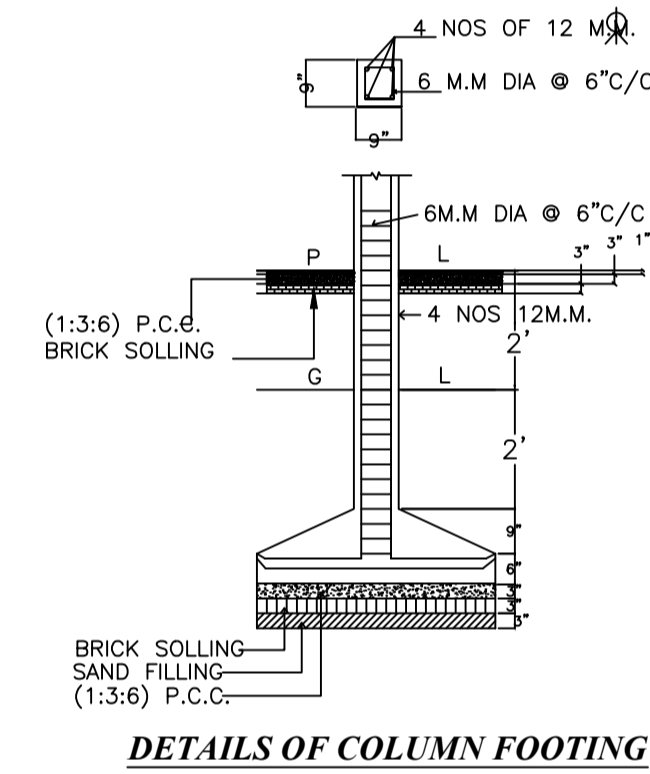

DETAILS OF COLUMN FOOTING

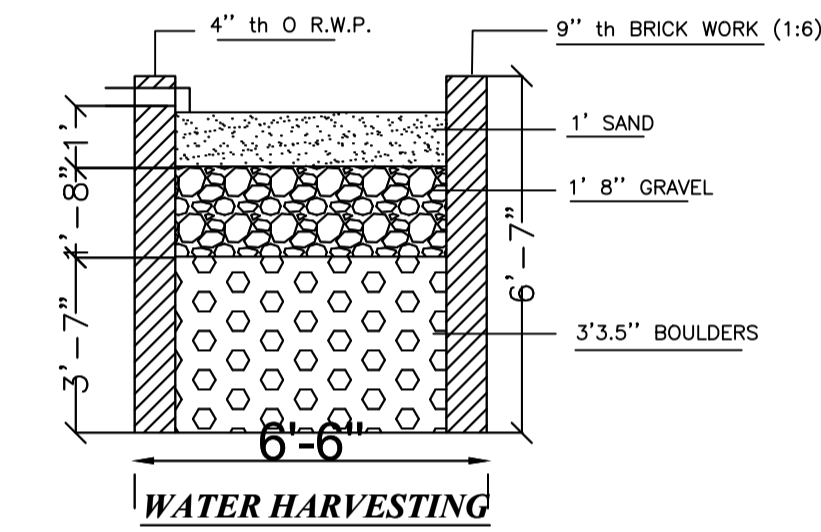

WATER HARVESTING

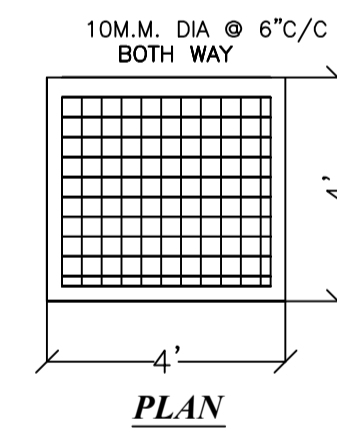

PLAN

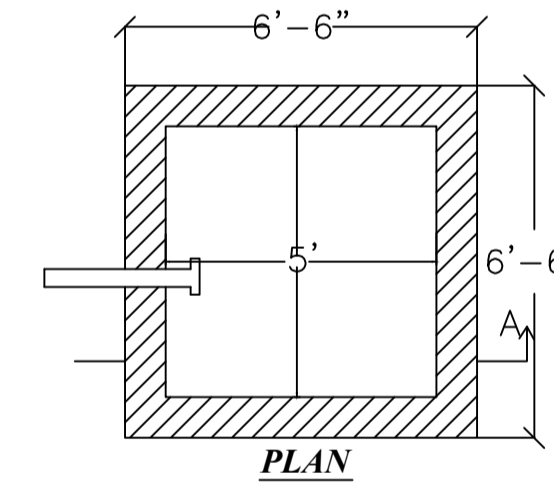

PLAN

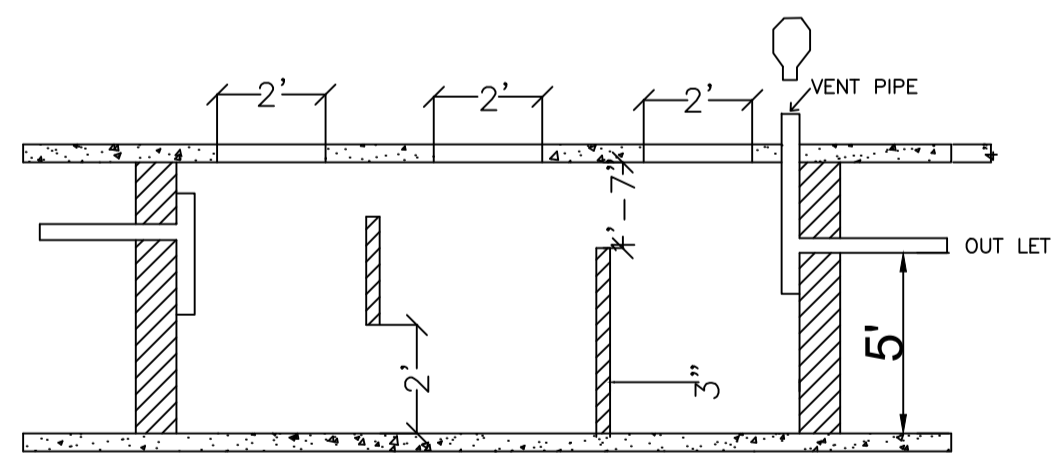

SECTION ON-XX

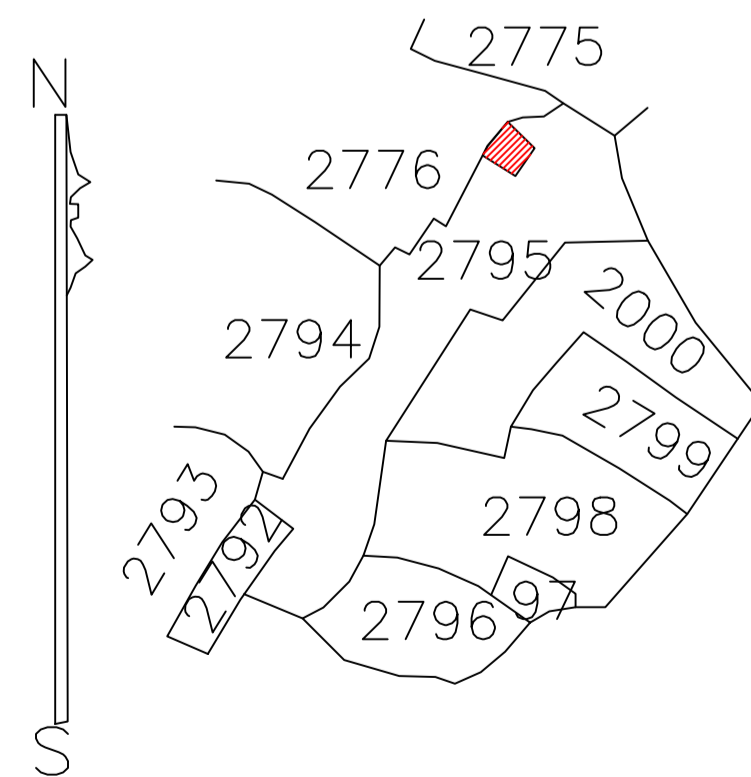

KEY PLAN  
1"=330'

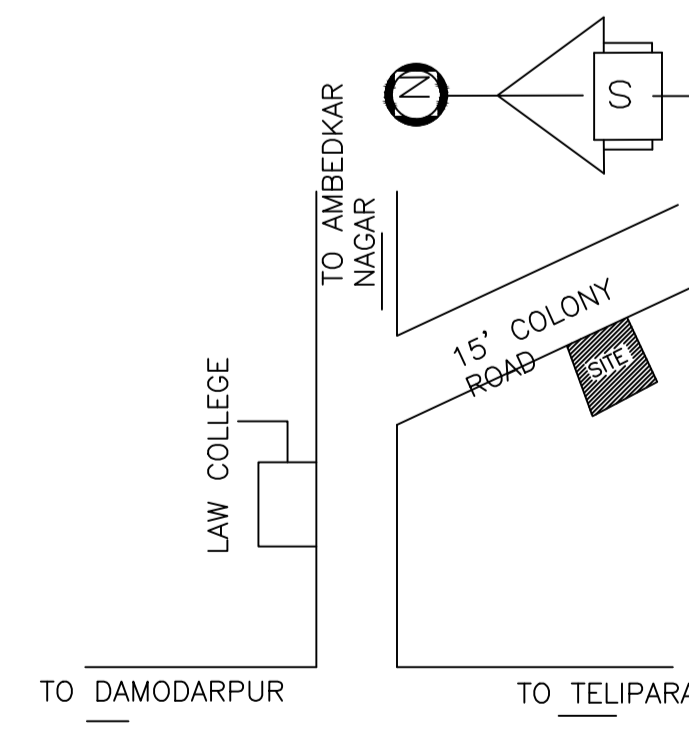

LOCATION PLAN

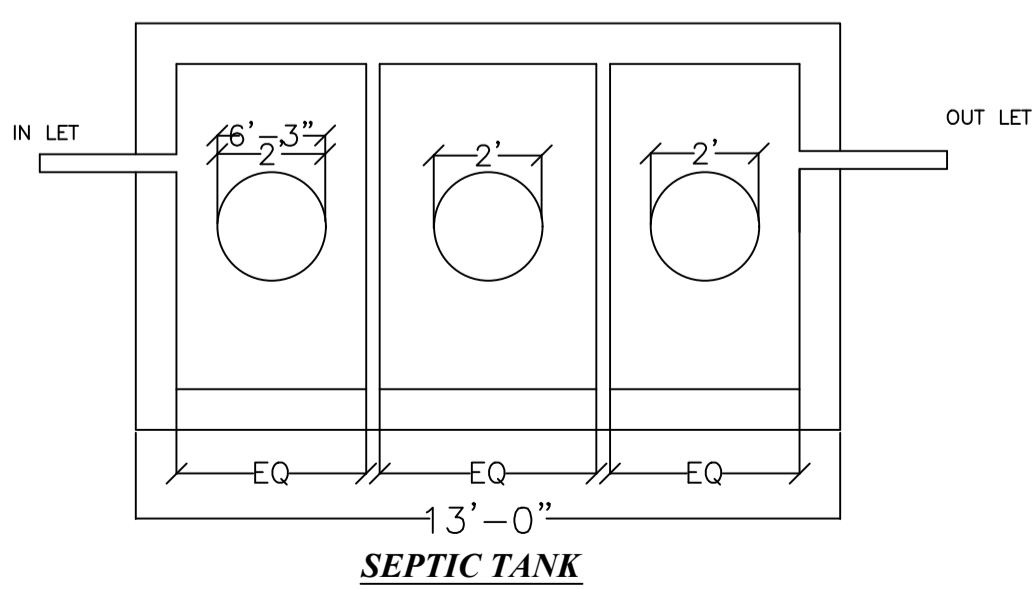

SEPTIC TANK

LTP NAME AND SIGNATURE	STRUCTURAL ENG'S NAME AND SIGNATURE	BUILDER NAME AND SIGNATURE	DIGITAL SIGNATURE
Santosh DMC/ENG/0019/2016			