

SITE PLAN

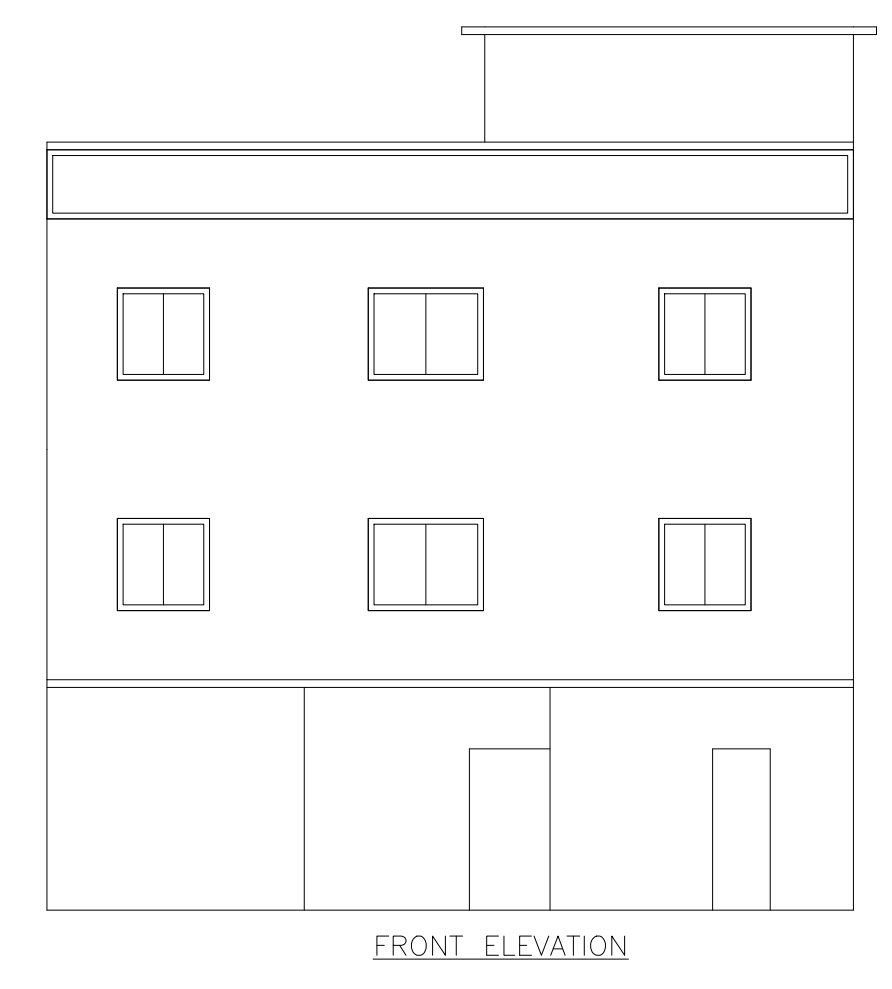

FRONT ELEVATION

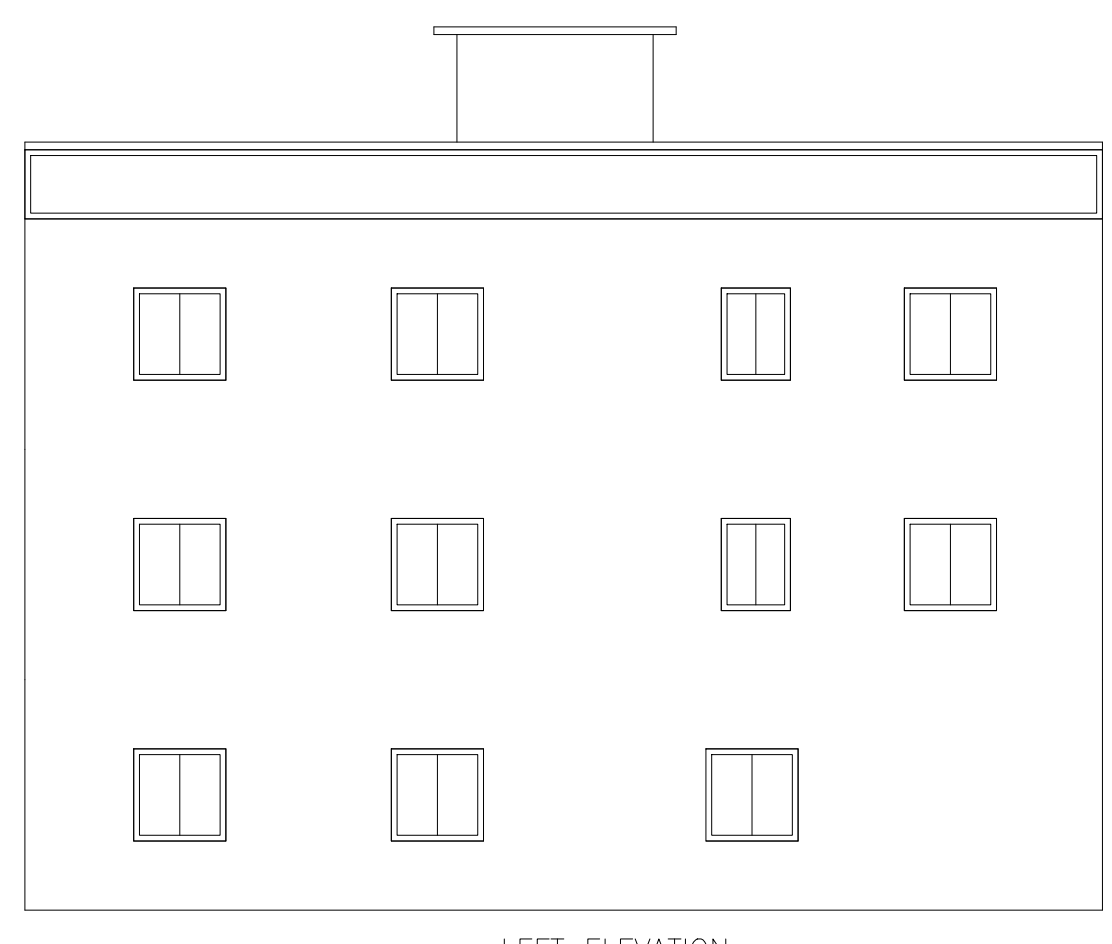

LEFT ELEVATION

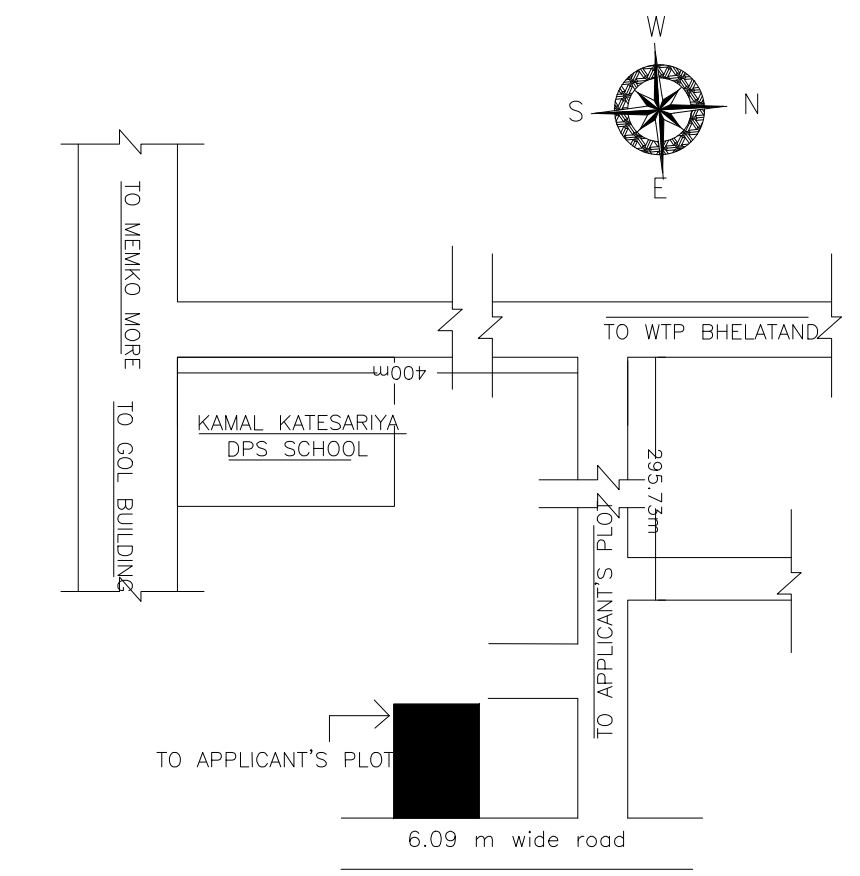

LOCATION PLAN
SCALE - NTS

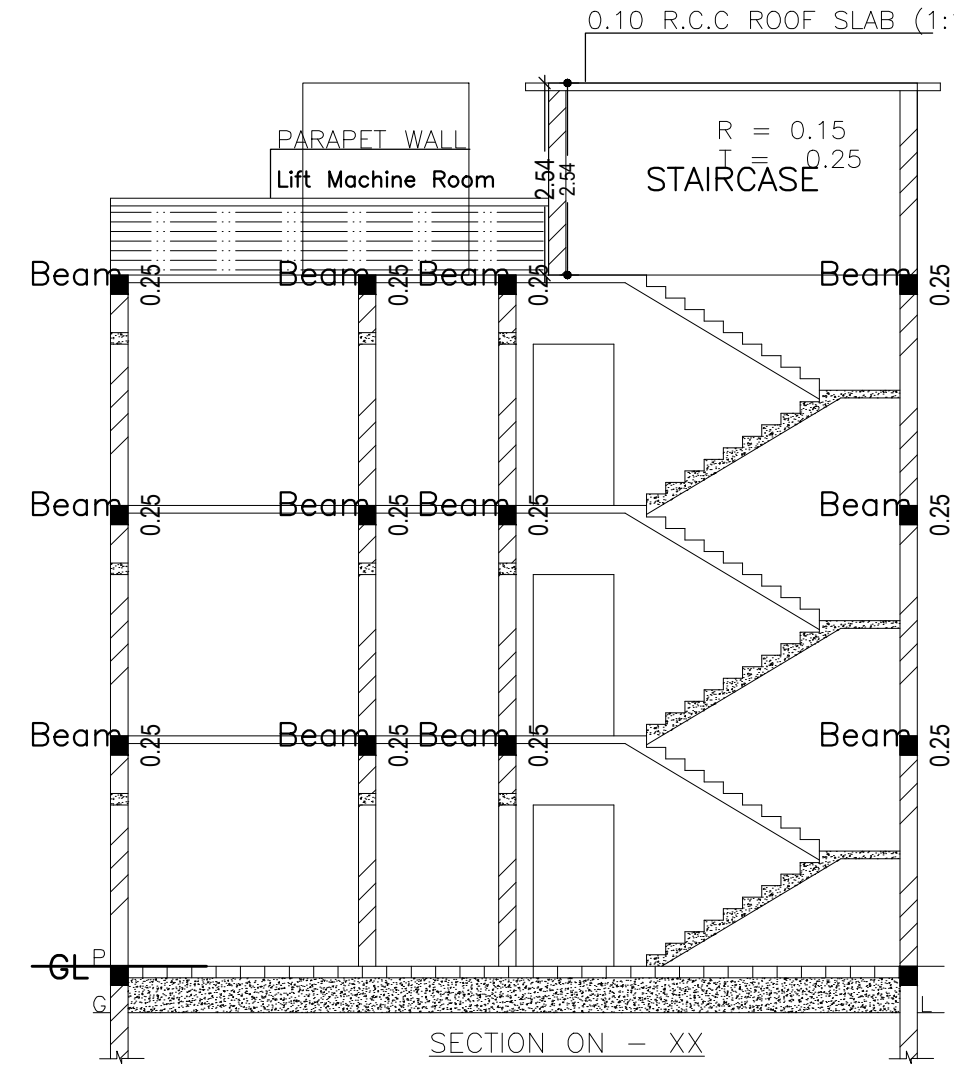

SECTION ON - XX

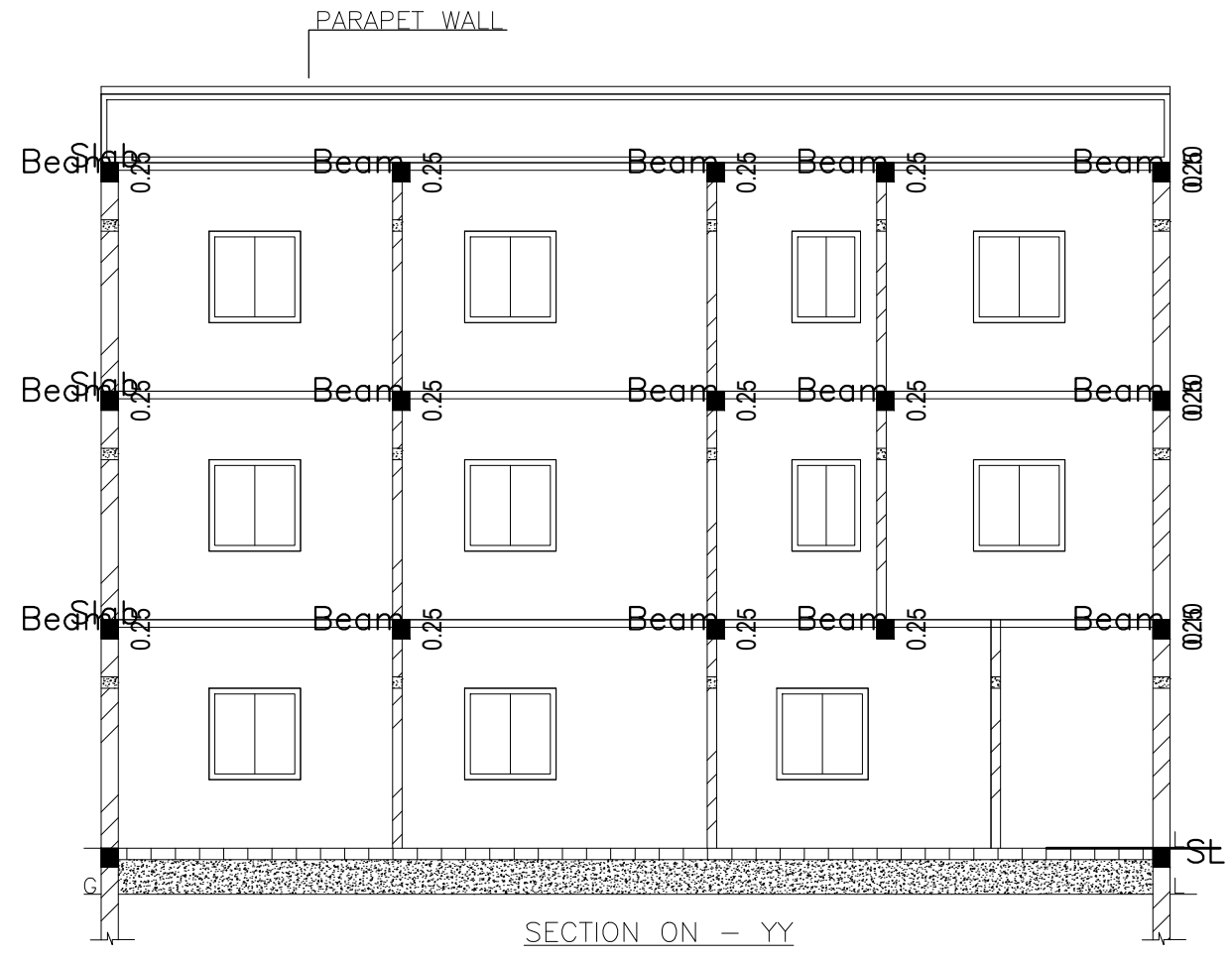

SECTION ON - YY

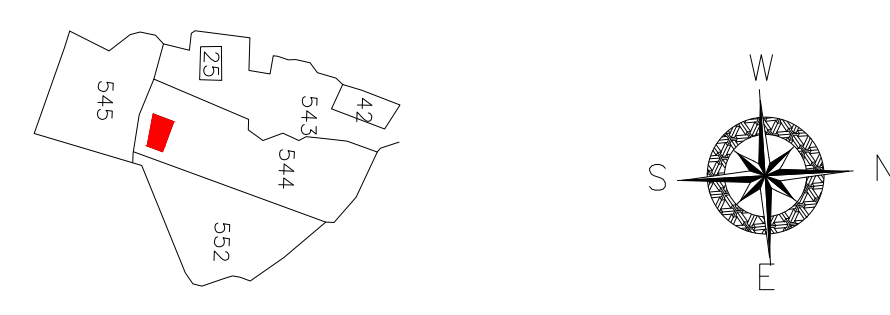

KEY PLAN

Proposal Basic Information	
Proposal File No.	DMC/BP/0315/W22/2021
Owner Name	SUMANT KUMAR SINGH
Khata No	NEW - 229 , OLD - 20
Plot No	NEW - 544 , OLD - 509
Village Name	Bhelatand
Use	Residential
SubUse	Bungalow/ Dwelling / Non Apartment

AREA STATEMENT	
DHANBAD MUNICIPAL CORPORATION	VERSION NO.: 1.0.61
PROJECT DETAIL:	VERSION DATE: 16/10/2020
Region: JHARKHAND URBAN LOCAL BODIES	Plot Use: Residential
District: DHANBAD	Plot SubUse: Bungalow/ Dwelling / Non Apartment
Authority: DHANBAD MUNICIPAL CORPORATION	PlotNearby/ReligiousStructure: NA
Inward_No: DMC/BP/0315/W22/2021	Plot/SubPlot No: NEW - 544 , OLD - 509
Application Type: General Proposal	North: Plot No. - SMT. SITA DEVI
Project Type: Building Permission	South: Plot No. - NEW PLOT NO. 544
Nature of Development: New	East: Road Width - 6.09 M WIDE ROAD
Location of Development Area: Old Area	West: Plot No. - PART OF NEW PLOT NO. 544

AREA DETAILS:	AREA	SQ.MT.
AREA OF PLOT (Minimum)	(A)	198.13
NET AREA OF PLOT(Gross Plot Area - Deduction from Gross Plot area)	(A-Deductions)	198.13
Deduction for Balance Plot Area(from Gross Plot Area)		
Common Plot		18.38
Total		18.38
BALANCE AREA OF PLOT(Net Plot Area - Recreational/Amenity space)	(A-Deductions)	179.75
PLOT AREA FOR COVERAGE(Net Plot Area)	(A-Deductions)	198.13
Plot Area for FAR (Net Plot Area + Road/Widening Area)	(A-Deductions)	198.13
COVERAGE CHECK		
Permissible Coverage area (70.00 %)		138.69
Proposed Coverage Area (50.22 %)		99.50
Total Prop. Coverage Area (50.22 %)		99.50
Balance coverage area (19.78 %)		39.19
FAR CHECK		
Perm. FAR Area (1.80)		356.63
Total Perm. FAR area		356.63
Residential FAR		347.21
Proposed FAR Area		347.21
Total Proposed FAR Area		347.21
Consumed FAR (Factor)		1.75
Balance FAR Area		9.42
BUILT UP AREA CHECK		
Total Proposed BuiltUp Area		354.60
ARCHITECT (Regd)		AMARENDRA KUMAR
ENGINEER (Regd)		
SUPERVISOR (Regd)		
OWNER (Regd)		SUMANT KUMAR SINGH
DEVELOPMENT AUTHORITY		LOCAL BODY

COLOR INDEX	
PLOT BOUNDARY	Black
ABUTTING ROAD	Green
PROPOSED CONSTRUCTION	Red
COMMON PLOT	Yellow
ROAD WIDENING AREA	Blue
EXISTING (To be retained)	Light Blue
EXISTING (To be demolished)	White

Building USE/SUBUSE Details

Building Name	Building Use	Building SubUse	Building Structure
AA (BB)	Residential	Bungalow/ Dwelling / Non Apartment	Non-Highrise

SCHEDULE OF DOOR:

BUILDING NAME	NAME	LENGTH	HEIGHT	NOS
AA (BB)	D	0.76	2.10	09
AA (BB)	D	0.91	2.10	05
AA (BB)	D	1.07	2.10	16
AA (BB)	D	1.09	2.10	03

SCHEDULE OF WINDOW/VENTILATION:

BUILDING NAME	NAME	LENGTH	HEIGHT	NOS
AA (BB)	W	0.61	1.20	09
AA (BB)	W	0.91	1.20	06
AA (BB)	W	1.22	1.20	25
AA (BB)	W	1.52	1.20	02

Building :AA (BB)

Floor Name	Total Built Up Area (Sq.mt.)	Deductions (Area in Sq.mt.)		Proposed FAR Area (Sq.mt.)	Total FAR Area (Sq.mt.)	Total Consumed Additional FAR Area (Sq.mt.)	Tnmt (No.)
		Lift	Resi.				
Ground Floor	99.50	0.00	0.00	99.50	99.50	0.00	01
First Floor	127.55	3.69	0.00	123.86	123.86	0.00	00
Second Floor	127.55	3.69	0.00	123.86	123.86	0.00	00
Terrace Floor	0.00	0.00	0.00	0.00	0.00	0.00	00
Total :	354.60	7.38	0.00	347.22	347.22	0.00	01
Total Number of Same Buildings :	1						
Total :	354.60	7.38	0.00	347.22	347.22	0.00	01

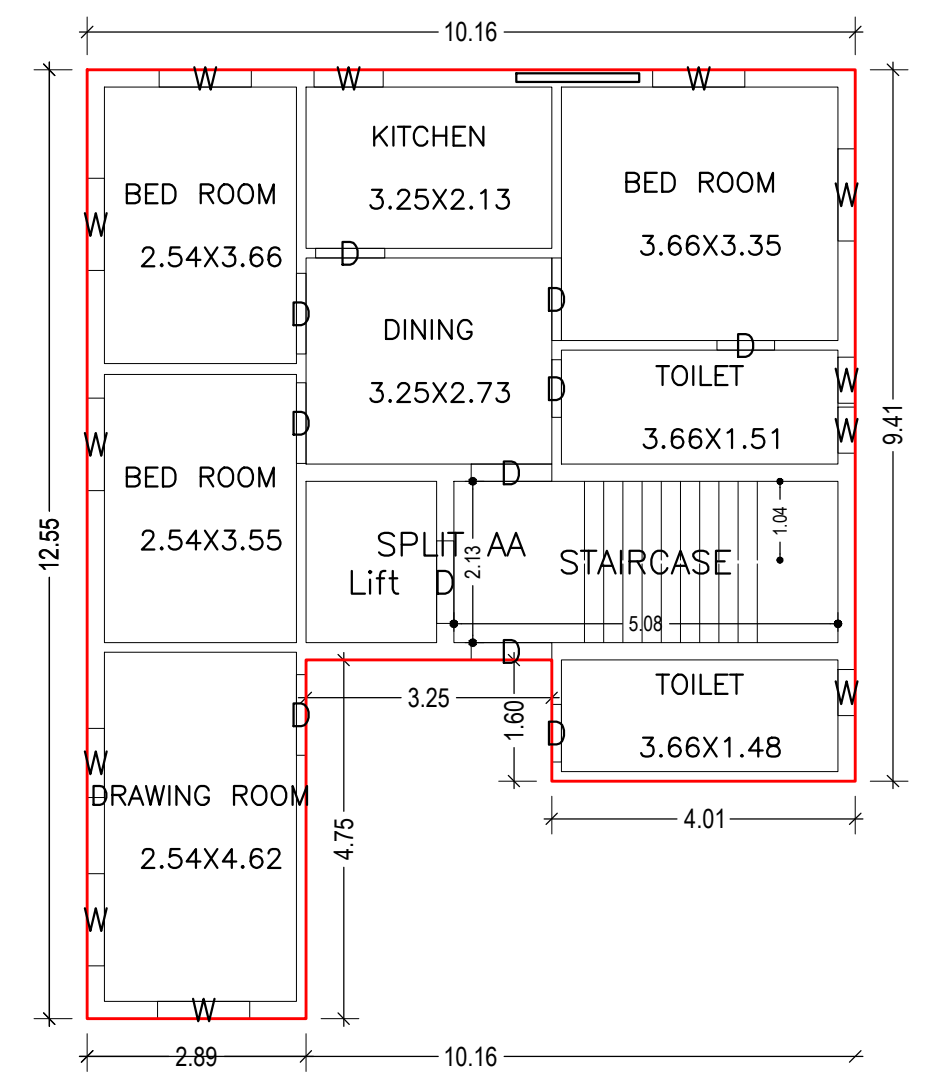

GROUND FLOOR PLAN
(Proposed)
(SCALE 1:100)

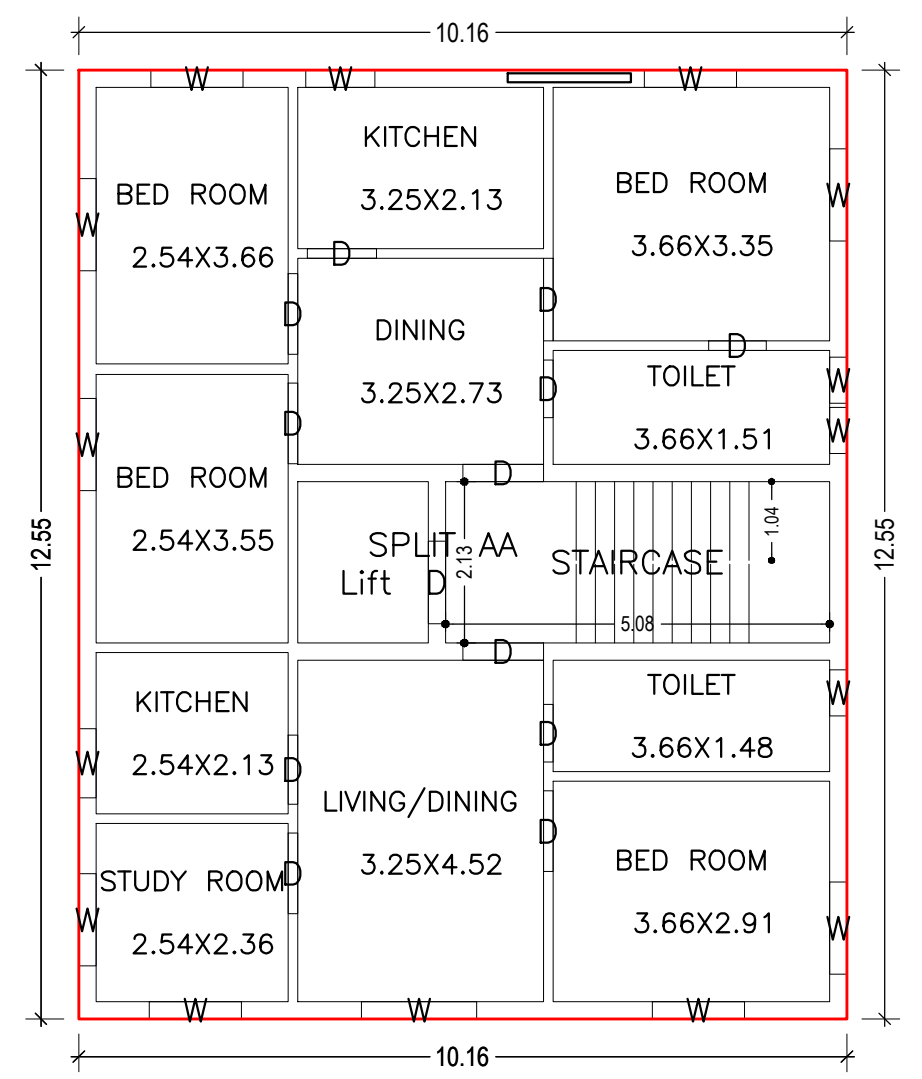

FIRST FLOOR PLAN
(Proposed)
(SCALE 1:100)

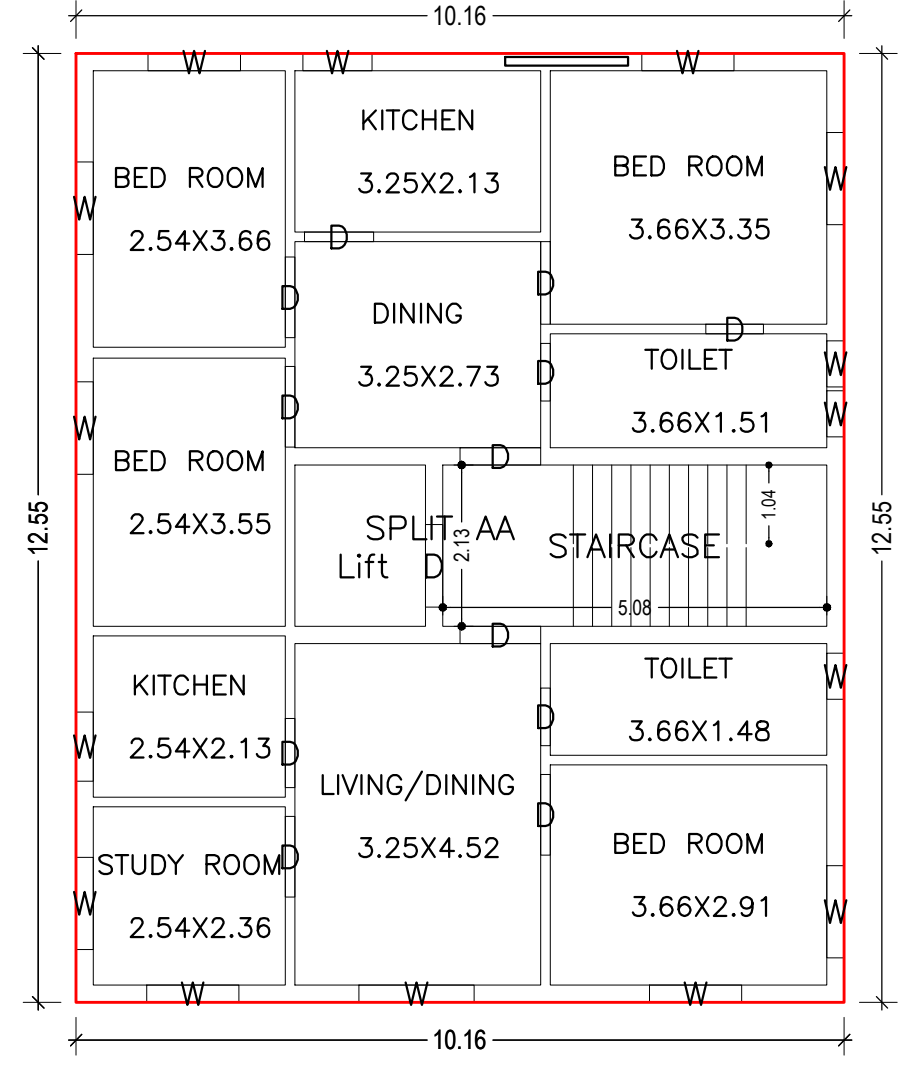

SECOND FLOOR PLAN
(Proposed)
(SCALE 1:100)

Buildingwise Floor FAR Details

Floor Name	Building Name AA (BB)		Total	
	Proposed Built Up Area (Sq.mt.)	Proposed FAR Area (Sq.mt.)	Total Proposed Built Up Area (Sq.mt.)	Total FAR Area (Sq.mt.)
Ground Floor	99.50	99.50	99.50	99.50
First Floor	127.55	123.86	127.55	123.86
Second Floor	127.55	123.86	127.55	123.86
Terrace Floor	0.00	0.00	0.00	0.00
Total :	354.60	347.22	354.60	347.22

FAR & Tenement Details (Table 4c-1)

Building	No. of Same Bldg	Total Built Up Area (Sq.mt.)	Deductions (Area in Sq.mt.)		Proposed FAR Area (Sq.mt.)	Total FAR Area (Sq.mt.)	Total Consumed Additional FAR Area (Sq.mt.)	Tnmt (No.)
			Lift	Resi.				
AA (BB)	1	354.60	7.38	0.00	347.22	347.22	347.22	01
Grand Total :	1	354.60	7.38	0.00	347.22	347.22	347.22	01

UnitBUA Table for Building :AA (BB)

FLOOR	Name	UnitBUA Type	UnitBUA Area	Carpet Area	No. of Rooms	No. of Tenement
FIRST FLOOR PLAN	SPLIT AA	FLAT	0.00	0.00	11	0
SECOND FLOOR PLAN	SPLIT AA	FLAT	0.00	0.00	11	0
GROUND FLOOR PLAN	SPLIT AA	FLAT	343.52	342.95	8	1
Total:	-	-	343.52	342.95	30	1

LTP NAME AND SIGNATURE	STRUCTURAL ENG'S NAME AND SIGNATURE	BUILDER NAME AND SIGNATURE	DIGITAL SIGNATURE
AMARENDRA KUMAR DMC/ENG/0009/2016			

Proposal Basic Information

Proposal File No.	DMC/BP/0315/W22/2021
Owner Name	SUMANT KUMAR SINGH
Khata No	NEW - 229 , OLD - 20
Plot No	NEW - 544 , OLD - 509
Village Name	Bhelaland
Use	Residential
SubUse	Bungalow/ Dwelling / Non Apartment

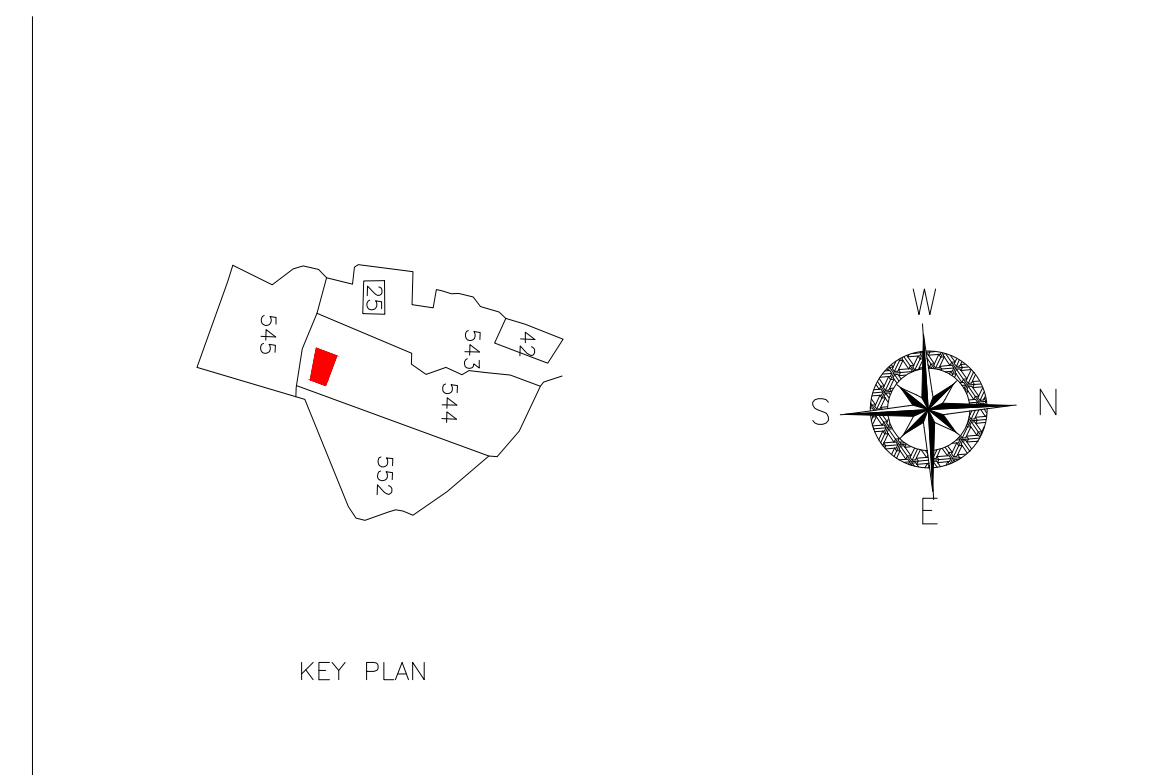
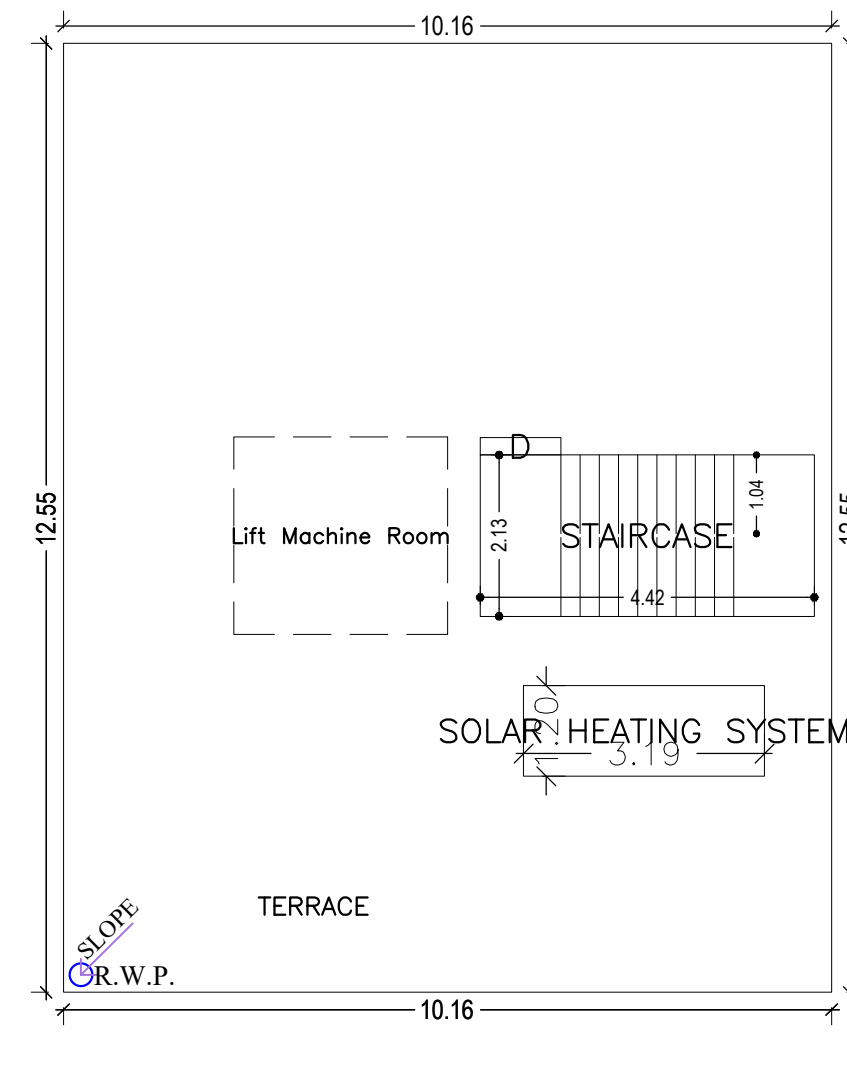
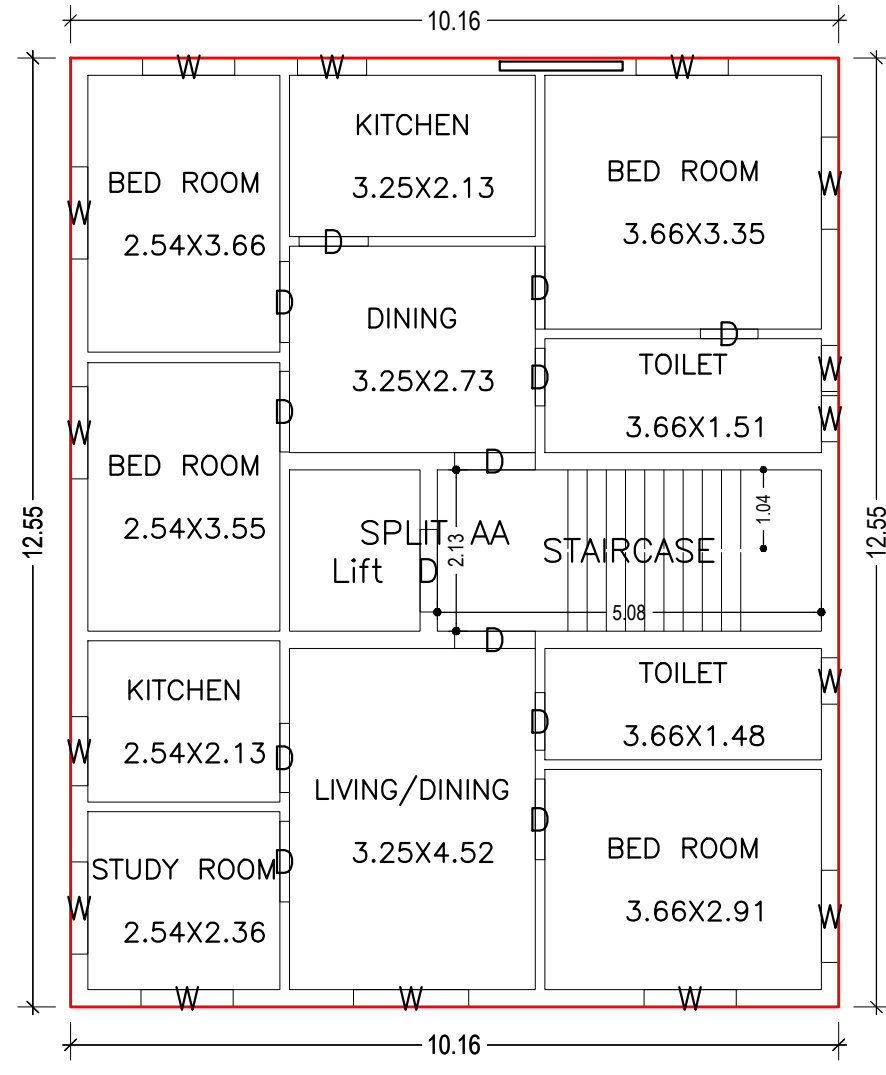
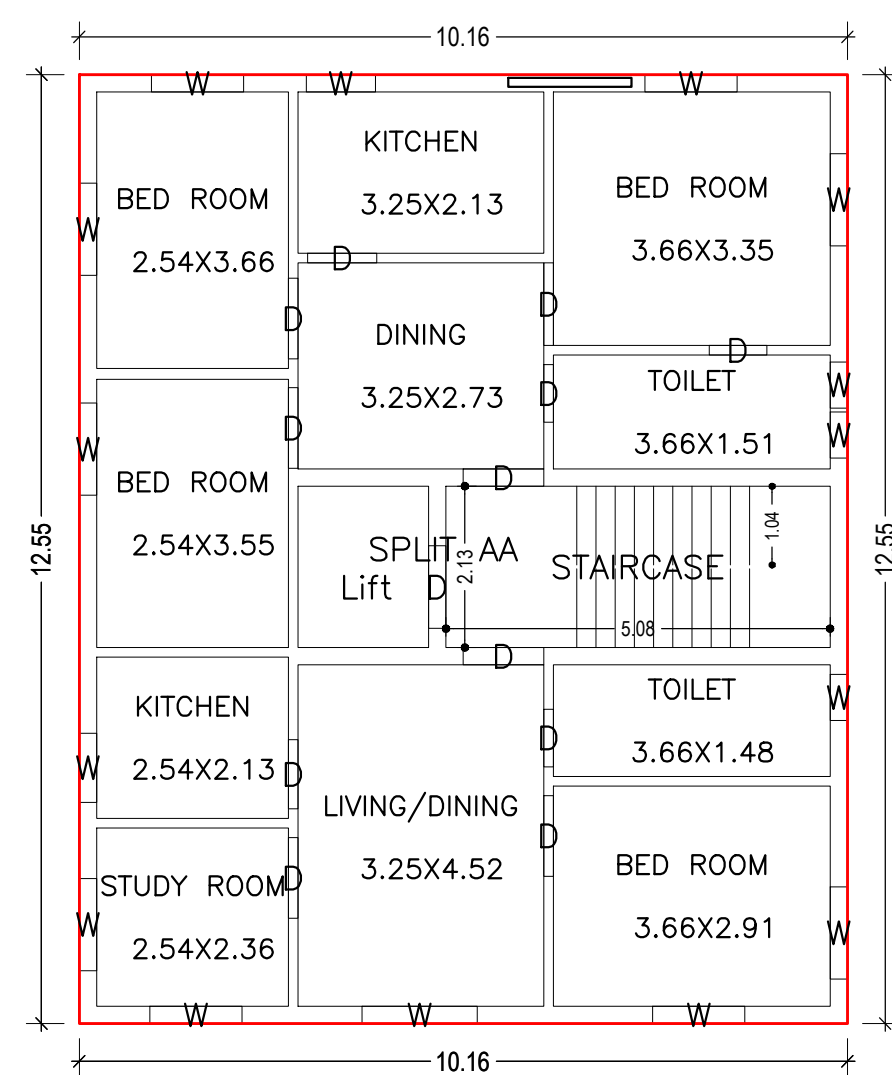
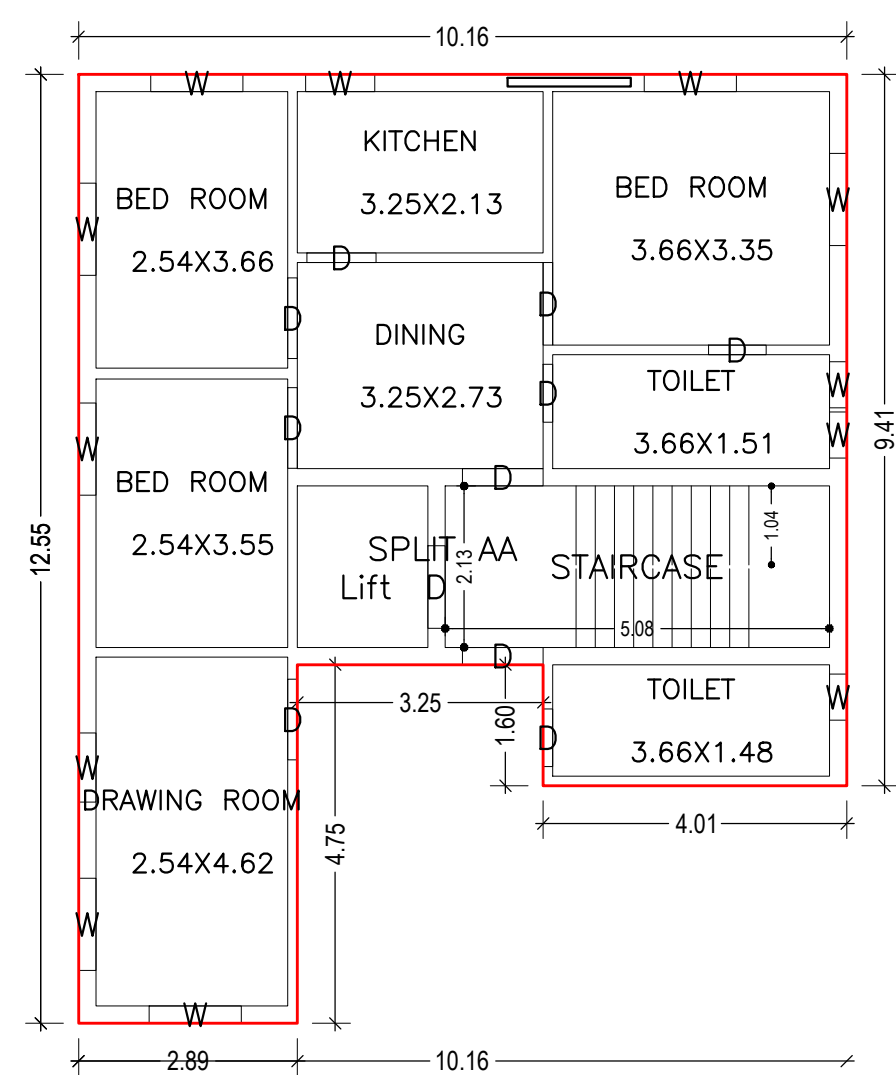
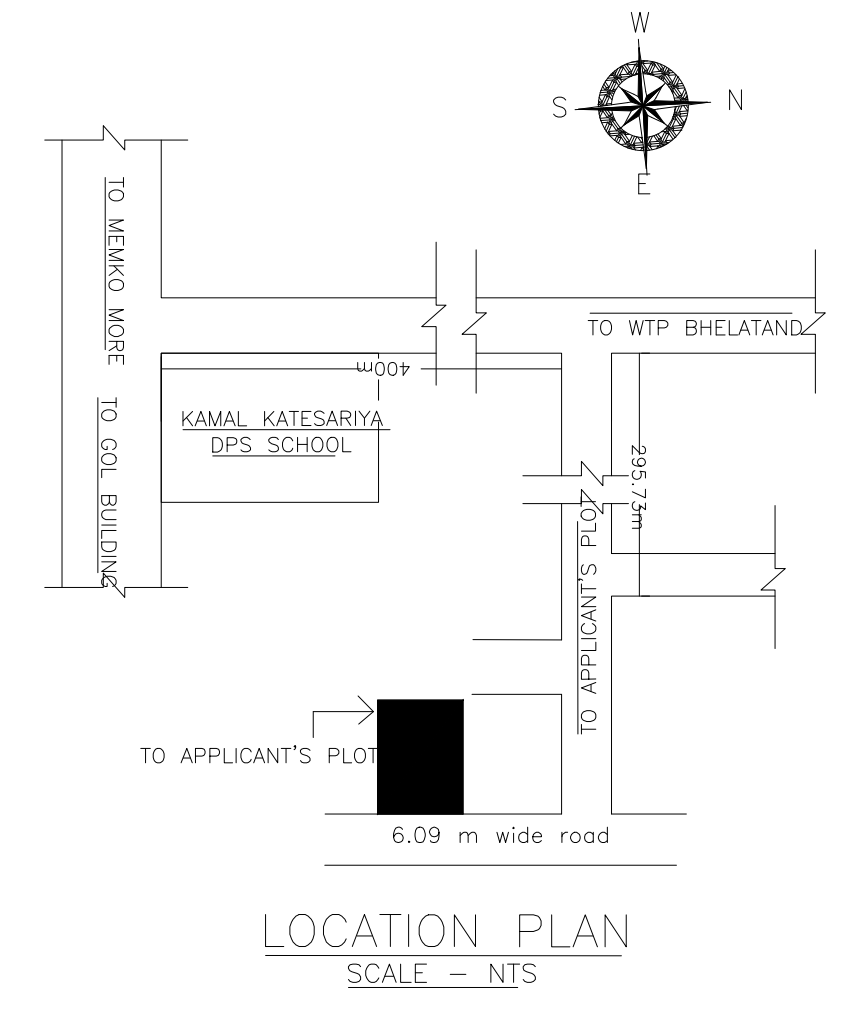
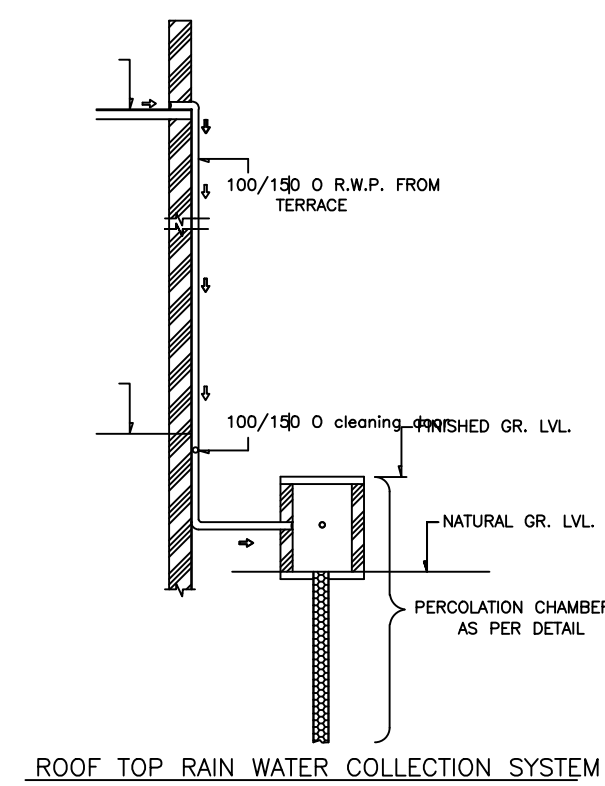
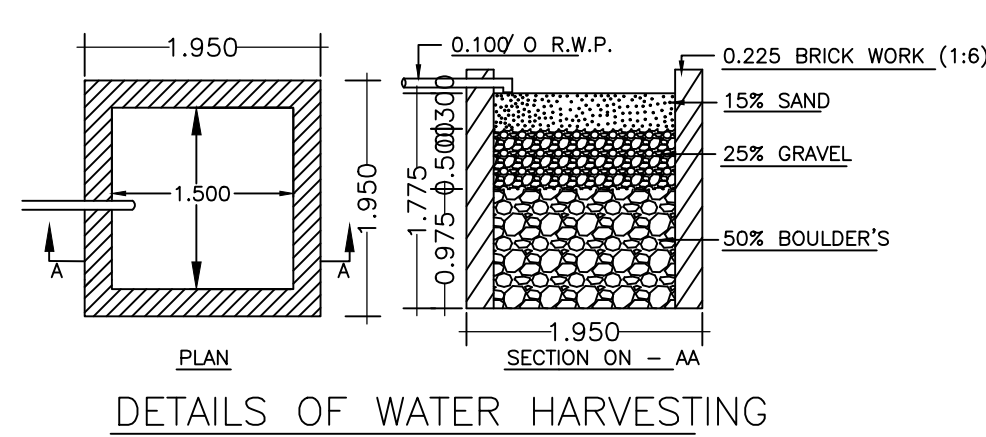
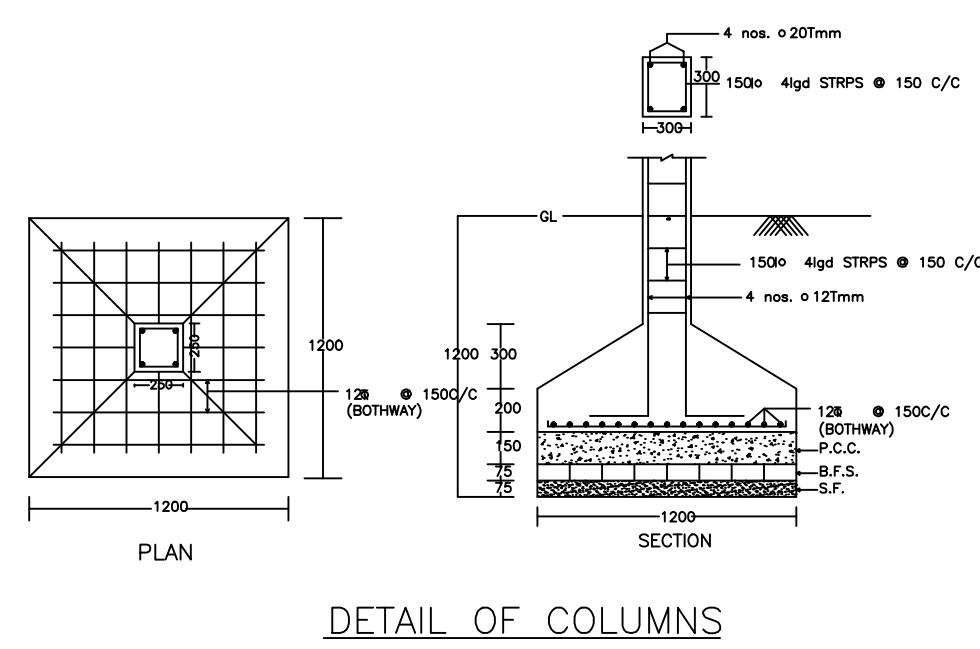
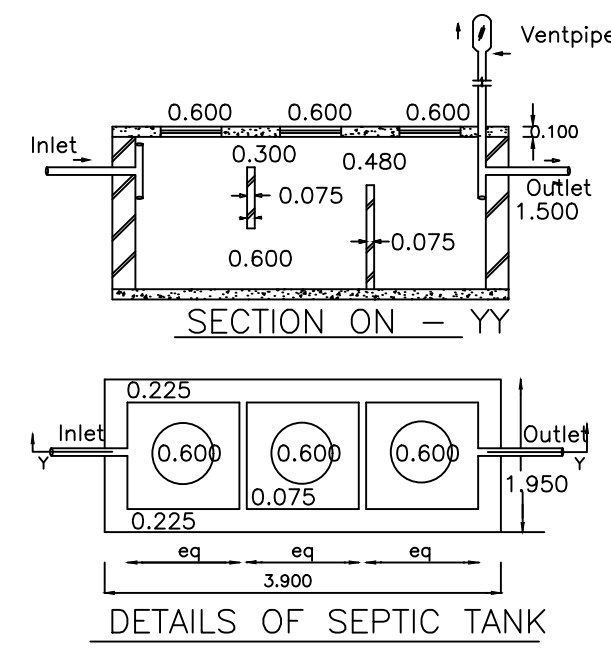
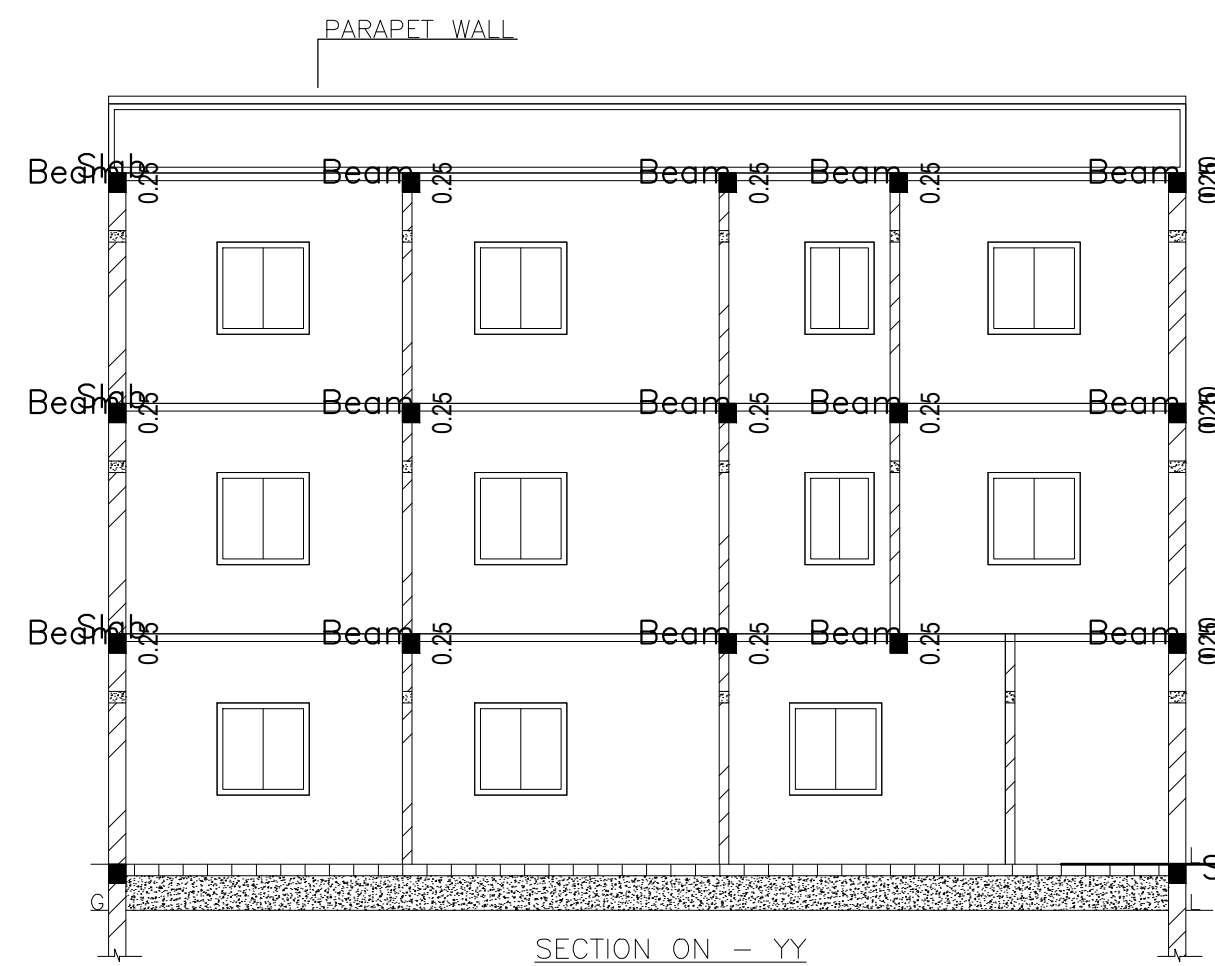
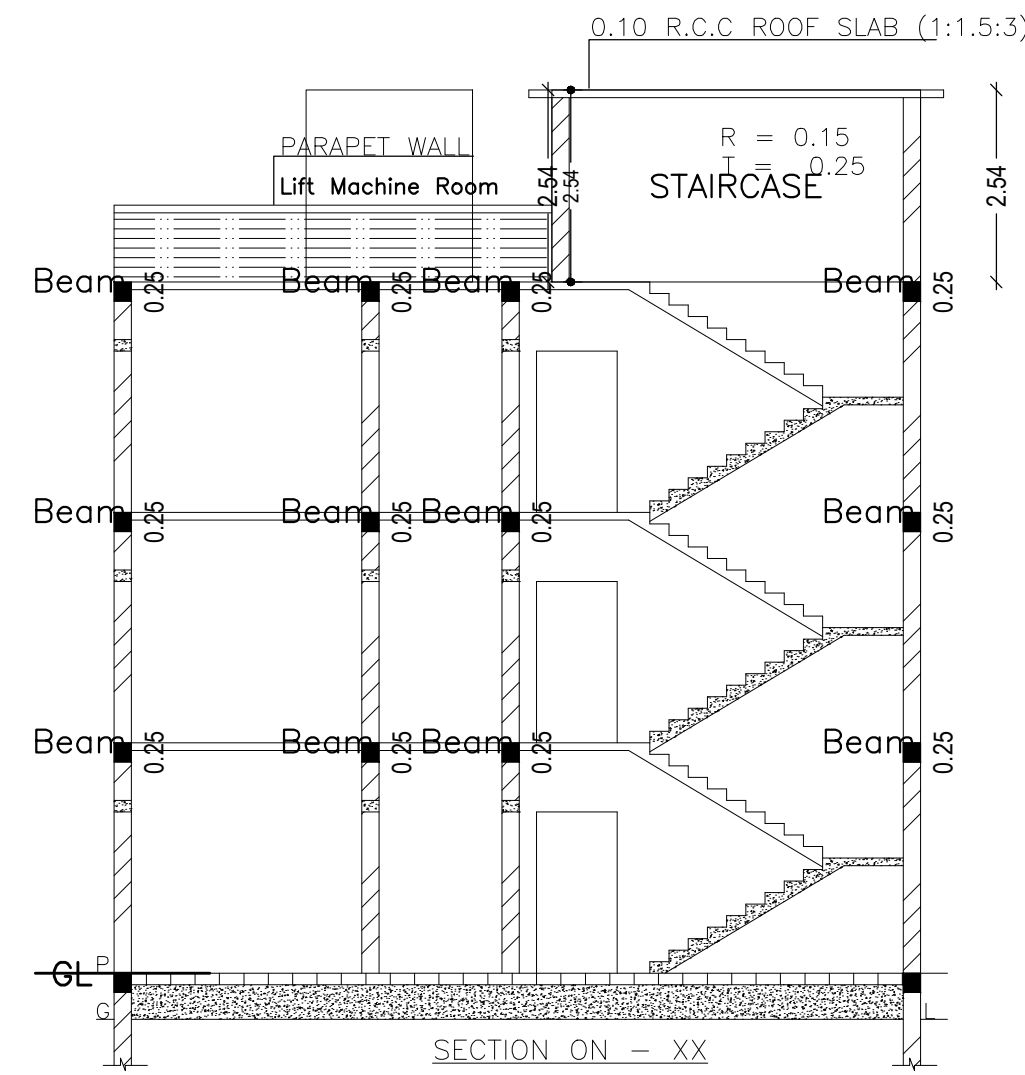
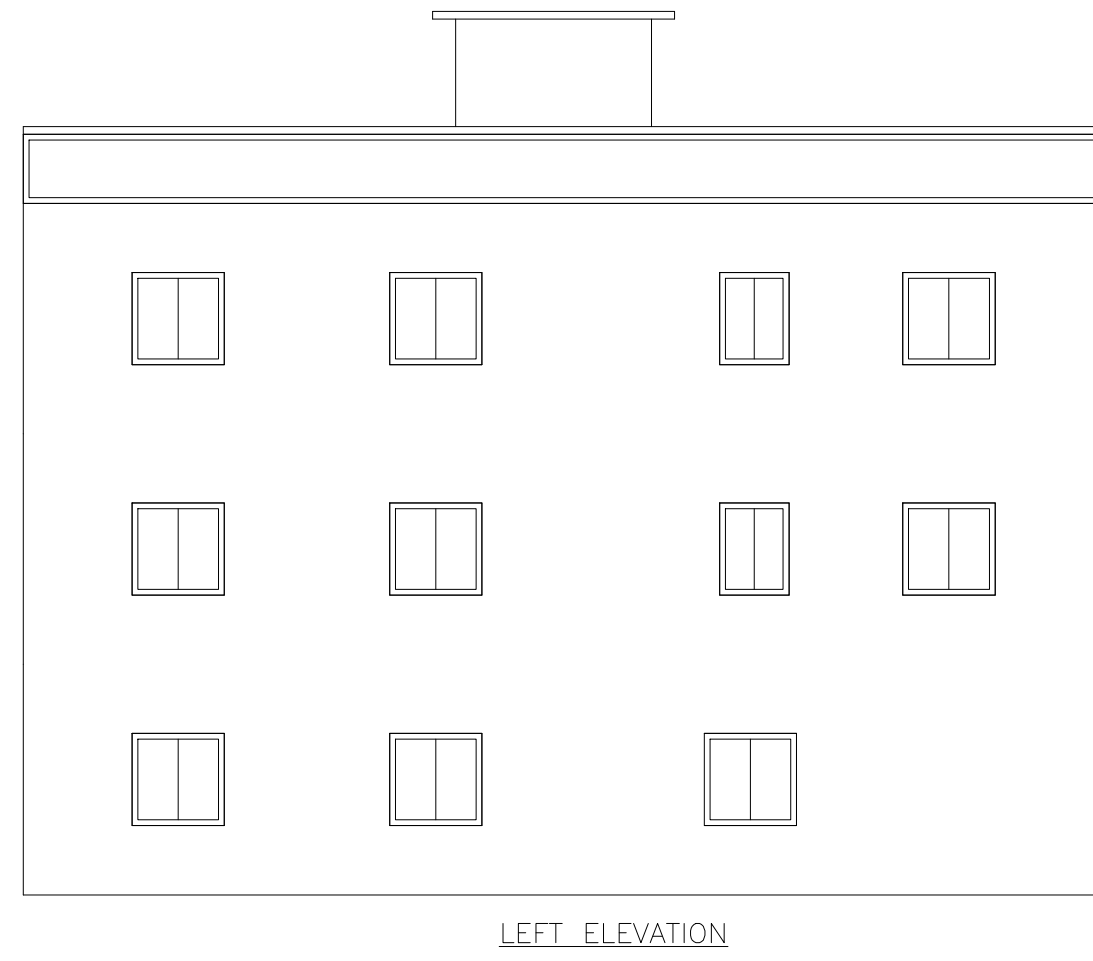
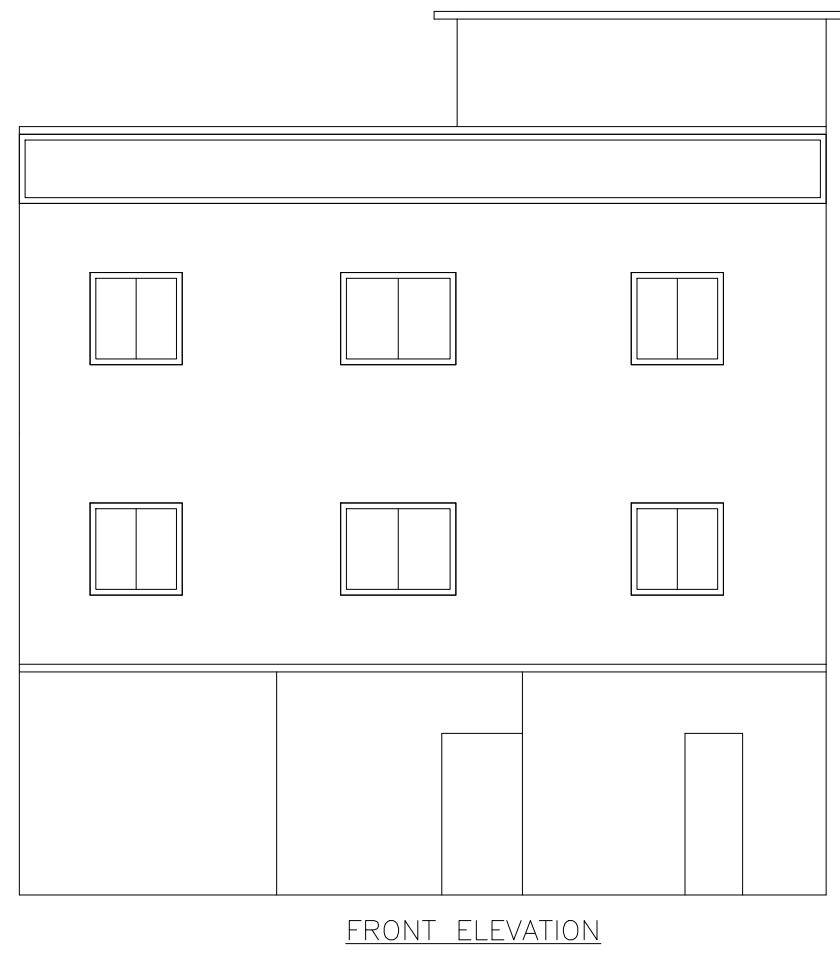

LTP NAME AND SIGNATURE	STRUCTURAL ENG'S NAME AND SIGNATURE	BUILDER NAME AND SIGNATURE	DIGITAL SIGNATURE
AMARENDRA KUMAR DMC/ENG/0009/2016			