

Project Title :SONAM KUMAR

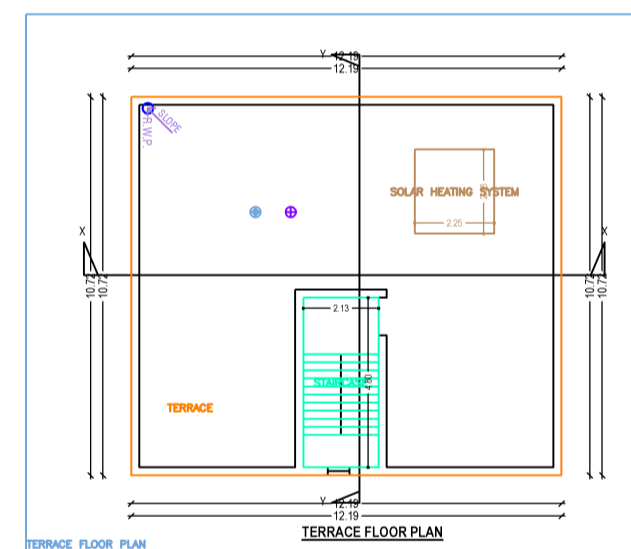
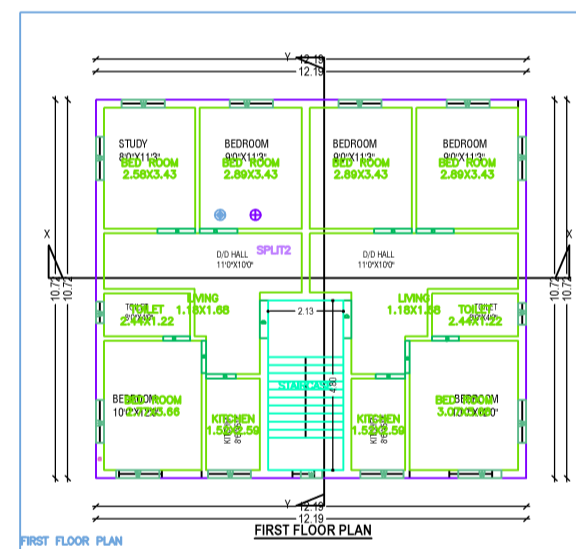
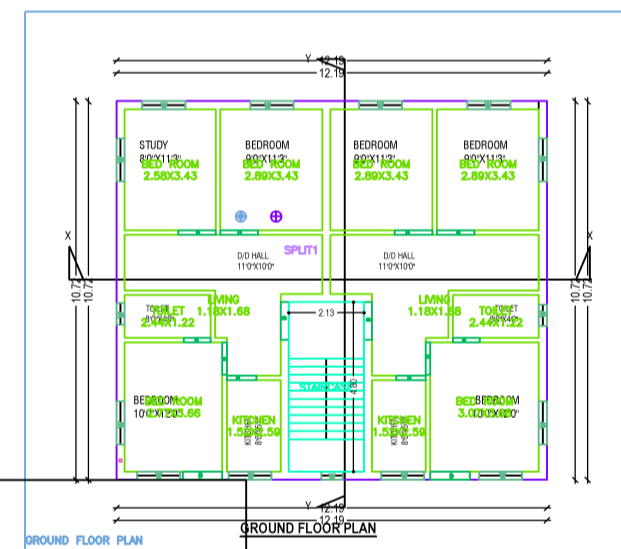
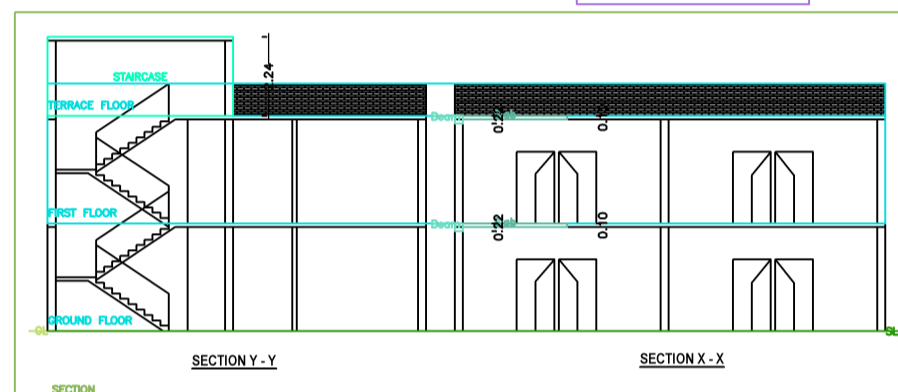
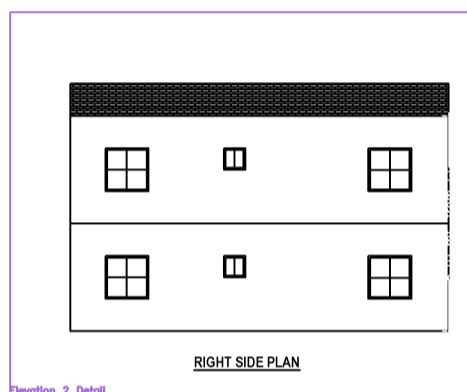
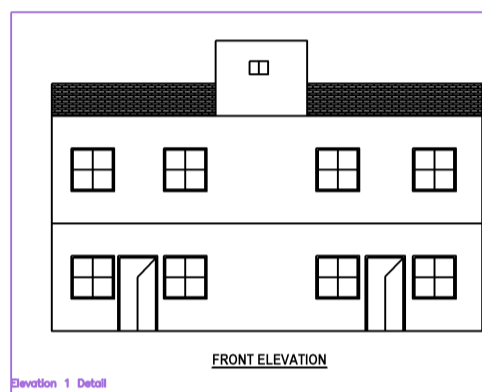
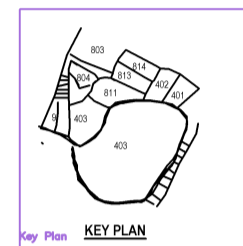
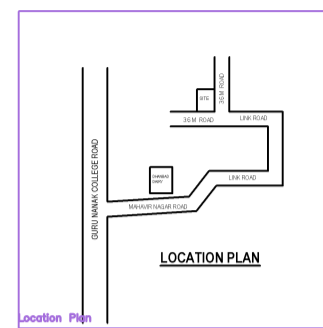
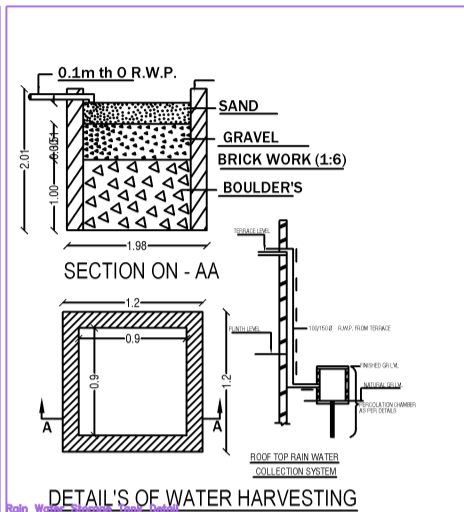
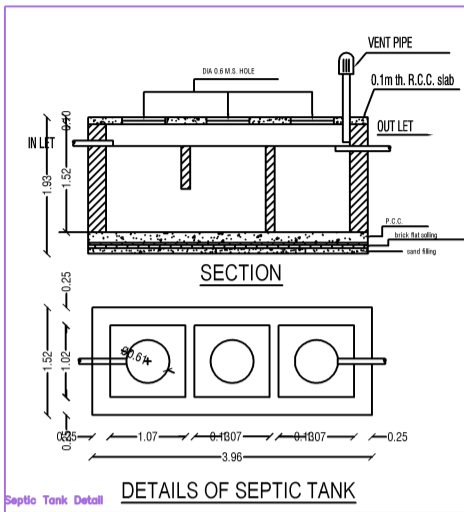
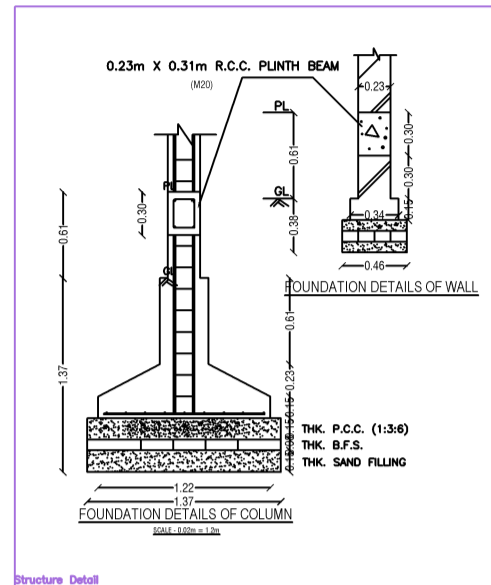

BRIEF SPECIFICATION

FOUNDATION - R.C.C. (1:1.5:3) Column footing foundation.
PLINTH - 12"th R.C.C. (1:1.5:3) all round on plinth level.
FLOORING - 1.5"th Marble, flooring over 3"th P.C.C. (1:3:6).
SUPER STRUCTURE - First class brick work in cement mortar (1:6).
SLAB,BEAM, stairs & LINTEL - All R.C.C. work (1:1.5:3).
WOOD WORK - All door & window frames of sal wood
PLASTERING - 12mm cement plaster (1:6) both side.

SCHEDULE

D1 - 1.07 X 2.13	W - 0.9 x 1.22
D2 - 0.9 X 2.13	W1 - 1.22 x 1.22
D3 - 0.76 x 2.13	W2 - 1.5 x 1.22
CG - 1.22 x 2.13	V - 0.61 x 0.61

TITLE OF DRAWING

SONAM KUMARI W/O NANDAN KUMAR OF MAHABIR NAGAR, BHUDA , DHANBAD ON MOUZA - BHUDA NO. 48, KHATA NO. 1, 25, PLOT NO. 804, 805 IN THE DISTRICT OF DHANBAD JHARKHAND

SIG. OF OWNER

SIG. OF ENGINEER

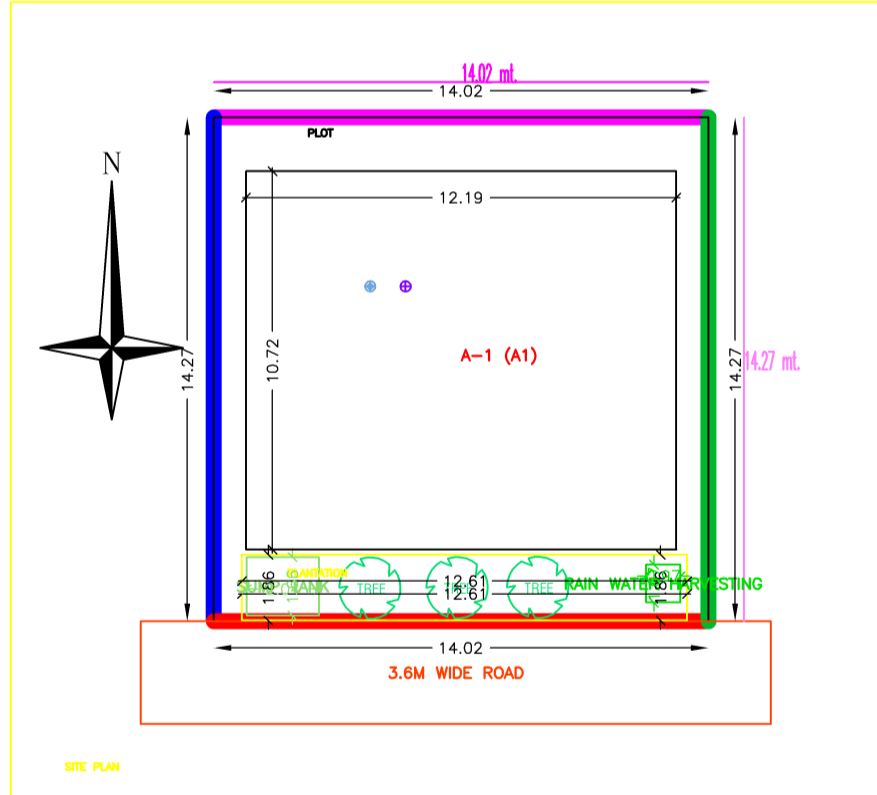

Building 'A' (A1)

Floor Name	Total Built Up Area (Sq.mt)	Proposed FAR Area (Sq.mt)	Total FAR Area (Sq.mt)	Tent (No.)
Ground Floor	130.68	130.68	130.68	01
First Floor	130.68	130.68	130.68	01
Terrace Floor	0.00	0.00	0.00	00
Total	261.36	261.36	261.36	02
Total Number of Same Buildings	1			
Total	261.36	261.36	261.36	02

SCHEDULE OF JOINERY:

BUILDING NAME	NAME	LENGTH	HEIGHT	NO.
A (A1)	D	0.76	2.10	04
A (A1)	D	0.84	2.10	04
A (A1)	D	0.81	2.10	04
A (A1)	D	1.07	2.10	12
A (A1)	D	1.12	2.10	02
Total				28

SCHEDULE OF JOINERY:

BUILDING NAME	NAME	LENGTH	HEIGHT	NO.
A (A1)	W	0.61	1.20	08
A (A1)	W	1.22	1.20	24
Total				32

UnitBUA Table for Building 'A' (A1)

FLOOR	Name	UnitBUA Type	UnitBUA Area	Carpet Area	No. of Rooms	No. of Tenement
GROUND FLOOR PLAN	SPLIT1	FLAT	130.68	130.68	12	1
FIRST FLOOR PLAN	SPLIT2	FLAT	130.68	130.68	12	1
Total			261.36	261.36	24	2

AREA STATEMENT: DHANBAD MUNICIPAL CORPORATION		VERSION NO. 1.0.31
TRICKERY DETAIL		VERSION DATE: 16/10/2020
Toward No.	Plot Use Residential	
Region - JHARKHAND URBAN LOCAL BODIES	Plot Subtype - Bungalow Dwelling / Non Apartment	
Location - DHANBAD	Local Use Zone - MR	
Application Type - General Proposal	Abutting Road Width -	
Project Type - Development Permission	Plot No. -	
Nature of Development - New	Reference Survey No/Survey No. -	
Location - Old Area	Thane No. -	
Sub Location - NA	Holding No. -	
Village/Moosa Name -	Khata No. -	
Ward No. -	North -	
Road/Street -	South -	
	East -	
	West -	

AREA DETAILS

AREA OF PLOT (Minimum)	(Sq. M)	SQ.MT
Total Plot Area (Gross Plot Area)	(A-Deductions)	200.14
Total Plot Area (Net Plot Area)	(A-Deductions)	179.63
Total Plot Area (Net Plot Area)	(A-Deductions)	200.14
Total Plot Area (Net Plot Area)	(A-Deductions)	200.14
Total Plot Area (Net Plot Area)	(A-Deductions)	200.14

COLOR INDEX

Color	Description
Green	Proposed Work (Coverage Area)
Red	Existing (To be retained)
Blue	Existing (To be demolished)

Color Index

Building	No. of Same Bldg	Total Built Up Area (Sq.mt)	Proposed FAR Area (Sq.mt)	Total FAR Area (Sq.mt)	Tent (No.)
A (A1)	1	261.36	261.36	261.36	02
Grand Total	1	261.36	261.36	261.36	02