

Proposal Basic Information

Proposal File No.	DMC/BP/0262/W30/2021
Owner Name	BHOLA ROUT
Khata No	OLD-156, NEW-155
Plot No	OLD-573, NEW-1124
Village Name	Patrakulhi
Use	Residential
SubUse	Bungalow/ Dwelling / Non Apartment

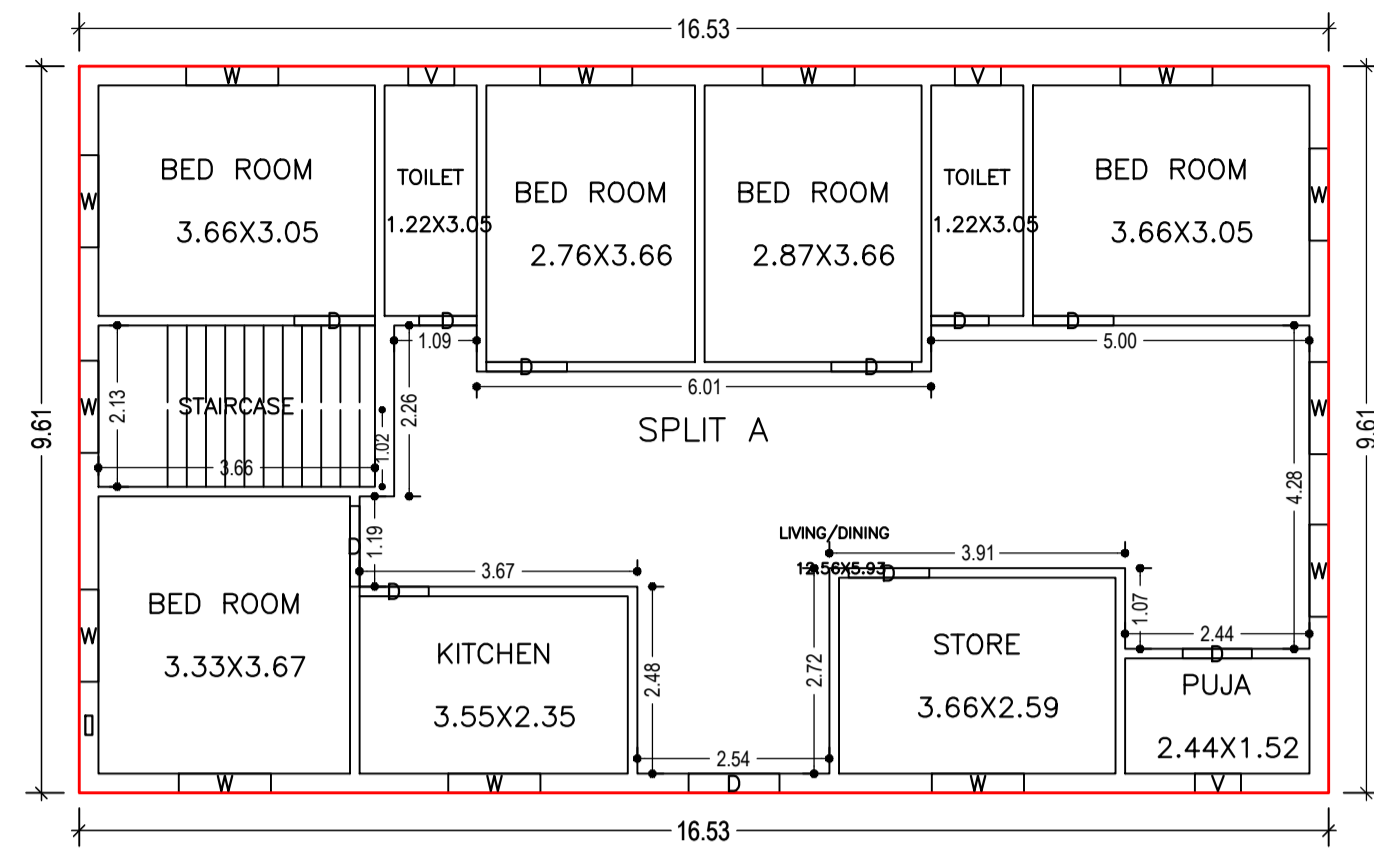

GROUND FLOOR PLAN
(Proposed)
(SCALE 1:100)

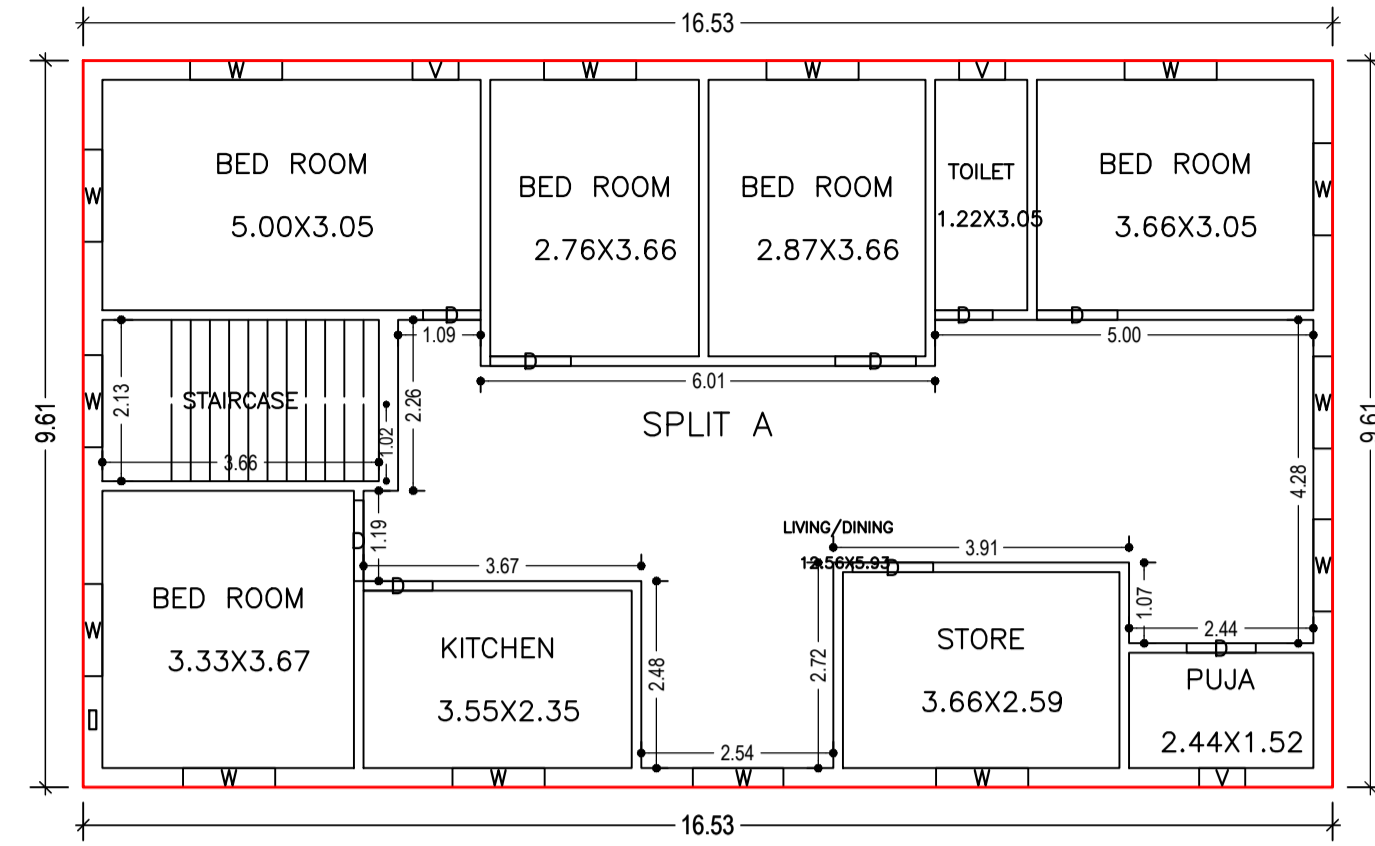

FIRST FLOOR PLAN
(Proposed)
(SCALE 1:100)

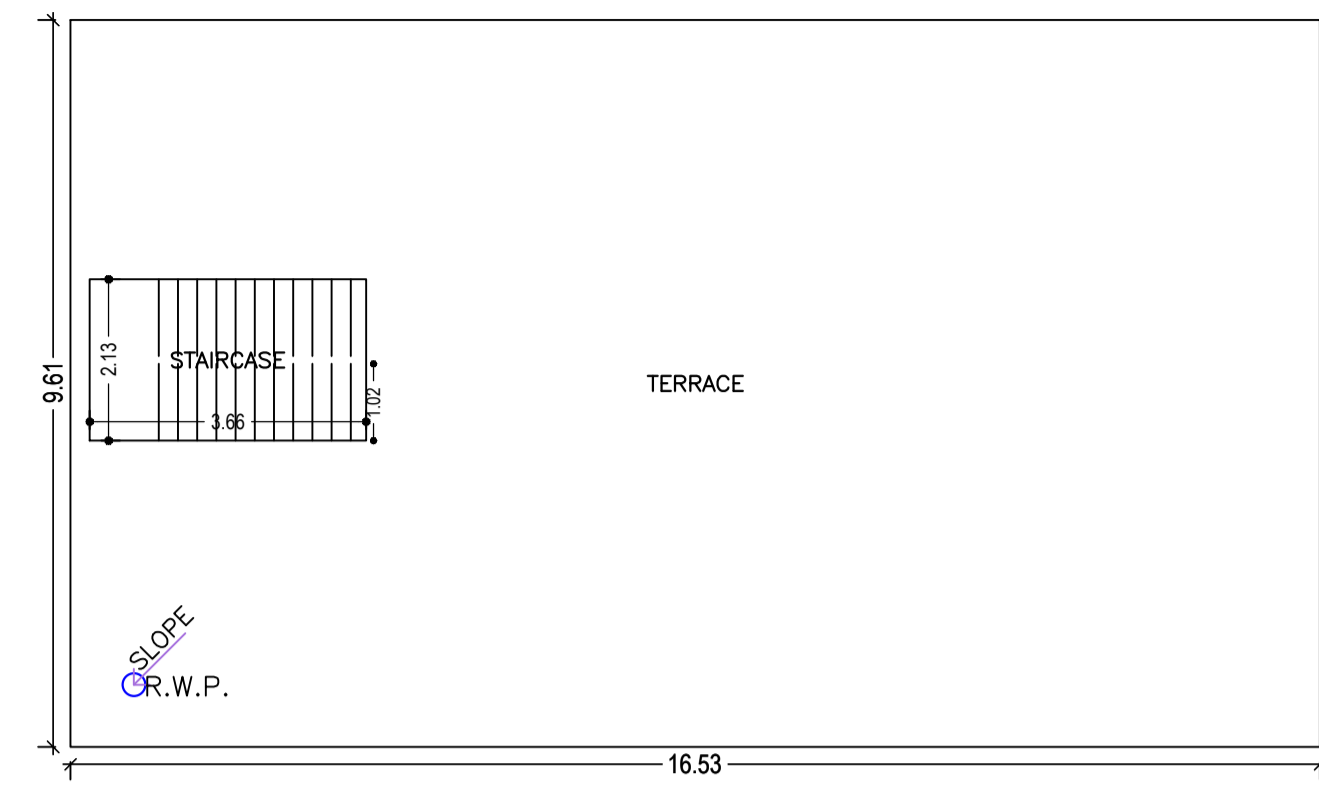

TERRACE FLOOR PLAN
(SCALE 1:100)

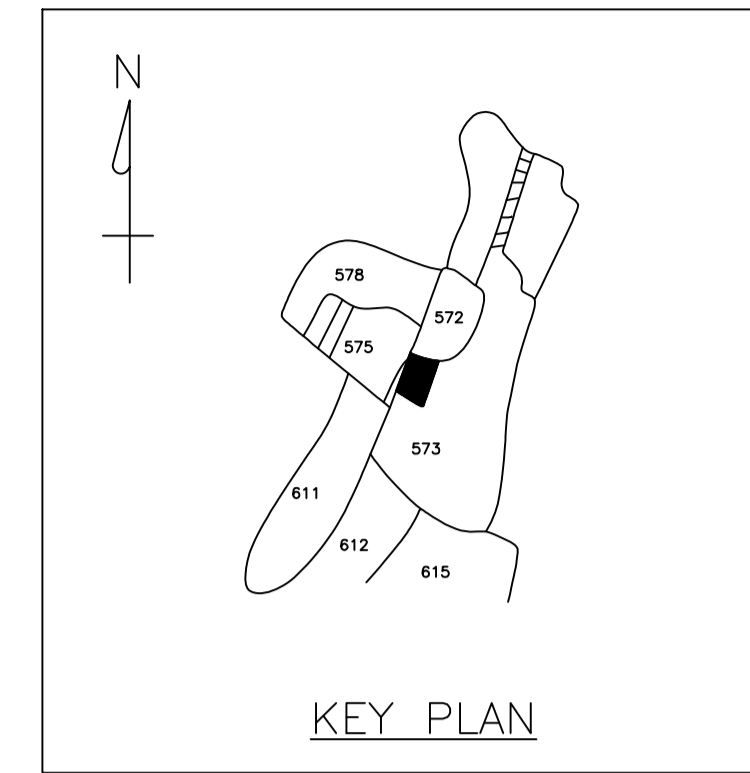

KEY PLAN

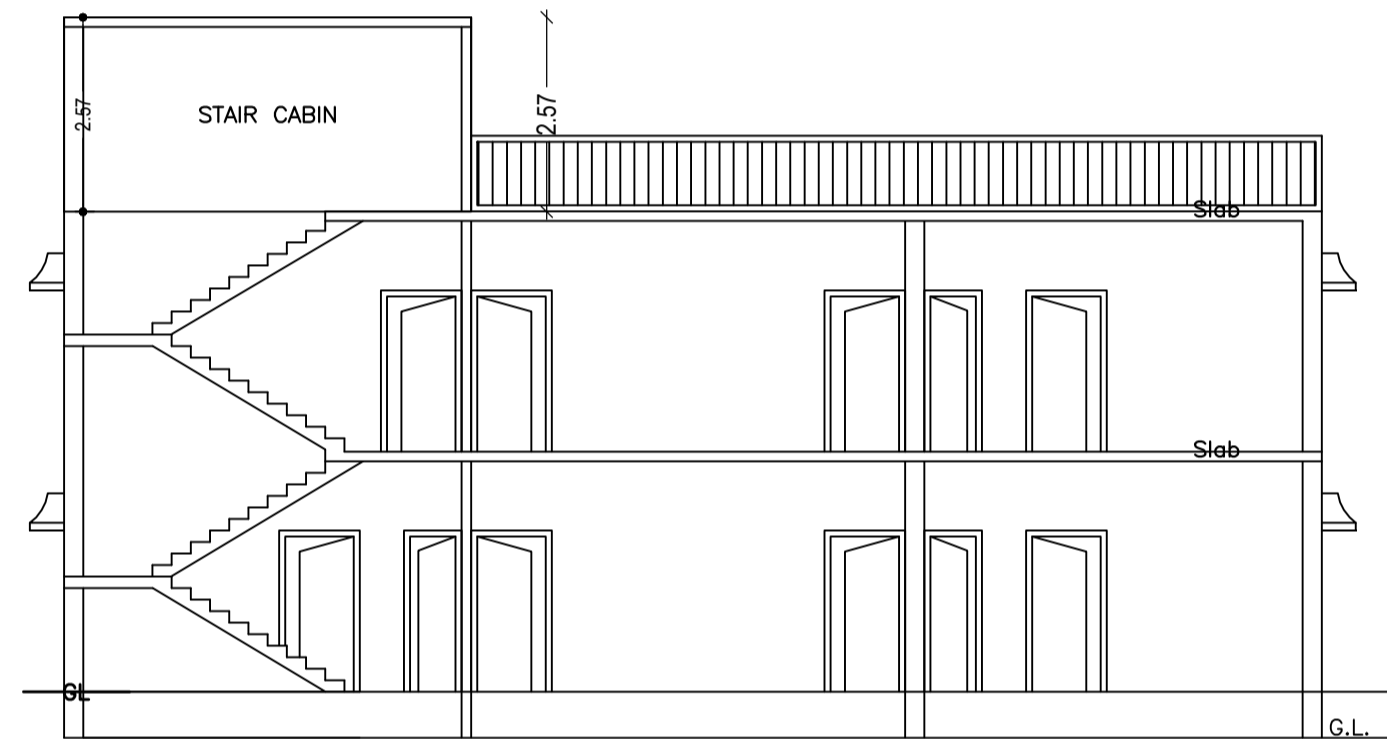

SECTION ON X-X

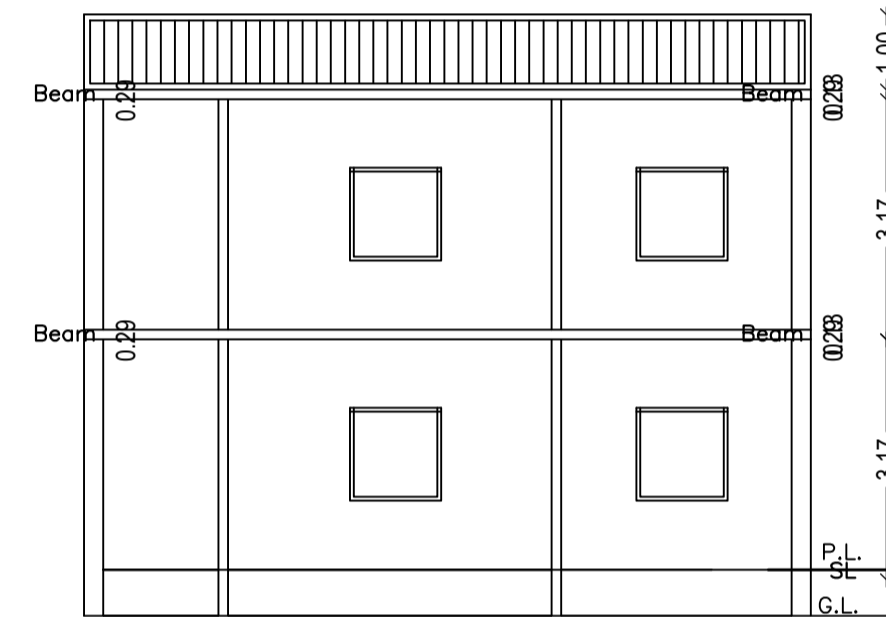

SECTION ON Y-Y

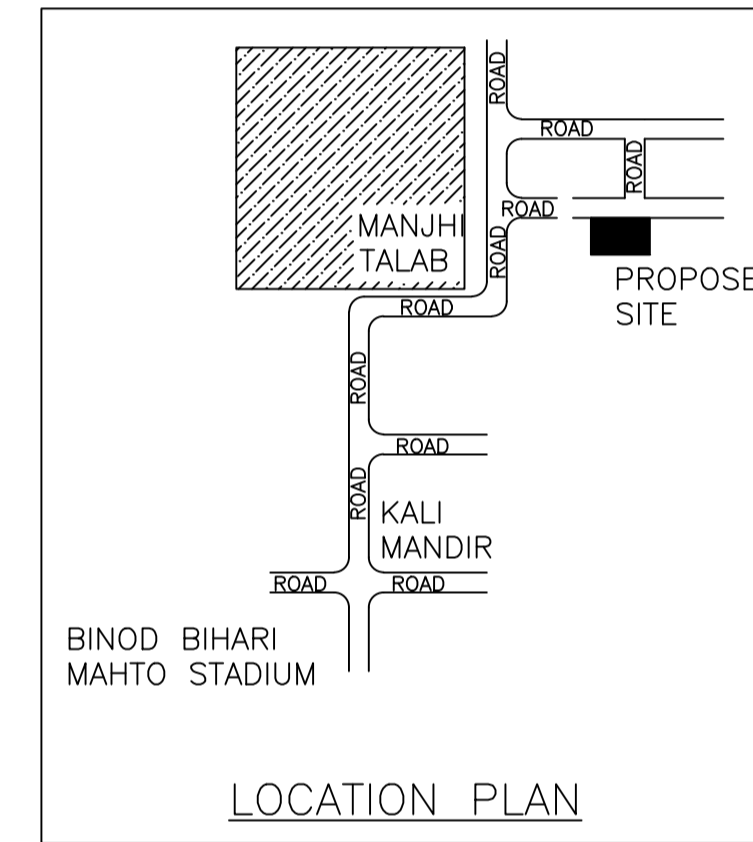

LOCATION PLAN

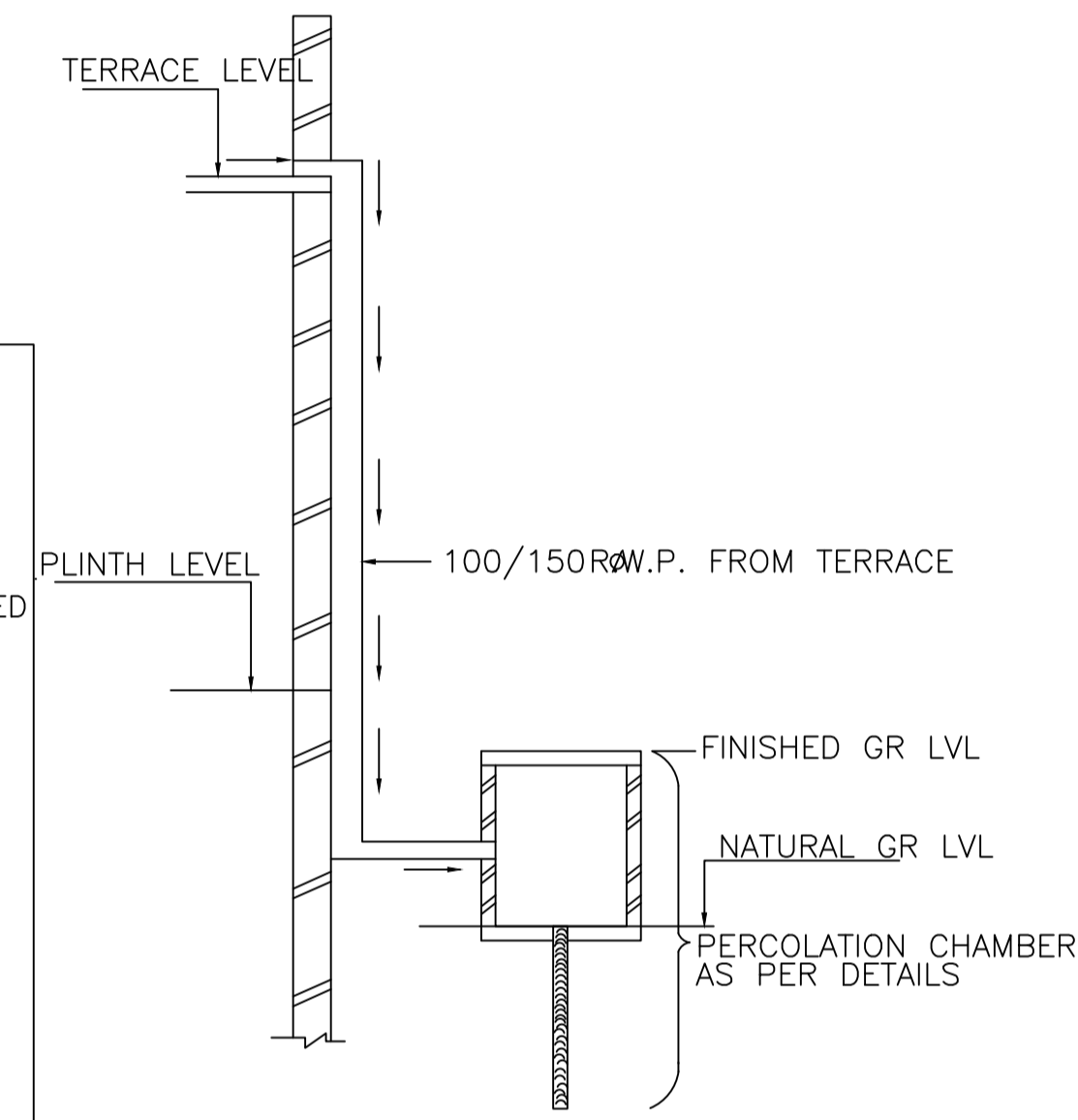

ROOF TOP RAIN WATER
COLLECTION SYSTEM

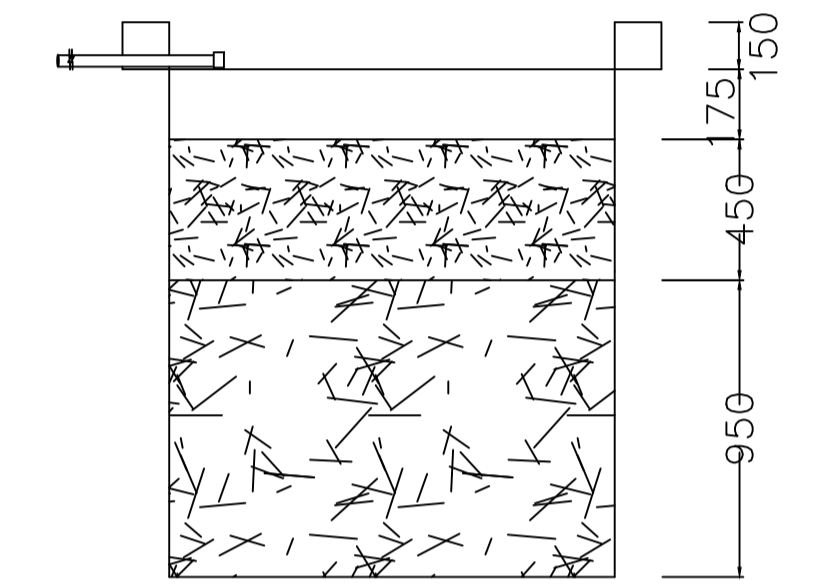

SECTION AT Y-Y

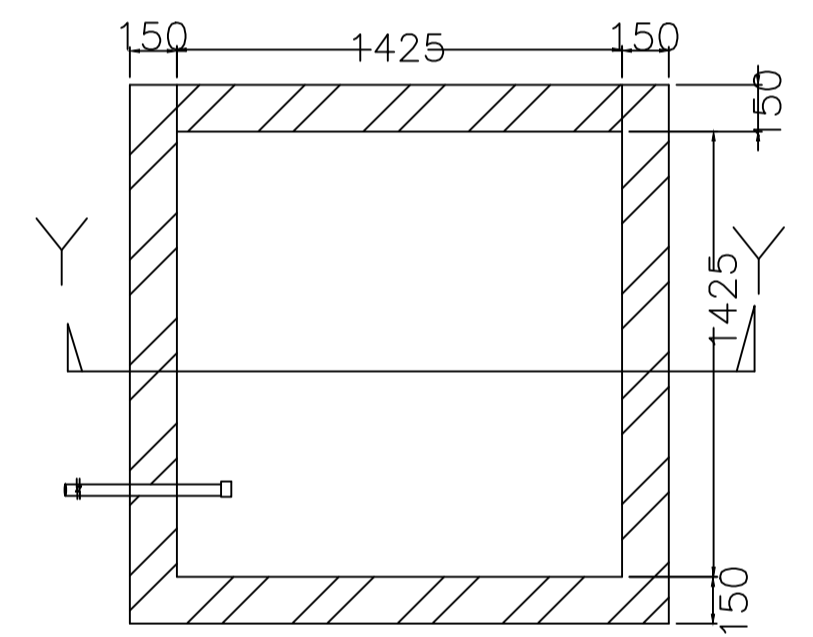

PLAN OF RECHARGE WELL
WATER HARVESTING

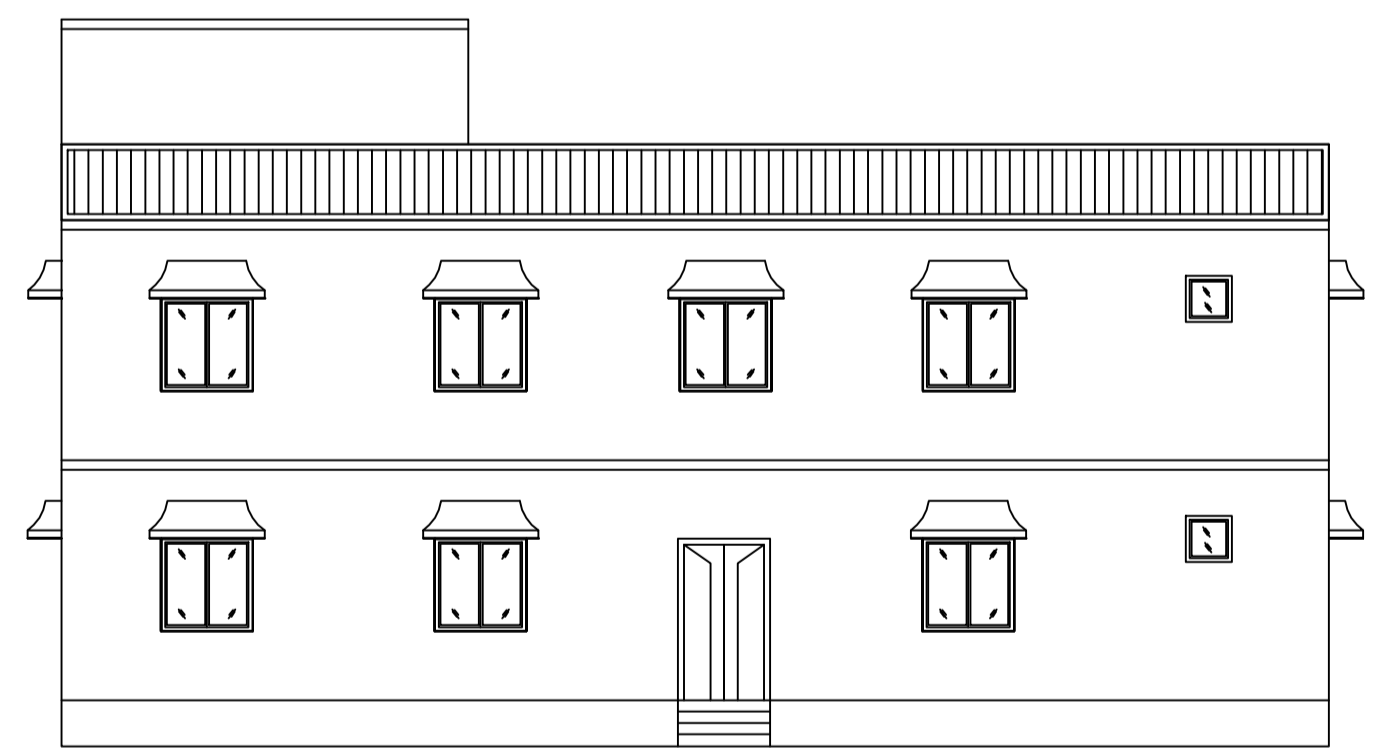

FRONT ELEVATION

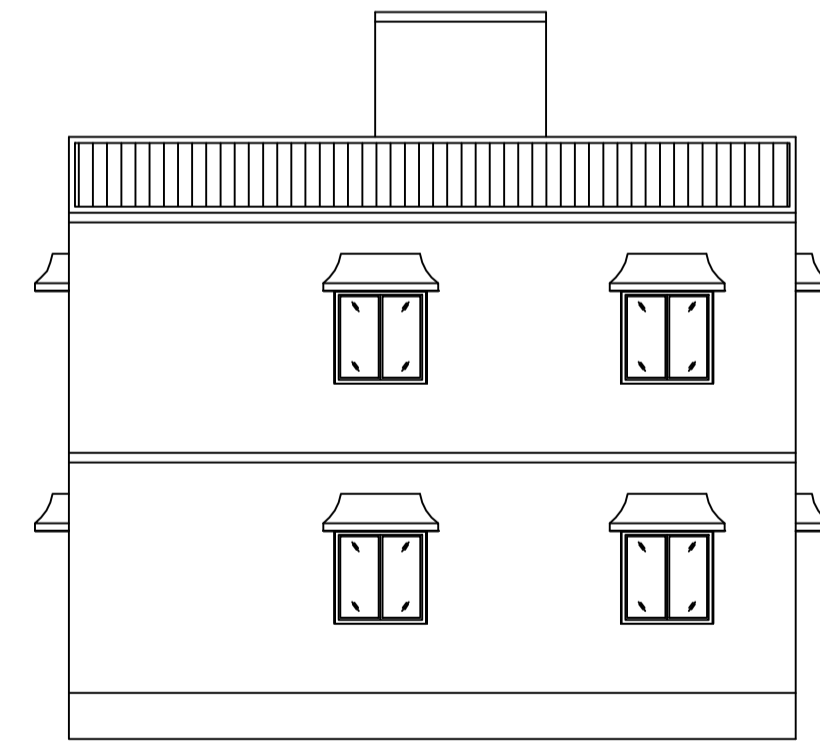

RIGHT SIDE ELEVATION

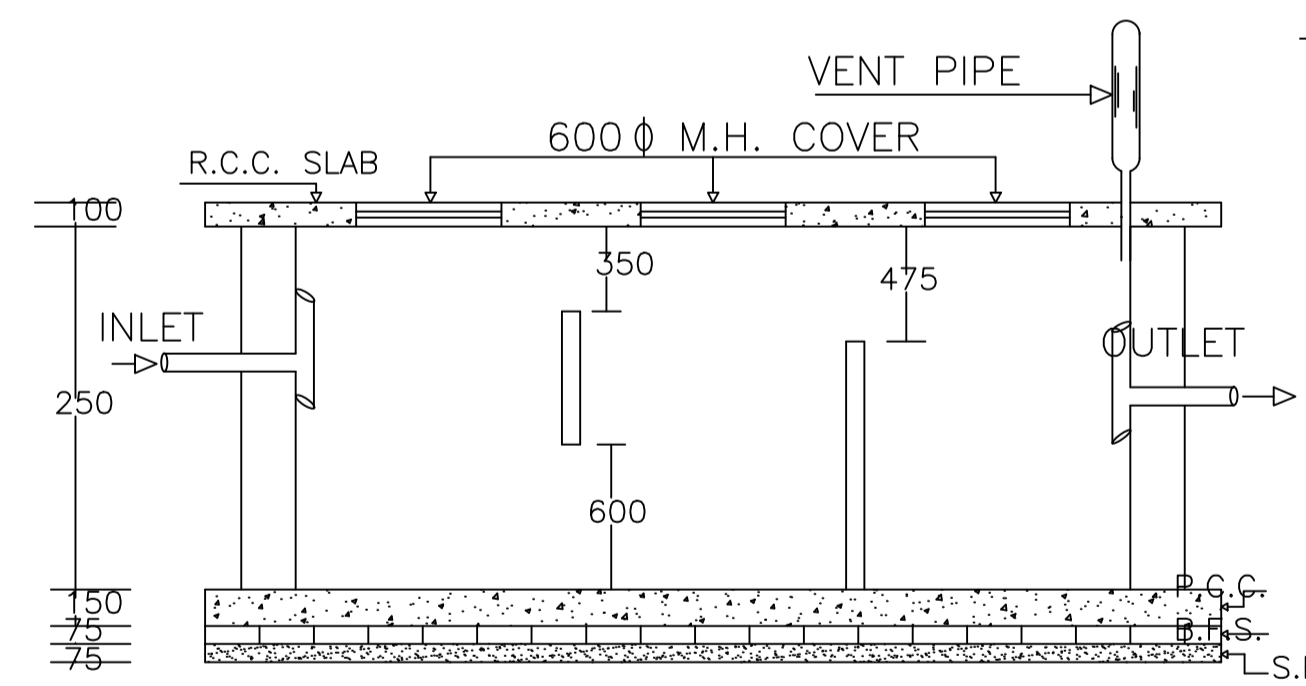

PLAN OF SEPTIC TANK

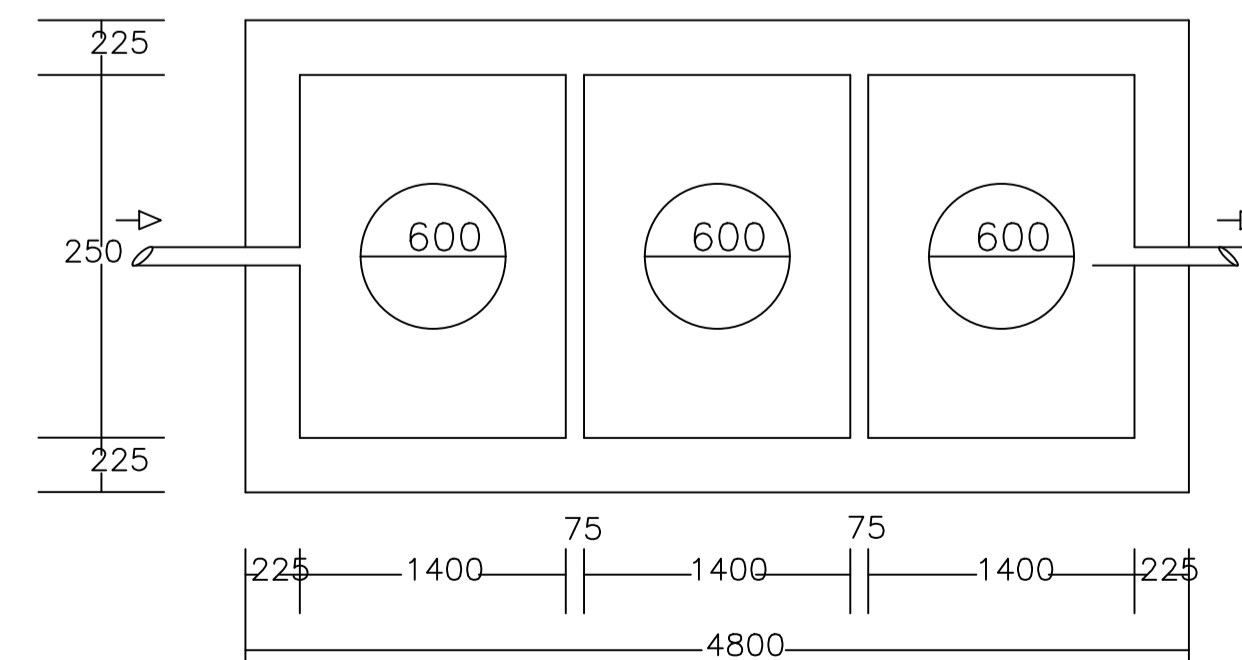

LTP NAME AND SIGNATURE SANJEEV KUMAR RAY DMC/ENG/0001/2019	STRUCTURAL ENG'S NAME AND SIGNATURE	BUILDER NAME AND SIGNATURE	DIGITAL SIGNATURE
--	-------------------------------------	----------------------------	-------------------