

Proposal Basic Information

Proposal File No.	DMC/BP/0269/W17/2021
Owner Name	1) ASHOK KUMAR 2) MAYA DEVI
Khata No	OLD - 48 , NEW- 601
Plot No	OLD - 208 , NEW - 91
Village Name	Panderpala
Use	Residential
SubUse	Bungalow/ Dwelling / Non Apartment

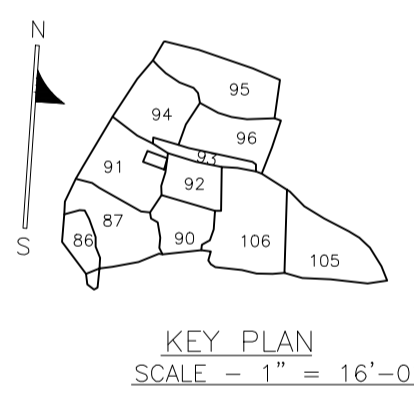
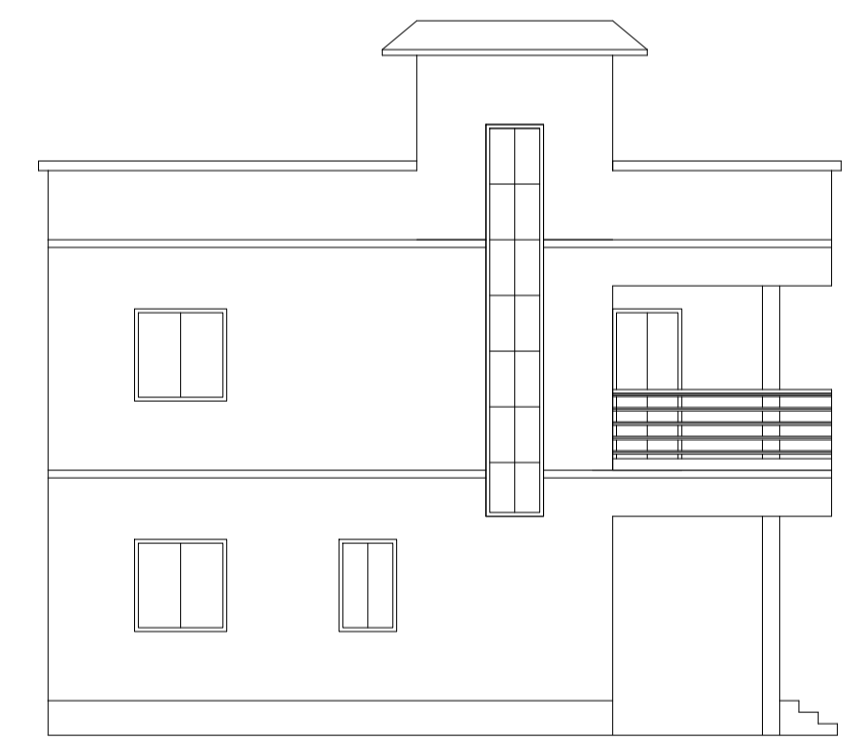
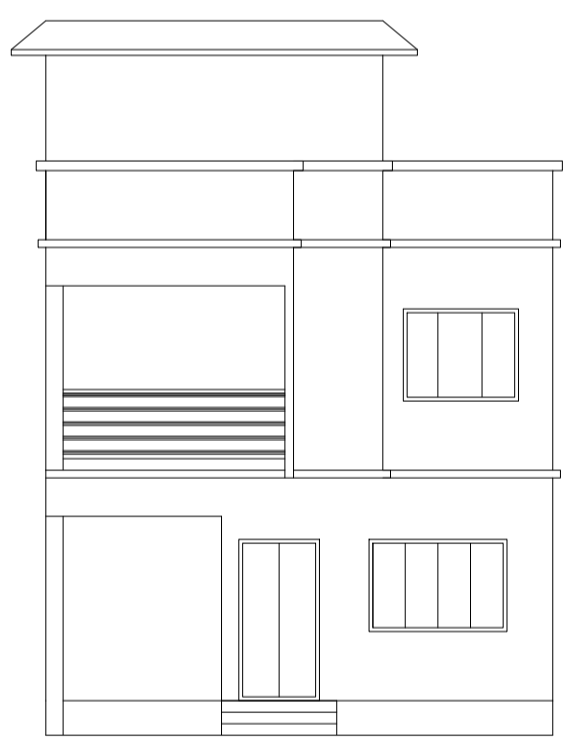
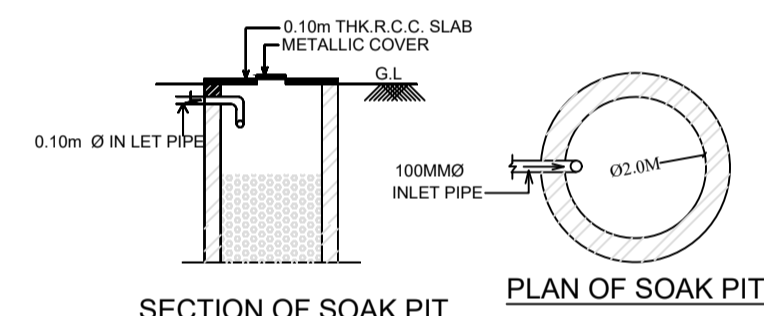
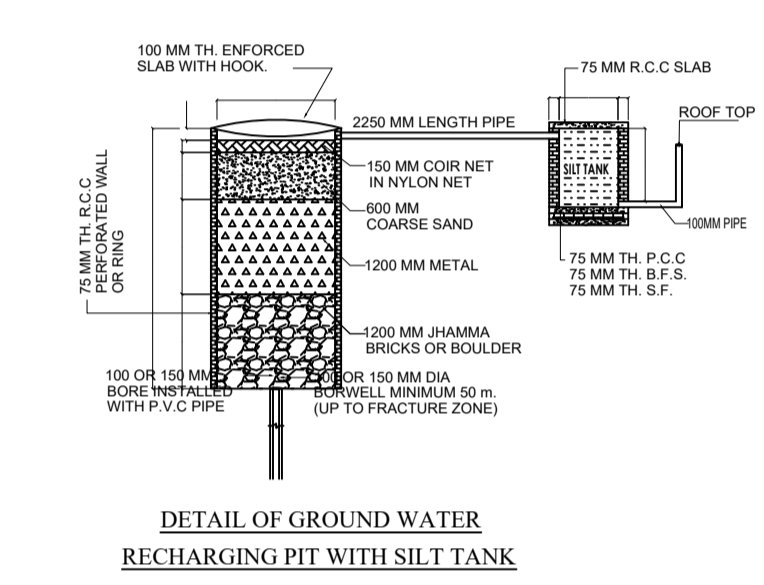
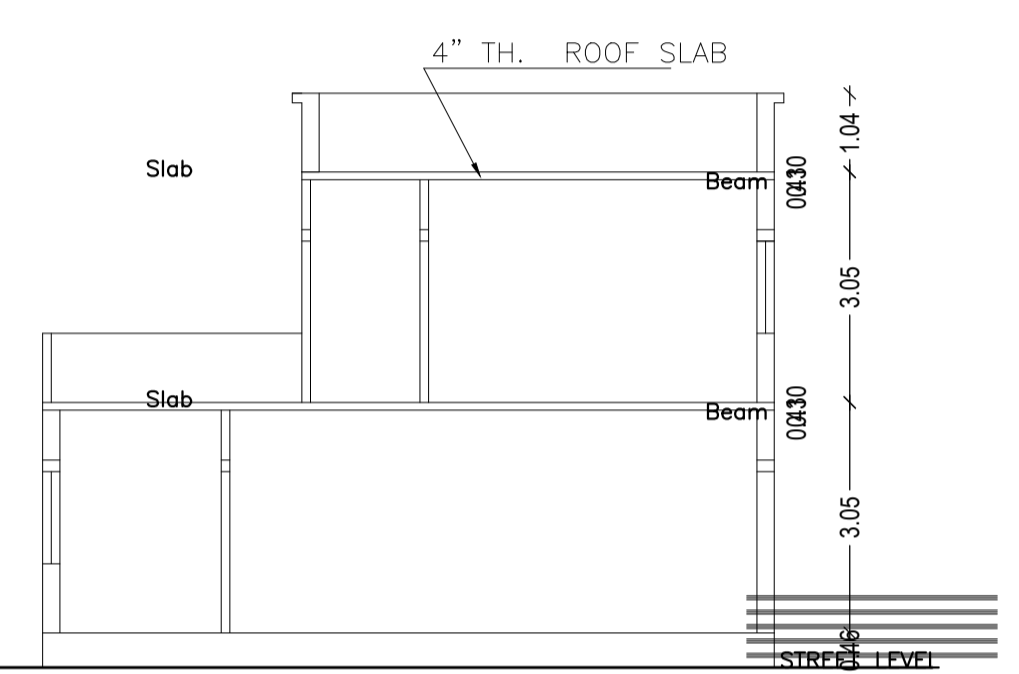
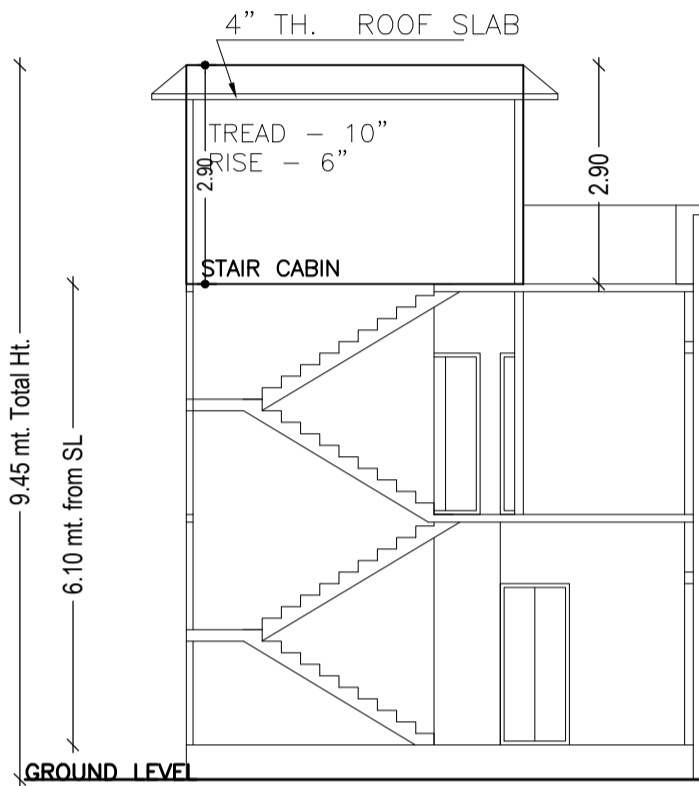
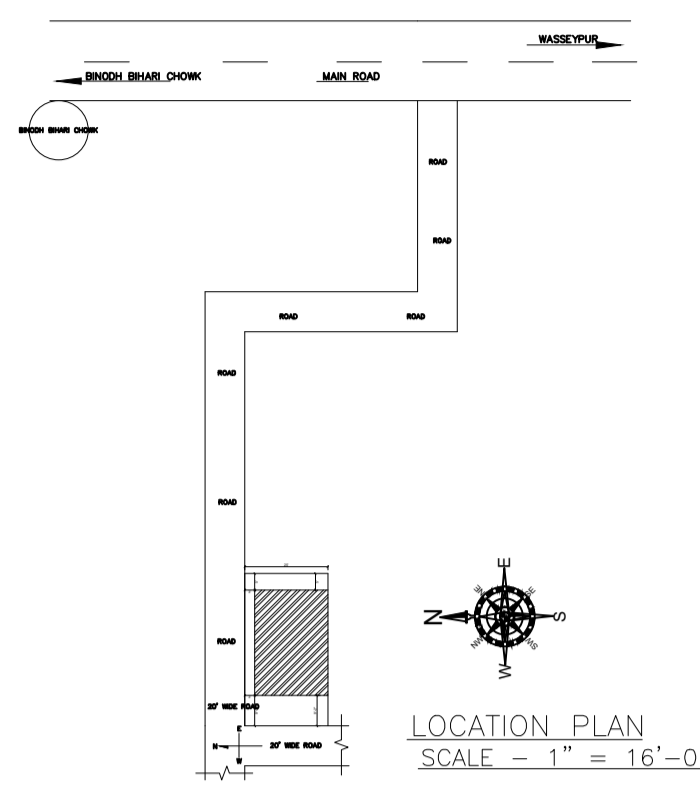
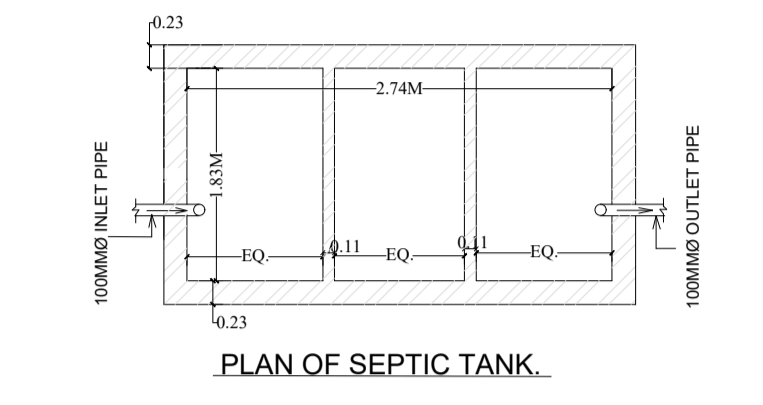
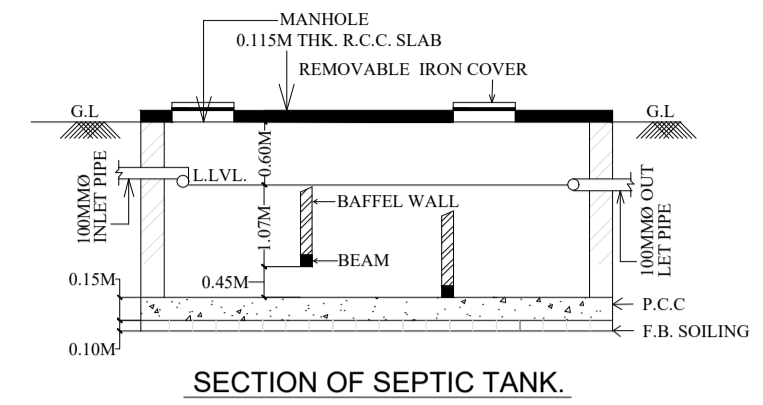
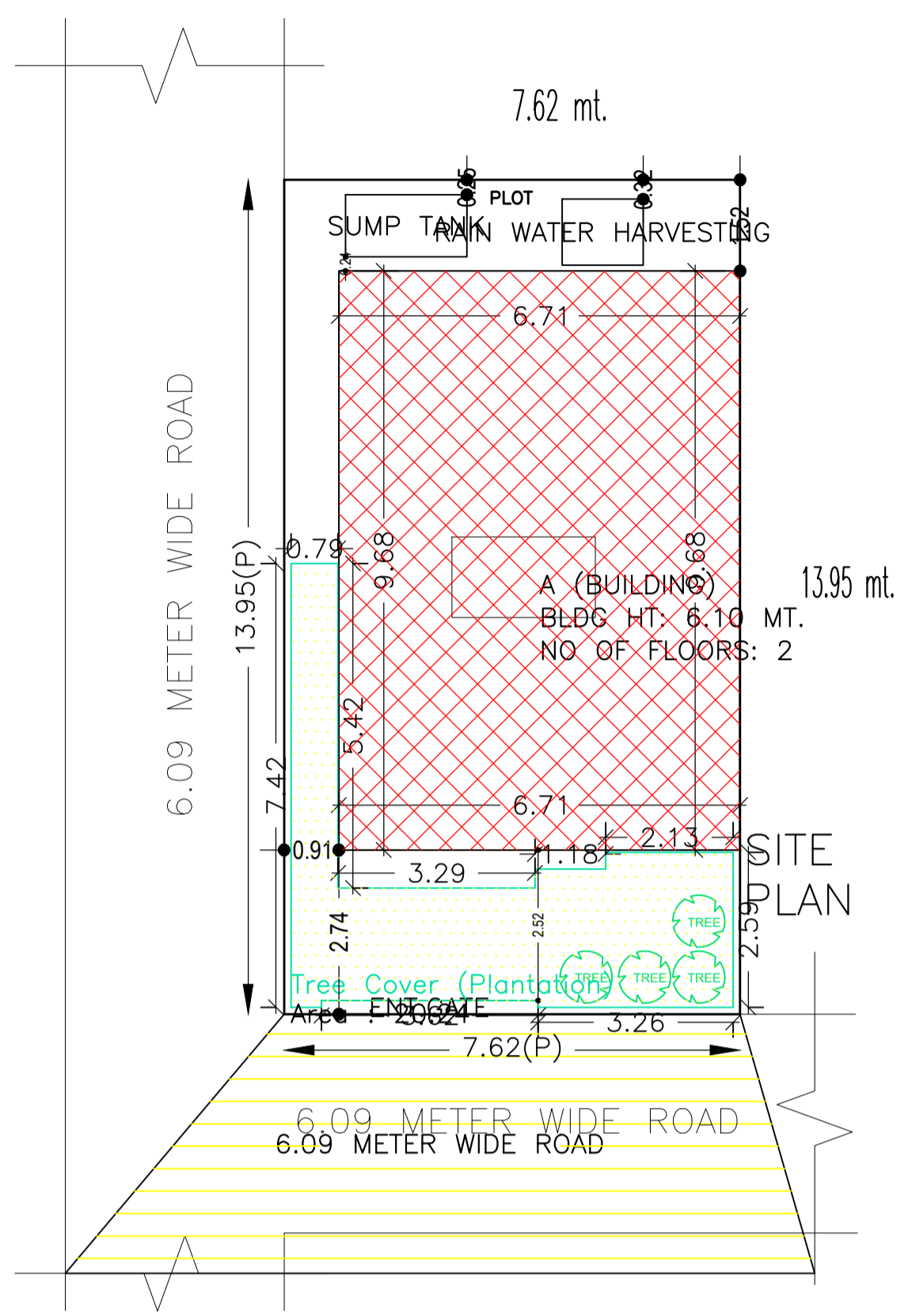
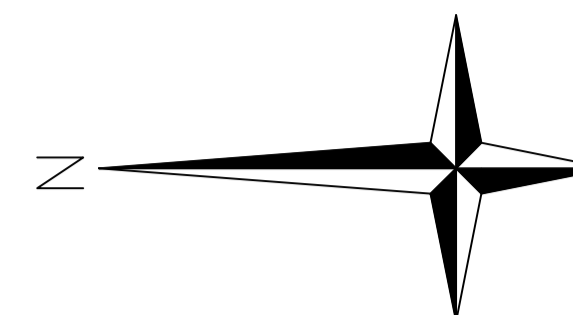

AREA STATEMENT	VERSION NO.: 1.0/61
DHANBAD MUNICIPAL CORPORATION	VERSION DATE: 16/10/2020
PROJECT DETAIL:	
Region: JHARKHAND URBAN LOCAL BODIES	Plot Use: Residential
District: DHANBAD	Plot SubUse: Bungalow/ Dwelling / Non Apartment
Authority: DHANBAD MUNICIPAL CORPORATION	Plot/Nearby/Religious/Structure: NA
Inward No: DMC/BP/0269/W17/2021	Plot/SubPlot No: OLD - 208 , NEW - 91
Application Type: General Proposal	North: Road Width - 6.09 M
Project Type: Building Permission	South: Plot No. - PART OF THIS PLOT
Nature of Development: New	East: Plot No. - NEW PLOT NO - 92
Location of Development Area: Old Area	West: Road Width - 6.09 M
AREA DETAILS:	
AREA OF PLOT (Minimum)	(A) 106.26 SQ.MT.
NET AREA OF PLOT(Gross Plot Area - Deduction from Gross Plot area)	(A-Deductions) 106.26
Deduction for Balance Plot Area(from Gross Plot Area)	
Common Plot	20.24
Total	20.24
BALANCE AREA OF PLOT(Net Plot Area - Recreational/Amenity space)	(A-Deductions) 86.03
PLOT AREA FOR COVERAGE(Net Plot Area)	(A-Deductions) 106.26
Plot Area for FAR (Net Plot Area + Road Widening Area)	(A-Deductions) 106.26
COVERAGE CHECK	
Permissible Coverage area (70.00 %)	74.38
Proposed Coverage Area (61.06 %)	64.89
Total Prop. Coverage Area (61.06 %)	64.89
Balance coverage area (8.93 %)	9.49
FAR CHECK	
Perm. FAR Area (1.80)	191.27
Total Perm. FAR area	191.27
Residential FAR	132.41
Proposed FAR Area	132.41
Total Proposed FAR Area	132.41
Consumed FAR (Factor)	1.25
Balance FAR Area	58.86
BUILT UP AREA CHECK	
Total Proposed BuiltUp Area	132.40
ARCHITECT (Regd)	MD IMRAN KHAN
ENGINEER (Regd)	
SUPERVISOR (Regd)	
OWNER (Regd)	1) ASHOK KUMAR 2) MAYA DEVI
DEVELOPMENT AUTHORITY LOCAL BODY	

COLOR INDEX	
PLOT BOUNDARY	Black
ABUTTING ROAD	Green
PROPOSED CONSTRUCTION	Red
COMMON PLOT	Yellow
ROAD WIDENING AREA	Blue
EXISTING (To be retained)	Orange
EXISTING (To be demolished)	Light Blue

Floor Name	Building Name A (BUILDING)		Total	
	Proposed Built Up Area (Sq.mt.)	Proposed FAR Area (Sq.mt.)	Total Proposed Built Up Area (Sq.mt.)	Total FAR Area (Sq.mt.)
Ground Floor	64.89	64.89	64.89	64.89
First Floor	67.51	67.51	67.51	67.51
Terrace Floor	0.00	0.00	0.00	0.00
Total:	132.40	132.40	132.40	132.40

FAR & Tenement Details (Table 4c-1)						
Building	No. of Same Bldg	Total Built Up Area (Sq.mt.)	Proposed FAR Area (Sq.mt.)	Total FAR Area (Sq.mt.)	Total Consumed Additional FAR Area (Sq.mt.)	Tnmt (No.)
A (BUILDING)	1	132.40	132.40	132.40	132.40	01
Grand Total:	1	132.40	132.40	132.40	132.40	01

Building :A (BUILDING)					
Floor Name	Total Built Up Area (Sq.mt.)	Proposed FAR Area (Sq.mt.)	Total FAR Area (Sq.mt.)	Total Consumed Additional FAR Area (Sq.mt.)	Tnmt (No.)
Ground Floor	64.89	64.89	64.89	64.89	01
First Floor	67.51	67.51	67.51	67.51	00
Terrace Floor	0.00	0.00	0.00	0.00	00
Total:	132.40	132.40	132.40	132.40	01
Total Number of Same Buildings	1	132.40	132.40	132.40	01

Building USE/SUBUSE Details

Building Name	Building Use	Building SubUse	Building Structure
A (BUILDING)	Residential	Bungalow/ Dwelling / Non Apartment	Non-Highrise

UnitBUA Table for Building :A (BUILDING)

FLOOR	Name	UnitBUA Type	UnitBUA Area	Carpet Area	No. of Rooms	No. of Tenement
GROUND FLOOR PLAN	SPLIT FALT - A	FLAT	132.41	132.30	5	1
FIRST FLOOR PLAN	SPLIT FALT - A	FLAT	0.00	0.00	7	0
Total:			132.41	132.30	12	1

SCHEDULE OF DOOR:

BUILDING NAME	NAME	LENGTH	HEIGHT	NOS
A (BUILDING)	D2	0.84	2.10	03
A (BUILDING)	D1	0.91	2.10	01
A (BUILDING)	D1	0.95	2.10	05
A (BUILDING)	D	1.07	2.10	03

SCHEDULE OF WINDOW/VENTILATION:

BUILDING NAME	NAME	LENGTH	HEIGHT	NOS
A (BUILDING)	V	0.76	1.20	03
A (BUILDING)	W1	1.22	1.20	09
A (BUILDING)	W2	1.22	1.20	01
A (BUILDING)	W	1.83	1.20	01

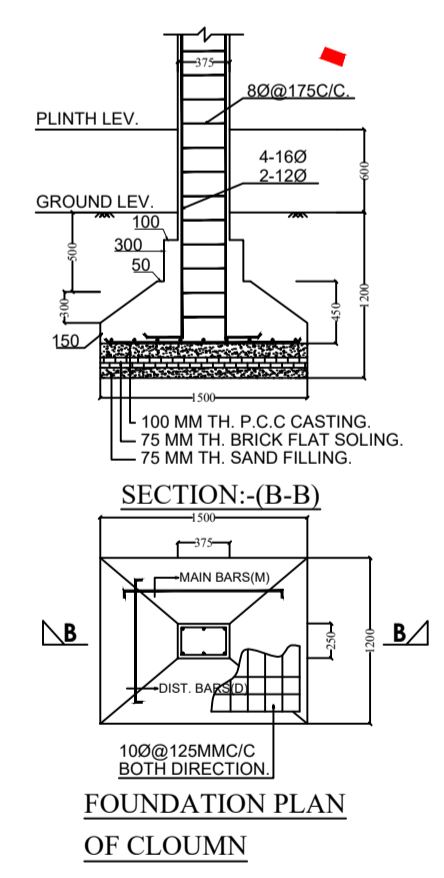
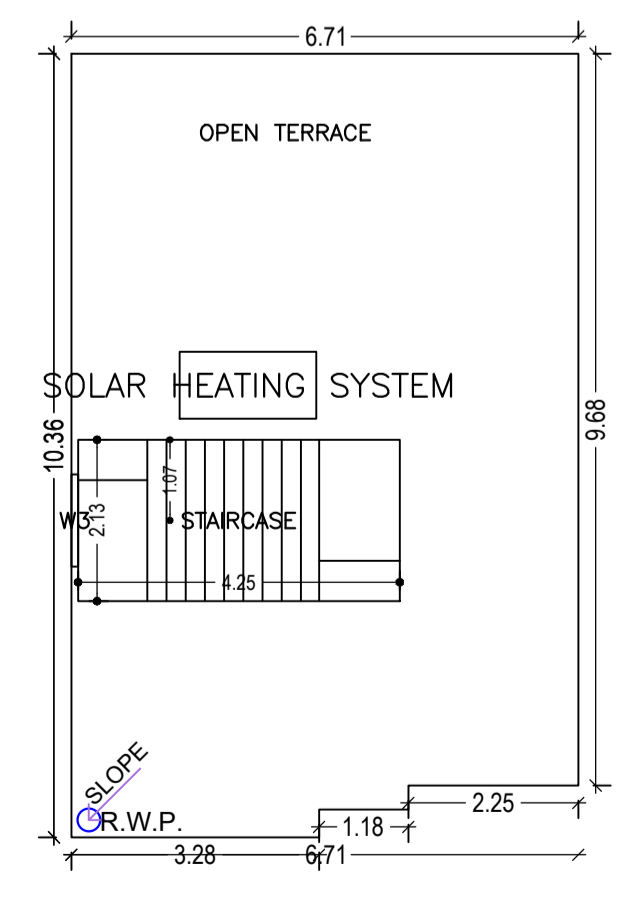
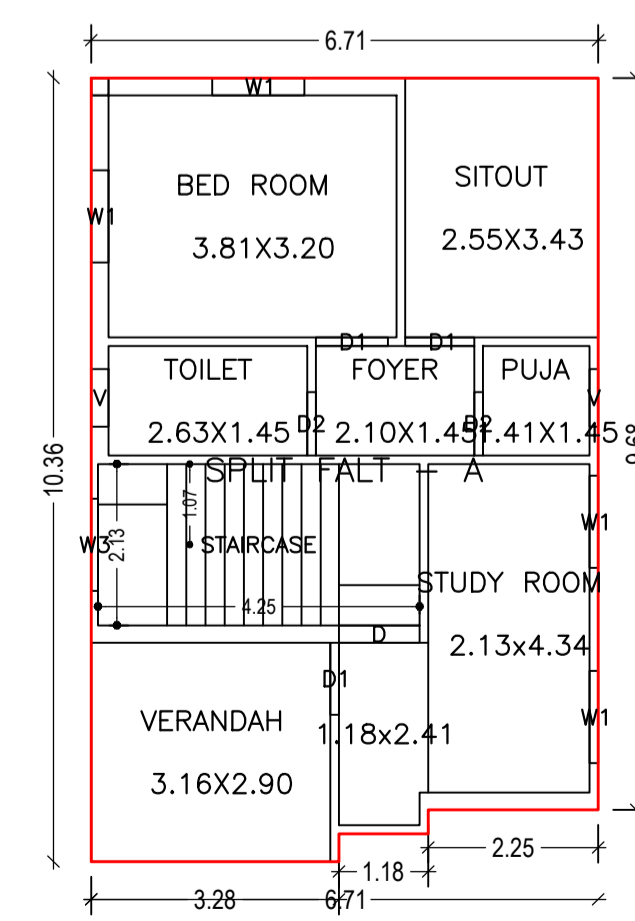
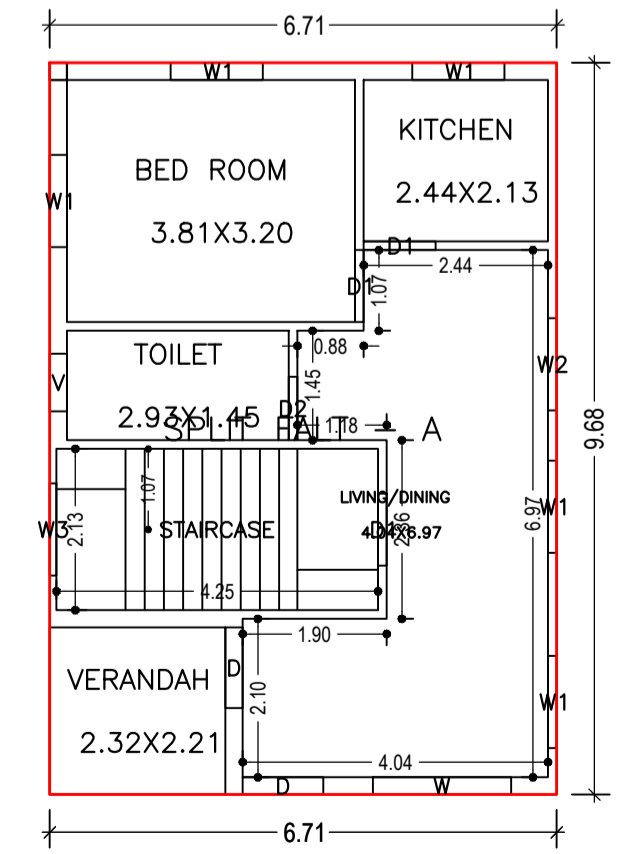

LTP NAME AND SIGNATURE	STRUCTURAL ENG'S NAME AND SIGNATURE	BUILDER NAME AND SIGNATURE	DIGITAL SIGNATURE
MD IMRAN KHAN DMC/ENG/0008/2020			