

Proposal Basic Information	
Proposal File No.	DMC/BP/0115/W22/2022
Owner Name	KRISHNA VISHWAKARMA
Khata No	OLD-32, NEW-240
Plot No	OLD-726, NEW-774
Village Name	Bhelaland
Use	Residential
SubUse	Bungalow/ Dwelling / Non Apartment

AREA STATEMENT		VERSION NO.: 1.0.62
DHANBAD MUNICIPAL CORPORATION		VERSION DATE: 16/10/2020
PROJECT DETAIL:		
Region: JHARKHAND URBAN LOCAL BODIES	Plot Use: Residential	
District: DHANBAD	Plot SubUse: Bungalow/ Dwelling / Non Apartment	
Authority: DHANBAD MUNICIPAL CORPORATION	PlotNearby/ReligiousStructure: NA	
Inward No: DMC/BP/0115/W22/2022	Plot/SubPlot No: OLD-726, NEW-774	
Application Type: General Proposal	North: Road Width - 4.57	
Project Type: Building Permission	South: Road Width - 3.05	
Nature of Development: New	East: Road Width - 3.05	
Location of Development Area: Old Area	West: Plot No. - 726 PART	
AREA DETAILS:		
AREA OF PLOT (Minimum)	(A)	SQ.MT. 314.90
NET AREA OF PLOT(Gross Plot Area - Deduction from Gross Plot area)	(A-Deductions)	314.90
Deduction for Balance Plot Area(from Gross Plot Area)		
Common Plot		16.28
Total		16.28
BALANCE AREA OF PLOT(Net Plot Area - Recreational/Amenity space)	(A-Deductions)	298.61
PLOT AREA FOR COVERAGE(Net Plot Area)	(A-Deductions)	314.90
Plot Area for FAR (Net Plot Area + Road Widening Area)	(A-Deductions)	314.90
COVERAGE CHECK		
Permissible Coverage area ( 60.00 % )		188.94
Proposed Coverage Area ( 47.14 % )		148.45
Total Prop. Coverage Area ( 47.14 % )		148.45
Balance coverage area ( 12.86 % )		40.49
FAR CHECK		
Perm. FAR Area ( 1.80 )		566.82
Total Perm. FAR area		566.82
Residential FAR		296.90
Proposed FAR Area		296.90
Total Proposed FAR Area		296.90
Consumed FAR (Factor)		0.94
Balance FAR Area		269.92
BUILT UP AREA CHECK		
Total Proposed BuiltUp Area		296.90
ARCHITECT (Regd)		SANJEEV KUMAR RAY
ENGINEER (Regd)		
SUPERVISOR (Regd)		
OWNER (Regd)		KRISHNA VISHWAKARMA
DEVELOPMENT AUTHORITY		LOCAL BODY

COLOR INDEX	
PLOT BOUNDARY	[Red Line]
ABUTTING ROAD	[Green Line]
PROPOSED CONSTRUCTION	[Yellow Line]
COMMON PLOT	[Blue Line]
ROAD WIDENING AREA	[Orange Line]
EXISTING (To be retained)	[Light Blue Line]
EXISTING (To be demolished)	[Light Yellow Line]

Buildingwise Floor FAR Details				
Floor Name	Building Name A (A)		Total	
	Proposed Built Up Area (Sq.mt.)	Proposed FAR Area (Sq.mt.)	Total Proposed Built Up Area (Sq.mt.)	Total FAR Area (Sq.mt.)
Ground Floor	148.45	148.45	148.45	148.45
First Floor	148.45	148.45	148.45	148.45
Terrace Floor	0.00	0.00	0.00	0.00
Total:	296.90	296.90	296.90	296.90

Building USE/SUBUSE Details			
Building Name	Building Use	Building SubUse	Building Structure
A (A)	Residential	Residential Bldg/Apartment	Non-Highrise

FAR & Tenement Details (Table 4c-1)						
Building	No. of Same Bldg	Total Built Up Area (Sq.mt.)	Proposed FAR Area (Sq.mt.) Res.	Total FAR Area (Sq.mt.)	Total Consumed Additional FAR Area (Sq.mt.)	Tnmt (No.)
A (A)	1	296.90	296.90	296.90	296.90	01
Grand Total:	1	296.90	296.90	296.90	296.90	01

UnitBUA Table for Building :A (A)						
FLOOR	Name	UnitBUA Type	UnitBUA Area	Carpet Area	No. of Rooms	No. of Tenement
GROUND FLOOR PLAN	SPLIT A	FLAT	296.90	296.81	12	1
FIRST FLOOR PLAN	SPLIT A	FLAT	0.00	0.00	12	0
Total:	-	-	296.90	296.81	24	1

SCHEDULE OF DOOR:				
BUILDING NAME	NAME	LENGTH	HEIGHT	NOS
A (A)	D	0.76	2.10	04
A (A)	D	0.91	2.10	06
A (A)	D	1.07	2.10	10
A (A)	D	1.17	2.10	02
A (A)	D	1.22	2.10	02

SCHEDULE OF WINDOW/VENTILATION:				
BUILDING NAME	NAME	LENGTH	HEIGHT	NOS
A (A)	V	0.61	1.20	06
A (A)	W	1.22	1.20	20

Building :A (A)					
Floor Name	Total Built Up Area (Sq.mt.)	Proposed FAR Area (Sq.mt.) Res.	Total FAR Area (Sq.mt.)	Total Consumed Additional FAR Area (Sq.mt.)	Tnmt (No.)
Ground Floor	148.45	148.45	148.45	148.45	01
First Floor	148.45	148.45	148.45	148.45	00
Terrace Floor	0.00	0.00	0.00	0.00	00
Total:	296.90	296.90	296.90	296.90	01
Total Number of Same Buildings :	1				
Total :	296.90	296.90	296.90	296.90	01

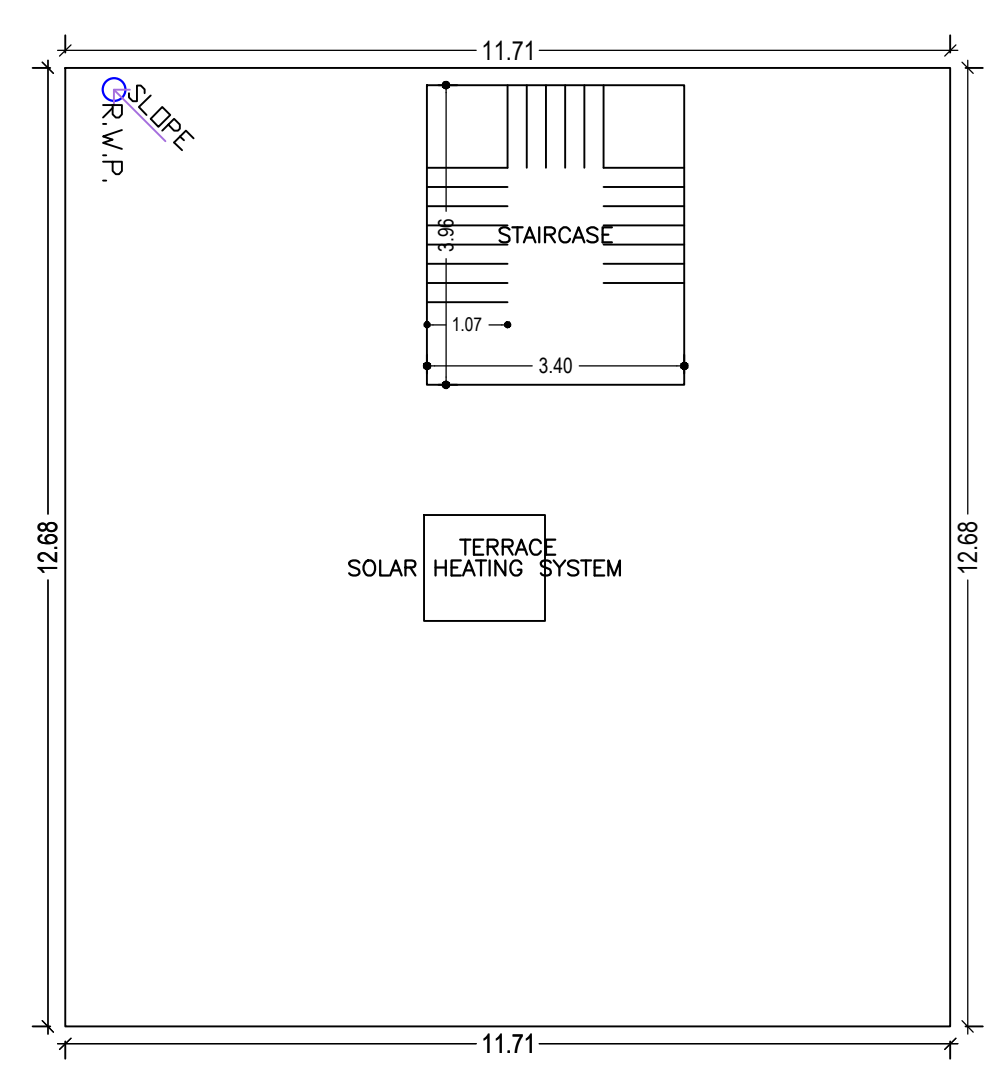
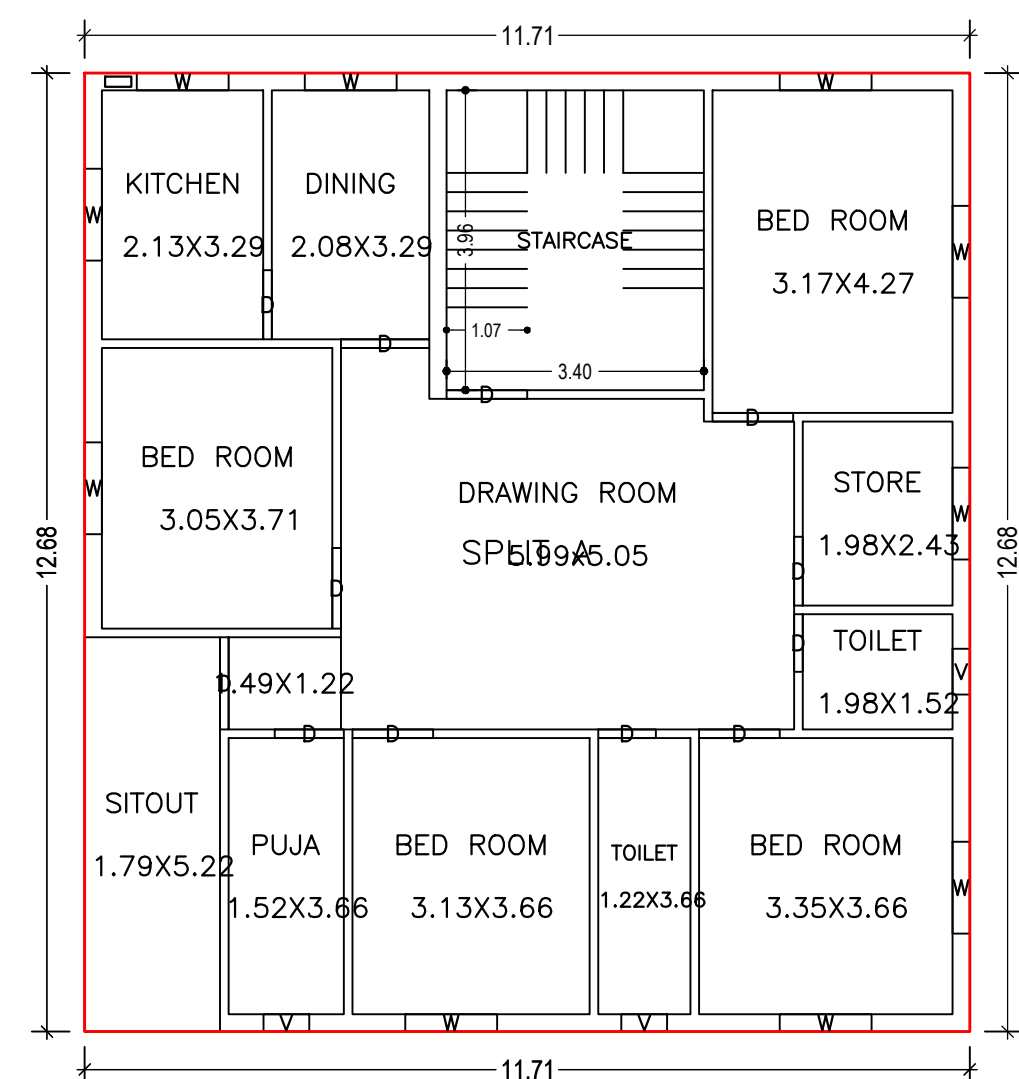
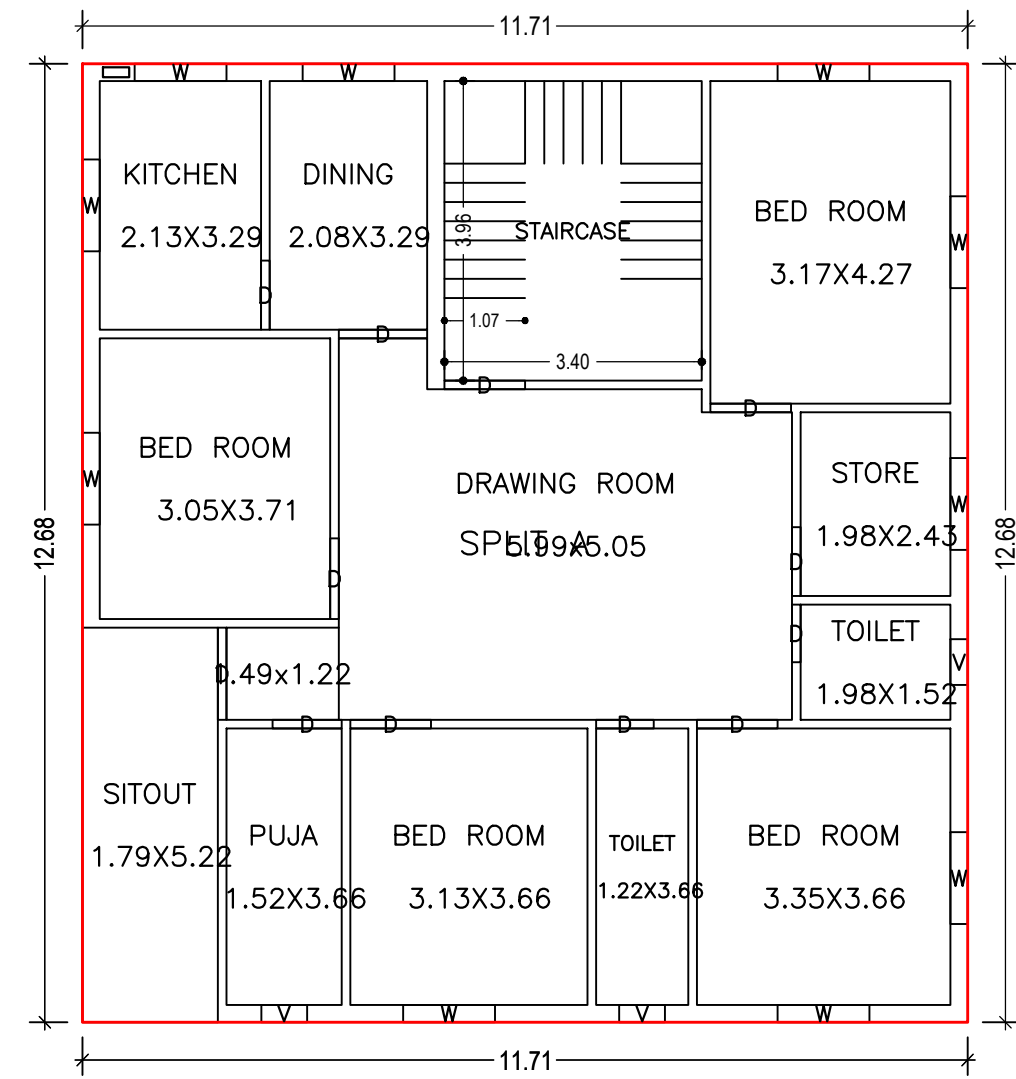

LTP NAME AND SIGNATURE	STRUCTURAL ENG'S NAME AND SIGNATURE	BUILDER NAME AND SIGNATURE	DIGITAL SIGNATURE
SANJEEV KUMAR RAY DMC/ENG/0001/2019			

Proposal Basic Information	
Proposal File No.	DMC/BP/0115/W22/2022
Owner Name	KRISHNA VISHWAKARMA
Khata No	OLD-32, NEW-240
Plot No	OLD-726, NEW-774
Village Name	Bhelaland
Use	Residential
SubUse	Bungalow/ Dwelling / Non Apartment

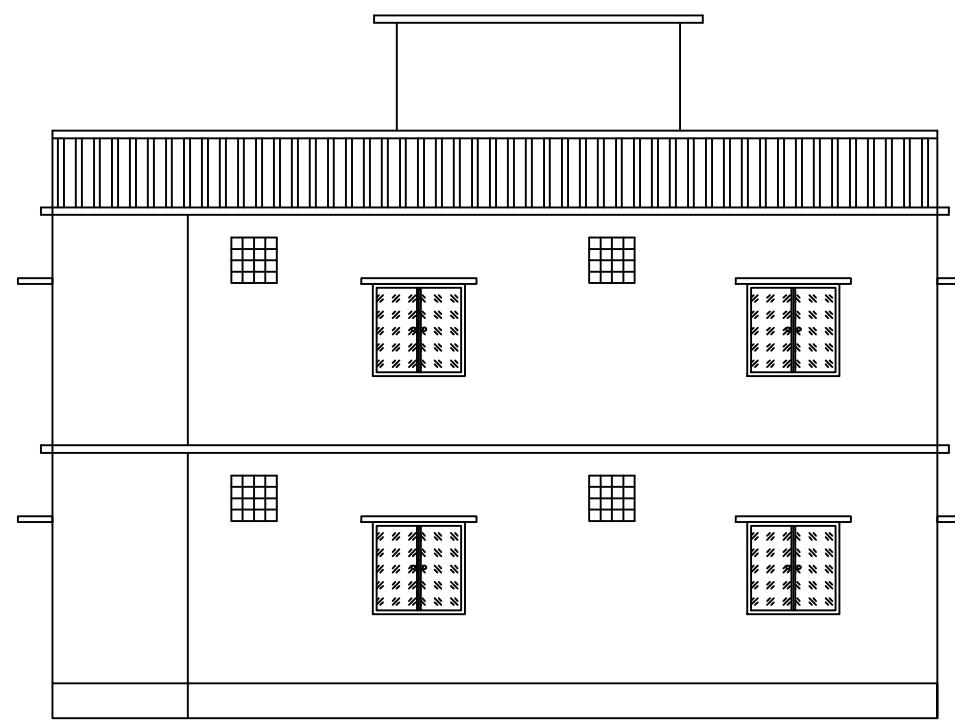
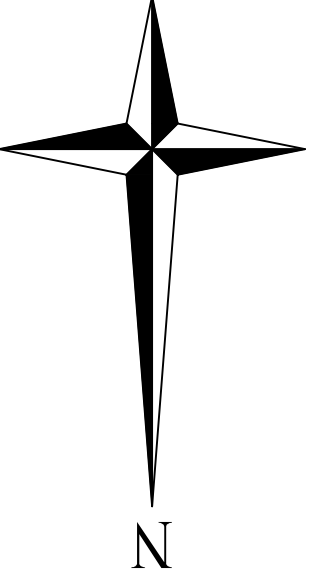

FRONT ELEVATION  
SCALE - 1:100

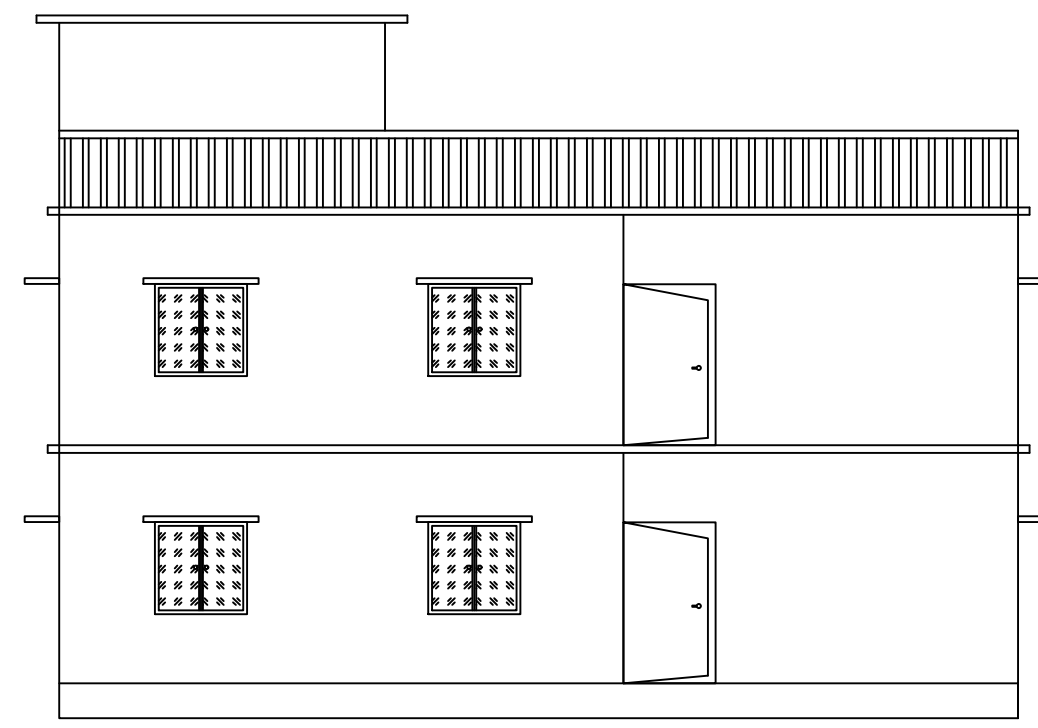

LEFT SIDE ELEVATION  
SCALE - 1:100

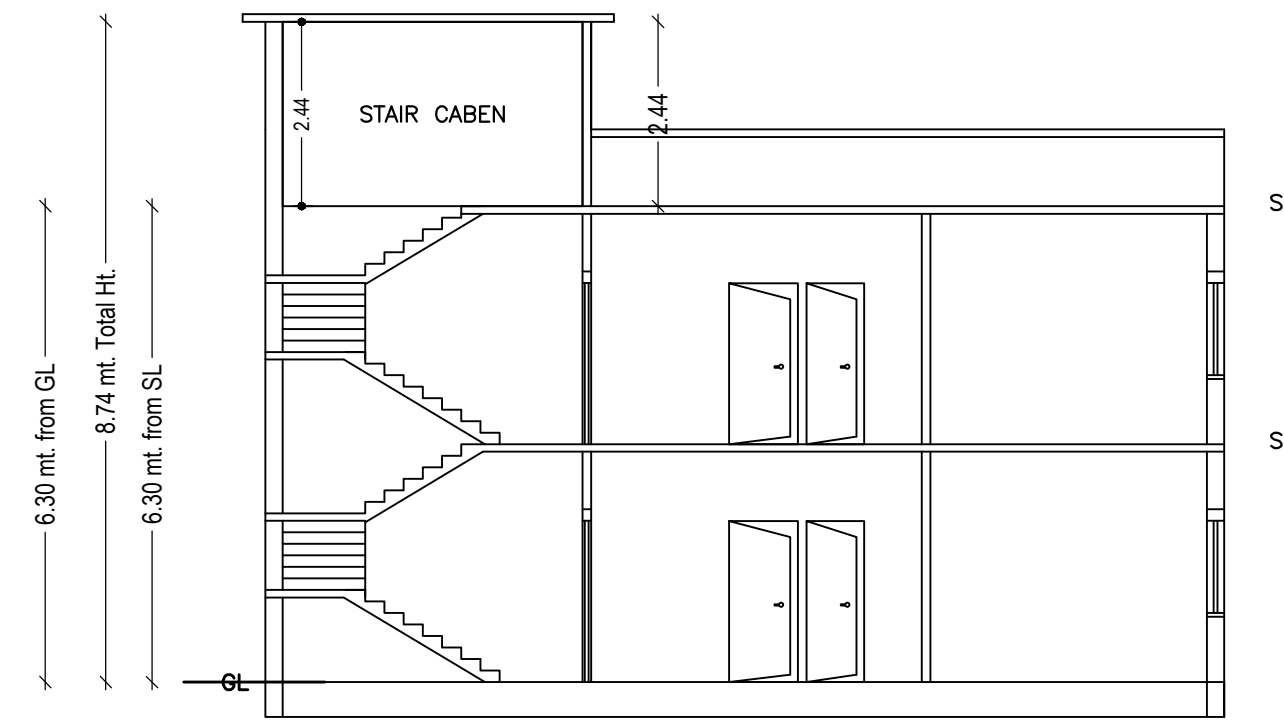

SECTION ON 'A-A'  
SCALE - 1:100

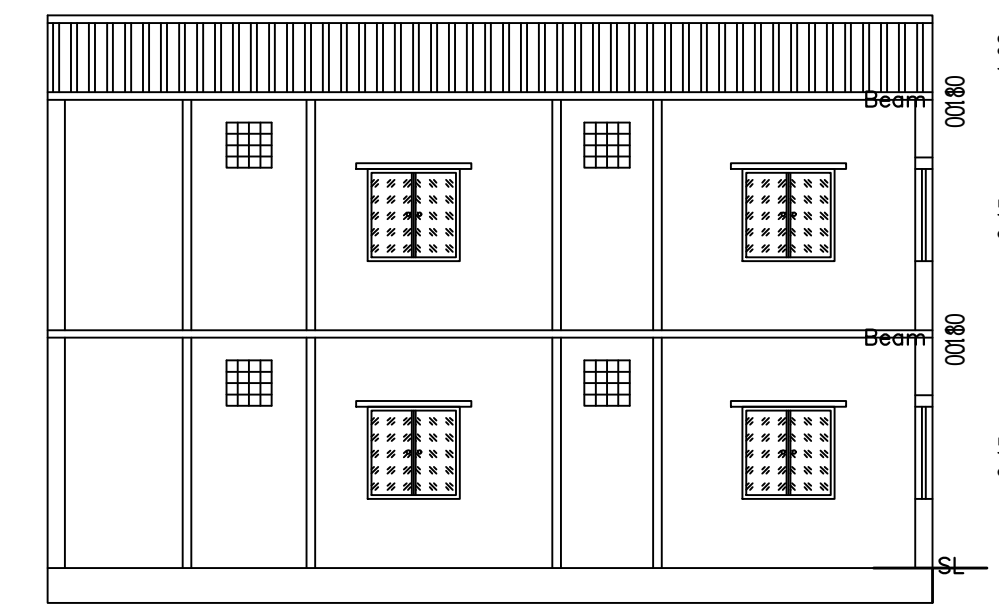

SECTION ON 'B-B'  
SCALE - 1:100

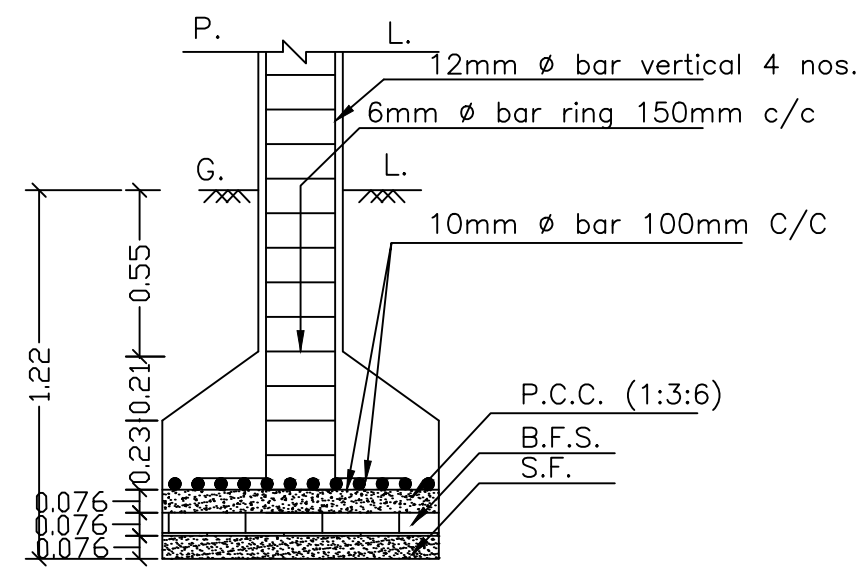

SECTION ON - ZZ  
SCALE - 1:25

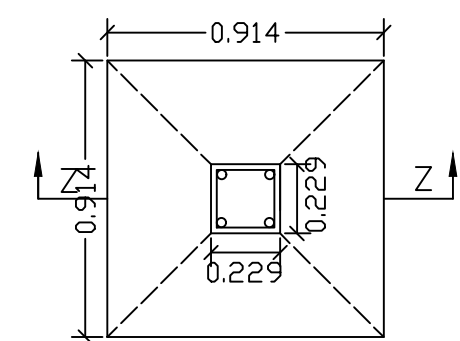

PLAN  
DETAILS OF COLUMN FOOTING  
SCALE - 1:25

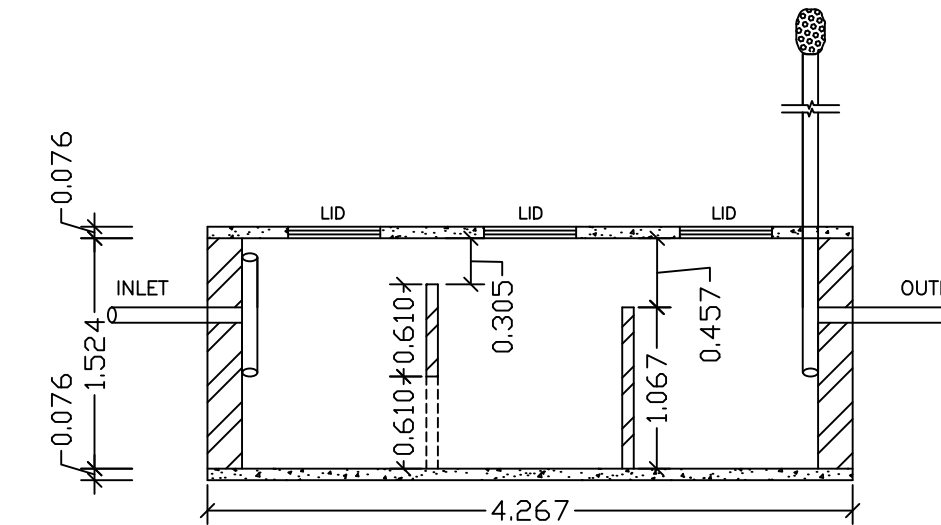
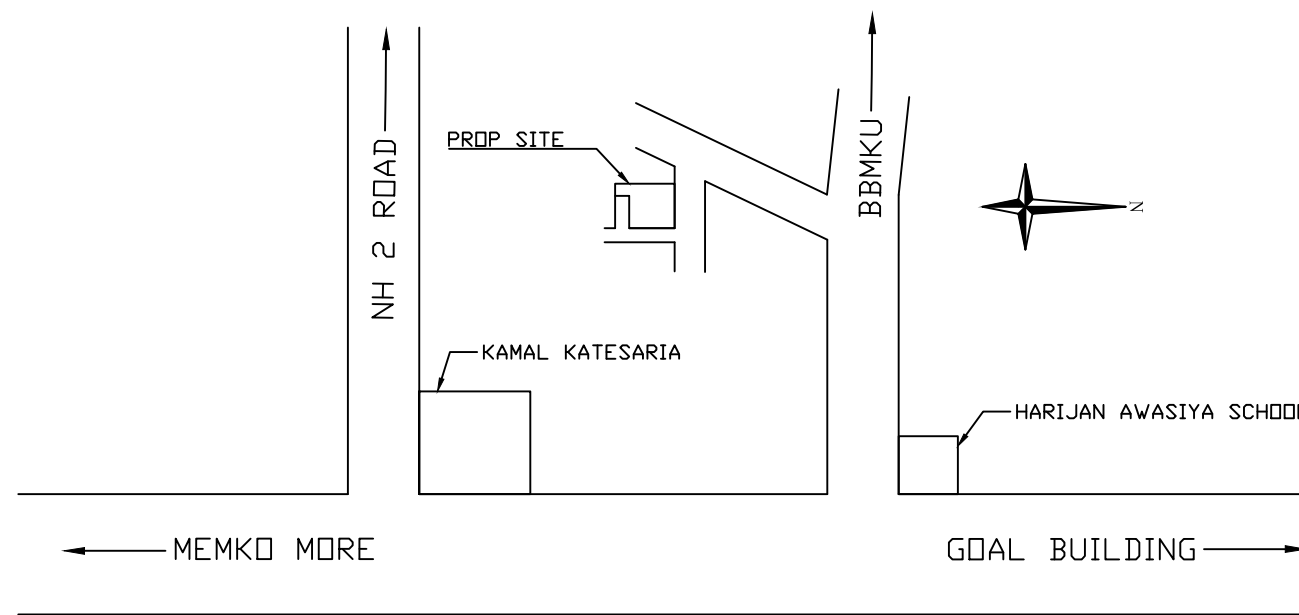

SECTION ON - YY  
SCALE - 1:50

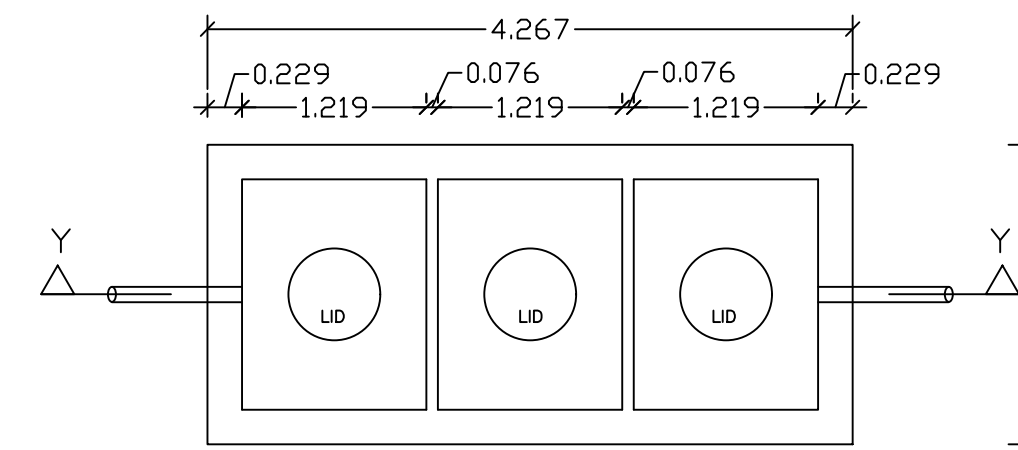

DETAILS OF SEPTIC TANK  
SCALE - 1:50

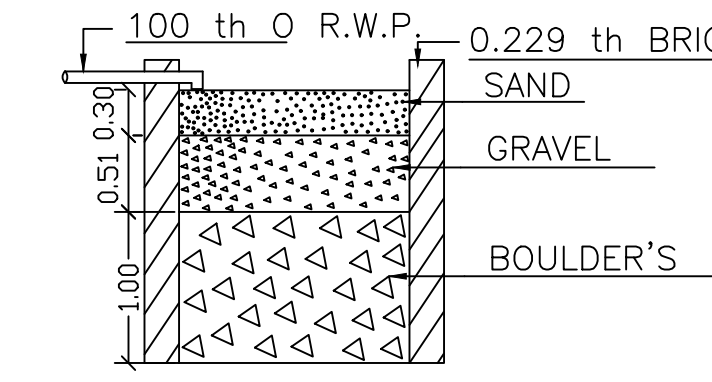

SECTION ON - 'X X'  
SCALE - 1:50

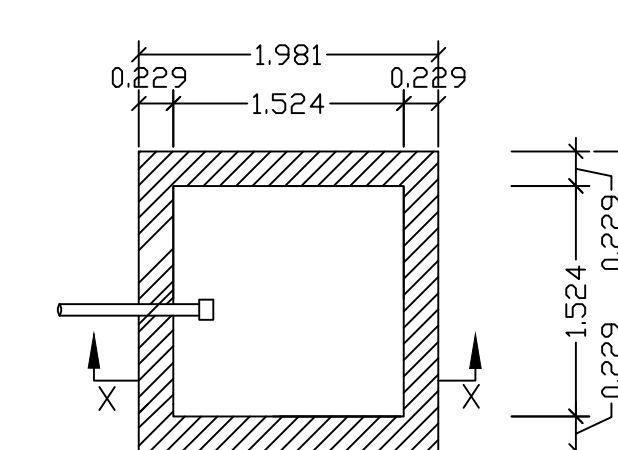

PLAN  
DETAILS OF WATER HARVESTING  
SCALE - 1:50

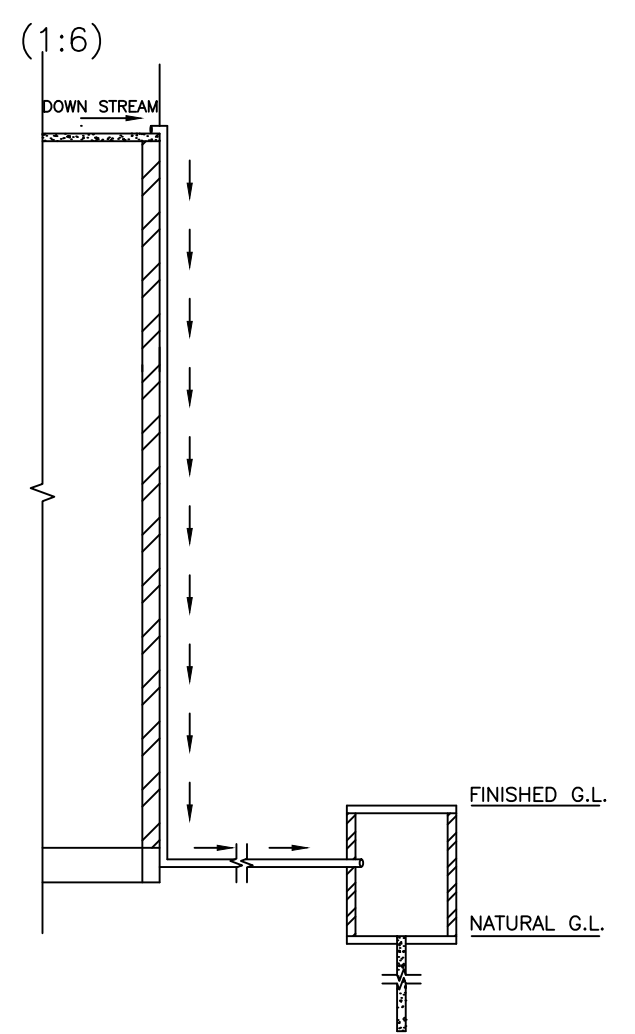

ROOF TOP RAIN WATER  
COLLECTION SYSTEM  
SCALE : 1:96 (1"=8'-0")

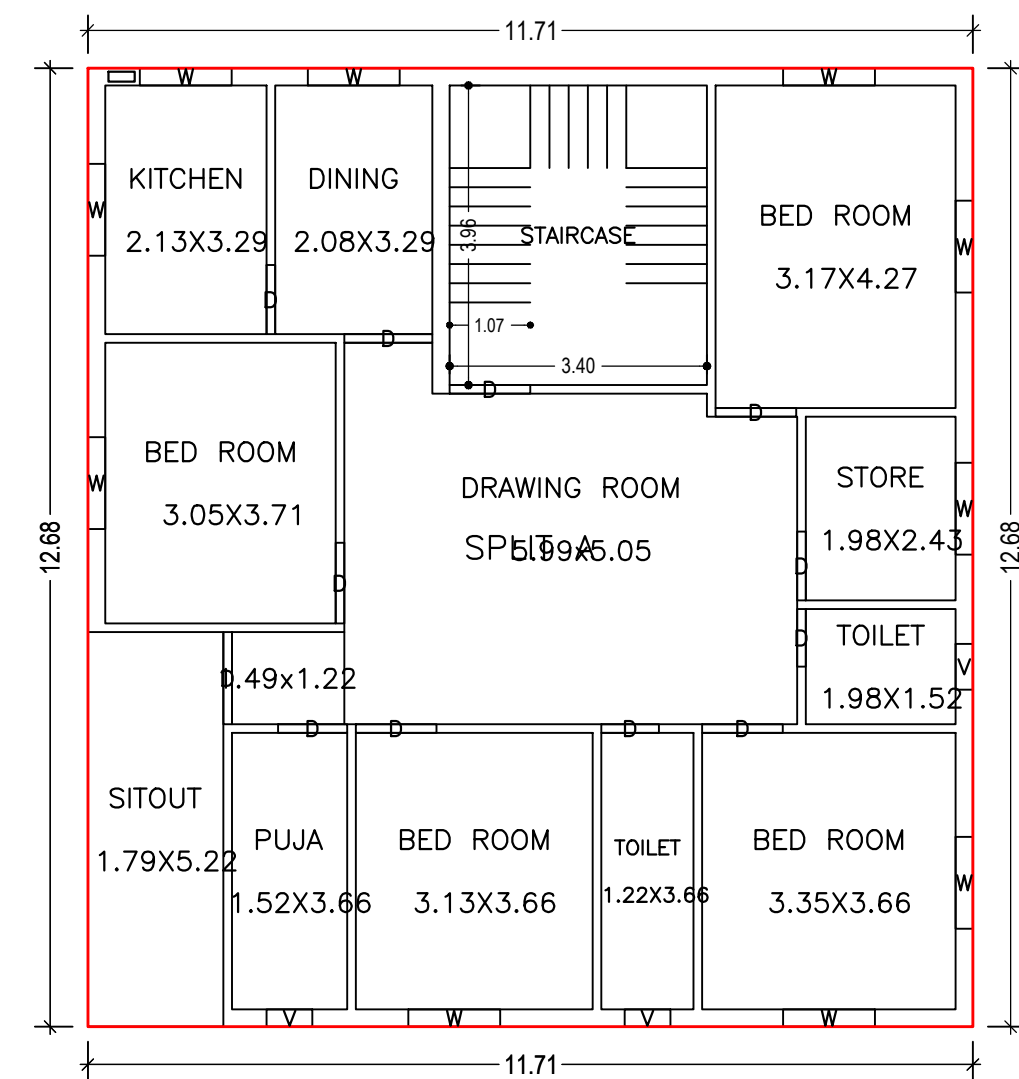

GROUND FLOOR PLAN  
(Proposed)  
(SCALE 1:100)

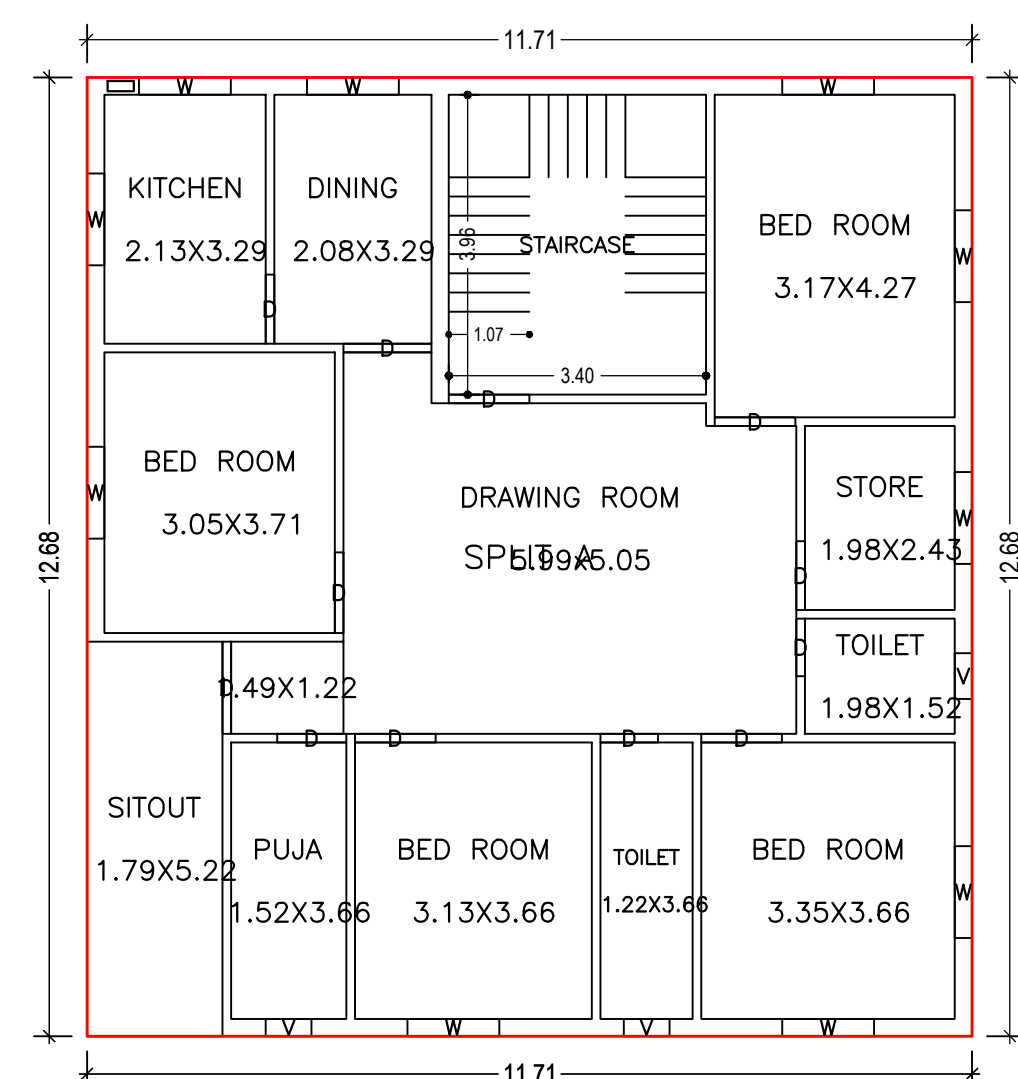

FIRST FLOOR PLAN  
(Proposed)  
(SCALE 1:100)

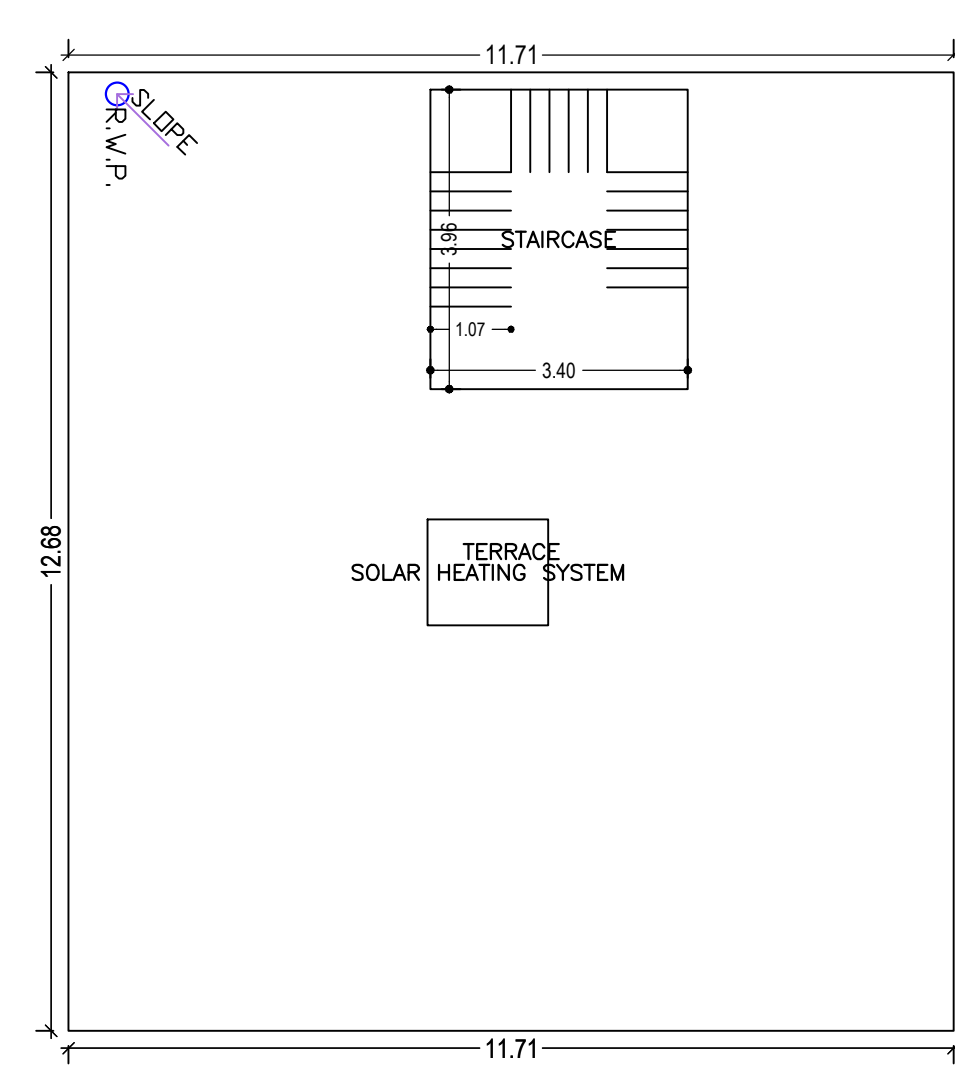

TERRACE FLOOR PLAN  
(SCALE 1:100)

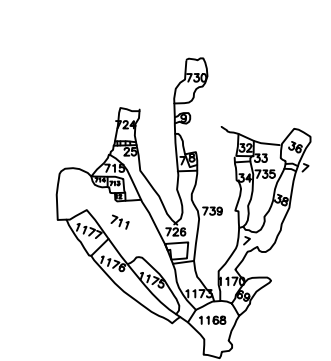

KEY PLAN  
SCALE - NTS

LTP NAME AND SIGNATURE	STRUCTURAL ENG'S NAME AND SIGNATURE	BUILDER NAME AND SIGNATURE	DIGITAL SIGNATURE
SANJEEV KUMAR RAY DMC/ENG/0001/2019			