

| REVISIONS |  | DATE |
|-----------|--|------|
|           |  |      |
|           |  |      |
|           |  |      |
|           |  |      |
|           |  |      |

| NO. | DATE | REVISION |
|-----|------|----------|
| 1   |      |          |
| 2   |      |          |
| 3   |      |          |

### TITLE OF DRAWING

PROPOSED RESIDENTIAL APARTMENT FOR SRI. HALDAR MANDAL, SRI. JAGDISH CHANDRA MANDAL, SRI. RAJESH KR. MANDAL, SRI. BANSIM CHANDRA MANDAL, SRI. KOLAKUSMA, P.O. K.G. ASHRAM, DHANBAD, JHARKHAND. SITE ADDRESS- SUBALA HIGHLAND, NEAR MAA MANSA TEMPLE, KOLAKUSMA, DIST. DHANBAD (JHARKHAND) FOR RESIDENTIAL APARTMENT AT, MOUZA- KOLAKUSMA, OLD KHATA NO- 12, 20, 122, NEW KHATA NO- 234, 486, 388, OLD PLOT NO- 965, 966, 1006, NEW PLOT NO- 1875, 988, 1132, AREA- 22300, SQFT, SITUATED AT THANA NO. 12, DISTRICT- DHANBAD (J H A R K H A N D)

Project Title- SHREE KANHA GARDEN

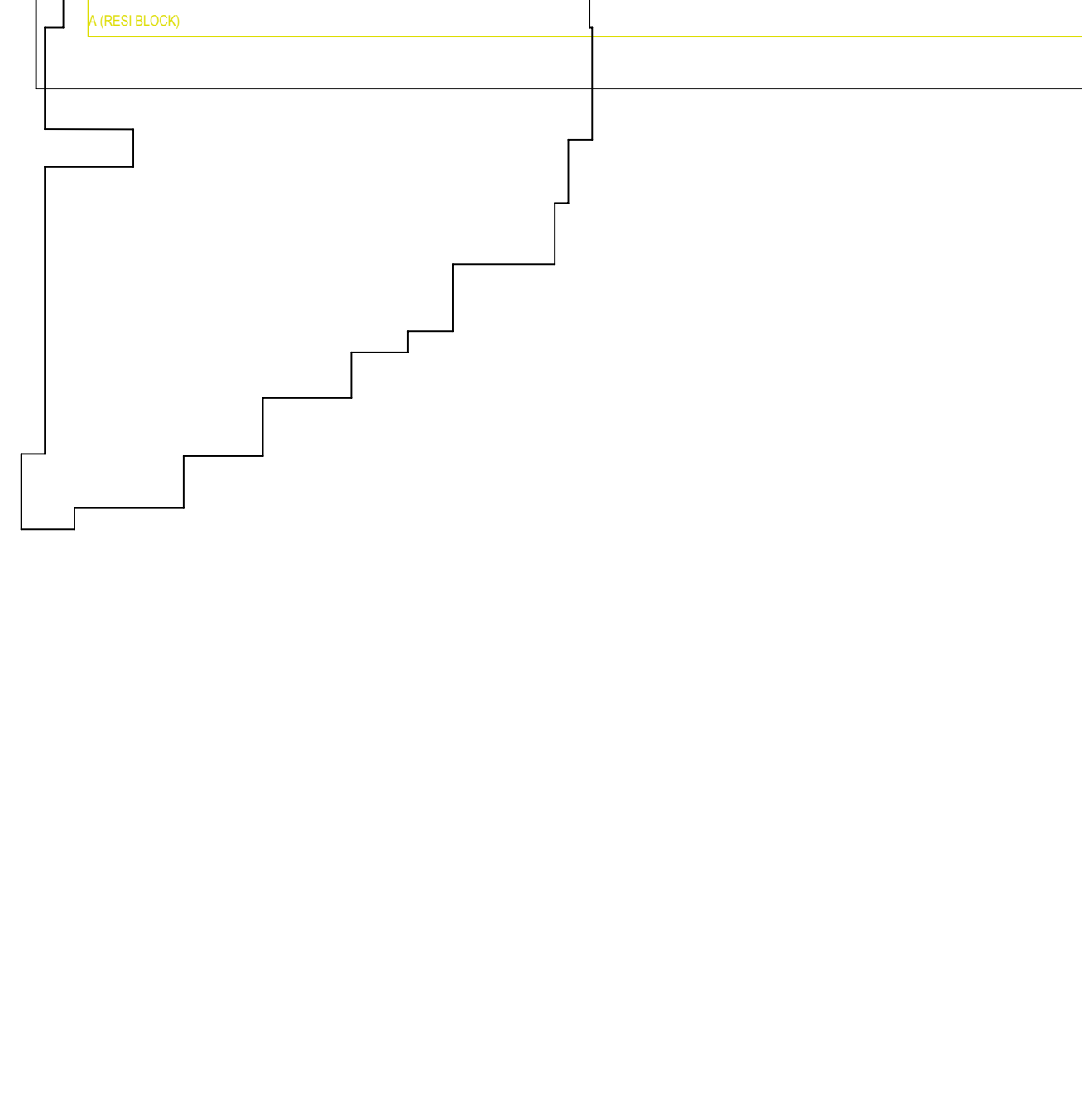
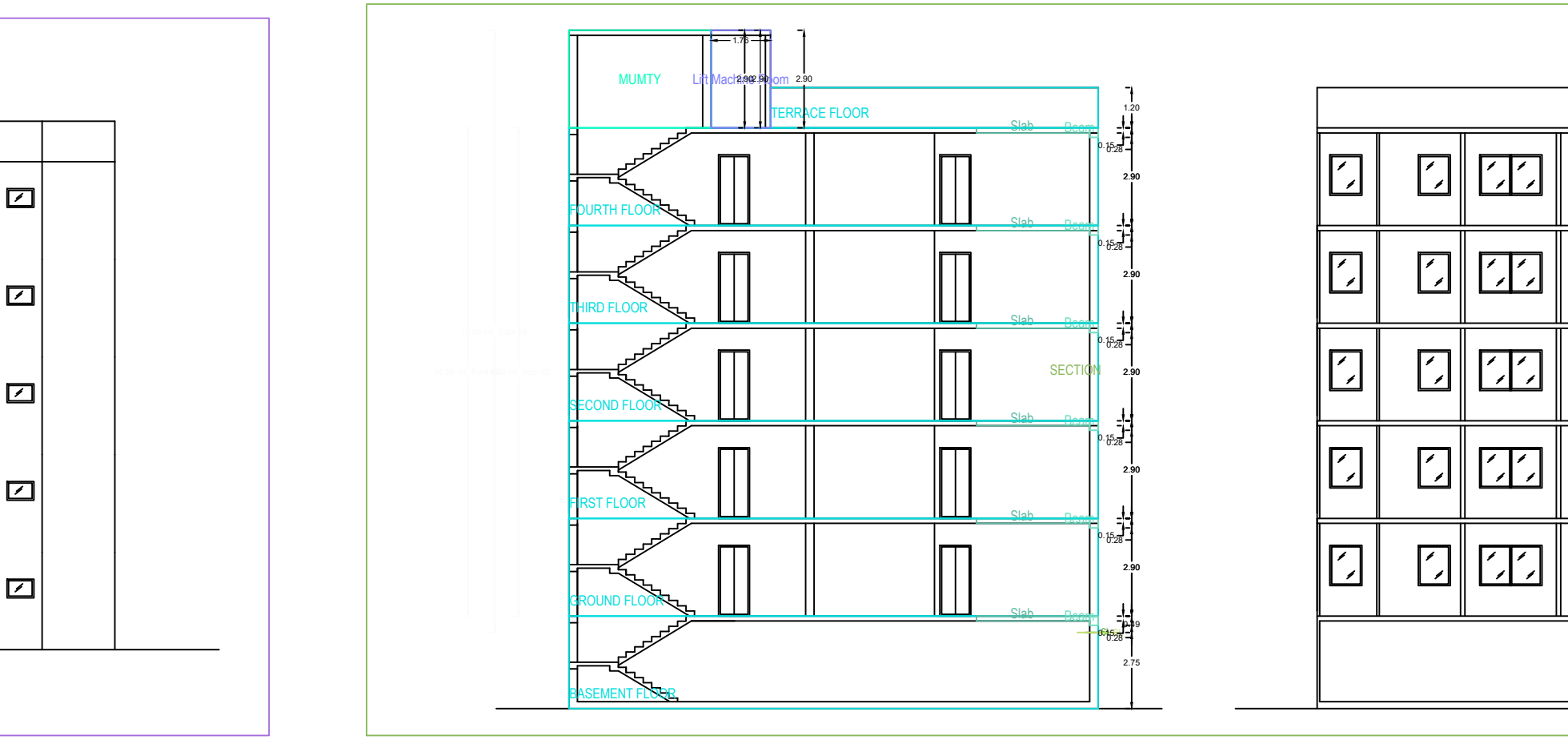
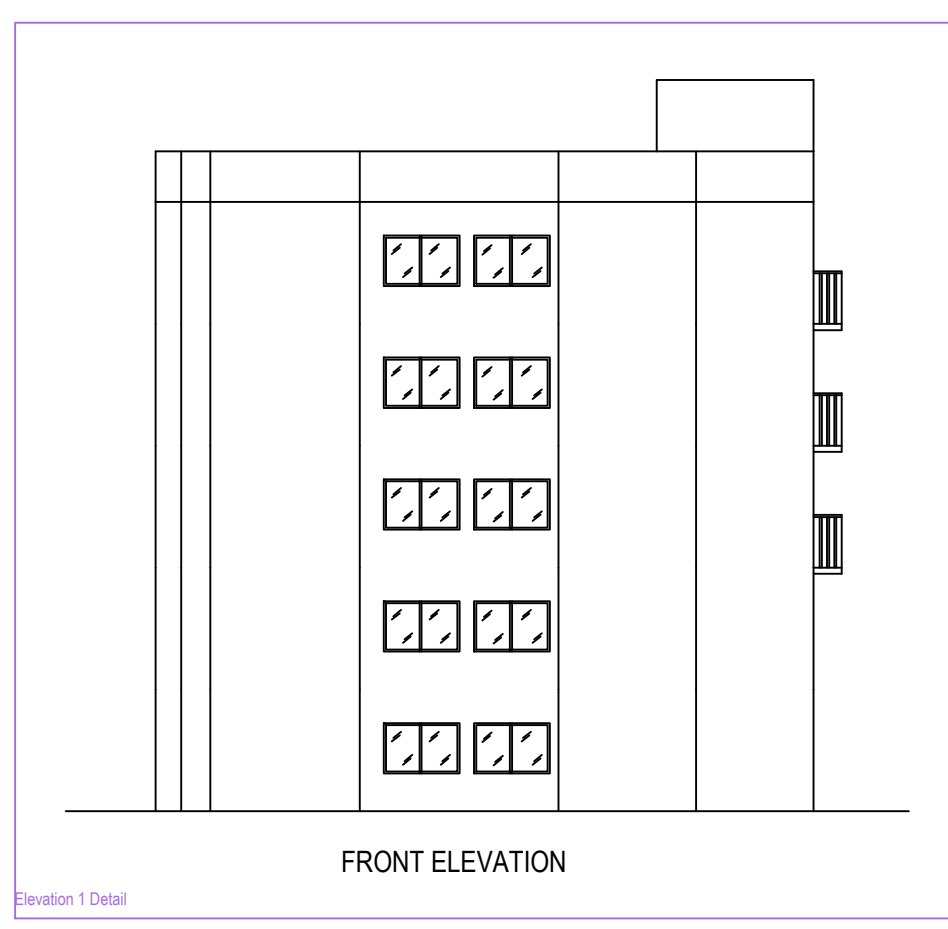
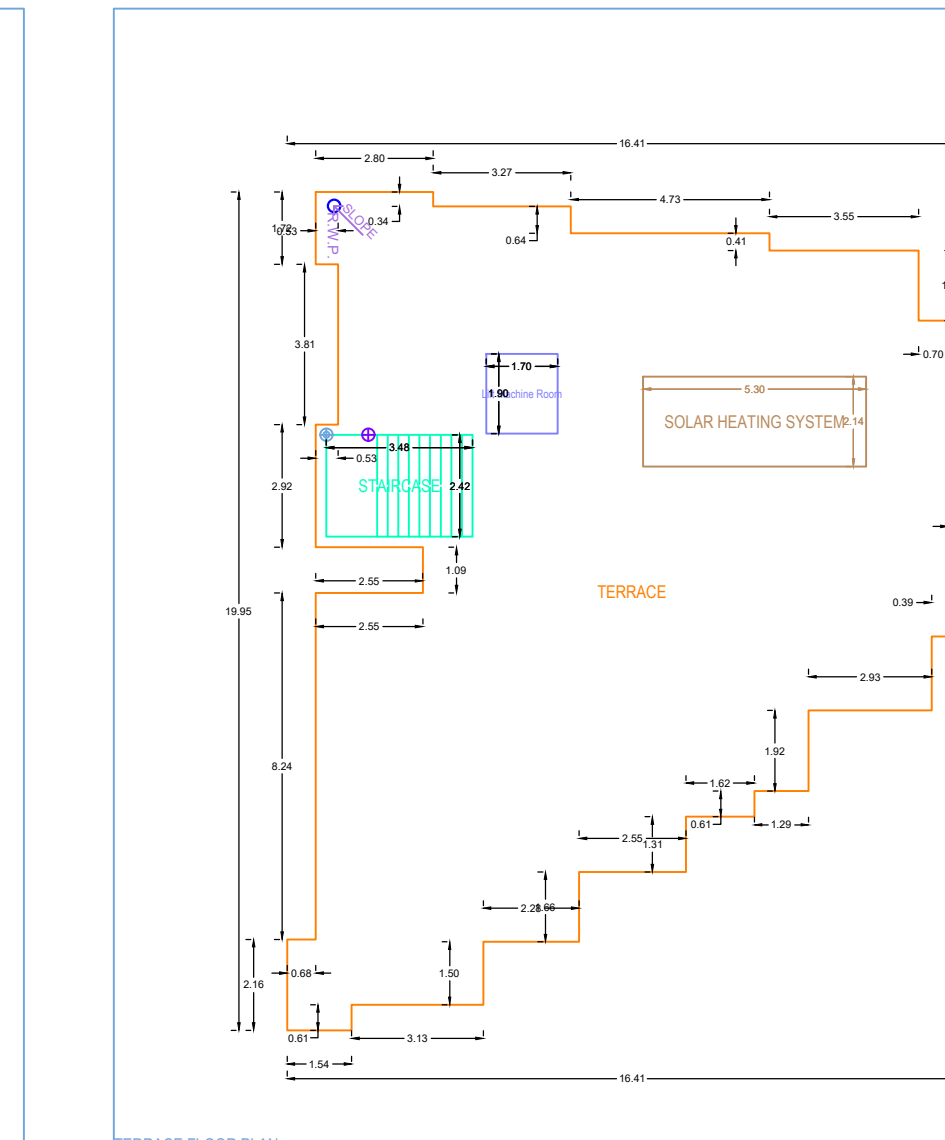
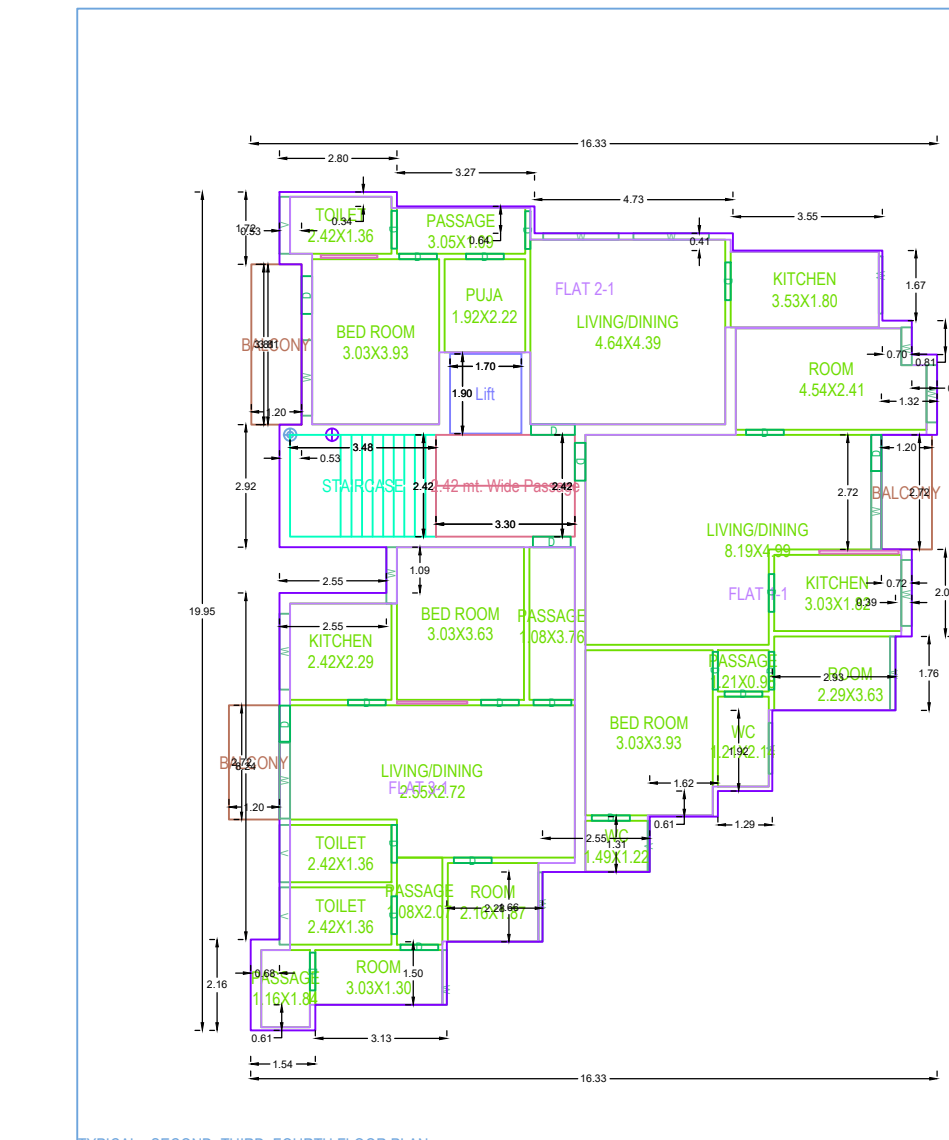
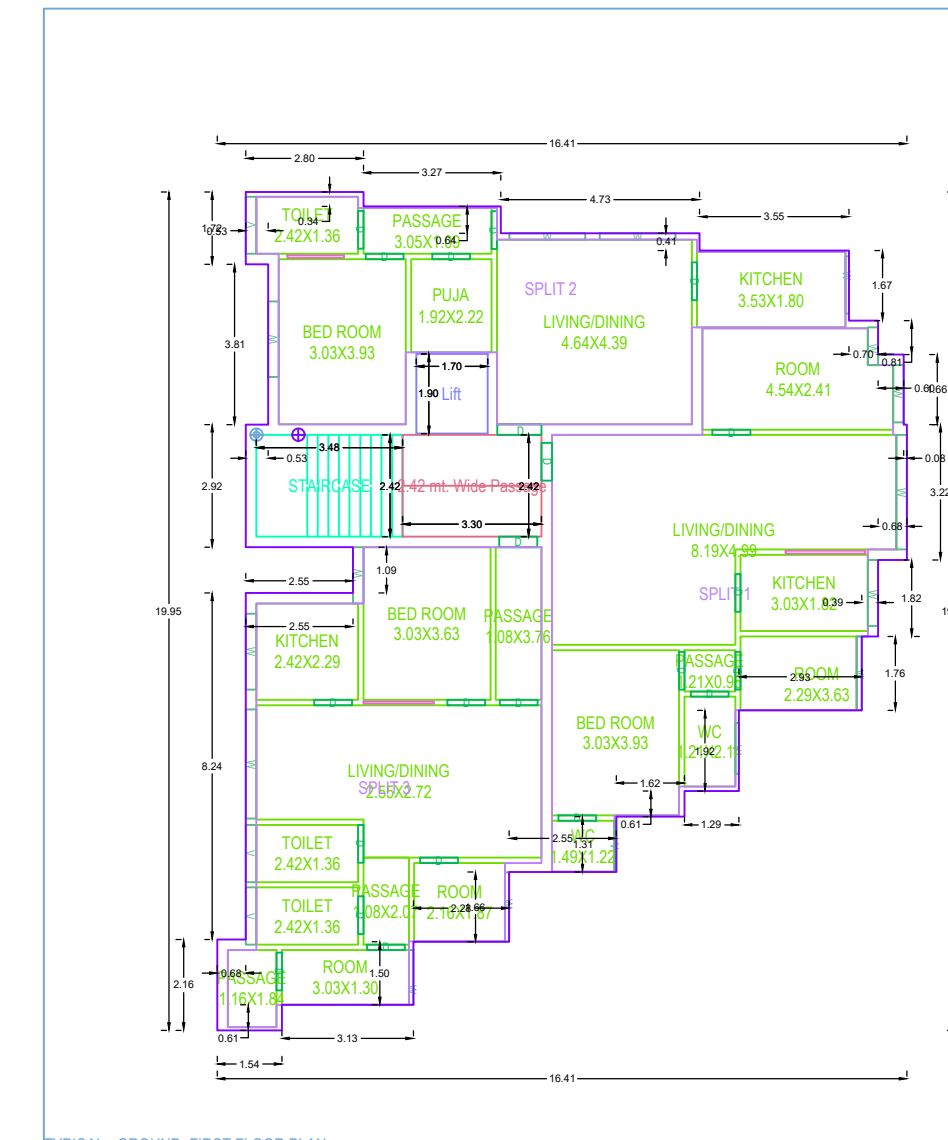
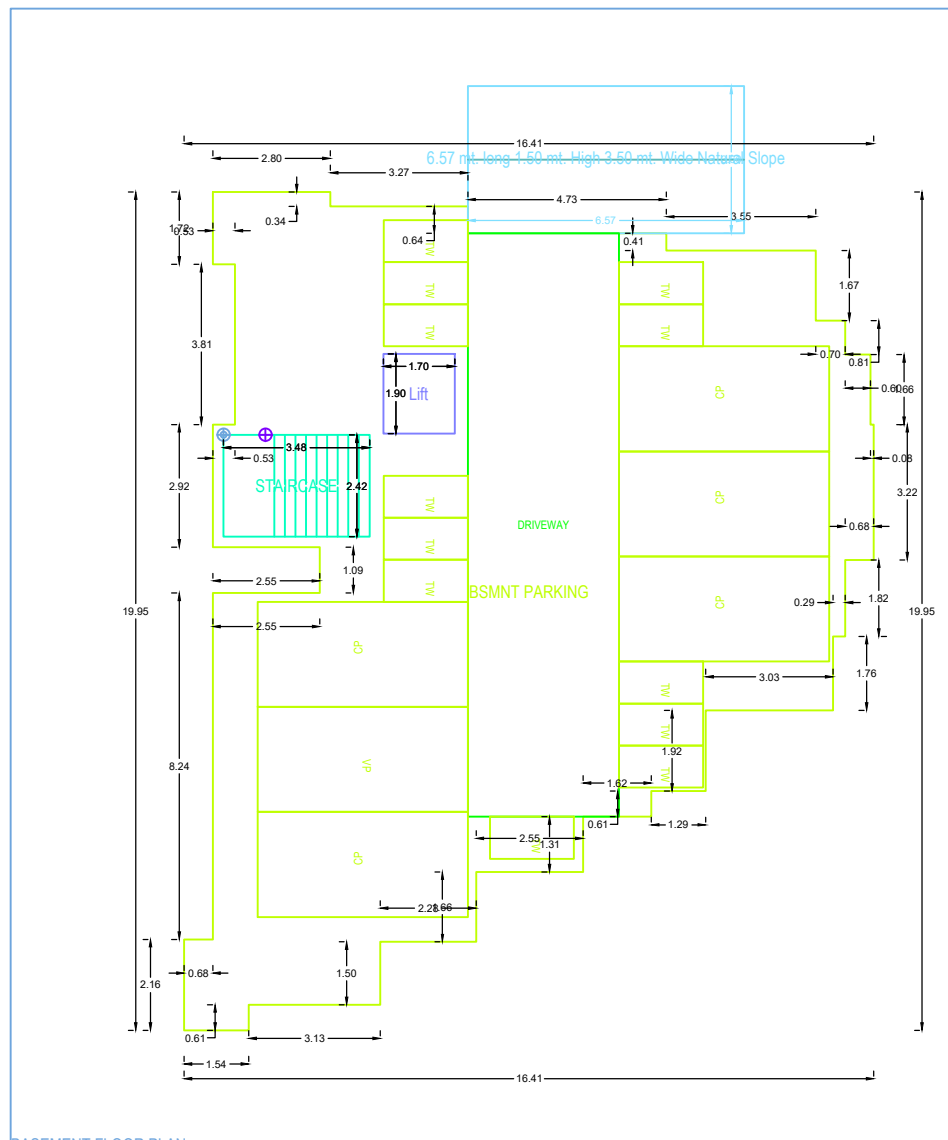
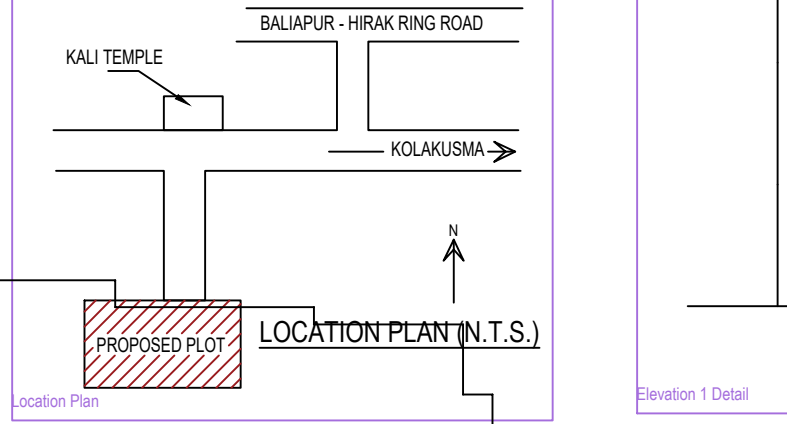
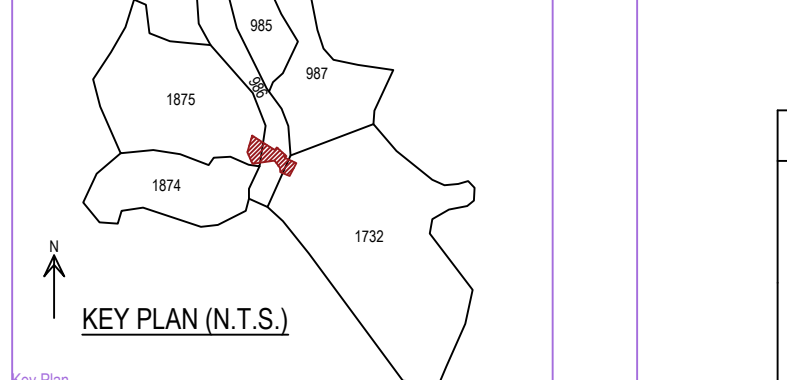
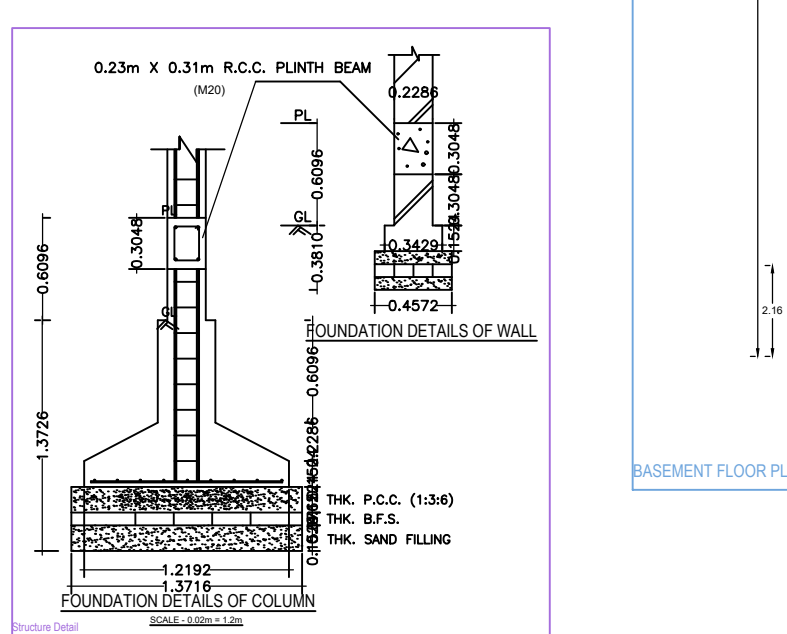
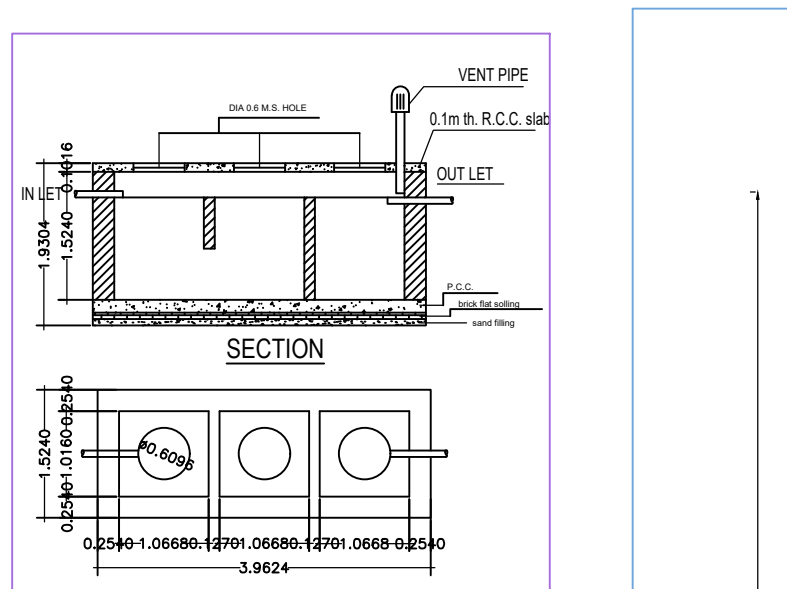
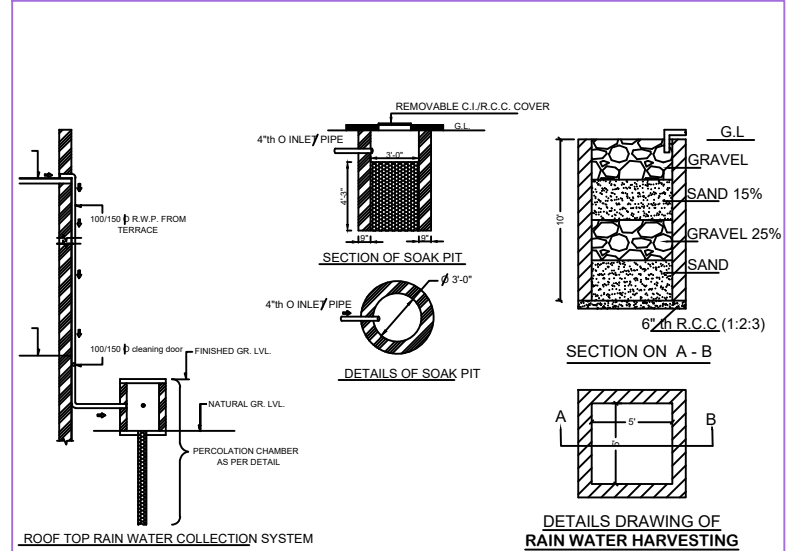

**Building A-RED BLOCK**

| Floor    | Total Area | Net Area | Useful Area | Area per Unit |
|----------|------------|----------|-------------|---------------|
| Basement | 220.00     | 180.00   | 180.00      | 180.00        |
| 1st      | 120.00     | 100.00   | 100.00      | 100.00        |
| 2nd      | 120.00     | 100.00   | 100.00      | 100.00        |
| 3rd      | 120.00     | 100.00   | 100.00      | 100.00        |
| 4th      | 120.00     | 100.00   | 100.00      | 100.00        |

**SCHEDULE OF JOINERY**

| Part | Material | Quantity | Rate | Amount |
|------|----------|----------|------|--------|
|      |          |          |      |        |
|      |          |          |      |        |

**Barry Calculation Table**

| Part | Volume | Rate | Amount |
|------|--------|------|--------|
|      |        |      |        |
|      |        |      |        |

**Area Calculation Table**

| Part | Area | Rate | Amount |
|------|------|------|--------|
|      |      |      |        |
|      |      |      |        |