

Project Title :RUPA KUMARI

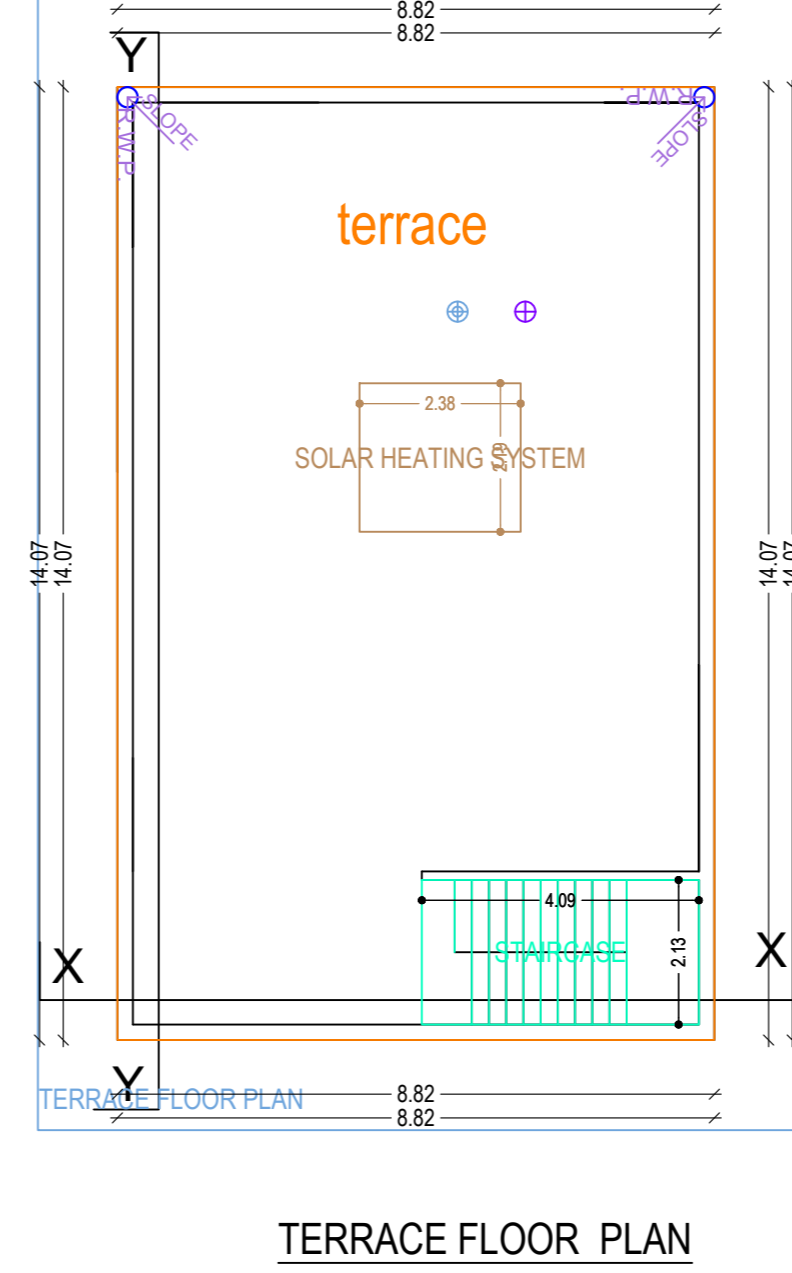
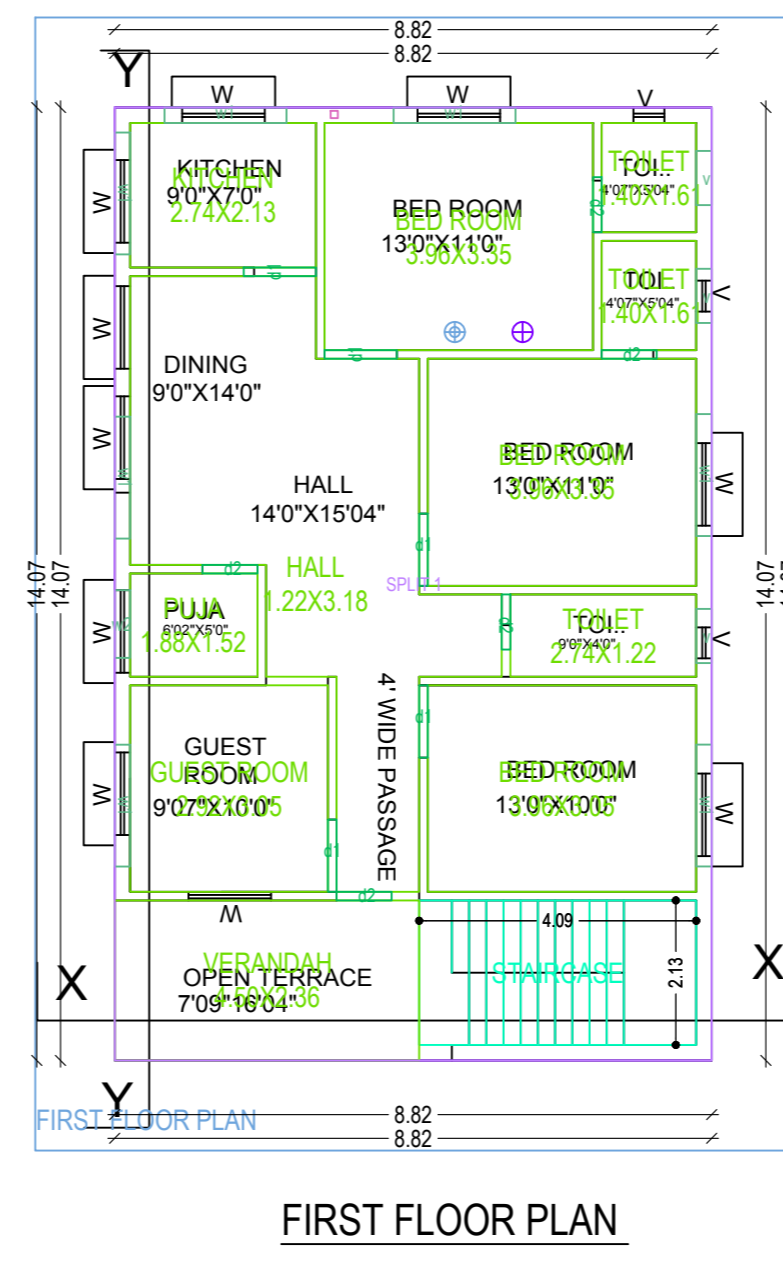
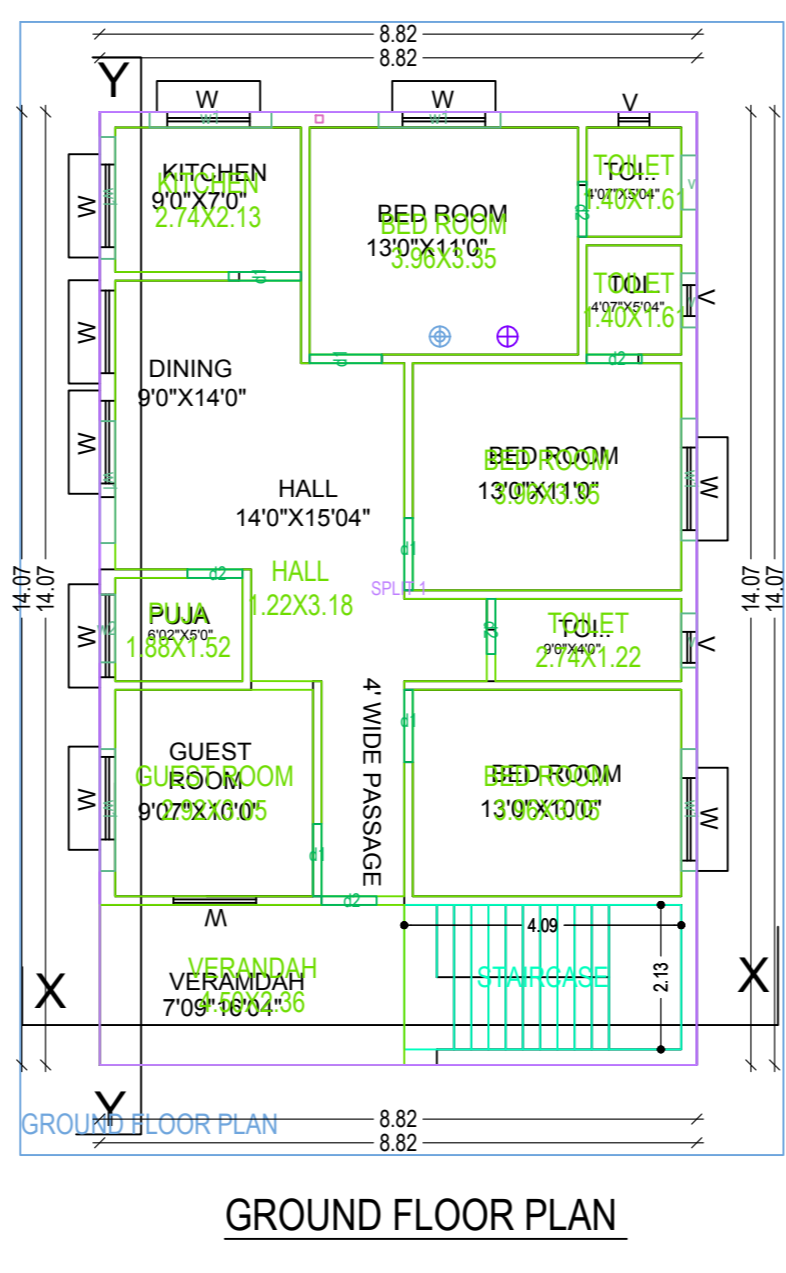
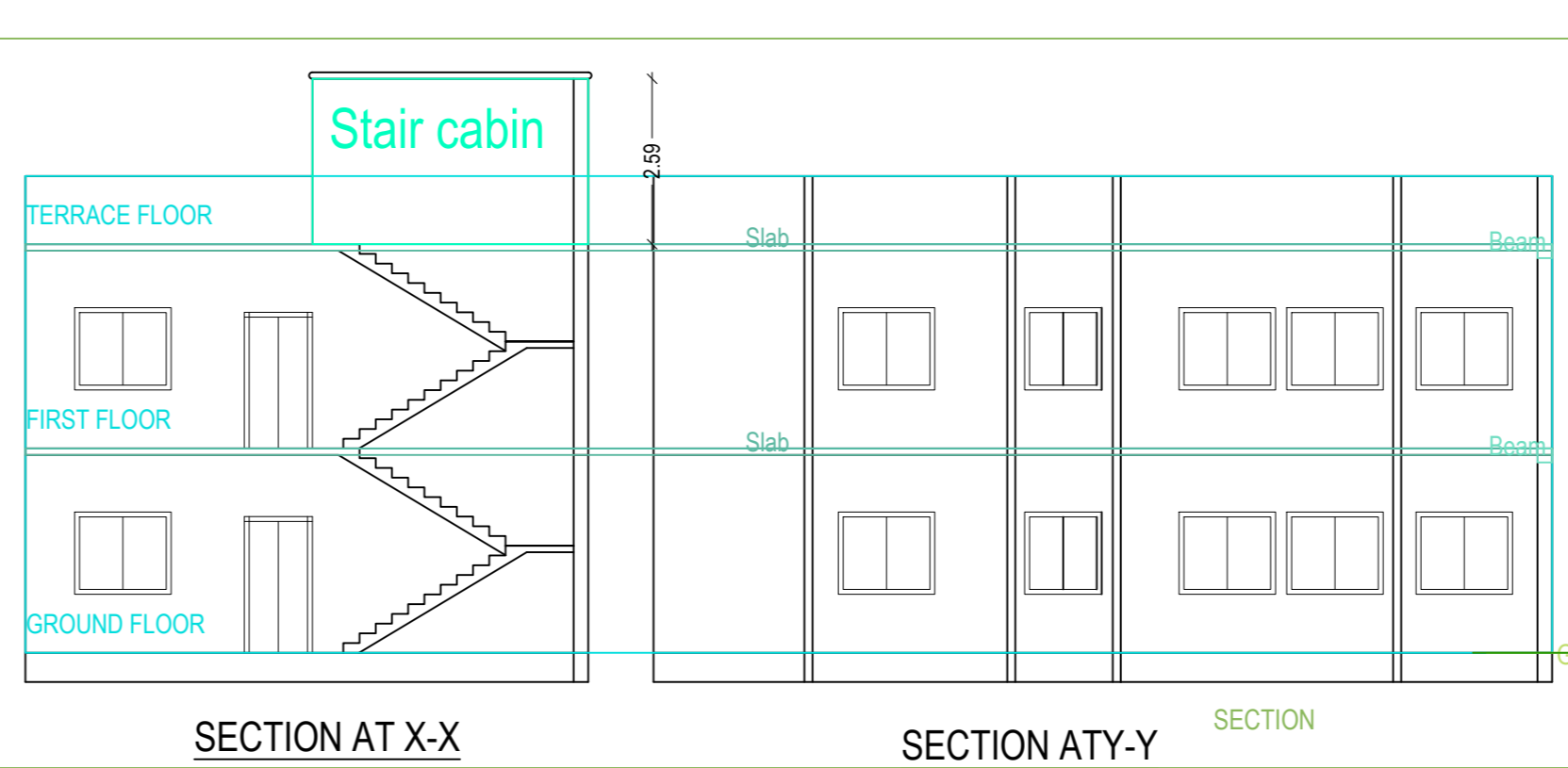
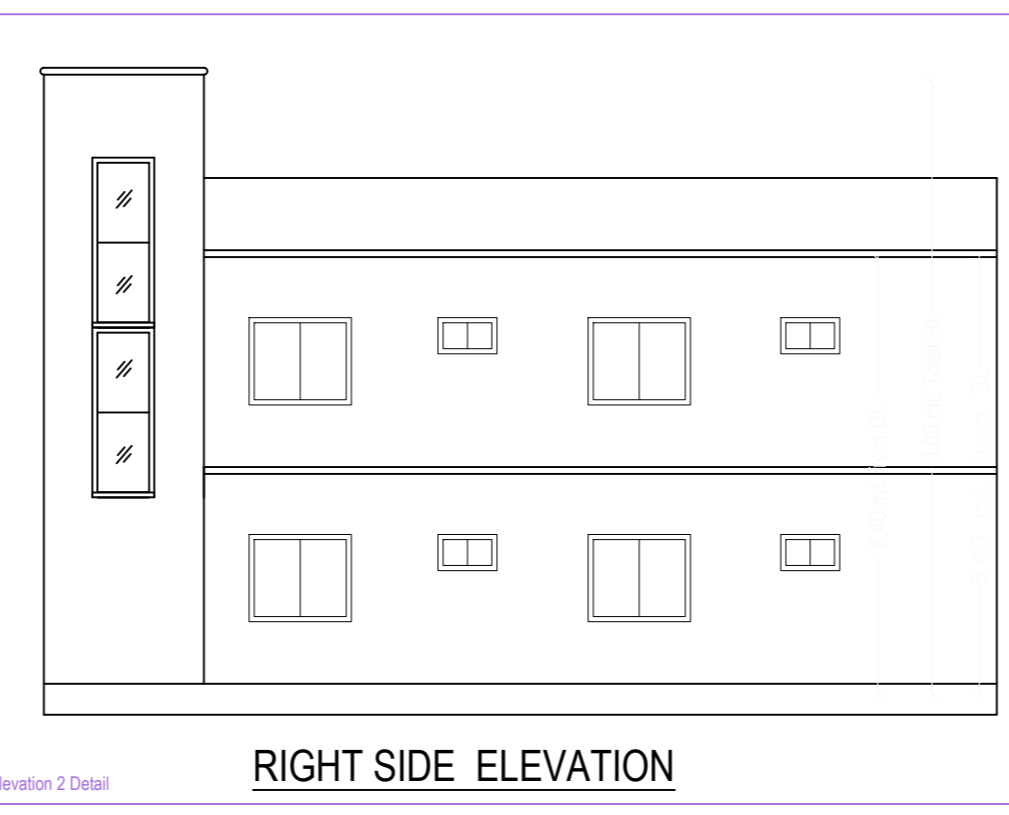
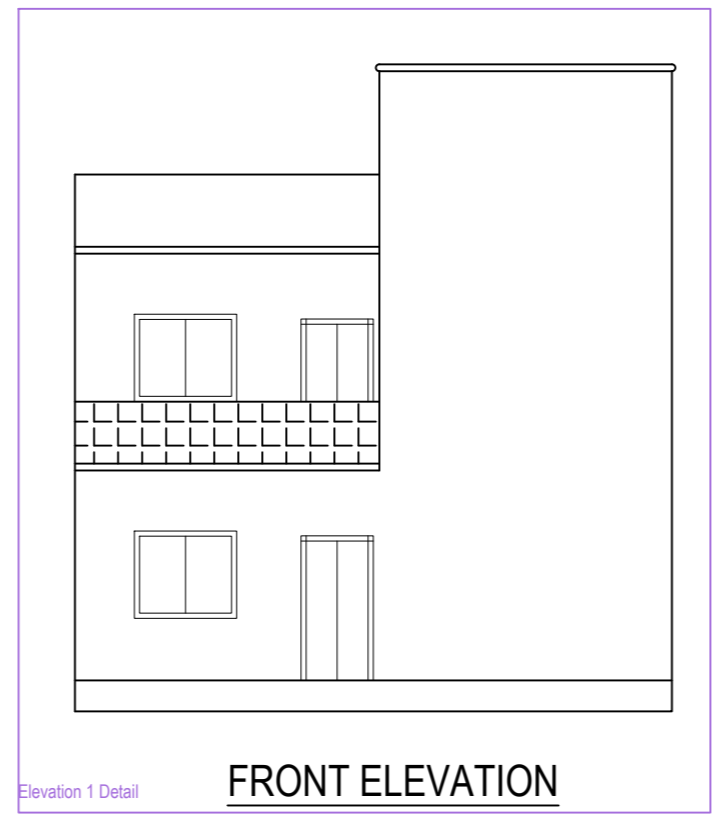
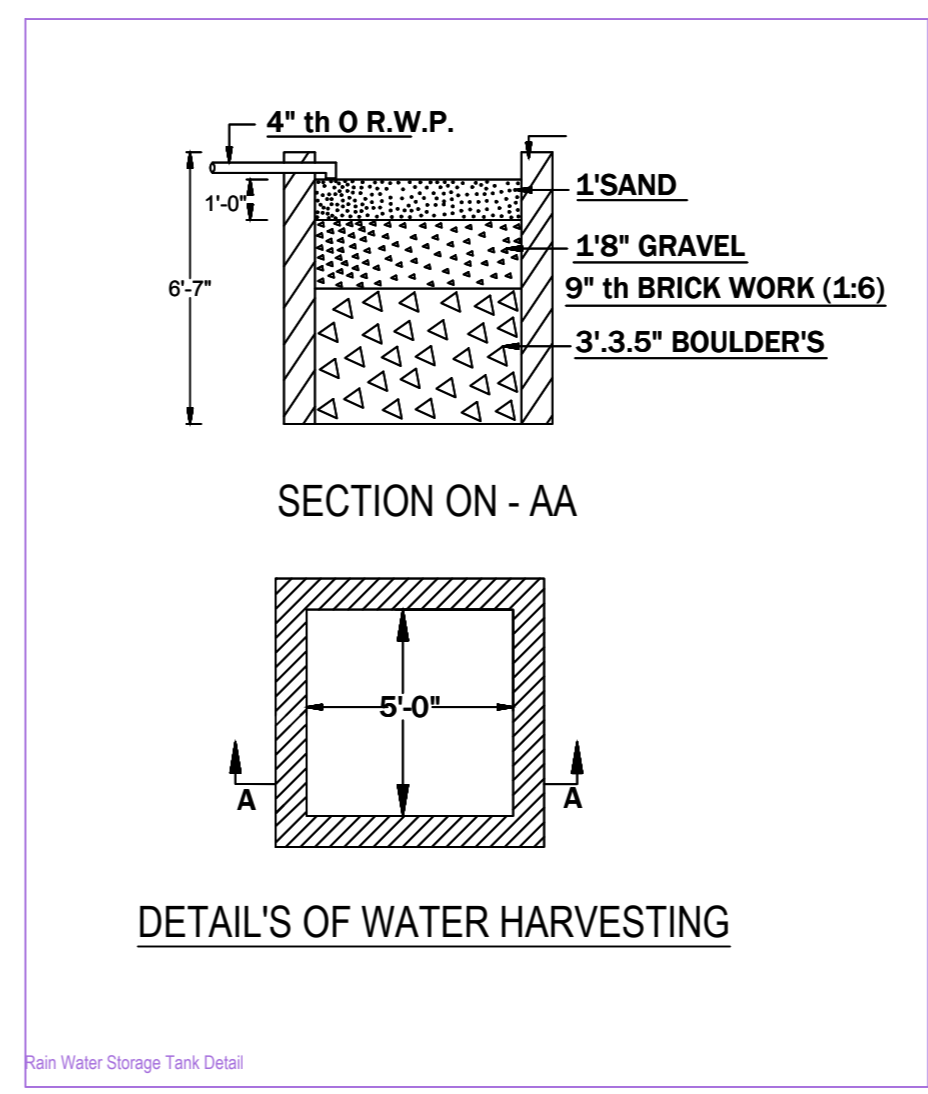
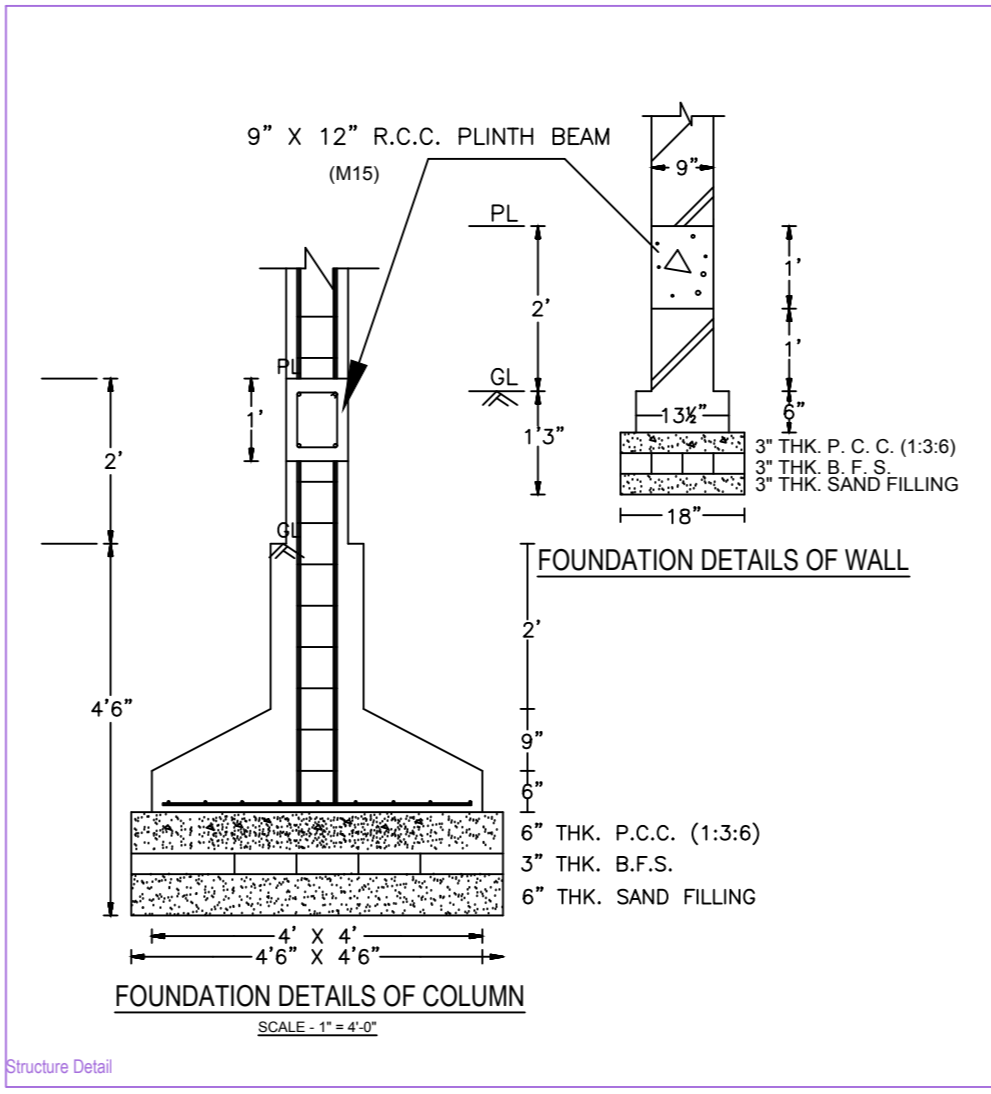
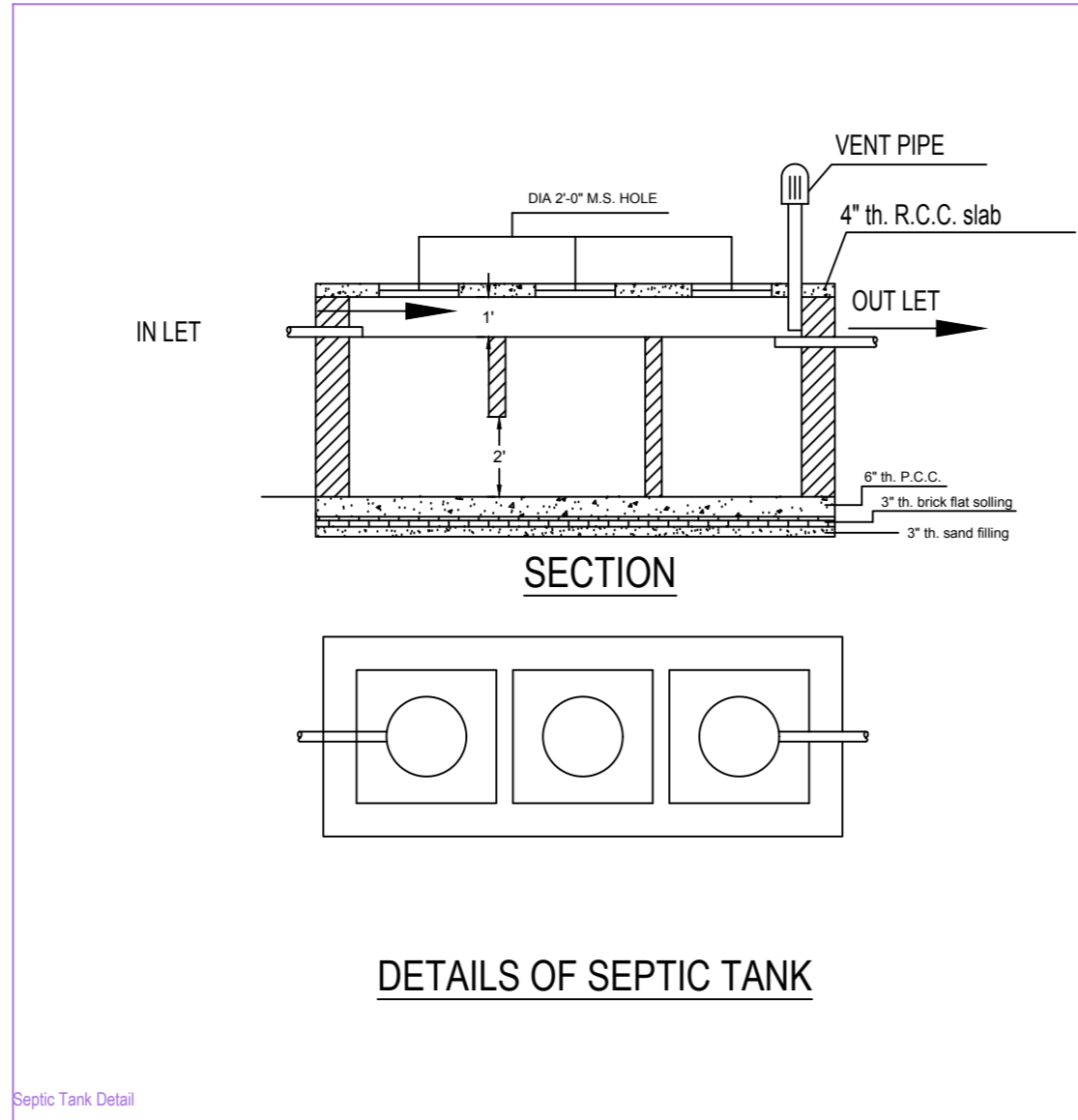
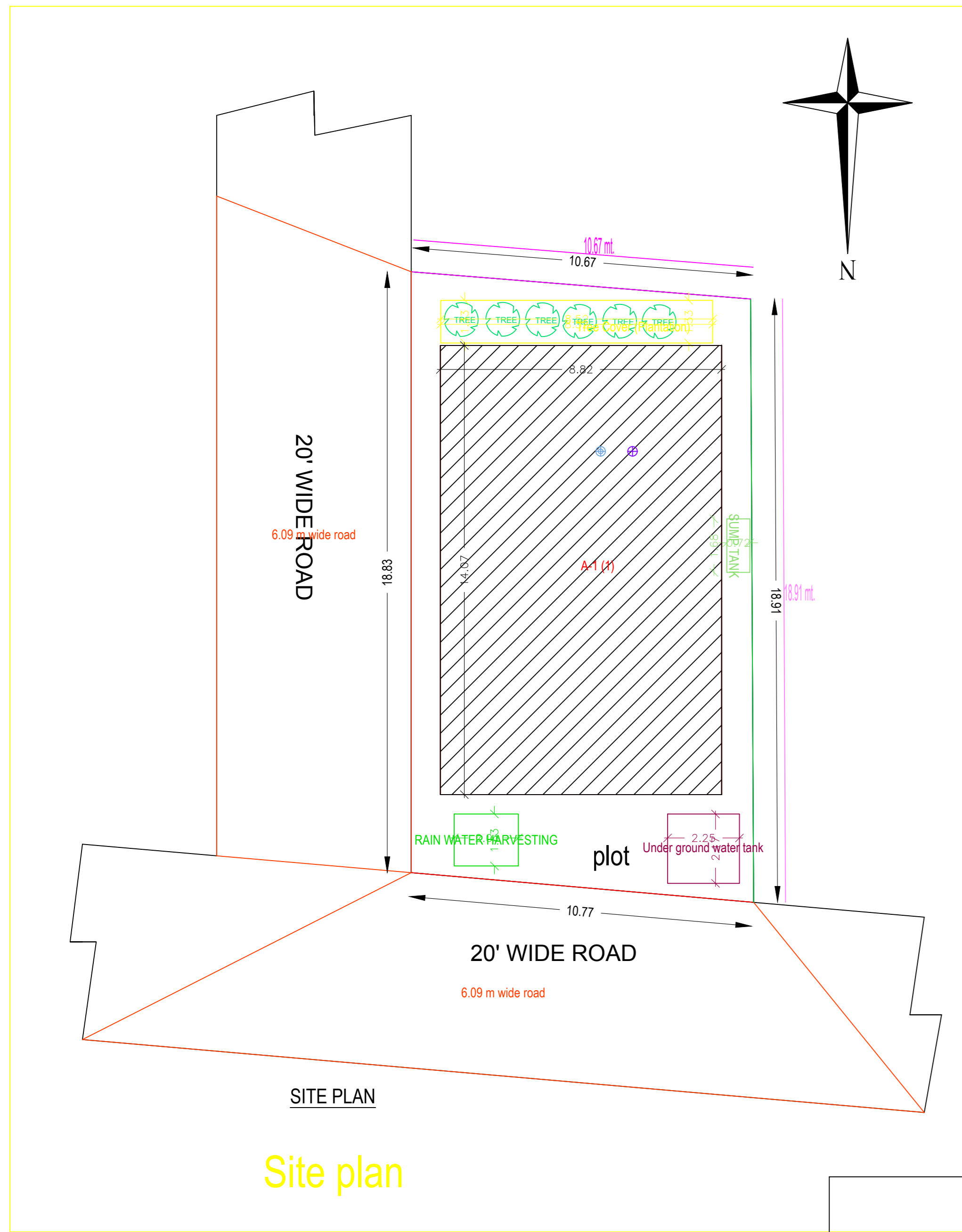

BRIEF SPECIFICATION

FOUNDATION ----- CEMENT CONCRETE (1:3:6)
 BRICK WORK ----- IN FOUNDATION & SUPERSTRUCTURE
 ----- FIRST CLASS BRICK WORK IN CEMENT MORTAR (1:5)
 D.P.C ----- 1" P.S OVER 3" P.C.C
 FLOOR ----- 4" THK. R.C.C ROOF (1:1.5:3)
 ROOF ----- 6" THK. R.C.C LINTEL (1:1.5:3)
 LITEL -----
 STAIR ----- RISE = 6" , TREAD = 10"
 SLAB, BEAM, COLUMN ----- ALL R.C.C WORK (1:1.5:3)
 WOOD WORK ----- ALL DOOR & WINDOW FRAMES OF S.A. WOOD.
 PLASTERING WORK ----- 12mm CEMENT PLASTER (1:6) BOTH SIDE.

SCHEDULE

D1 - 3'-6" X 7'-0"	W - 3'-0" X 4'-0"
D2 - 3'-0" X 7'-0"	W1 - 4'-0" X 4'-0"
D3 - 2'-6" X 7'-0"	W2 - 5'-0" X 4'-0"
CG - 4'-0" X 7'-0"	V - 3'-0" X 2'-0"

DETAILS OF AREA

1) TOTAL AREA OF THE LAND	201.58 sqm
2) GROUND FLOOR AREA	124.07 sqm
3) FIRST FLOOR AREA	124.07 sqm
4) COVERED AREA	248.14 sqm
5) % OF PLINTH AREA	61.54%
6) F.A.R	0.81

TITLE OF DRAWING

RESIDENTIAL BUILDING PLAN OF SMT RUPA KUMARI W/ SRI DEEPAK KUMAR CHOUHARY (INTENDING PURCHASER) UNDER MOUZA -KOLAKUSHMA , MOUZA NO.-12 , PLOT NO. : 1193 KHATA NO. :14 , P.S - DHANHAD , IN THE DISTT. OF DHANBAD (JH).

SIG. OF OWNER

SIG. OF ENGINEER

Floor Name	Total Built Up Area (Sq.mt)	Proposed FAR Area (Sq.mt)	Total FAR Area (Sq.mt)	Tent (No.)
Ground Floor	124.07	124.07	124.07	01
First Floor	124.07	124.07	124.07	00
Terrace Floor	0.00	0.00	0.00	00
Total	248.14	248.14	248.14	01
Total Number of Same Buildings	1			
Total	248.14	248.14	248.14	01

SCHEDULE OF JOINERY:

BUILDING NAME	NAME	LENGTH	HEIGHT	NOS
A(1)	D2	0.81	2.10	10
A(1)	D1	1.07	2.10	10
Total				20

SCHEDULE OF JOINERY:

BUILDING NAME	NAME	LENGTH	HEIGHT	NOS
A(1)	V	0.80	1.00	06
A(1)	W2	1.00	1.20	02
A(1)	W1	1.80	1.20	14
Total				22

UnitBUA Table for Building A (1)

FLOOR	Name	UnitBUA Type	UnitBUA Area	Carpet Area	No. of Rooms	No. of Tenement
GROUND FLOOR PLAN	SPLIT 1	FLAT	248.14	248.12	11	1
Total			248.14	248.12	22	1

AREA DETAILS:	AREA OF PLOT (Minimum)	(A)	SQ.MT
Net Plot Area (Gross Plot Area - Deduction from Gross Plot Area)			201.58
Total Area (Gross Plot Area)			201.58
Deductions for Balance Plot Area (from Gross Plot Area)			11.38
Balance Plot Area (Net Plot Area - Recreational/Amenity space)	(A-Deductions)		190.21
Plot Area for Coverage (Net Plot Area)	(A-Deductions)		201.58
Plot Area for FSI (Net Plot Area + Road/Waterway Area)	(A-Deductions)		201.58
COVERAGE CHECK			
Proposed Coverage Area (E:55%)			124.07
Total Coverage Area (E:55%)			124.07
FAR CHECK			
Proposed Area of FAR			248.14
Total Area of FAR			248.14
BUILT UP AREA CHECK			
Total Proposed Built-Up Area			248.14
ARCHT/ENGT SUPERVISOR (Regd)		OWNER	
DEVELOPMENT AUTHORITY		LOCAL BODY	

COLOR INDEX

PILOT BOUNDARY	Green
ABUTTING ROAD	Red
PROPOSED WORK (COVERAGE AREA)	Blue
EXISTING (To be retained)	Yellow
EXISTING (To be demolished)	Black

Color Index

MARGIN INDEX:

Building / Wing Name	Road Name	Front Margin	Rear Margin	Side1 Margin	Side2 Margin
A(1)	6.00 m wide road	2.52	1.52	0.81	0.81

FAR & Tenement Details (Table 4c-1)

Building	No. of Same Bldg	Total Built Up Area (Sq.Mt)	Proposed FAR Area (Sq.Mt)	Total FAR Area (Sq.Mt)	Tent (No.)
A(1)	1	248.14	248.14	248.14	01
Grand Total:		248.14	248.14	248.14	01