

SITE PLAN

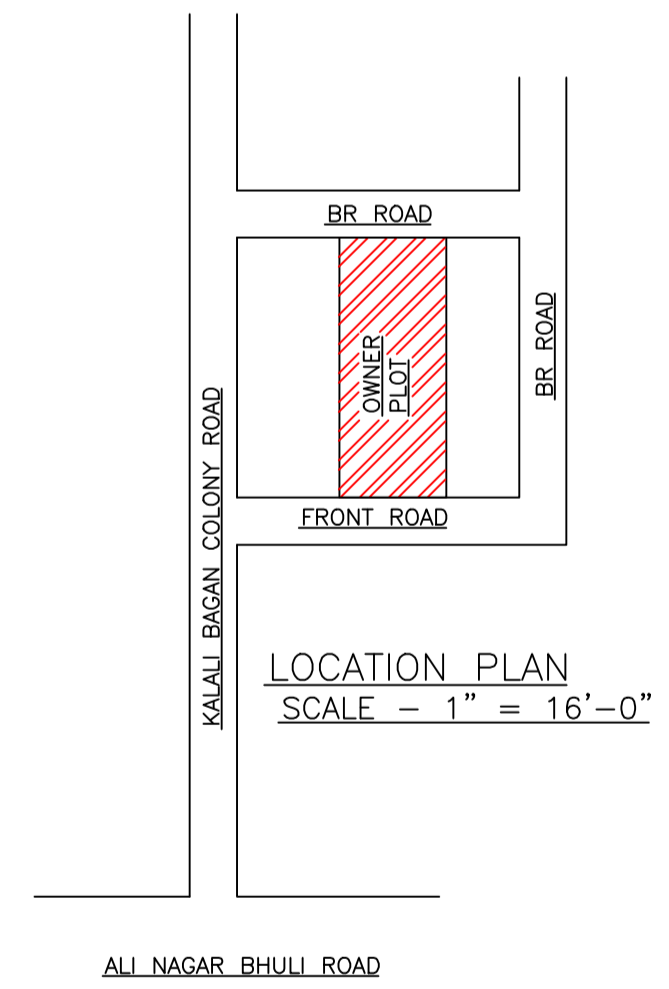

SCHEDULE OF DOOR:

BUILDING NAME	NAME	LENGTH	HEIGHT	NOS
A (BUILDING)	D	1.07	2.10	30

SCHEDULE OF WINDOW/VENTILATION:

BUILDING NAME	NAME	LENGTH	HEIGHT	NOS
A (BUILDING)	W	1.06	1.20	06
A (BUILDING)	W	1.80	1.20	24

Building :A (BUILDING)

Floor Name	Total Built Up Area (Sq.mt.)	Proposed FAR Area (Sq.mt.)	Total FAR Area (Sq.mt.)	Total Consumed Additional FAR Area (Sq.mt.)	Tnmt (No.)
Ground Floor	90.46	90.46	90.46	90.46	01
First Floor	90.46	90.46	90.46	90.46	00
Second Floor	90.46	90.46	90.46	90.46	00
Terrace Floor	0.00	0.00	0.00	0.00	00
Total :	271.38	271.38	271.38	271.38	01
Total Number of Same Buildings :	1				
Total :	271.38	271.38	271.38	271.38	01

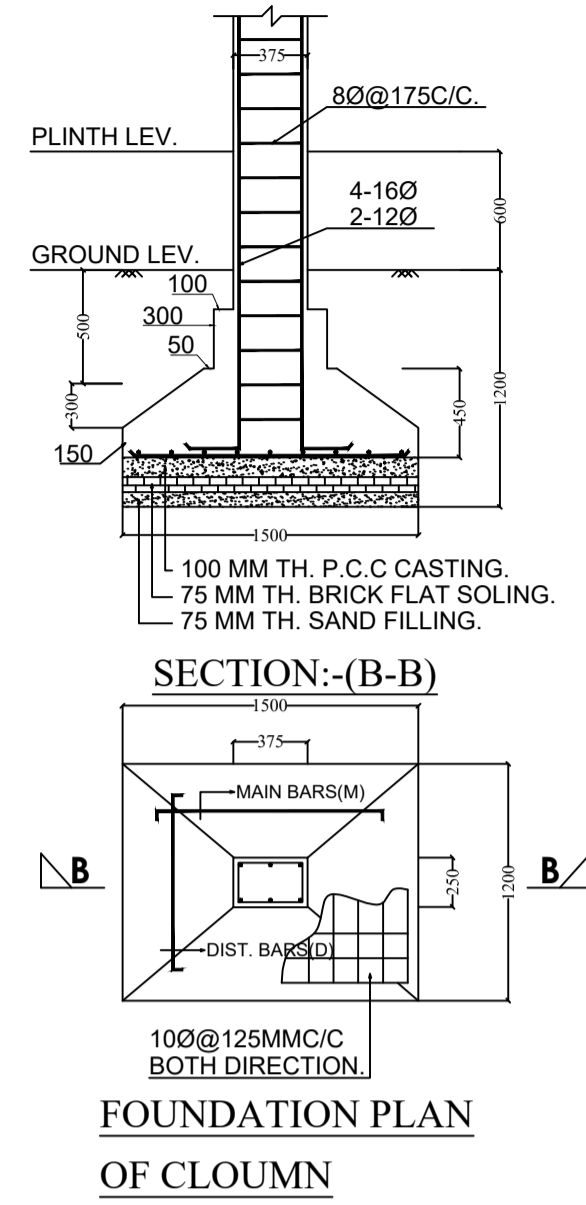

FOUNDATION PLAN OF COLUMN

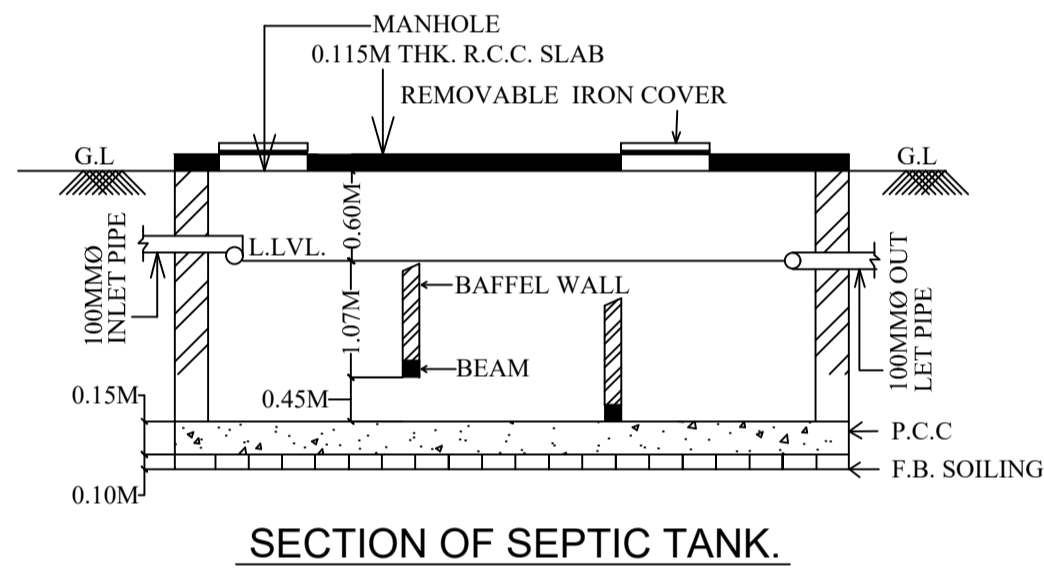

SECTION OF SEPTIC TANK.

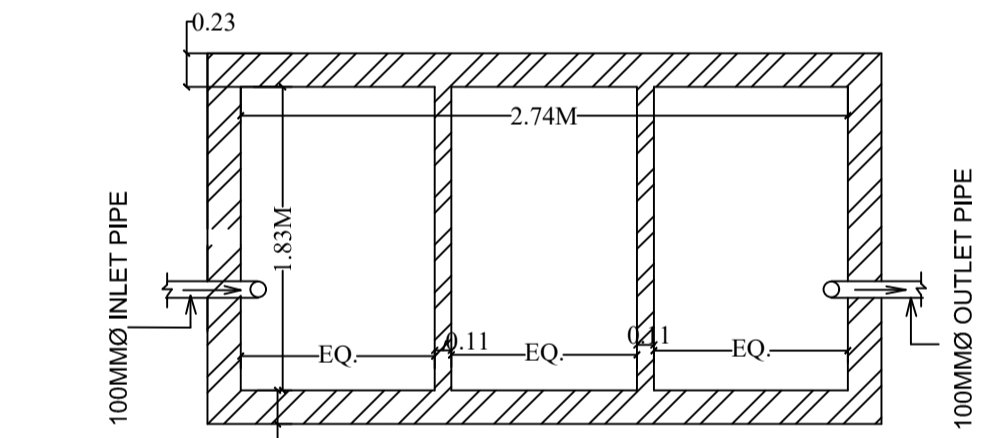

PLAN OF SEPTIC TANK.

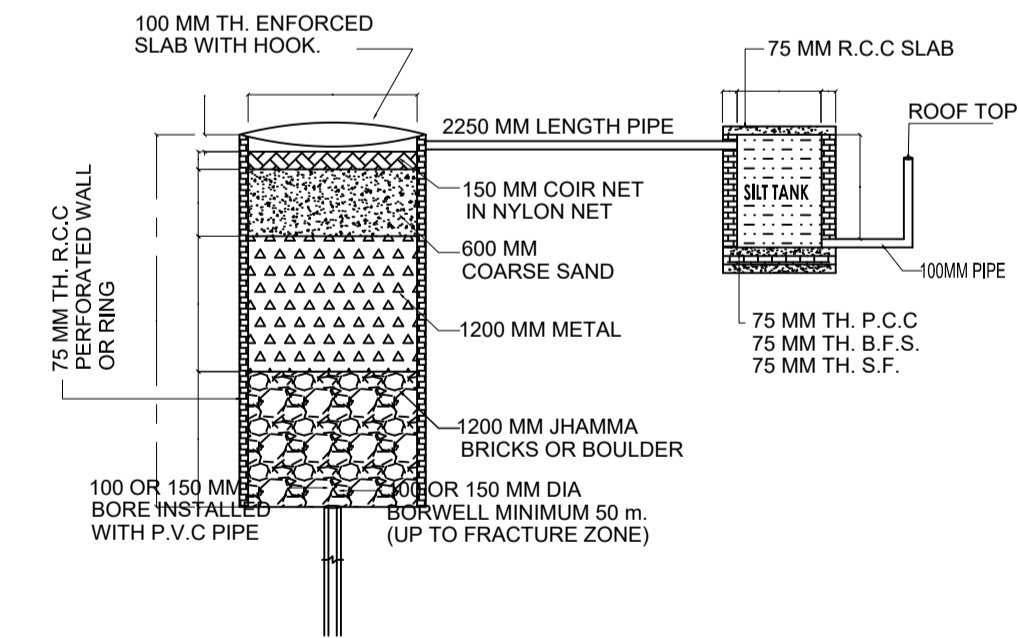

DETAIL OF GROUND WATER RECHARGING PIT WITH SILT TANK

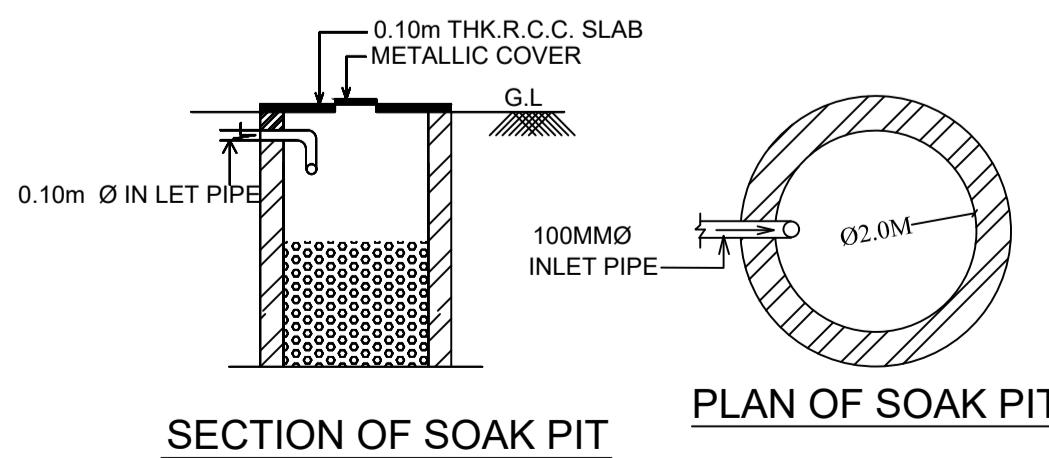

SECTION OF SOAK PIT PLAN OF SOAK PIT

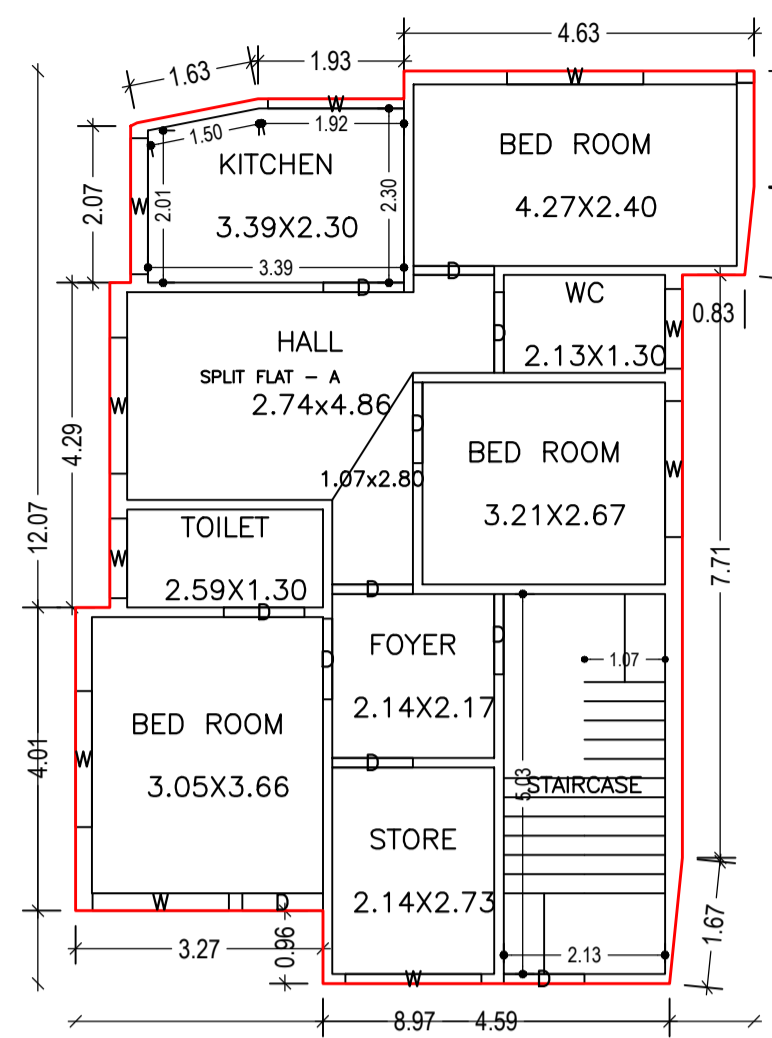

GROUND FLOOR PLAN (Proposed) (SCALE 1:100)

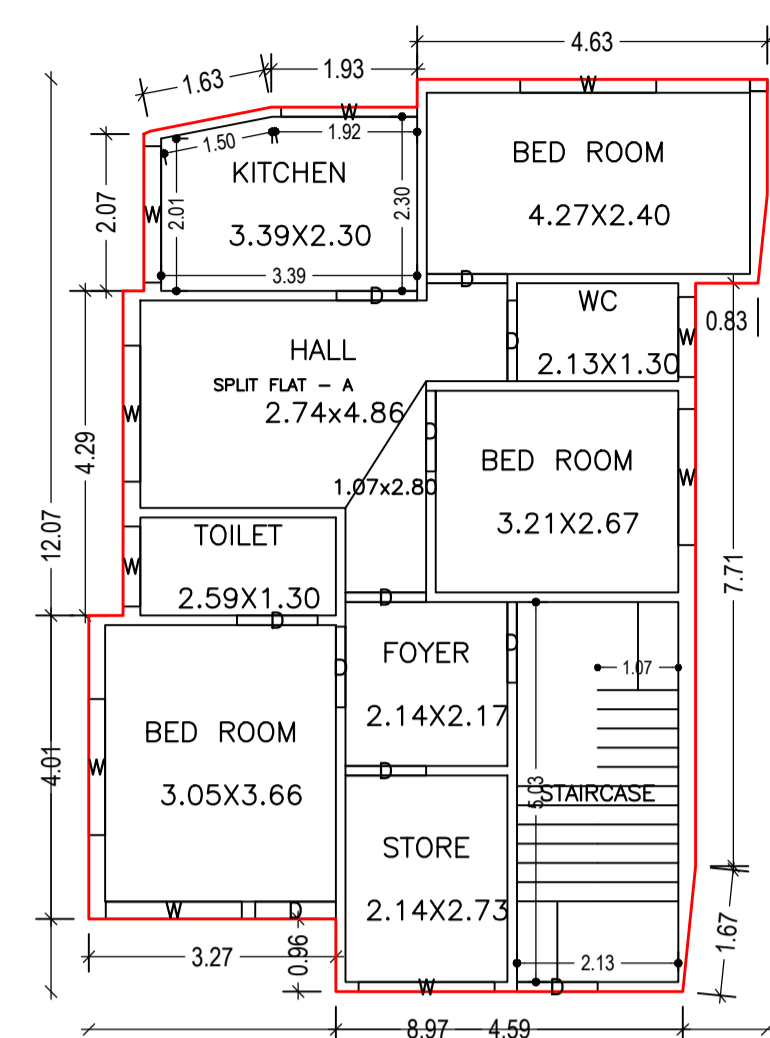

TYPICAL - 1 & 2 FLOOR PLAN (Proposed) (SCALE 1:100)

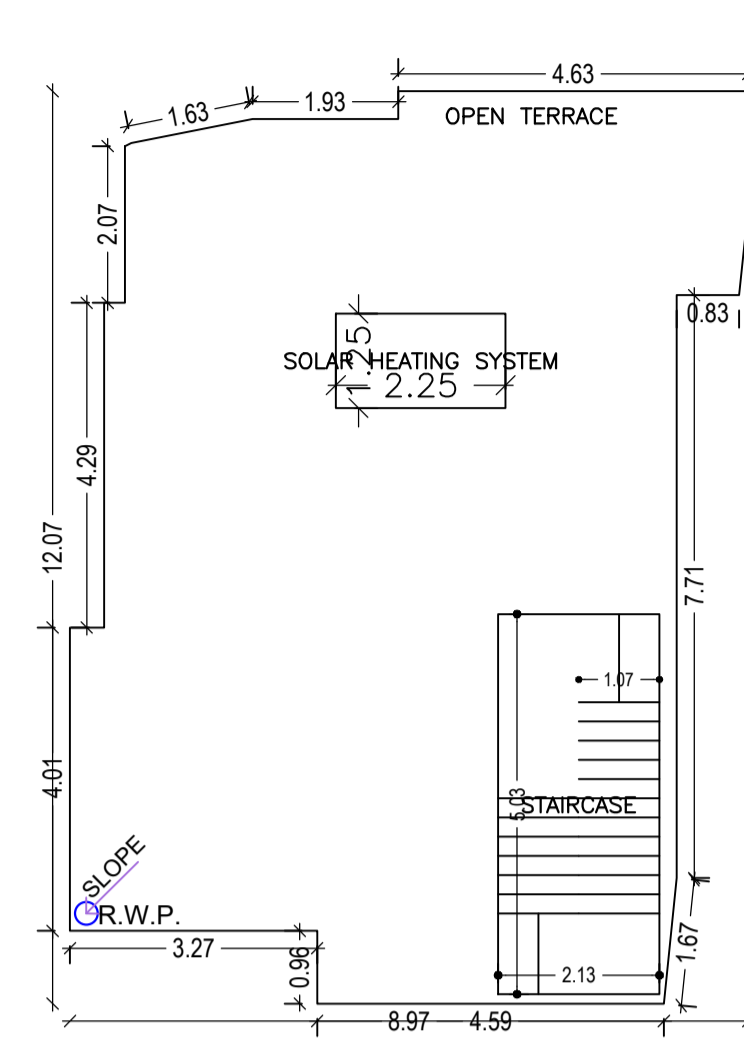

TERRACE FLOOR PLAN (SCALE 1:100)

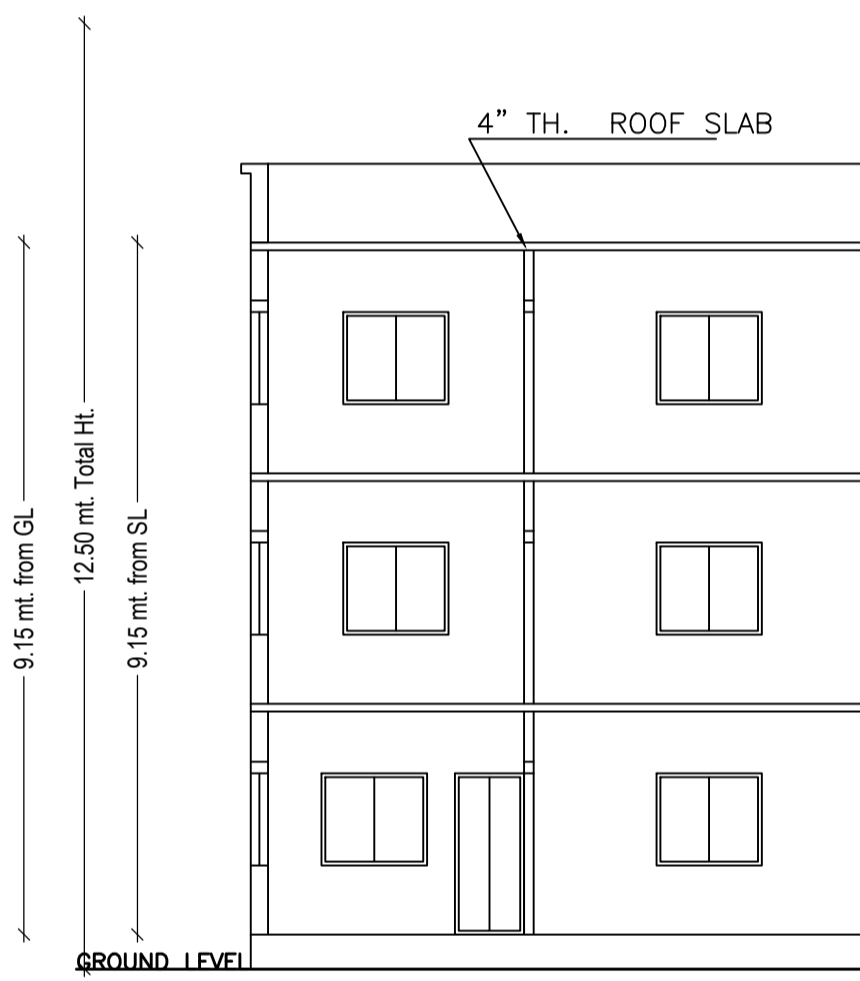

SECTION X-X

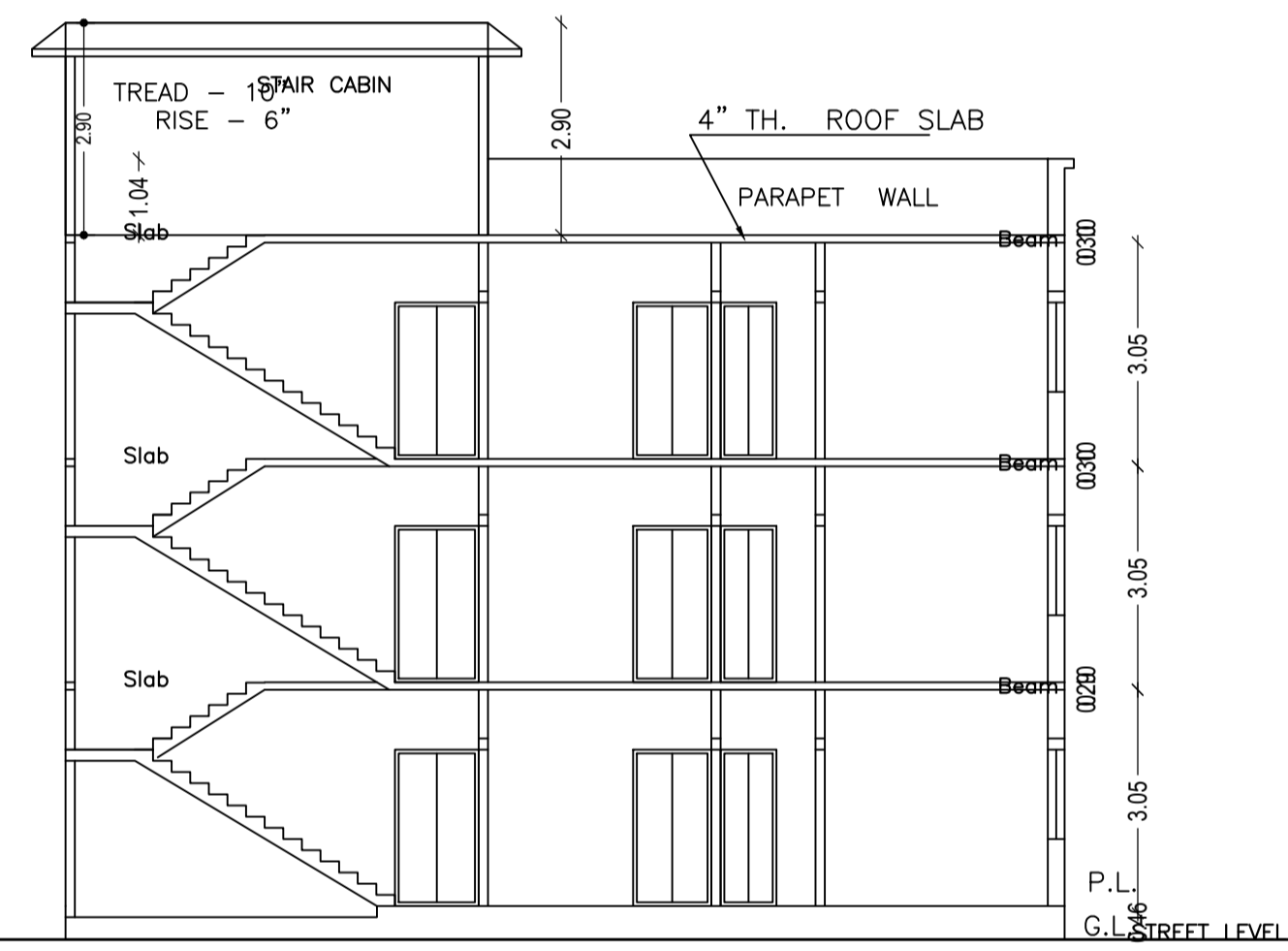

SECTION Y-Y

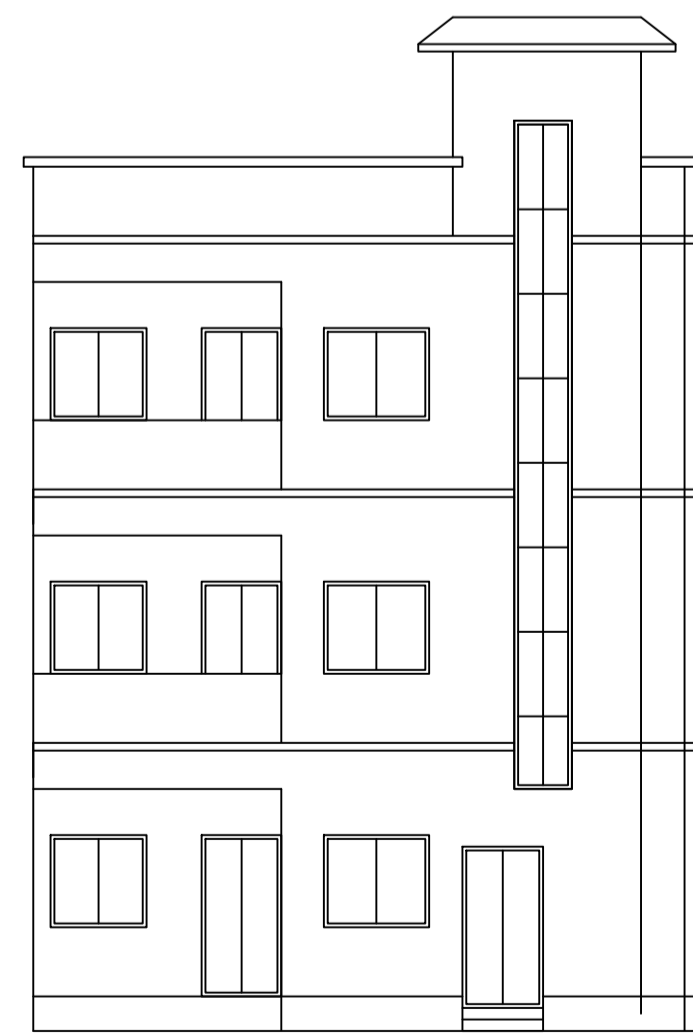

FRONT ELEVATION

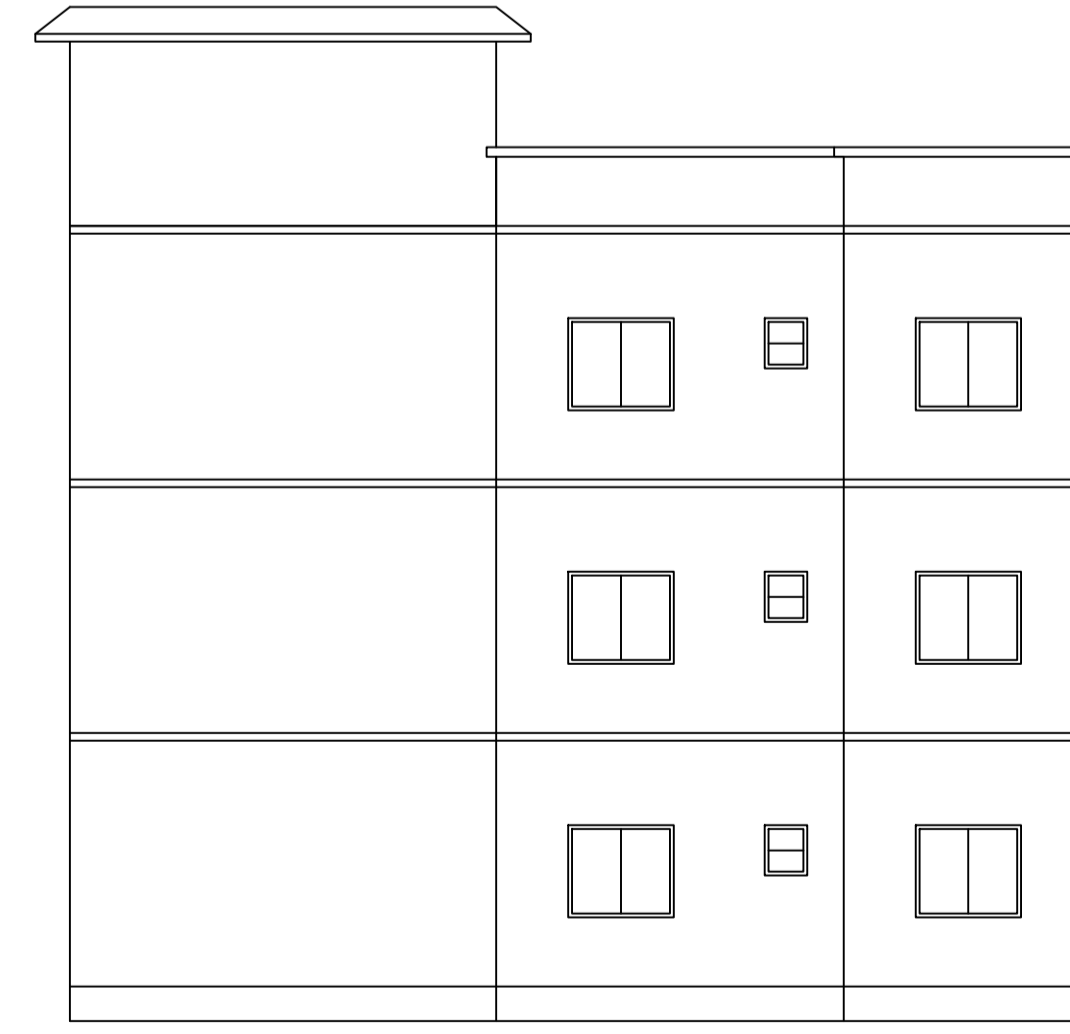

RIGHT SIDE ELEVATION

Proposal Basic Information

Proposal File No.	DMC/BP/0428/W19/2022
Owner Name	SANJIDA KHATOON
Khata No	old 71, new 304,451,
Plot No	old 2139,2148, new 3312,3304
Village Name	Panderpala
Use	Residential
SubUse	Bungalow/ Dwelling / Non Apartment

AREA STATEMENT	VERSION NO. : 1.0.66
DHANBAD MUNICIPAL CORPORATION	VERSION DATE: 16/10/2020
PROJECT DETAIL:	
Region: JHARKHAND URBAN LOCAL BODIES	Plot Use: Residential
District: DHANBAD	Plot SubUse: Bungalow/ Dwelling / Non Apartment
Authority: DHANBAD MUNICIPAL CORPORATION	PlotNearby/ReligiousStructure: NA
Inward_No: DMC/BP/0428/W19/2022	Plot/SubPlot No: old 2139,2148, new 3312,3304
Application Type: General Proposal	North: Road Width - 4.87
Project Type: Building Permission	South: Road Width - 4.26
Nature of Development: New	East: Plot No. - MOHAMMAD UMAR ALI
Location of Development Area: Old Area	West: Plot No. - LAND OF MD. ZAKEE KHAN AND TANSEEM FARZANA
AREA DETAILS:	SQ.MT.
AREA OF PLOT (Minimum)	(A)
NET AREA OF PLOT(Gross Plot Area - Deduction from Gross Plot area)	181.10
Deduction for Balance Plot Area(from Gross Plot Area)	
Common Plot	31.76
Total	31.76
BALANCE AREA OF PLOT(Net Plot Area - Recreational/Amenity space)	(A-Deductions)
Plot Area for FAR (Net Plot Area + Road Widening Area)	149.34
PLOT AREA FOR COVERAGE(Net Plot Area)	(A-Deductions)
Plot Area for FAR (Net Plot Area + Road Widening Area)	181.10
COVERAGE CHECK	
Permissible Coverage area ( 70.00 % )	126.77
Proposed Coverage Area ( 49.95 % )	90.46
Total Prop. Coverage Area ( 49.95 % )	90.46
Balance coverage area ( 20.05 % )	36.31
FAR CHECK	
Perm. FAR Area ( 1.500 )	271.65
Total Perm. FAR area	271.65
Residential FAR:	271.39
Proposed FAR Area	271.39
Total Proposed FAR Area	271.39
Consumed FAR (Factor)	1.50
Balance FAR Area	0.26
BUILT UP AREA CHECK	
Total Proposed BuiltUp Area	271.38
ARCHITECT (Regd)	AAKASH KUMAR
ENGINEER (Regd)	
SUPERVISOR (Regd)	
OWNER (Regd)	SANJIDA KHATOON
DEVELOPMENT AUTHORITY	LOCAL BODY

COLOR INDEX

PLOT BOUNDARY	Black
ABUTTING ROAD	Green
PROPOSED CONSTRUCTION	Red
COMMON PLOT	Yellow
ROAD WIDENING AREA	Blue
EXISTING (To be retained)	Orange
EXISTING (To be demolished)	Light Blue

Buildingwise Floor FAR Details

Floor Name	Building Name		Total	
	Proposed Built Up Area (Sq.mt.)	Proposed FAR Area (Sq.mt.)	Total Proposed Built Up Area (Sq.mt.)	Total FAR Area (Sq.mt.)
Ground Floor	90.46	90.46	90.46	90.46
First Floor	90.46	90.46	90.46	90.46
Second Floor	90.46	90.46	90.46	90.46
Terrace Floor	0.00	0.00	0.00	0.00
Total :	271.38	271.38	271.38	271.38

Building USE/SUBUSE Details

Building Name	Building Use	Building SubUse	Building Structure
A (BUILDING)	Residential	Bungalow/ Dwelling / Non Apartment	Non-Highrise

FAR & Tenement Details (Table 4c-1)

Building	No. of Same Bldg	Total Built Up Area (Sq.mt.)	Proposed FAR Area (Sq.mt.)	Total FAR Area (Sq.mt.)	Total Consumed Additional FAR Area (Sq.mt.)	Tnmt (No.)
A (BUILDING)	1	271.38	271.38	271.38	271.38	01
Grand Total :	1	271.38	271.38	271.38	271.38	01

UnitBUA Table for Building :A (BUILDING)

FLOOR	Name	UnitBUA Type	UnitBUA Area	Carpet Area	No. of Rooms	No. of Tenement
GROUND FLOOR PLAN	SPLIT FLAT - A	FLAT	271.39	271.28	9	1
TYPICAL - 1 & 2 FLOOR PLAN	SPLIT FLAT - A	FLAT	0.00	0.00	9	0
Total:	-	-	271.39	271.28	27	1

LTP NAME AND SIGNATURE	STRUCTURAL ENG'S NAME AND SIGNATURE	BUILDER NAME AND SIGNATURE	DIGITAL SIGNATURE
AAKASH KUMAR DMC/ENG/0019/2017			