

Proposal Basic Information	
Proposal File No.	DMC/BP/0435/W23/2022
Owner Name	SMT. KANCHAN DEVI
Khata No	76(OLD),91(NEW)
Plot No	165(OLD), 191(NEW)
Village Name	Kolakusma
Use	Residential
SubUse	Bungalow/ Dwelling / Non Apartment

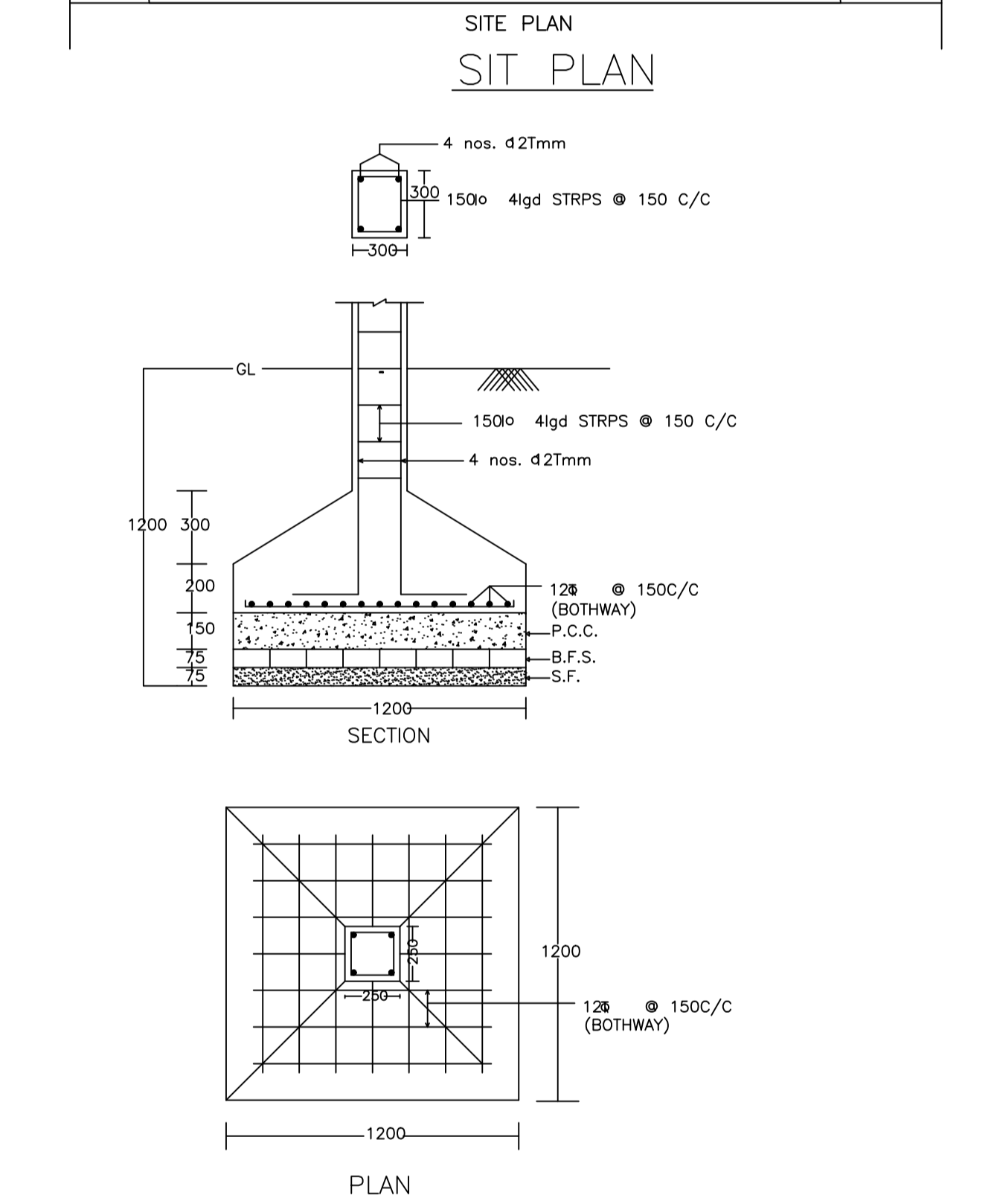
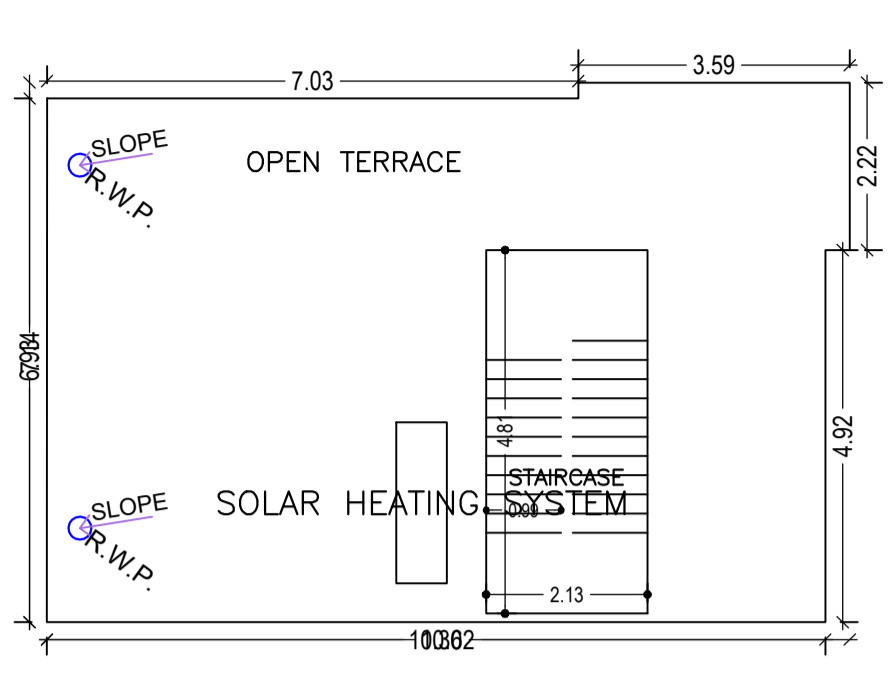
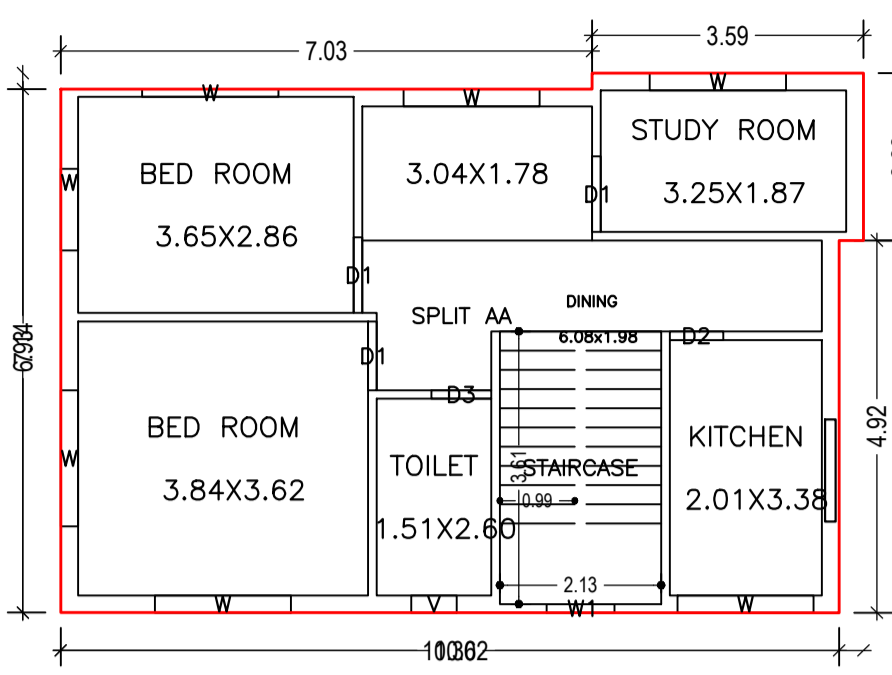
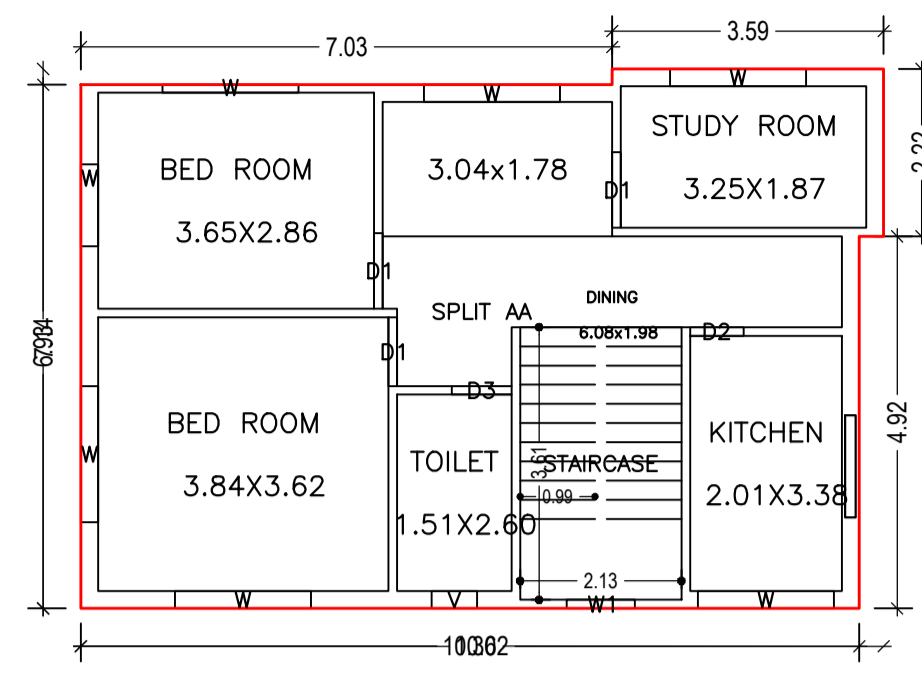
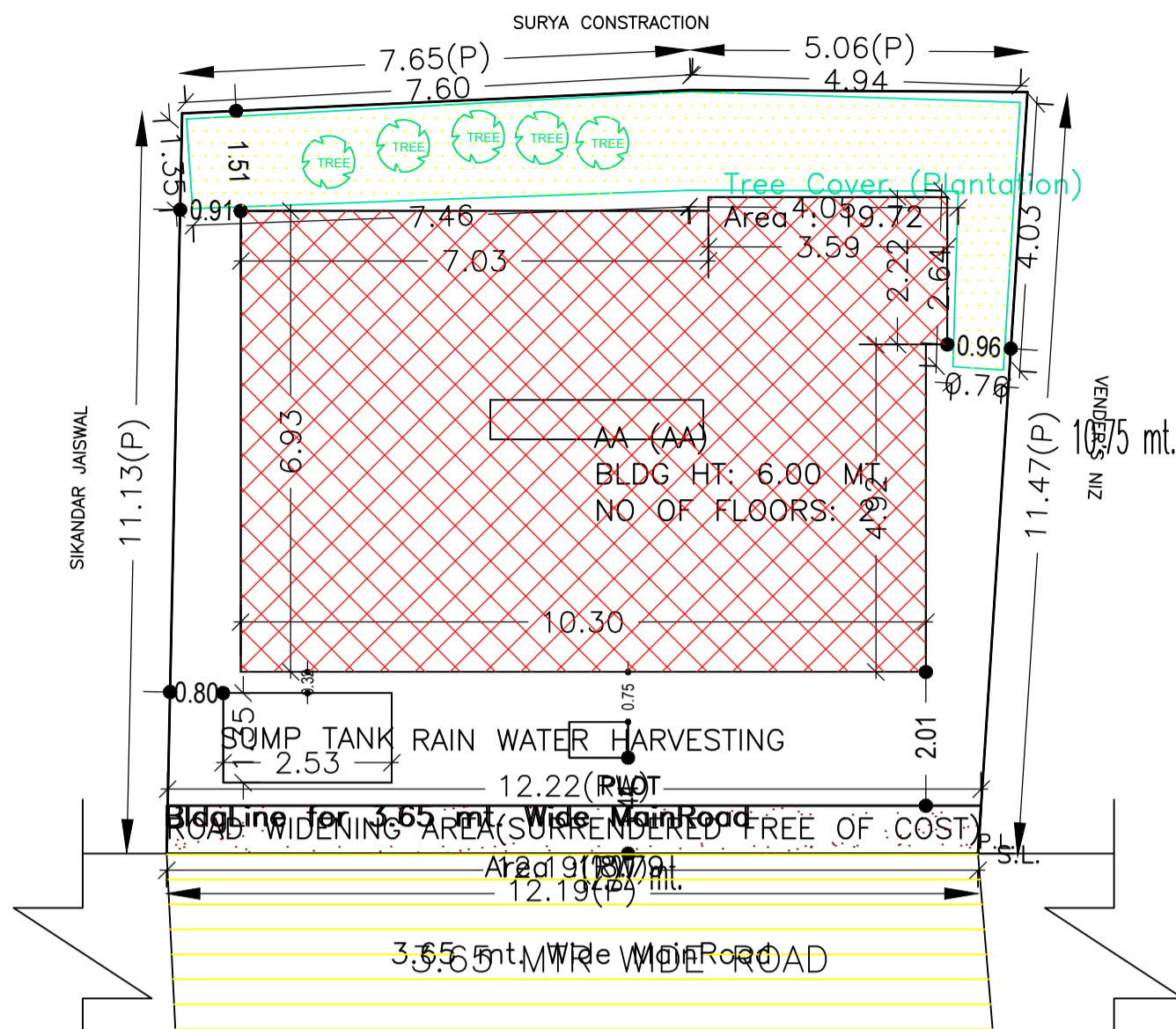

SCHEDULE OF DOOR:

BUILDING NAME	NAME	LENGTH	HEIGHT	NOS
AA (AA)	D2	0.71	2.10	02
AA (AA)	D3	0.79	2.10	02
AA (AA)	D1	0.91	2.10	02
AA (AA)	D1	1.00	2.10	04

SCHEDULE OF WINDOW/VENTILATION:

BUILDING NAME	NAME	LENGTH	HEIGHT	NOS
AA (AA)	V	0.60	1.20	02
AA (AA)	W1	0.90	1.20	02
AA (AA)	W	1.08	1.20	02
AA (AA)	W	1.80	1.20	12

UnitBUA Table for Building :AA (AA)

FLOOR	Name	UnitBUA Type	UnitBUA Area	Carpet Area	No. of Rooms	No. of Tenement
GROUND FLOOR PLAN	SPLIT AA	FLAT	145.42	145.05	6	1
FIRST FLOOR PLAN	SPLIT AA	FLAT	0.00	0.00	6	0
Total:	-	-	145.42	145.05	12	1

FAR & Tenement Details (Table 4c-1)

Building	No. of Same Bldg	Total Built Up Area (Sq.mt.)	Proposed FAR Area (Sq.mt.) Resi.	Total FAR Area (Sq.mt.)	Total Consumed Additional FAR Area (Sq.mt.)	Trmt (No.)
AA (AA)	1	145.42	145.42	145.42	145.42	01
Grand Total:	1	145.42	145.42	145.42	145.42	01

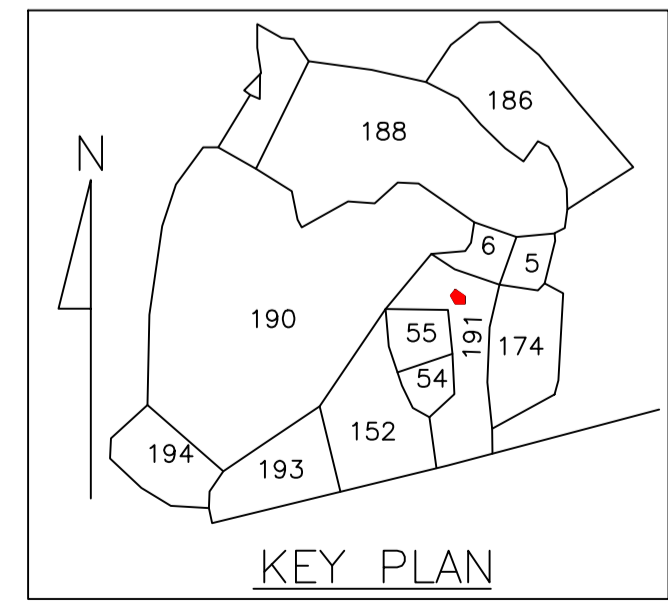
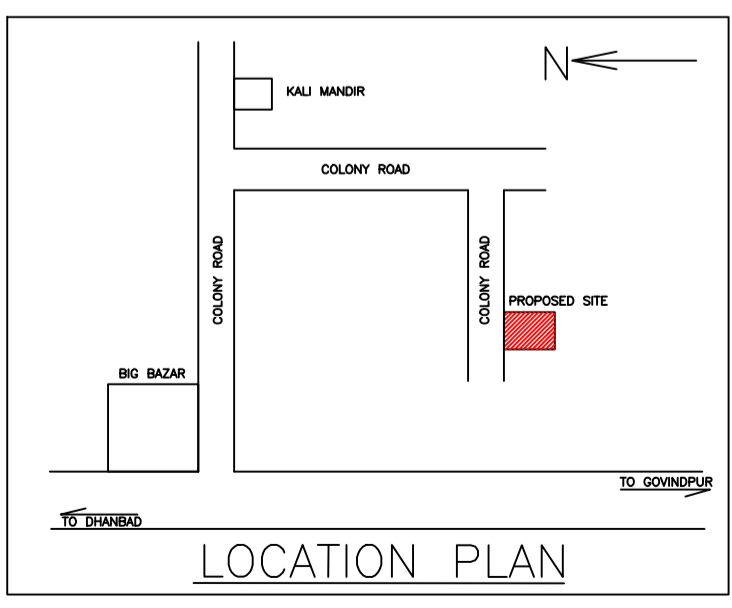
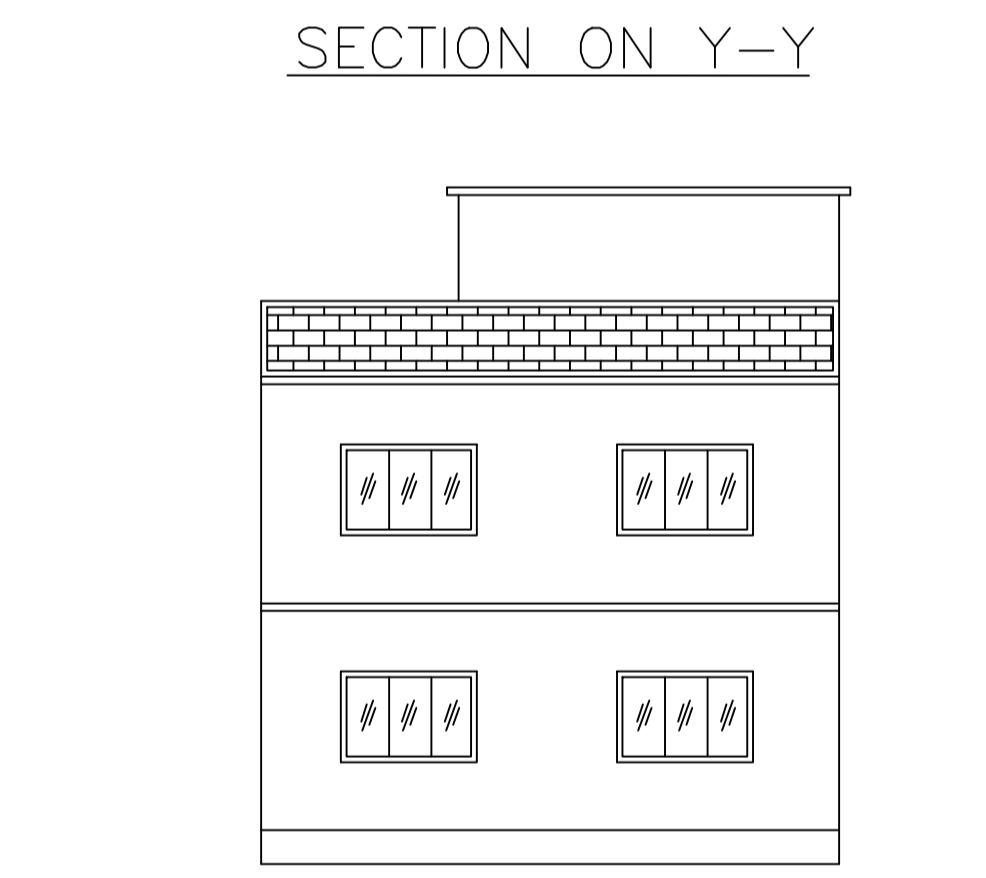
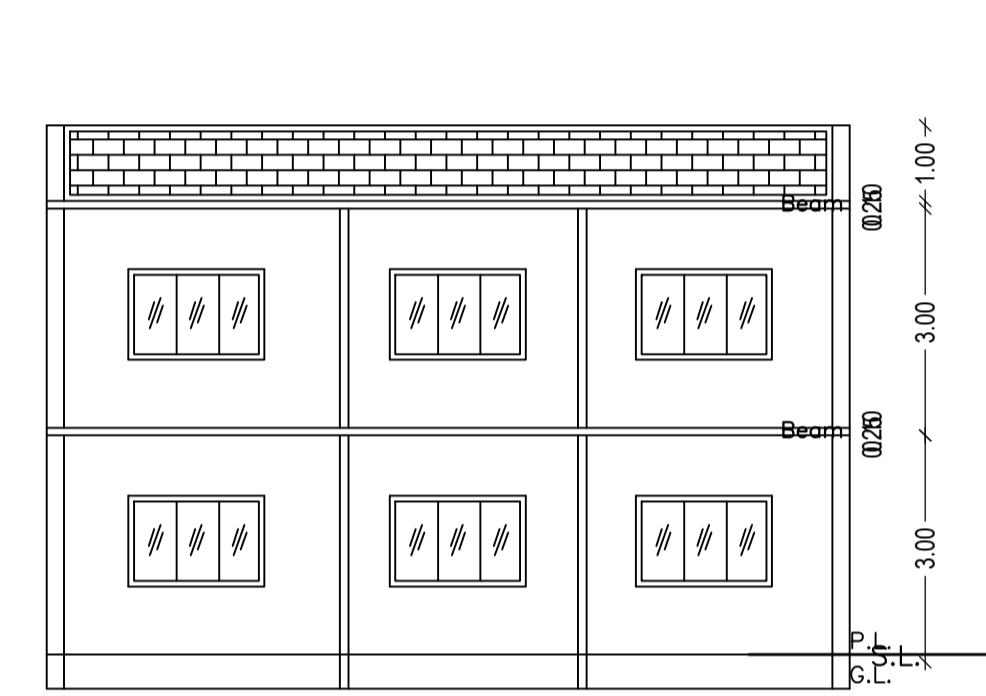
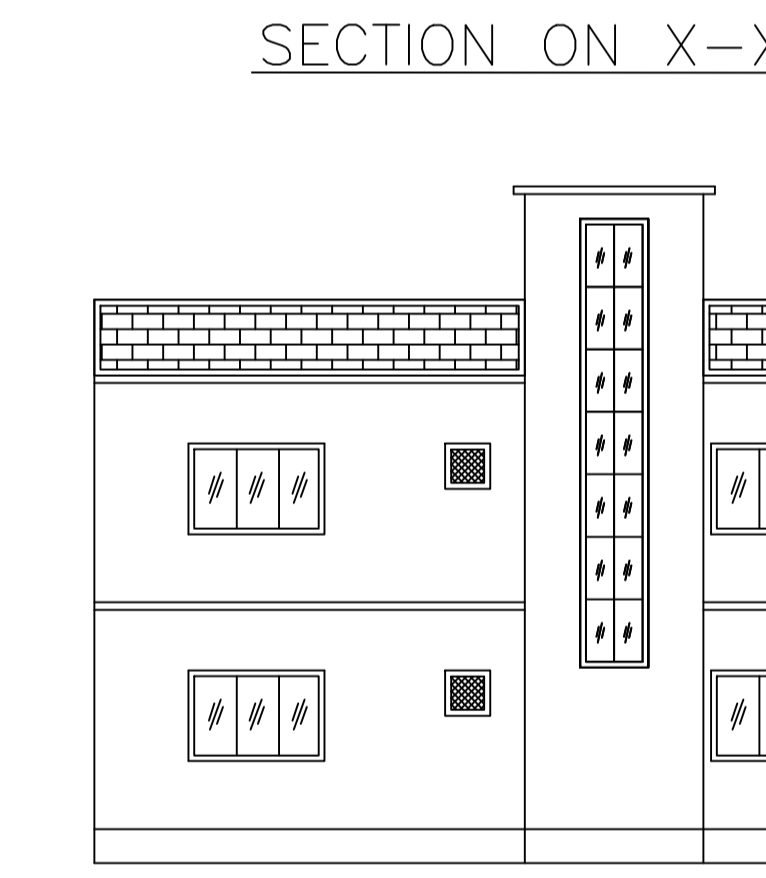
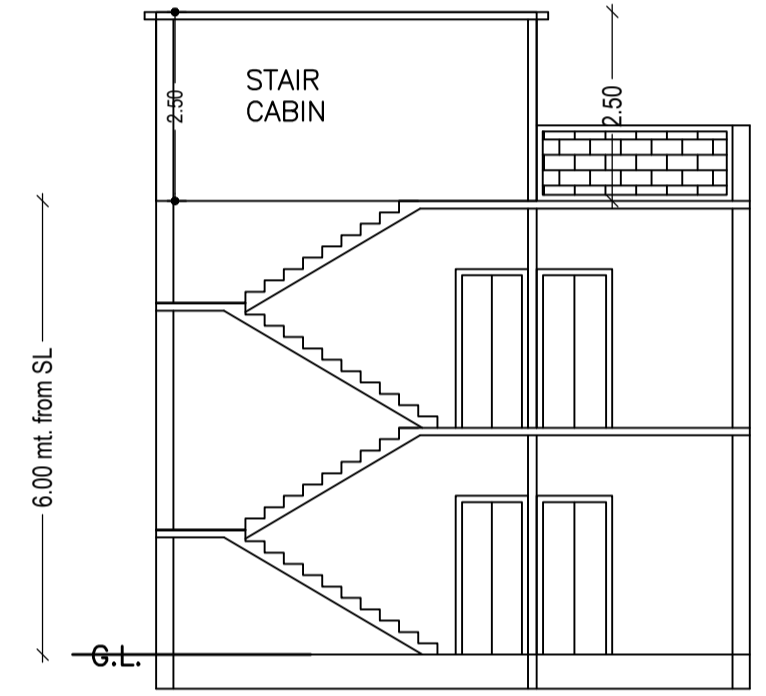
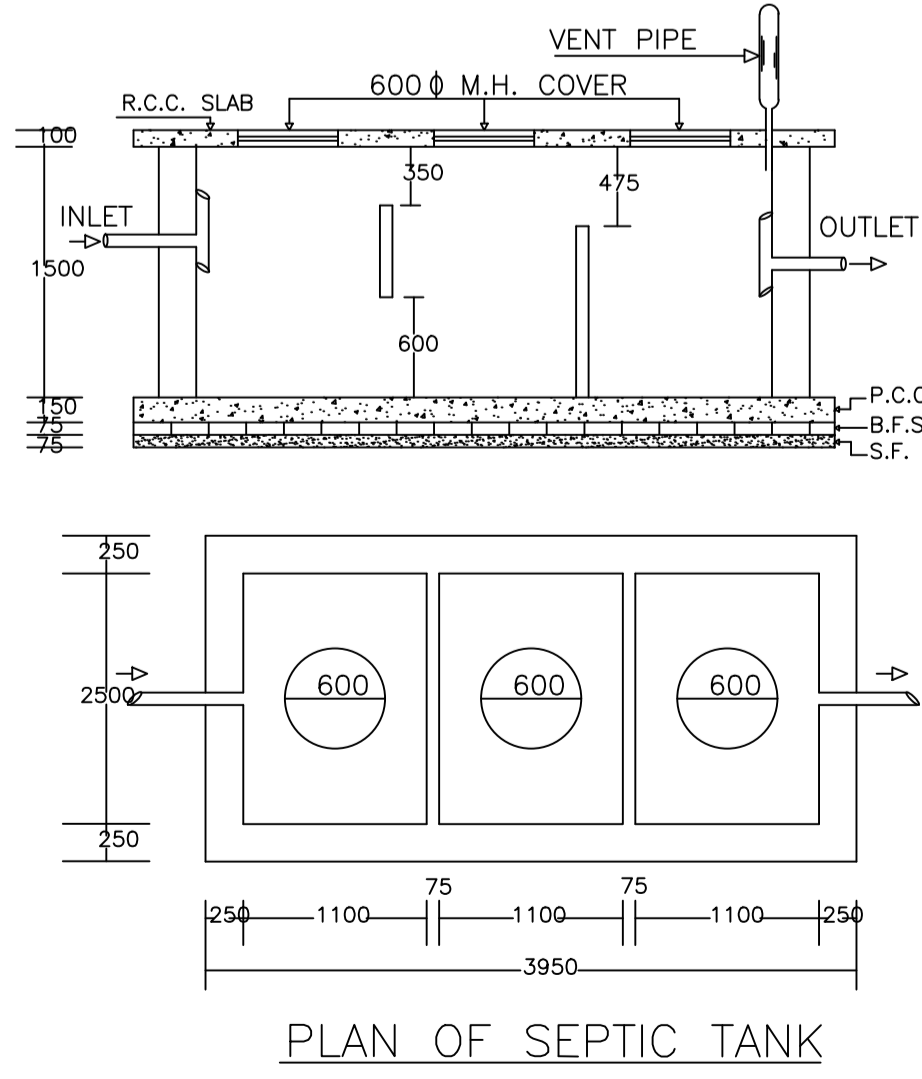

AREA STATEMENT		VERSION NO.:	1.0.66
DHANBAD MUNICIPAL CORPORATION		VERSION DATE:	16/10/2020
PROJECT DETAIL:			
Region: JHARKHAND URBAN LOCAL BODIES	Plot Use: Residential		
District: DHANBAD	Plot SubUse: Bungalow/ Dwelling / Non Apartment		
Authority: DHANBAD MUNICIPAL CORPORATION	PlotNearby/ReligiousStructure: NA		
Inward No: DMC/BP/0435/W23/2022	Plot/SubPlot No: 165(OLD), 191(NEW)		
Application Type: General Proposal	North: Plot No. - SURYA CONSTRUCTION		
Project Type: Building Permission	South: Road Width - 3.65 WIDE ROAD		
Nature of Development: New	East: Plot No. - VENDOR'S NIZ		
Location of Development Area: Old Area	West: Plot No. - SIKANDAR JAISWAL		
AREA DETAILS:			SQ.MT.
AREA OF PLOT (Minimum)	(A)		141.40
Deduction for NetPlot Area			
Surrender Free of Cost			8.79
Total			8.79
NET AREA OF PLOT(Gross Plot Area - Deduction from Gross Plot area)	(A-Deductions)		132.61
Deduction for Balance Plot Area(from Gross Plot Area)			
Surrender Free of Cost			8.79
Common Plot			19.72
Total			28.51
BALANCE AREA OF PLOT (Net Plot Area - Recreational/Amenity space)	(A-Deductions)		112.89
PLOT AREA FOR COVERAGE(Net Plot Area)	(A-Deductions)		132.61
Plot Area for FAR (Net Plot Area + Road/Widening Area)	(A-Deductions)		141.40
COVERAGE CHECK			
Permissible Coverage area (70.00 %)			92.83
Total Prop. Coverage Area (54.83 %)			72.71
Total Prop. Coverage Area (54.83 %)			72.71
Balance coverage area (15.17 %)			20.12
FAR CHECK			
Perm. FAR Area (1.500)			212.10
Total Perm. FAR area			212.10
Residential FAR			145.42
Proposed FAR Area			145.42
Total Proposed FAR Area			145.42
Consumed FAR (Factor)			1.03
Balance FAR Area			66.68
BUILT UP AREA CHECK			
Total Proposed BuiltUp Area			145.42
ARCHITECT (Regd)		AMRESH KUMAR BHARTI	
ENGINEER (Regd)			
SUPERVISOR (Regd)			
OWNER (Regd)		SMT. KANCHAN DEVI	
DEVELOPMENT AUTHORITY		LOCAL BODY	

COLOR INDEX	
PLOT BOUNDARY	Black
ABUTTING ROAD	Green
PROPOSED CONSTRUCTION	Red
COMMON PLOT	Yellow
ROAD WIDENING AREA	Blue
EXISTING (To be retained)	Light Blue
EXISTING (To be demolished)	Dark Blue

Buildingwise Floor FAR Details

Floor Name	Building Name		Total	
	Proposed Built Up Area (Sq.mt.)	Proposed FAR Area (Sq.mt.)	Total Proposed Built Up Area (Sq.mt.)	Total FAR Area (Sq.mt.)
Ground Floor	72.71	72.71	72.71	72.71
First Floor	72.71	72.71	72.71	72.71
Terrace Floor	0.00	0.00	0.00	0.00
Total:	145.42	145.42	145.42	145.42

Building USE/SUBUSE Details

Building Name	Building Use	Building SubUse	Building Structure
AA (AA)	Residential	Bungalow/ Dwelling / Non Apartment	Non-Highrise

Building :AA (AA)

Floor Name	Total Built Up Area (Sq.mt.)	Proposed FAR Area (Sq.mt.) Resi.	Total FAR Area (Sq.mt.)	Total Consumed Additional FAR Area (Sq.mt.)	Trmt (No.)
Ground Floor	72.71	72.71	72.71	72.71	01
First Floor	72.71	72.71	72.71	72.71	00
Terrace Floor	0.00	0.00	0.00	0.00	00
Total:	145.42	145.42	145.42	145.42	01
Total Number of Same Buildings :	1				
Total :	145.42	145.42	145.42	145.42	01

LTP NAME AND SIGNATURE	STRUCTURAL ENG'S NAME AND SIGNATURE	BUILDER NAME AND SIGNATURE	DIGITAL SIGNATURE
AMRESH KUMAR BHARTI DMC/ENG/0022/2016			