

Project Title :VANDANA SINGH

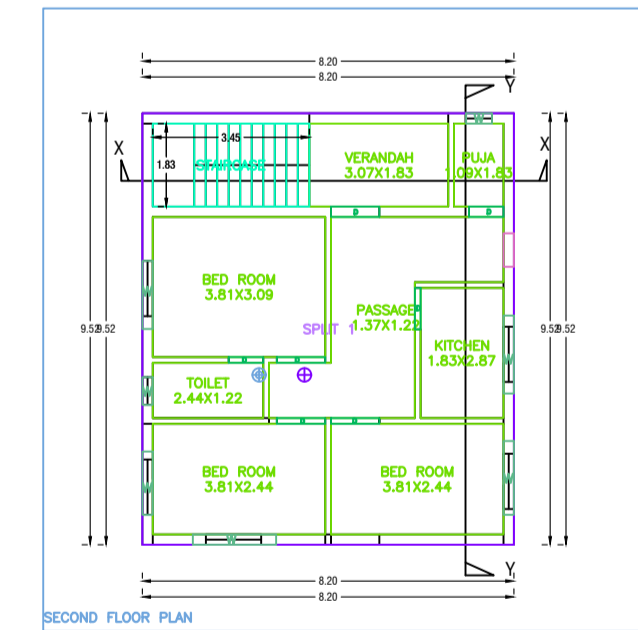
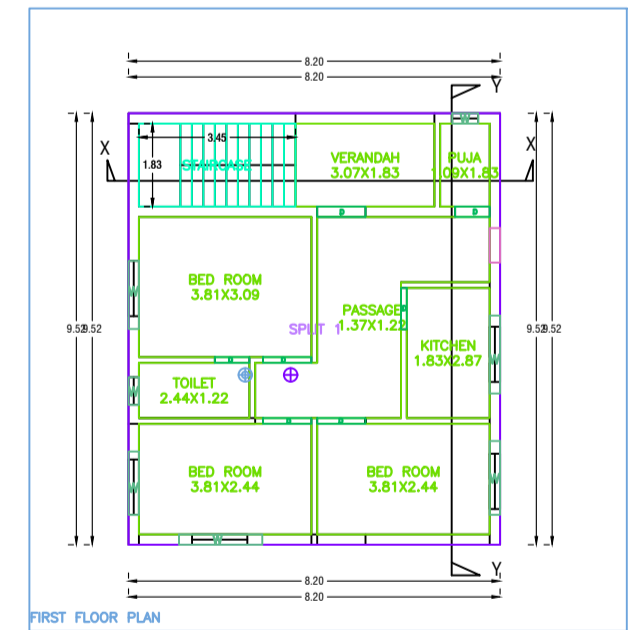
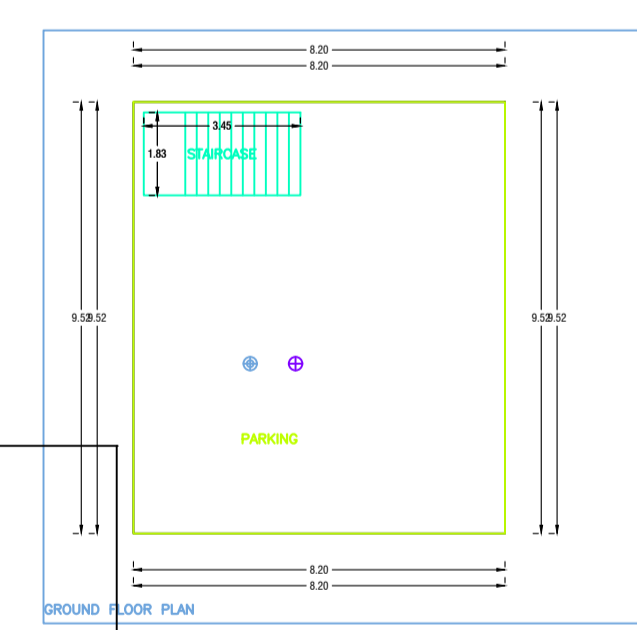
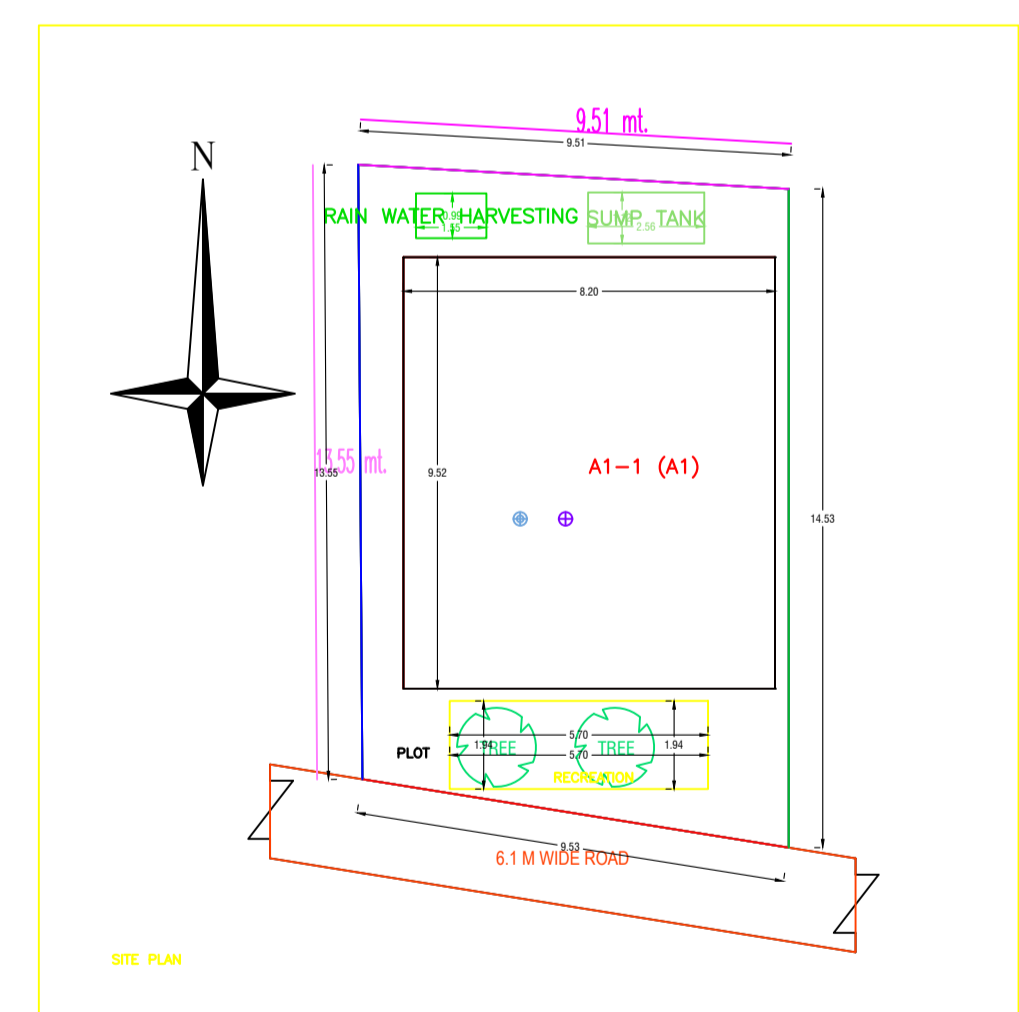
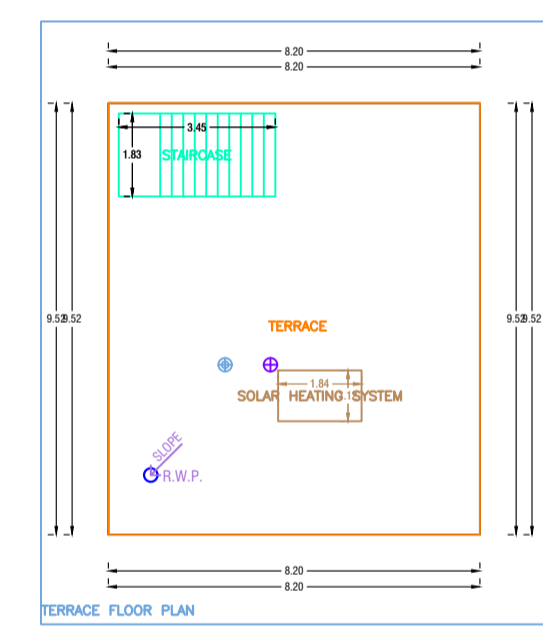
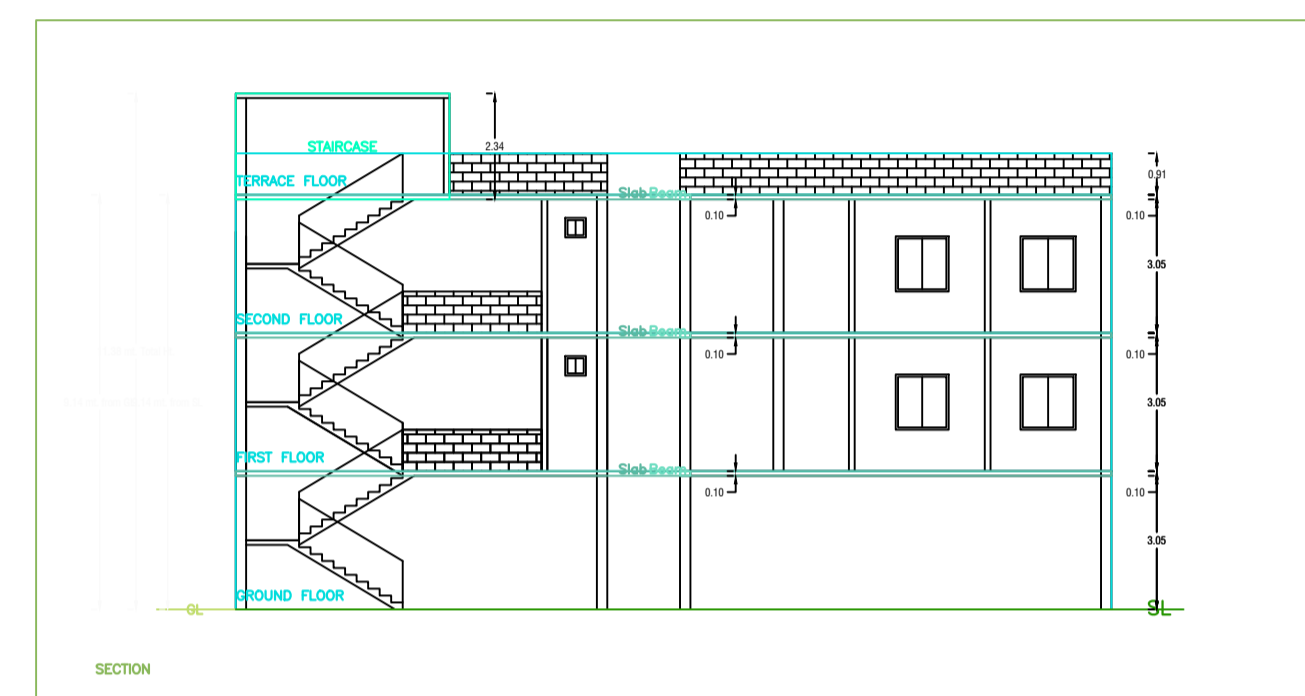
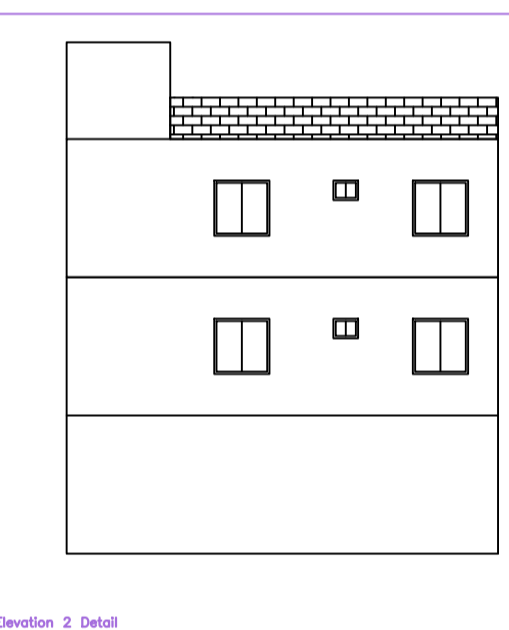
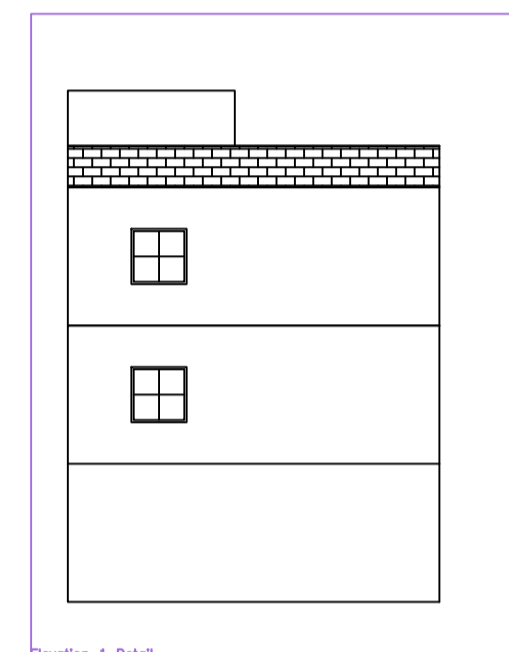
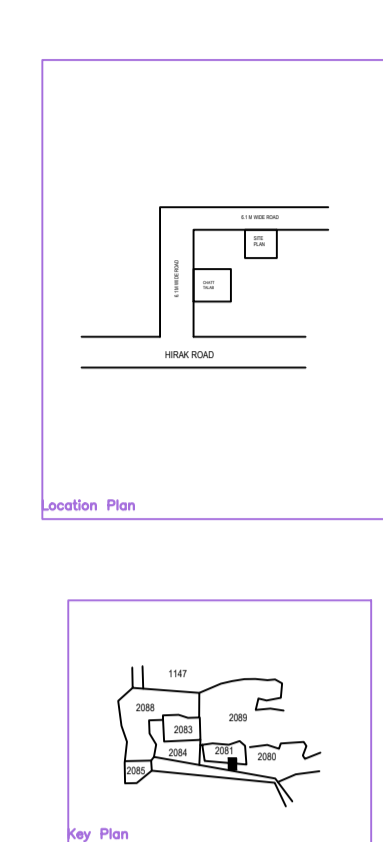
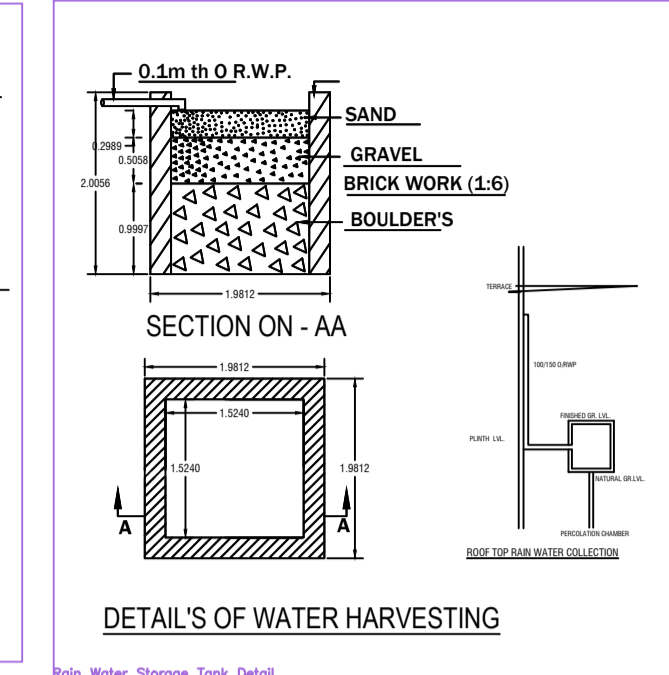
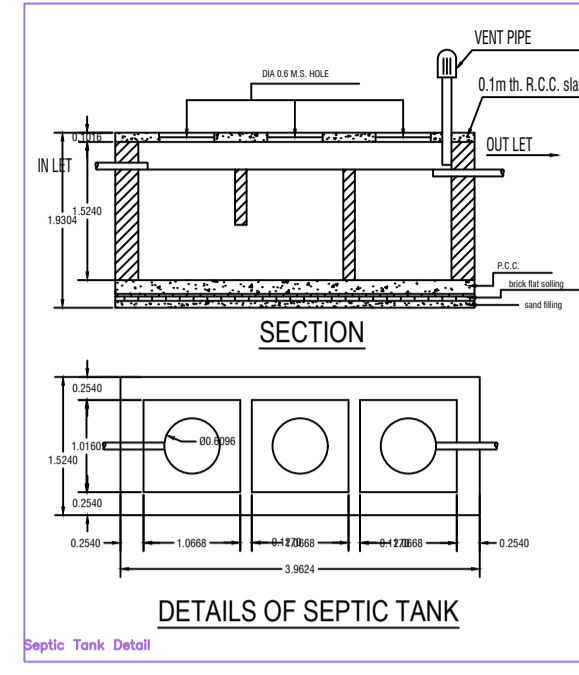
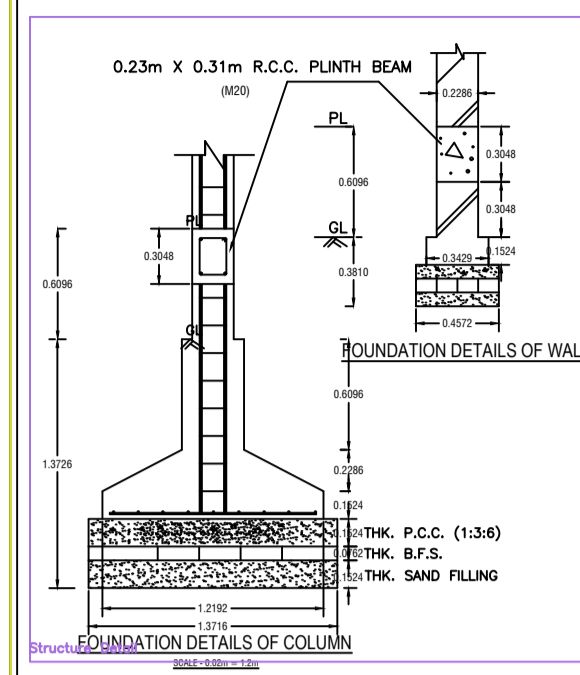

BRIEF SPECIFICATION

FOUNDATION - R.C.C. (1:1.5:3) Column footing foundation.
PLINTH - 12"th R.C.C. (1:1.5:3) all round on plinth level.
FLOORING - 1.5"th Marble, flooring over 3"th P.C.C. (1:3:6).
SUPER STRUCTURE - First class brick work in cement mortar (1:6).
SLAB, BEAM, stairs & LINTEL - All R.C.C. work (1:1.5:3).
WOOD WORK - All door & window frames of sal wood.
PLASTERING - 12mm cement plaster (1:6) both side.

SCHEDULE

D1 - 1.07 X 2.13	W - 0.9 x 1.22
D2 - 0.9 X 2.13	W1 - 1.22 x 1.22
D3 - 0.76 x 2.13	W2 - 1.5 x 1.22
CG - 1.22 x 2.13	V - 0.61 x 0.61

SIG. OF OWNER

SIG. OF ENGINEER

Building A1 (A1)

Floor Name	Total Built Up Area (Sq. mt.)	Deductions (Area in Sq. mt.)	Proposed FAR	Add Area in FAR (Sq. mt.)	Total FAR Area (Sq. mt.)	Total No. of Units
Ground Floor	78.00	71.68	0.00	0.00	4.32	00
First Floor	78.00	0.00	78.00	0.00	78.00	01
Second Floor	78.00	0.00	78.00	0.00	78.00	00
Veranda Floor	0.00	0.00	0.00	0.00	0.00	00
Total	234.00	71.68	156.00	0.00	184.32	01
Total Number of Same Buildings	1					
Total	234.00	71.68	156.00	0.00	184.32	01

SCHEDULE OF JOINERY:

BUILDING NAME	NAME	LENGTH	HEIGHT	NO. OF
A1 (A1)	D	0.76	2.10	04
A1 (A1)	D	0.91	2.10	02
A1 (A1)	D	1.07	2.10	08
Total				14

SCHEDULE OF JOINERY:

BUILDING NAME	NAME	LENGTH	HEIGHT	NO. OF
A1 (A1)	W	0.57	1.20	02
A1 (A1)	W	0.91	1.20	02
A1 (A1)	W	1.40	1.20	02
A1 (A1)	W	1.50	1.20	02
A1 (A1)	W	1.83	1.20	02
A1 (A1)	W	1.72	1.20	02
A1 (A1)	W	1.04	1.20	02
Total				14

UNIBUA Table for Building A1 (A1)

FLOOR	Name	UNIBUA Type	UNIBUA Area	Carpet Area	No. of Rooms	No. of Tenement
FIRST FLOOR	SPLIT 1	FLAT	156.00	156.00	01	1
VERANDA FLOOR	-	-	0.00	0.00	00	0

ANEX STATEMENT

ANEX STATEMENT	SHANABAD MUNICIPAL CORPORATION	VERSION NO. 1.3.0
PROJECT DETAIL		VERSION DATE: 10/02/2020
Project No.	SHANABAD URBAN LOCAL BODIES	Plot Use: Residential
Project Name	SHANABAD URBAN LOCAL BODIES	Plot Section: Residential Dwelling / Non Apartment
Project Type	General Purpose	Land Use Zone: NA
Project Type	Building Permission	Building Area: -
Nature of Development	New	Revenue Survey No/Survey No.:
Location	05 Area	Thane No.:
Sub Location	NA	Holding No.:
Thane/Block Name	-	Khata No.:
Ward No.	-	North:
Road/Street	-	East:
		West:

AREA DETAILS

AREA OF PLOT (Minimum)	(A)	132.88
Plot Area (Gross Plot Area)	(A)	132.88
Deduction from Gross Plot Area	(A-Deductions)	-
Deductions for Balance Plot Area (from Gross Plot Area)		-
Total		132.88
Minimum Plot Area (from Plot Area)	(A-Deductions)	121.99
Plot Area for Coverage (Plot Area)	(A-Deductions)	132.88
Plot Area for FAR (from Plot Area)	(A-Deductions)	132.88
COVERAGE CHECK		
Proposed Coverage Area (50.75%)		78.00
Total Coverage Area (50.75%)		78.00
PERCENTAGE		
Proposed Area of FAR		162.32
Total Area of FAR		162.32
BUILT UP CHECK		
Total Proposed Built Up Area		234.00
CHECK: BUILT UP SUPERSEDES (Flag)		OWNER
DEVELOPMENT AUTHORITY		LOCAL BODY

COLOR INDEX

Color Index:	
Proposed Work (Coverage Area)	Green
Existing (To be retained)	Red
Existing (To be demolished)	Yellow

PARKING CALCULATION:

Parking Type	Prop. No.	Prop. Area
Other Parking	1	71.68
Total Area		71.68

MARGIN DETAIL:

Building / Wing	Road Name	Front Margin	Rear Margin	Side1 Margin	Side2 Margin
A1 (A1)	6.1 M WIDE ROAD	2.11	1.52	0.92	0.30

FAR & Tenement Details (Table 4c-1)

Building	No. of Cars (Bq)	Total Built Up Area (Sq. mt.)	Deductions (Area in Sq. mt.)	Proposed FAR (Sq. mt.)	Add Area in FAR (Sq. mt.)	Total FAR Area (Sq. mt.)	Total FAR (No.)
A1 (A1)	1	234.00	71.68	156.00	0.00	156.00	01
Grand Total	1	234.00	71.68	156.00	0.00	156.00	01