

Project Title :RAJESH KUMAR BELDAR AND KUNDAN KUMAR BELDAR

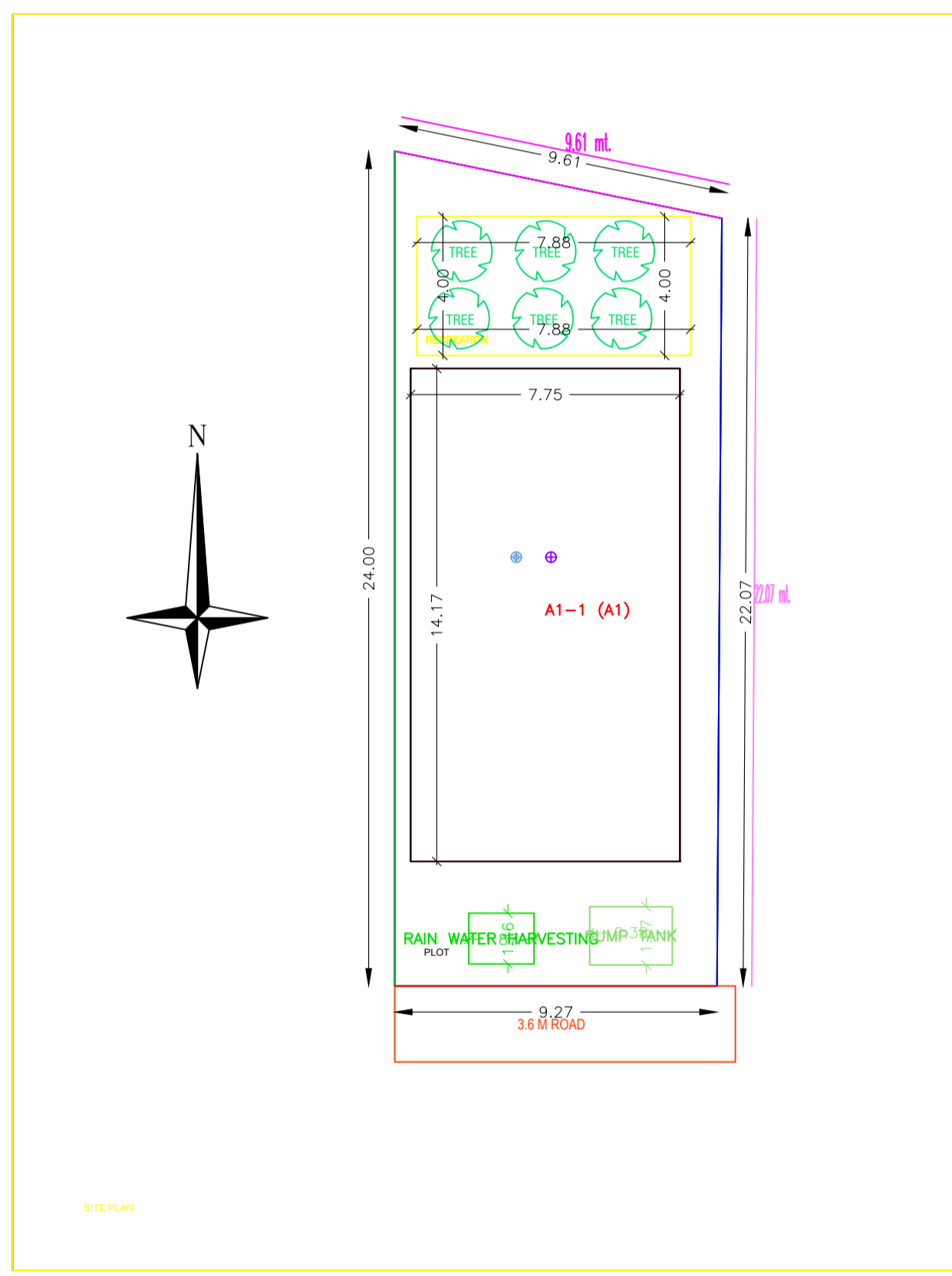
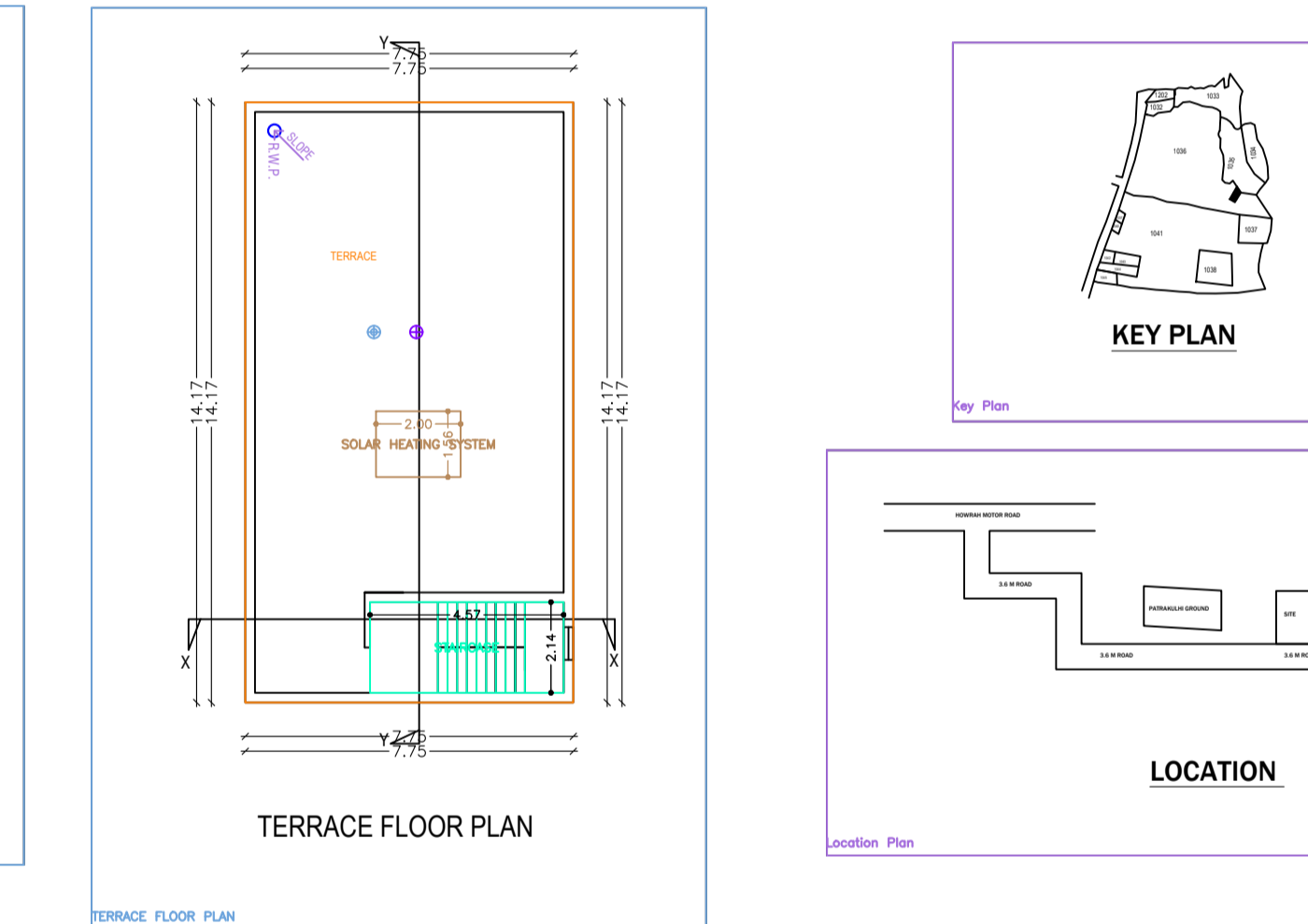
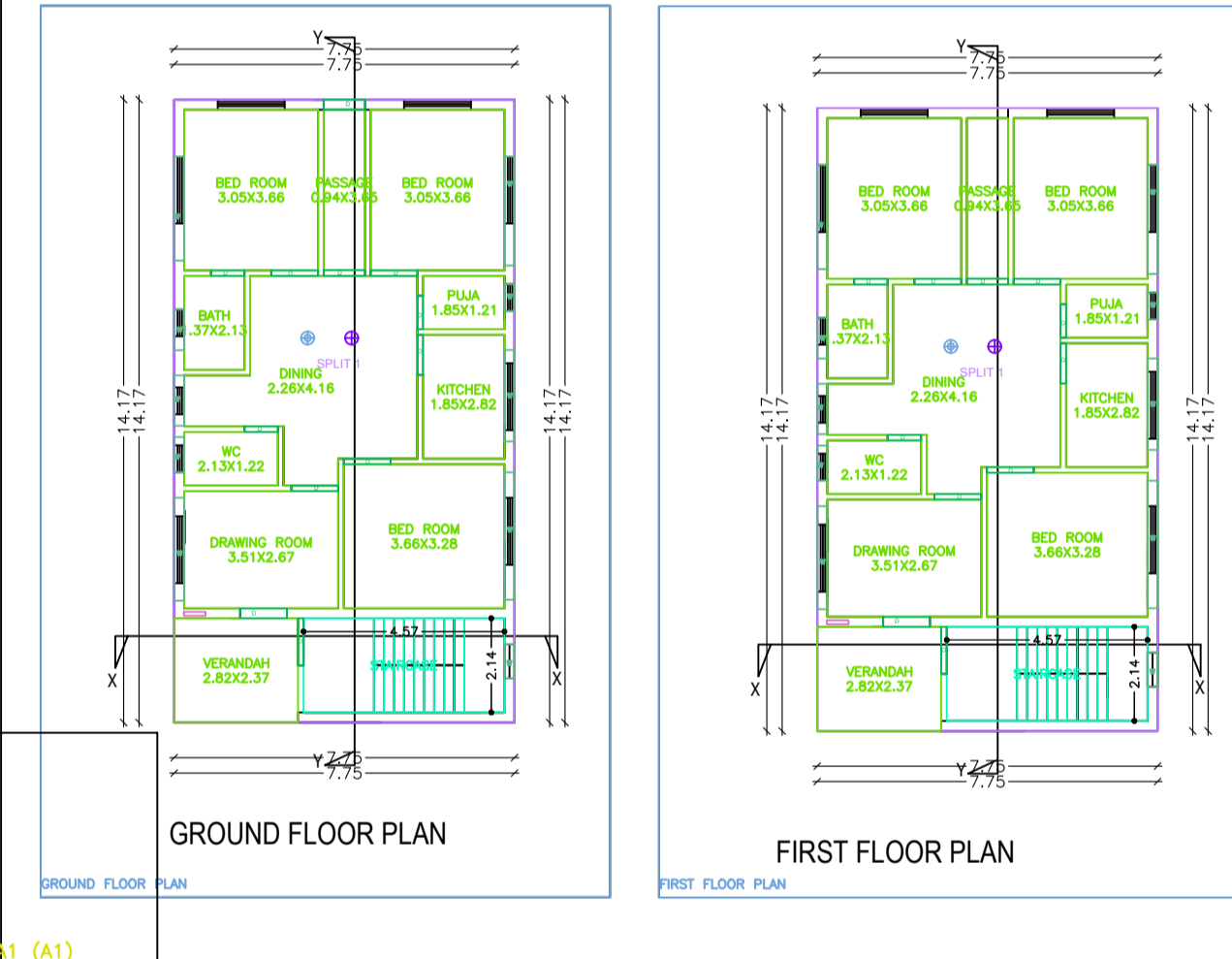
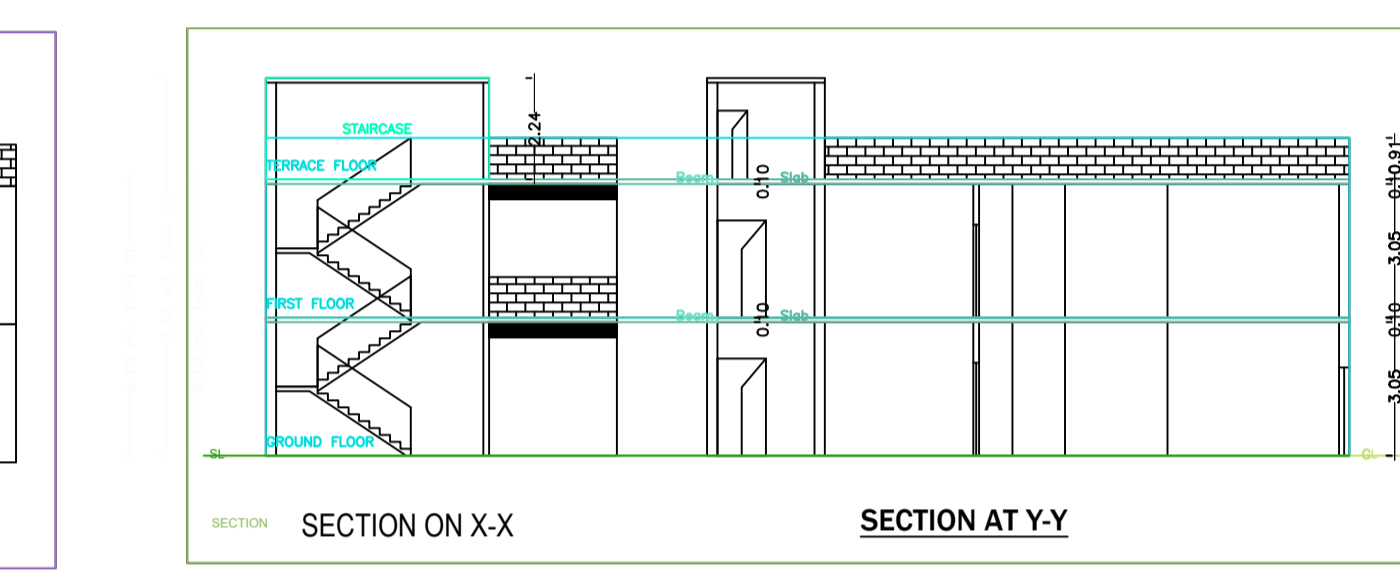
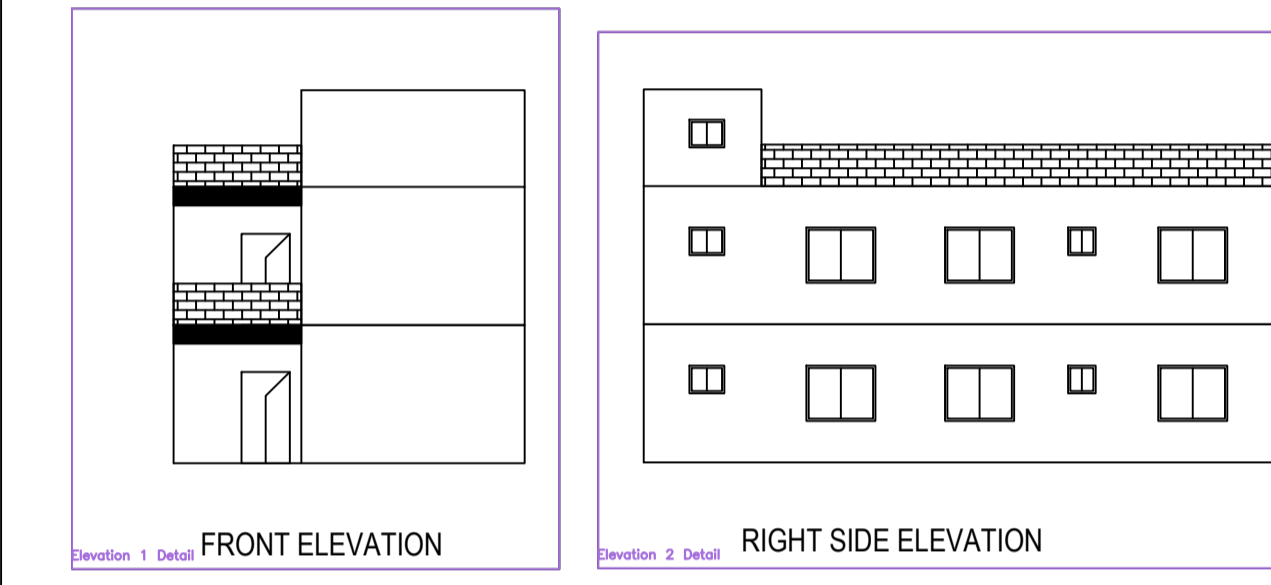
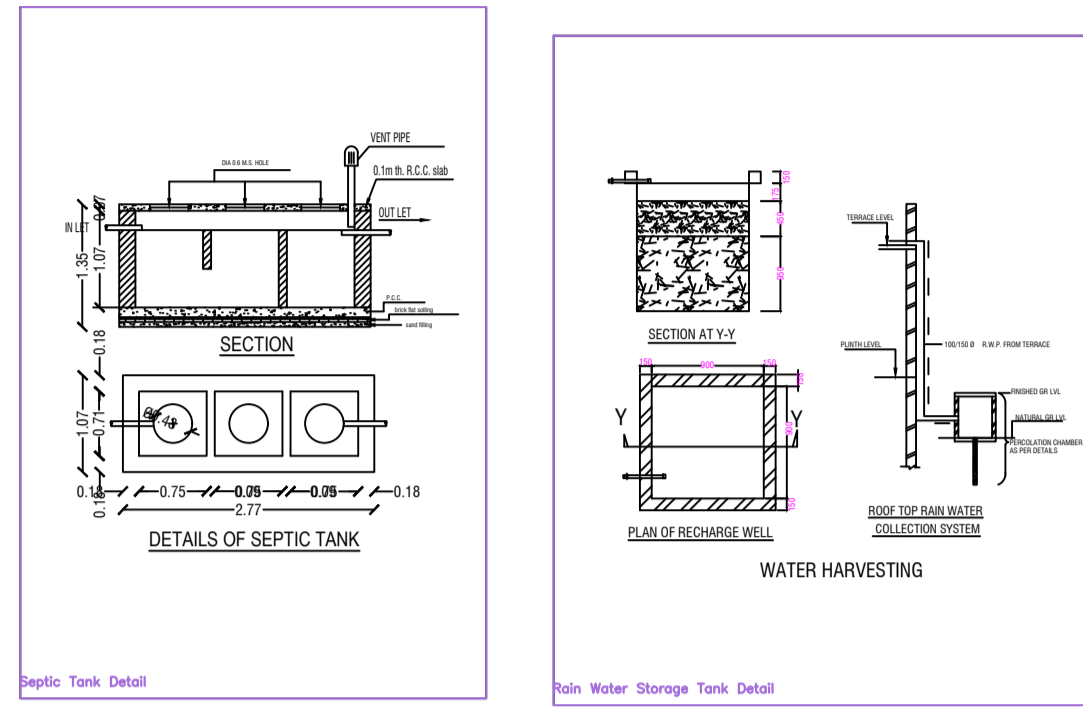
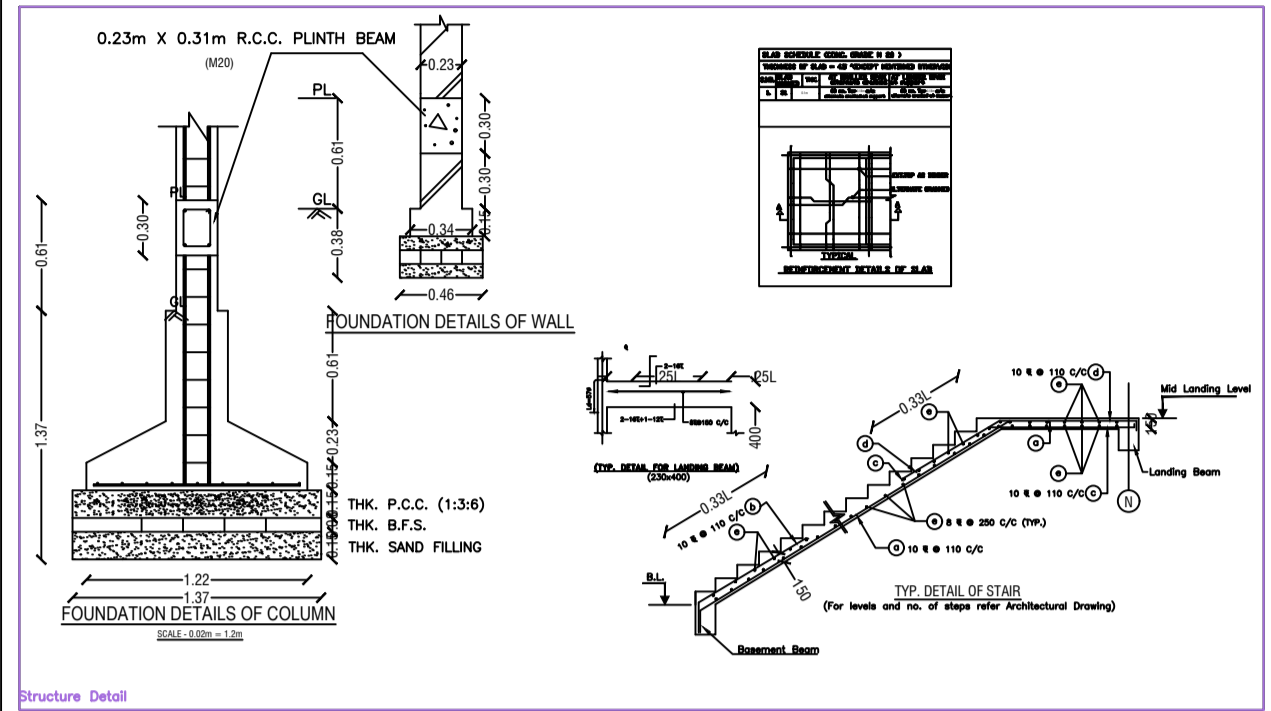

BRIEF SPECIFICATION

FOUNDATION - R.C.C. (1:1.5:3) Column footing foundation.
PLINTH - > 12"th R.C.C. (1:1.5:3) all round on plinth level.
FLOORING - 1.5"th Marble flooring over 3"th P.C.C. (1:3:6).
SUPER STRUCTURE - First class brick work in cement mortar (1:6).
SLAB,BEAM, stairs & LINTEL - All R.C.C. work (1:1.5:3).
WOOD WORK - All door & window frames of sal wood
PLASTERING - 12mm cement plaster (1:6) both side.

SCHEDULE

D1 - 1.07 X 2.13	W - 0.9 x 1.22
D2 - 0.9 X 2.13	W1 - 1.22 x 1.22
D3 - 0.76 X 2.13	W2 - 1.5 X 1.22
CG - 1.22 X 2.13	V - 0.61 x 0.61

DETAILS OF AREA

1).LAND AREA :- 220.98 SQM
 2).GROUND FLOOR AREA :- 132.46 SQM
 3). FIRST FLOOR AREA :- 132.46 SQM
 4).COVERED AREA :- 264.92 SQM
 5).% OF PLINTH AREA :- 59.94
 6).G.F.A.R :- 1.2

TITLE OF DRAWING

Proposed residential building plan of 1.) RAJESH KUMAR BELDAR, 2.) KUNDAN BELDAR BOTH S/O KISHOR BELDAR OF PATRAKULHI, DHANBAD ON MOUZA - PATRAKULHI NO. 46, OLD KHATA NO. - 40, NEW KHATA NO. - 24, OLD PLOT NO. - 560, NEW PLOT NO. 1036 IN THE DISTRICT OF DHANBAD, JHARKHAND

SIG. OF OWNER

SIG. OF ENGINEER

AREA STATEMENT DHANBAD MUNICIPAL CORPORATION	VERSION NO. 1.0.32
PROJECT DETAILS	VERSION DATE: 16/10/2020
Project No. :-	Plot Use :- Residential
Region :- RESIDENTIAL/URBAN LOCAL BODIES	Plot Location :- Residential/Urban Local Bodies
District :- DHANBAD	Land Use Zone :- RA
Application Type :- General Proposal	Abutting Road Width :-
Project Type :- Development	Plot No. :-
Nature of Development :- New	Revenue Survey No./Survey No. :-
Location :- Old Area	Trans No. :-
Sub Location :- RA	History No. :-
Wing/Muza Name :-	Khata No. :-
Work No. :-	North :-
Road/Sheet :-	South :-
	East :-
	West :-

AREA DETAILS	sq. mt.
AREA OF PLOT (Minimum)	215.24
Net Plot Area (Gross Plot Area - Deduction from Gross Plot Area)	215.24
Deductions for Balance Plot Area from Gross Plot Area	
COF Area	31.49
Total	31.49
Balance Plot Area (Net Plot Area - Recreational/Amenity Area)	183.75
Plot Area for Coverage (Net Plot Area)	215.24
Plot Area for FSI (Net Plot Area - Recreational/Amenity Area)	215.24

COVERAGE CHECK	
Proposed Coverage Area (1:1.5:3)	132.46
Total Coverage Area (1:1.5:3)	132.46
FAR CHECK	
Proposed FAR	1.2
Total FAR	1.2
BUILT UP AREA CHECK	
Total Proposed Built Up Area	264.92
ARCHT (ENGRS) /SUPERVISOR (Regd)	OWNER

DEVELOPMENT AUTHORITY	LOCAL BODY
-----------------------	------------

Color Index	
ABUTTING ROAD	Black
PROPOSED WORK (COVERAGE AREA)	Green
EXISTING (To be retained)	Blue
EXISTING (To be demolished)	Red

MARGIN DETAIL:					
Building	Plot Name	Front Margin	Rear Margin	Side Margin	Sidew Margin
A1 (A1)	1.036/2020	3.58	4.47	1.09	0.68

FAR & Tenement Details (Table 4c-1)					
Building	No. of Same Bldg	Total Built Up Area (Sq.Mt)	Proposed FAR Area (Sq.Mt)	Total FAR Area (Sq.Mt)	Tent (No.)
A1 (A1)	1	264.92	264.92	264.92	01
Grand Total	1	264.92	264.92	264.92	01

Building :A1 (A1)				
Floor Name	Total Built Up Area (Sq.Mt)	Proposed FAR Area (Sq.Mt)	Total FAR Area (Sq.Mt)	Tent (No.)
Ground Floor	132.46	132.46	132.46	01
First Floor	132.46	132.46	132.46	01
Terrace Floor	0.00	0.00	0.00	00
Total	264.92	264.92	264.92	02
Total Number of Same Buildings	1			
Total	264.92	264.92	264.92	02

SCHEDULE OF JOINERY				
BUILDING NAME	NAME	LENGTH	HEIGHT	NO. OF
A1 (A1)	D	0.75	2.10	06
A1 (A1)	D	0.91	2.10	02
A1 (A1)	D	0.94	2.10	03
A1 (A1)	D	1.07	2.10	12
Total	-	-	-	23

SCHEDULE OF JOINERY				
BUILDING NAME	NAME	LENGTH	HEIGHT	NO. OF
A1 (A1)	W	0.61	1.20	02
A1 (A1)	W	0.77	1.20	02
A1 (A1)	W	0.80	1.20	02
A1 (A1)	W	0.93	1.20	02
A1 (A1)	W	1.15	1.20	02
A1 (A1)	W	1.09	1.20	02
A1 (A1)	W	2.34	1.20	02
A1 (A1)	W	2.37	1.20	02
A1 (A1)	W	2.45	1.20	02
A1 (A1)	W	2.90	1.20	02
Total	-	-	-	25

URBIA Table for Building :A1 (A1)					
FLOOR	Name	URBIA Type	URBIA Area	Cover Area	No. of Tenants
GROUND FLOOR	SPLIT 1	FLAT	218.60	218.61	11
Total	-	-	218.60	218.61	11