

SITE PLAN

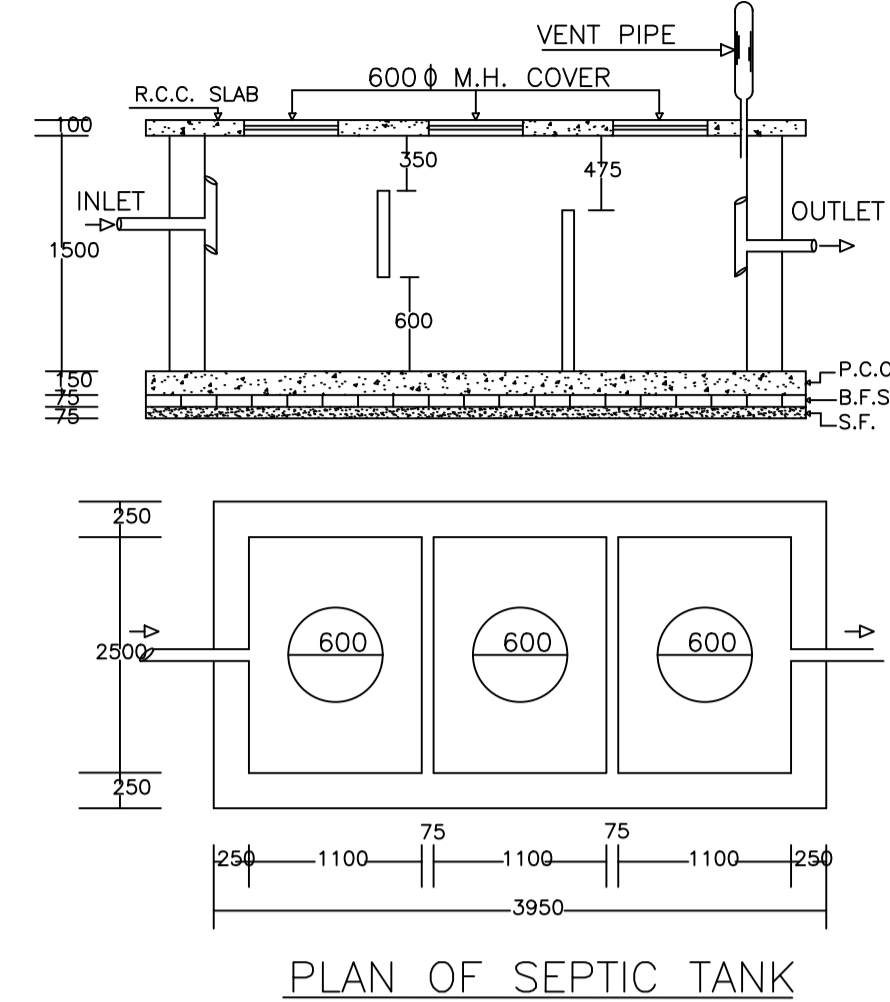

PLAN OF SEPTIC TANK

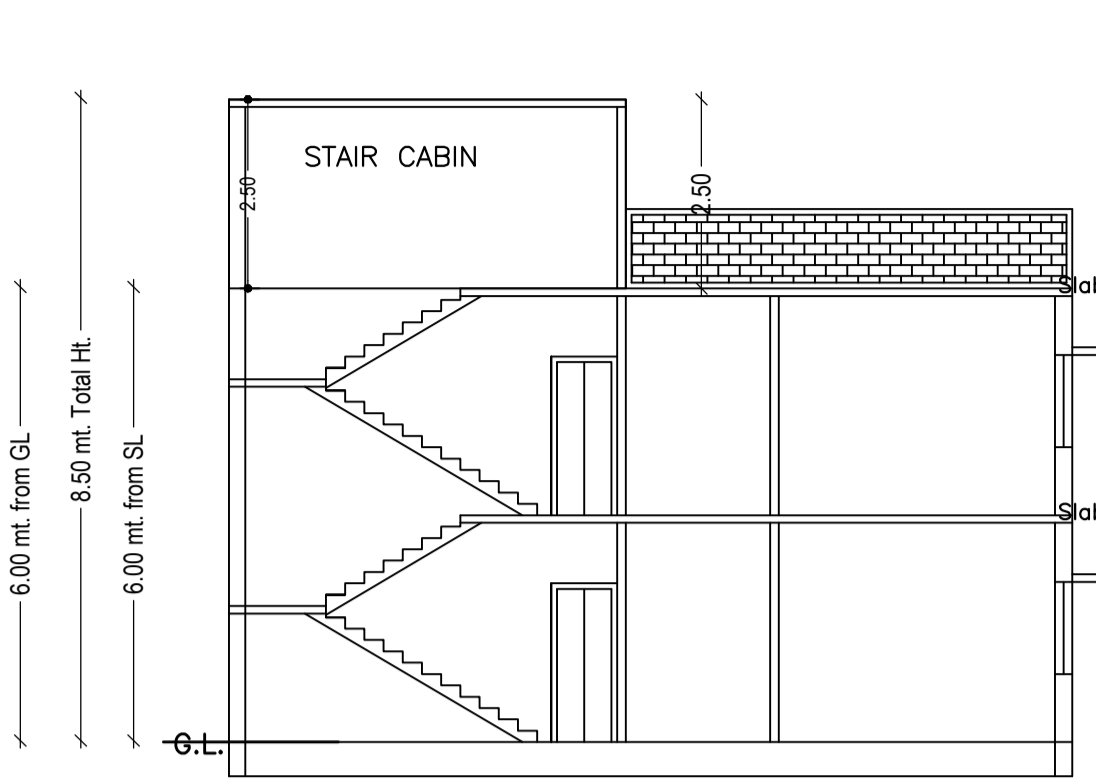

SECTION ON X-X

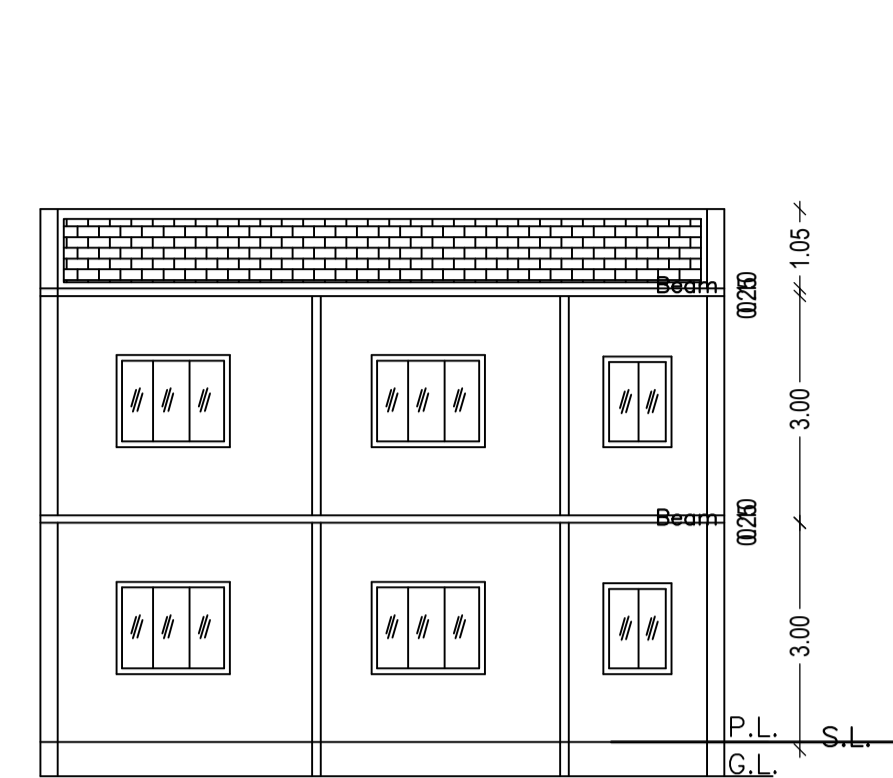

SECTION ON Y-Y

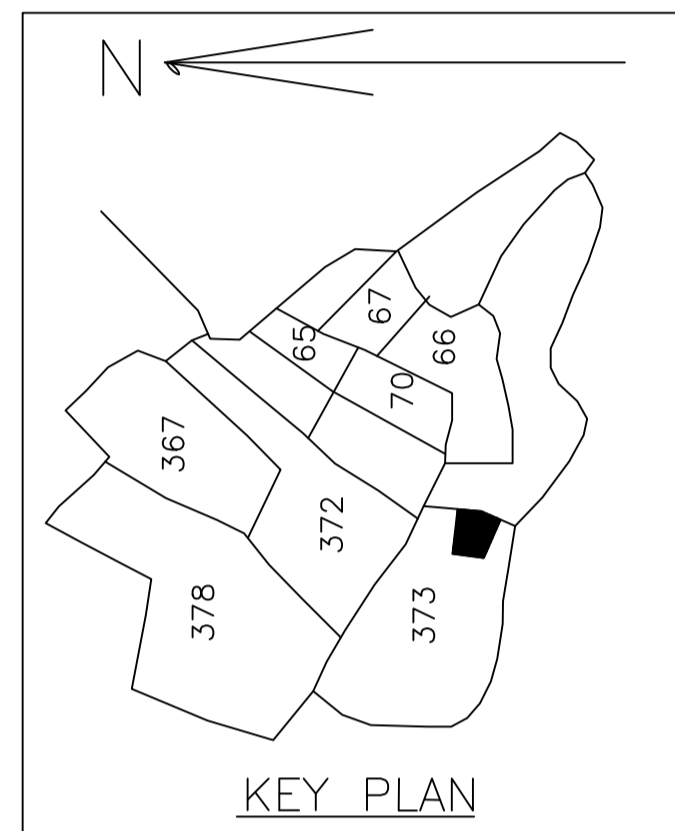

KEY PLAN

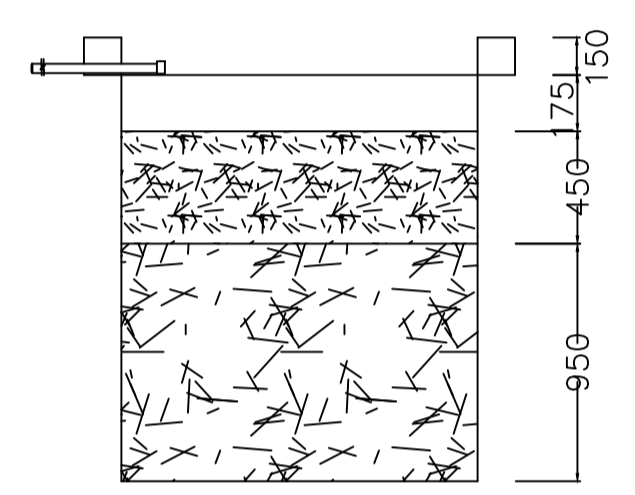

SECTION AT Y-Y

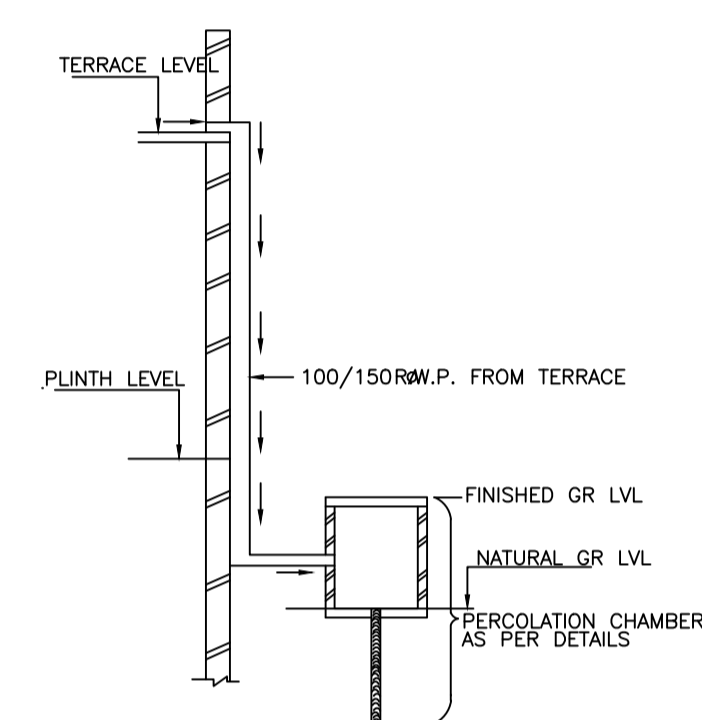

ROOF TOP RAIN WATER COLLECTION SYSTEM

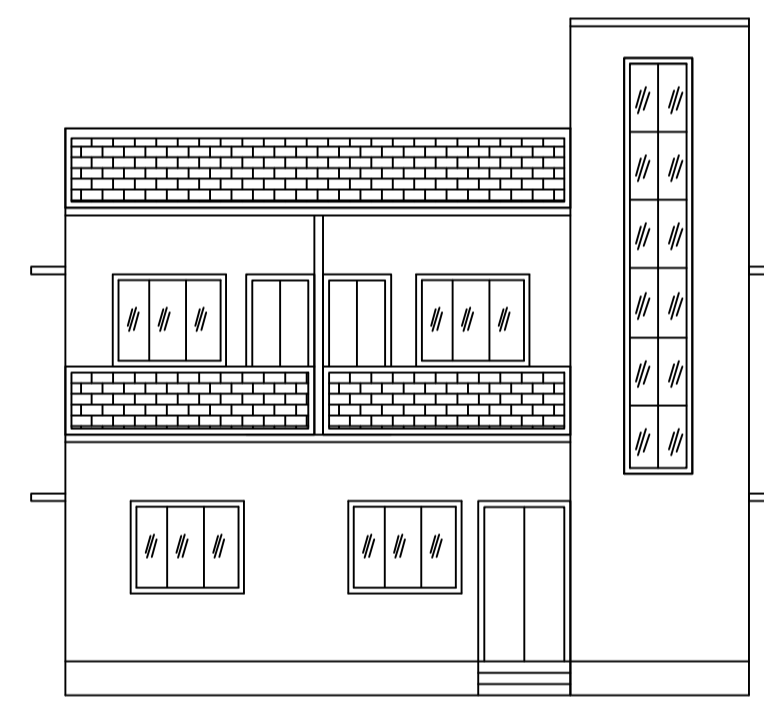

FRONT ELEVATION

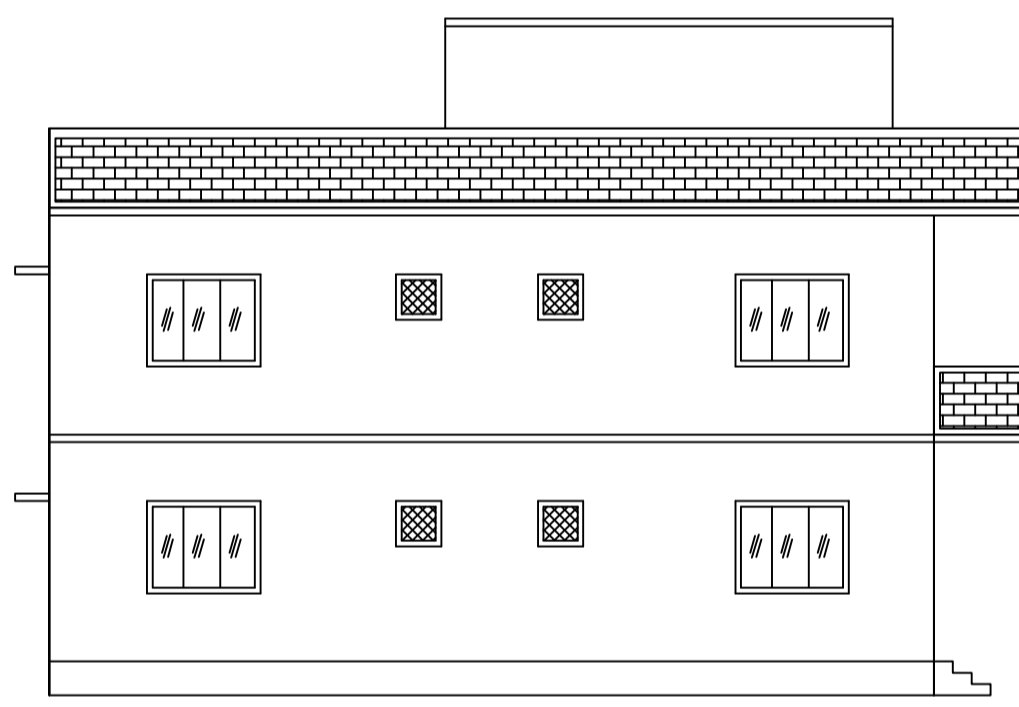

LEFT SIDE ELEVATION

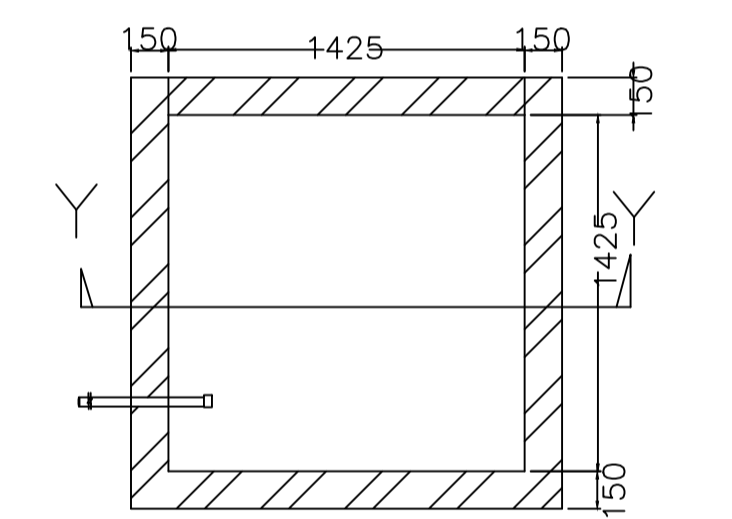

PLAN OF RECHARGE WELL WATER HARVESTING

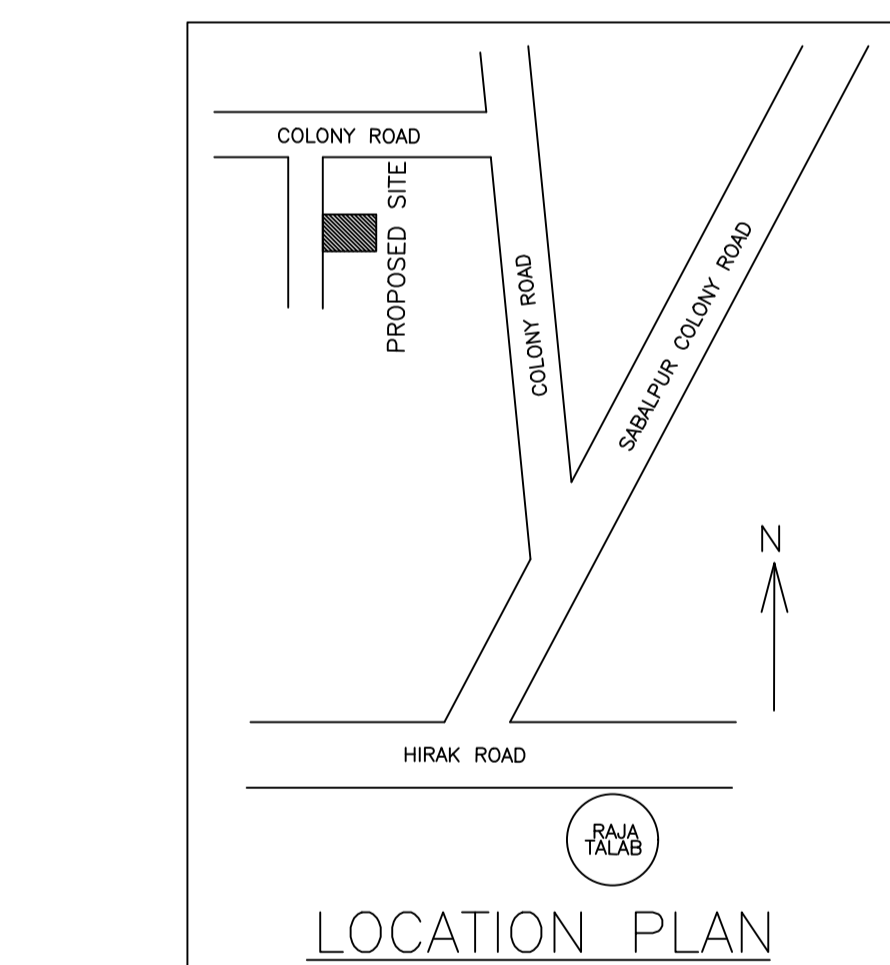

LOCATION PLAN

Building USE/SUBUSE Details

Building Name	Building Use	Building SubUse	Building Structure
AA (AA)	Residential	Residential Bldg/Apartment	Non-Highrise

SCHEDULE OF DOOR:

BUILDING NAME	NAME	LENGTH	HEIGHT	NOS
AA (AA)	D3	0.76	2.10	04
AA (AA)	D2	0.90	2.10	02
AA (AA)	D1	0.90	2.10	02
AA (AA)	D1	1.05	2.10	02
AA (AA)	D1	1.07	2.10	07
AA (AA)	D	1.22	2.10	01
AA (AA)	D	1.37	2.10	01

SCHEDULE OF WINDOW/VENTILATION:

BUILDING NAME	NAME	LENGTH	HEIGHT	NOS
AA (AA)	V	0.61	1.20	04
AA (AA)	W1	0.91	1.20	06
AA (AA)	W	1.52	1.20	12
AA (AA)	W1	1.59	1.20	02

UnitBUA Table for Building :AA (AA)

FLOOR	Name	UnitBUA Type	UnitBUA Area	Carpet Area	No. of Rooms	No. of Tenement
GROUND FLOOR PLAN	SPLIT AA	FLAT	217.25	217.12	8	1
FIRST FLOOR PLAN	SPLIT AA	FLAT	0.00	0.00	0	0
Total:			217.25	217.12	18	1

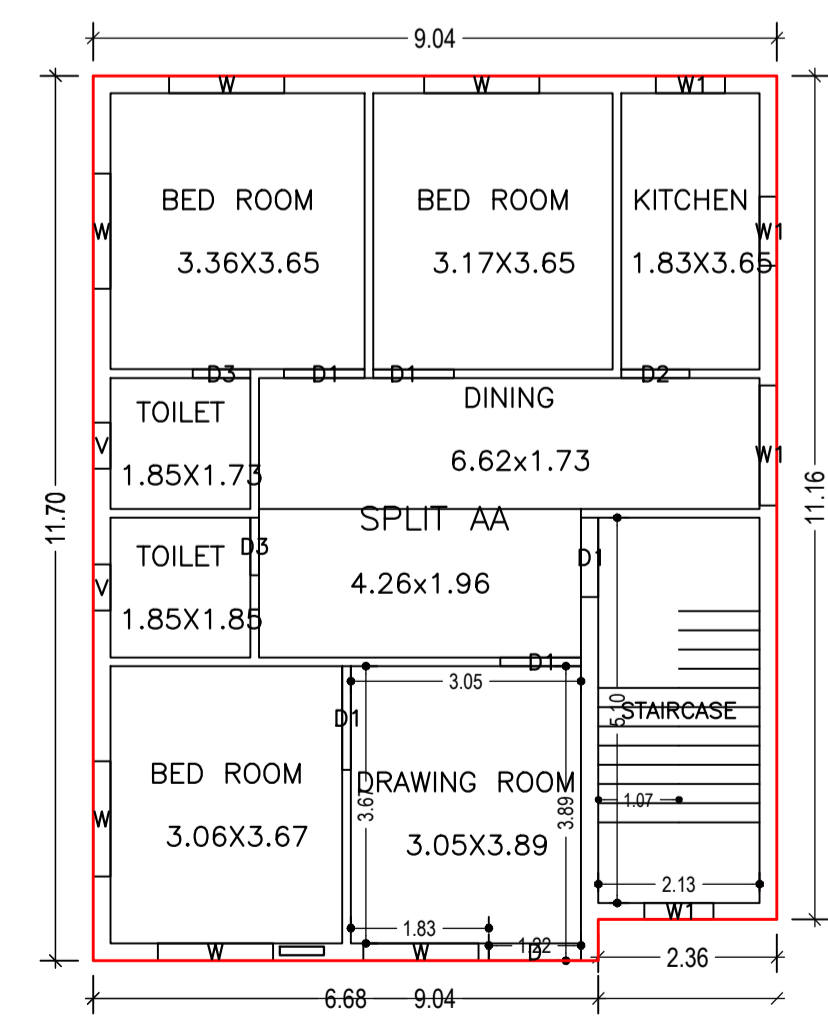

GROUND FLOOR PLAN (Proposed) (SCALE 1:100)

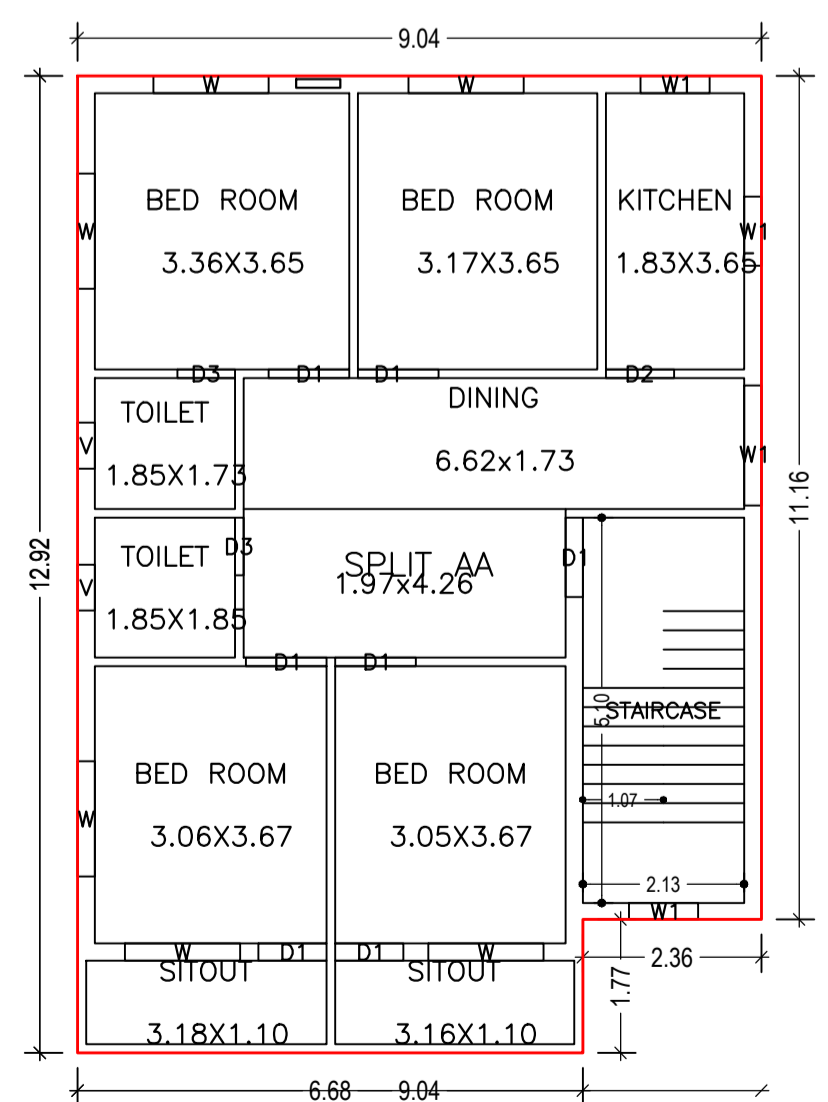

FIRST FLOOR PLAN (Proposed) (SCALE 1:100)

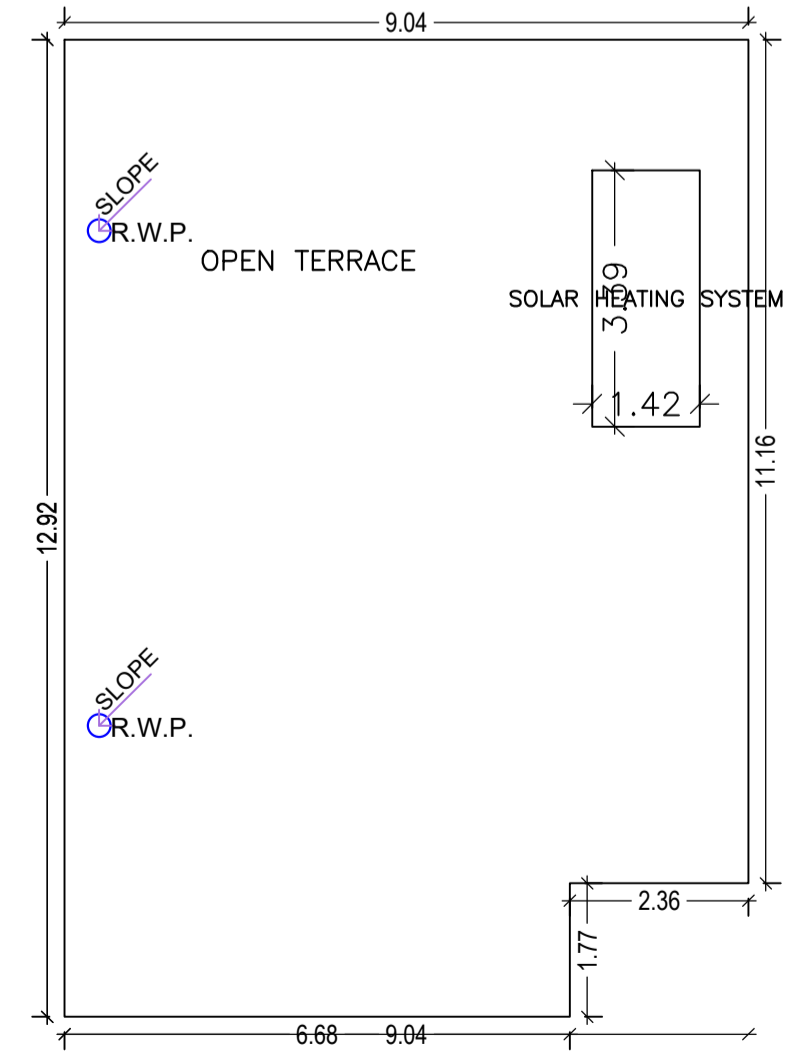

TERRACE FLOOR PLAN (SCALE 1:100)

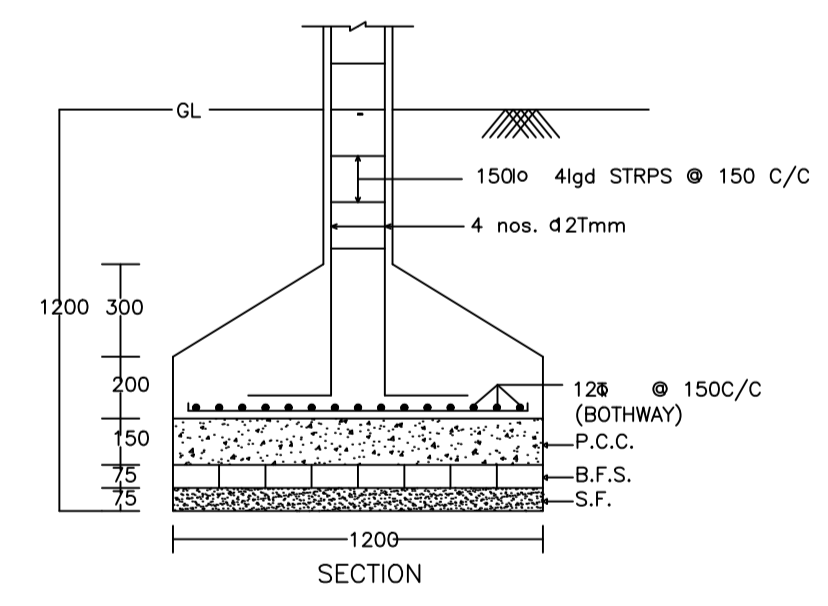

DETAIL OF COLUMNS

Proposal Basic Information

Proposal File No.	DMC/BP/0042/W23/2022
Owner Name	SMT. SASA DEVI
Khata No	12(OLD), 42(NEW)
Plot No	499(OLD), 373(NEW)
Village Name	Sabalpur
Use	Residential
SubUse	Bungalow/ Dwelling / Non Apartment

AREA STATEMENT

AREA DETAILS:	Area	SQ.MT.
AREA OF PLOT (Minimum)	(A)	195.39
NET AREA OF PLOT(Gross Plot Area - Deduction from Gross Plot area)	(A-Deductions)	195.39
Deduction for Balance Plot Area(from Gross Plot Area)		
Common Plot		21.04
Total		21.04
BALANCE AREA OF PLOT(Net Plot Area - Recreational/Amenity space)	(A-Deductions)	174.35
PLOT AREA FOR COVERAGE(Net Plot Area)	(A-Deductions)	195.39
Plot Area for FAR (Net Plot Area + Road Widening Area)	(A-Deductions)	195.39
COVERAGE CHECK		
Permissible Coverage area ( 70.00 % )		136.77
Proposed Coverage Area ( 53.51 % )		104.55
Total Prop. Coverage Area ( 53.51 % )		104.55
Balance coverage area ( 16.49 % )		32.22
FAR CHECK		
Perm. FAR Area ( 1.80 )		351.70
Total Perm. FAR area		351.70
Residential FAR		217.25
Proposed FAR Area		217.25
Total Proposed FAR Area		217.25
Consumed FAR (Factor)		1.11
Balance FAR Area		134.45
BUILT UP AREA CHECK		
Total Proposed BuiltUp Area		217.25
ARCHITECT (Regd)		AMRESH KUMAR BHARTI
ENGINEER (Regd)		
SUPERVISOR (Regd)		
OWNER (Regd)		SMT. SASA DEVI
DEVELOPMENT AUTHORITY		LOCAL BODY

COLOR INDEX

PLOT BOUNDARY	Black
ABUTTING ROAD	Red
PROPOSED CONSTRUCTION	Green
COMMON PLOT	Yellow
ROAD WIDENING AREA	Blue
EXISTING (To be retained)	Orange
EXISTING (To be demolished)	Purple

Buildingwise Floor FAR Details

Floor Name	Building Name		Total	
	Proposed Built Up Area (Sq.mt.)	Proposed FAR Area (Sq.mt.)	Total Proposed Built Up Area (Sq.mt.)	Total FAR Area (Sq.mt.)
Ground Floor	104.55	104.55	104.55	104.55
First Floor	112.70	112.70	112.70	112.70
Terrace Floor	0.00	0.00	0.00	0.00
Total:	217.25	217.25	217.25	217.25

FAR & Tenement Details (Table 4c-1)

Building	No. of Same Bldg	Total Built Up Area (Sq.mt.)	Proposed FAR Area (Sq.mt.)	Total FAR Area (Sq.mt.)	Total Consumed Additional FAR Area (Sq.mt.)	Tnmt (No.)
AA (AA)	1	217.25	217.25	217.25	217.25	01
Grand Total:	1	217.25	217.25	217.25	217.25	01

Building :AA (AA)

Floor Name	Total Built Up Area (Sq.mt.)	Proposed FAR Area (Sq.mt.)	Total FAR Area (Sq.mt.)	Total Consumed Additional FAR Area (Sq.mt.)	Tnmt (No.)
Ground Floor	104.55	104.55	104.55	104.55	01
First Floor	112.70	112.70	112.70	112.70	00
Terrace Floor	0.00	0.00	0.00	0.00	00
Total:	217.25	217.25	217.25	217.25	01
Total Number of Same Buildings:	1				
Total:	217.25	217.25	217.25	217.25	01

LTP NAME AND SIGNATURE	STRUCTURAL ENG'S NAME AND SIGNATURE	BUILDER NAME AND SIGNATURE	DIGITAL SIGNATURE
AMRESH KUMAR BHARTI DMC/ENG/0022/2016			