

Project Title : 1. JAMEELA PARWEEN 2. MD. PERWEZ ALAM

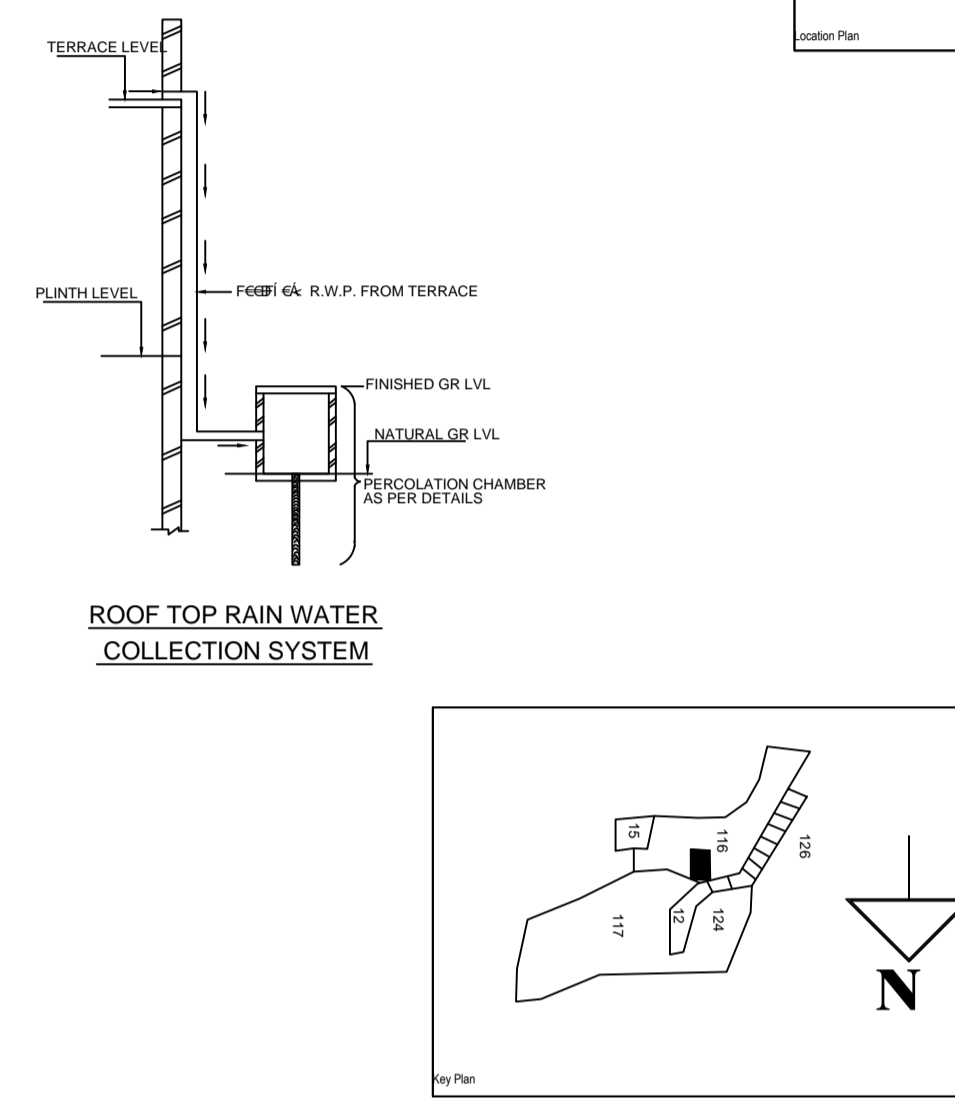
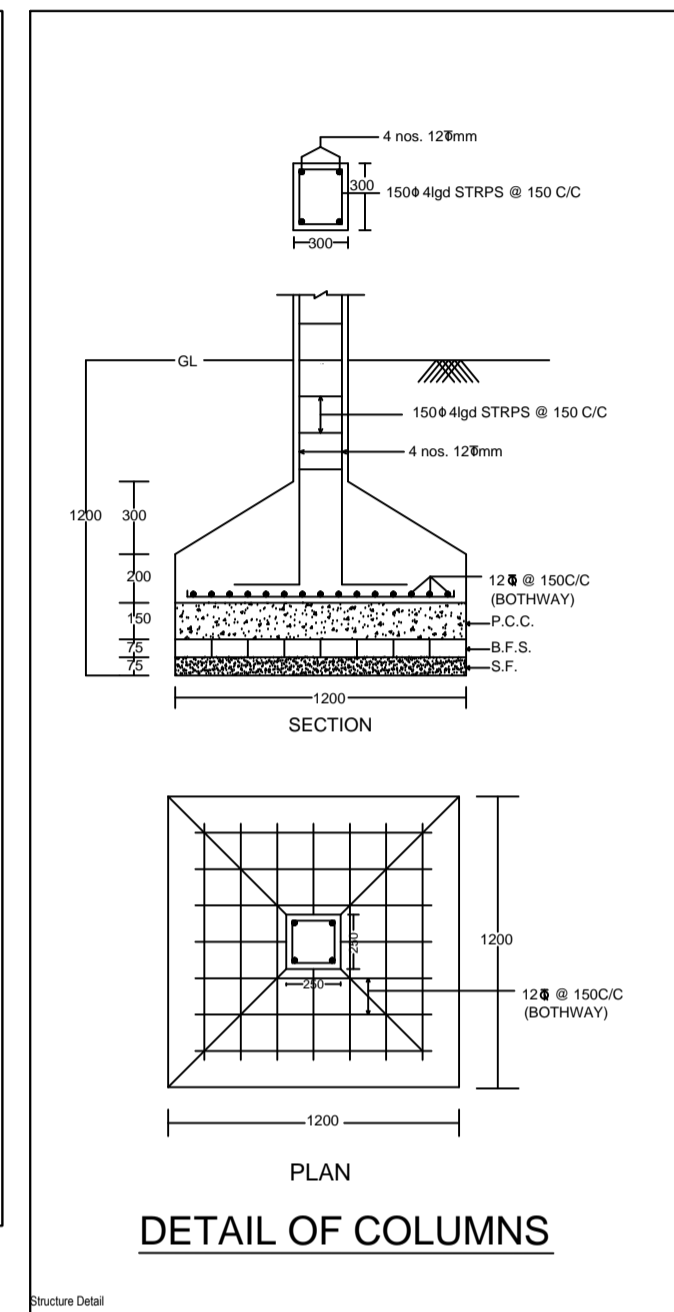
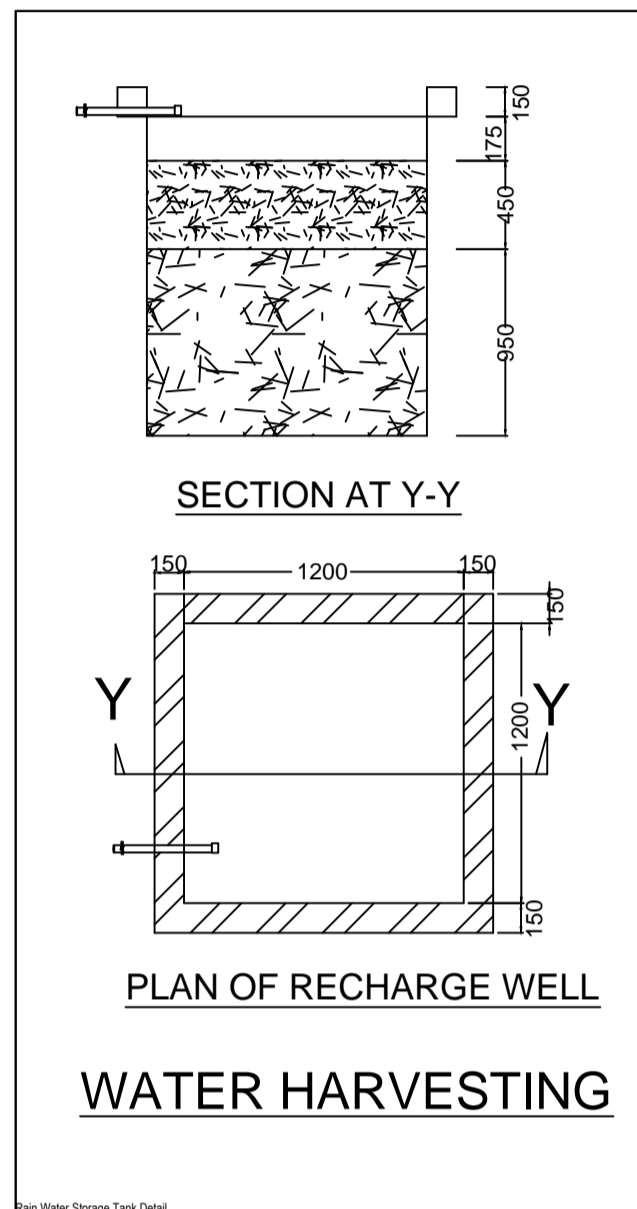
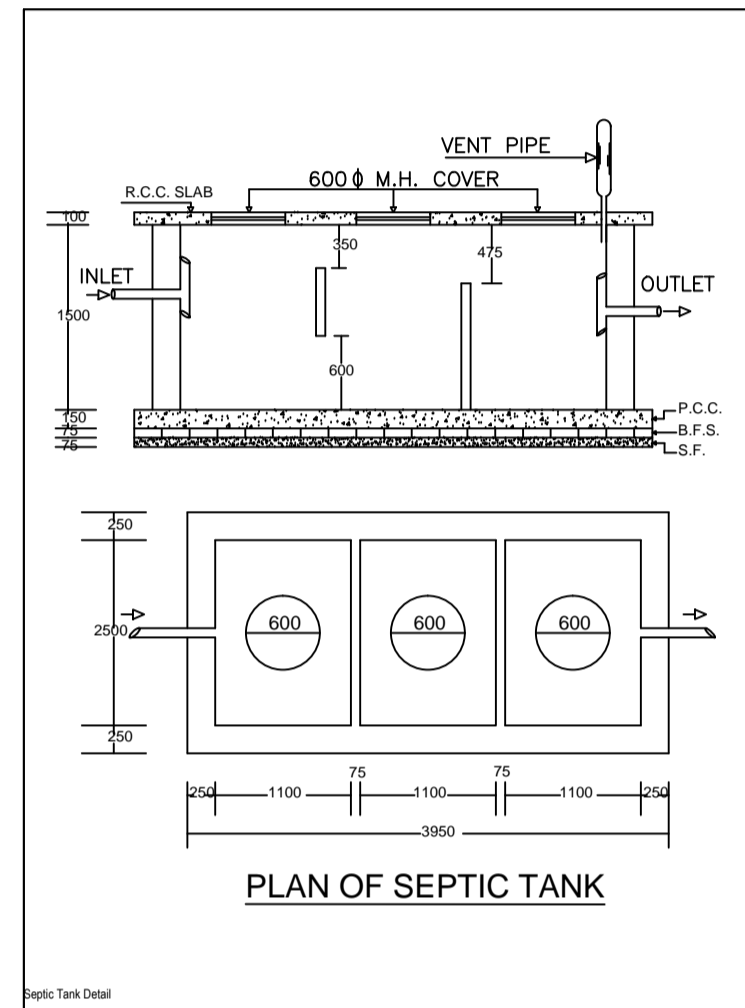
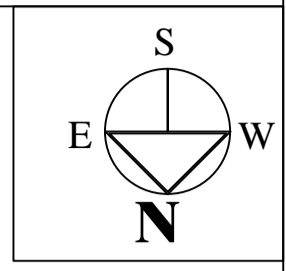
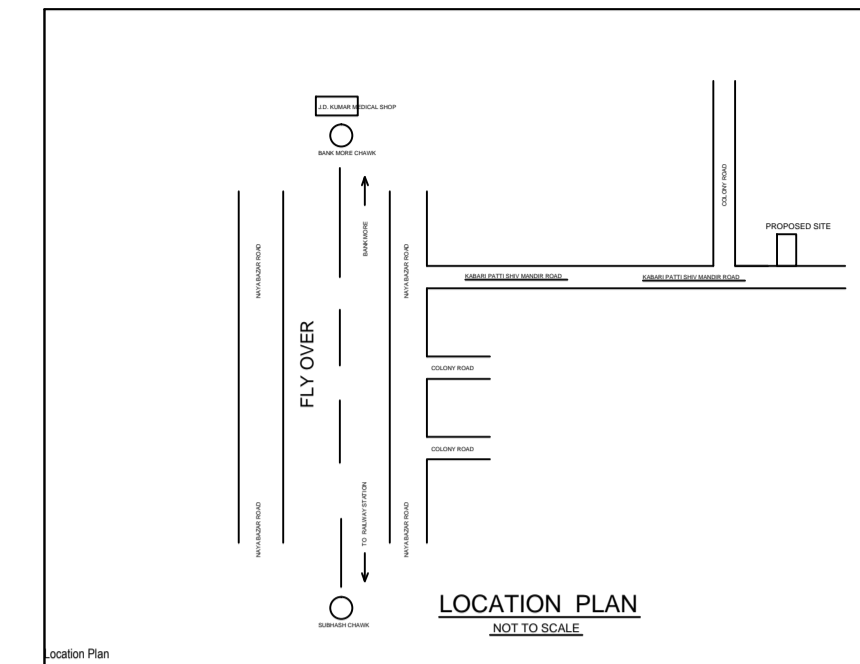
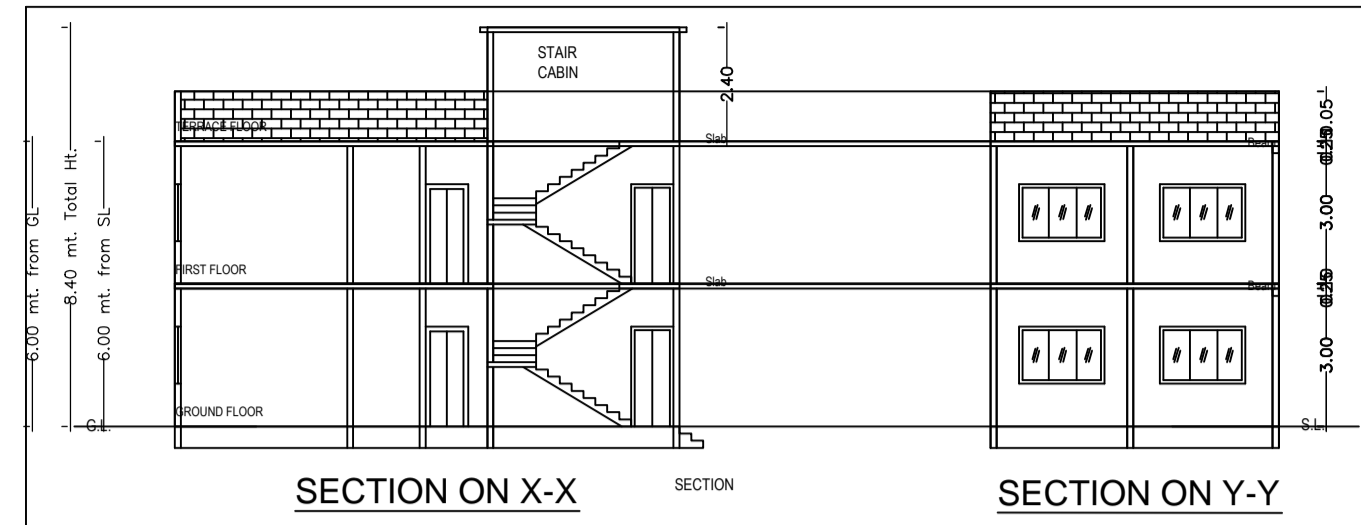
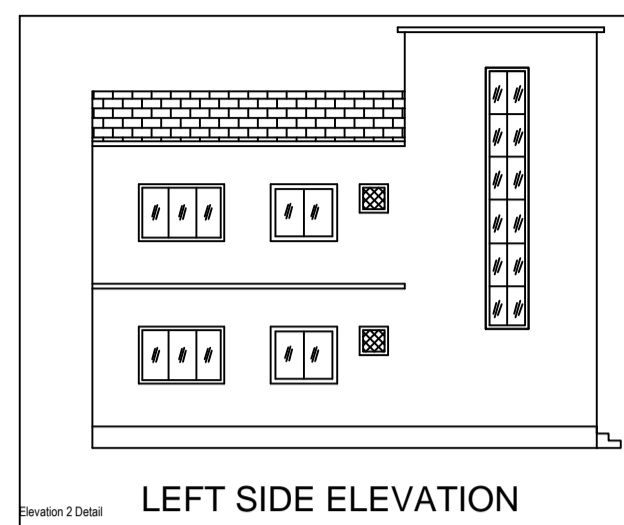
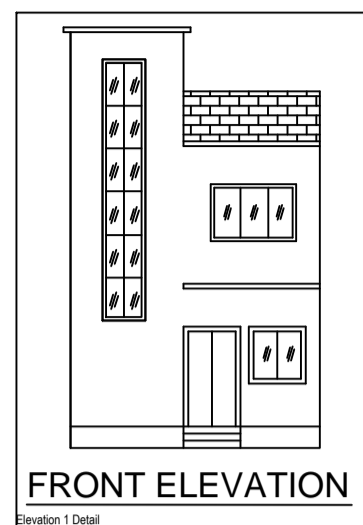

**BRIEF SPECIFICATION**  
 FOUNDATION-----CEMENT CONCRETE (1:1.5:3)  
 BRICK WORK IN FOUNDATION & SUPERSTRUCTURE  
 FIRST CLASS BRICK WORK IN CEMENT MORTAR (1:6)  
 D.P.C.-----25 D.P.C. IN CEMENT CONCRETE (1:2:4)  
 FLOOR-----25 I.P.S. OVER 75 P.C.C.  
 ROOF-----100 THK. R.C.C. ROOF (1:1.5:3)  
 LINTEL-----150 THK. R.C.C. LINTEL (1:1.5:3)  
 STAIRS-----RISE-- 150, TREAD-- 250

**DETAILS OF AREA**

TOTAL AREA (AS PER DEED)	94.33 SQM.
TOTAL AREA (AS PER SITE)	93.30 SQM.
GROUND FLOOR AREA	59.43 SQM.
FIRST FLOOR AREA	59.43 SQM.
TOTAL COVERED AREA	118.86 SQM.
% PLINTH AREA	63.70 %
FAR	1.27

**SCHEDULE**

D = 1.200X2.100	W = 1.800X1.200
D1 = 1.050X2.100	W2 = 2.400X1.200
D2 = 0.900X2.100	V = 0.600X0.600

AREA STATEMENT (DHARBAD MUNICIPAL CORPORATION)	VERSION NO. 1.0.02
PROJECT DETAIL	VERSION DATE: 16/10/2020
Plot No. Residential	
Project: DHARBAD	Plot Location: Buriguda (Dwelling / Non-Residential)
Application Type: General Proposal	Land Use Zone: Residential
Project Type: Building/Extension	Adjoining Road Width: -
Nature of Development: New	Plot No.:
Location: Old Area	Thana No.:
Site Location: No.	Plotting No.:
Village/Muza Name:	Khasa No.:
West Side:	South:
North:	East:
Other:	West:

**AREA DETAILS**

AREA OF PLOT (Minimum)	(A)	93.30
Net PIG Area (Gross PIG Area - Deduction from Gross Plot area)	(A-Deductions)	93.30
Deductions for Balance PIG Area (from Gross PIG Area)		
COP Area		15.93
Total		15.93
Balance PIG Area (Net PIG Area - Recreation/Amenity space)	(A-Deductions)	77.37
Plot Area for Coverage (Net PIG Area)	(A-Deductions)	93.30
Plot Area for Foot Path (Net PIG Area - Road/Working Area)	(A-Deductions)	93.30

**COVERAGE CHECK**

Proposed Coverage Area (63.70 %)	59.43
Total Coverage Area (63.70 %)	59.43

**PARK CHECK**

Proposed Area of FAR	118.86
Legal Area of FAR	118.86

**MINUTY UP AREA CHECK**

ICR Proposed (Built Up Area)	118.86
ARCHT. ENGRG / SUPERVISOR (Regd.)	OWNER
DEVELOPMENT AUTHORITY	LOCAL BODY

**COLOR INDEX**

Plot Boundary	---
Abutting Road	---
Proposed Work (Coverage Area)	---
Existing (To be retained)	---
Existing (To be demolished)	---

**Color Index**

Building / Plot Name	Road Name	Front Margin	Rear Margin	Side1 Margin	Side2 Margin
AA (AA)	Main Road	2.04	1.51	0.90	0.00

**FAR & Terment Details (Table 4c-1)**

Building	No. of Same Bldg	Total Built Up Area (Sq.mt.)	Proposed FAR Area (Sq.mt.)	Total FAR Area (Sq.mt.)	Tract (No.)
AA (AA)	1	118.86	118.86	118.86	01
Grand Total	1	118.86	118.86	118.86	01

PRODUCED BY AN AUTODESK EDUCATIONAL PRODUCT

PRODUCED BY AN AUTODESK EDUCATIONAL PRODUCT

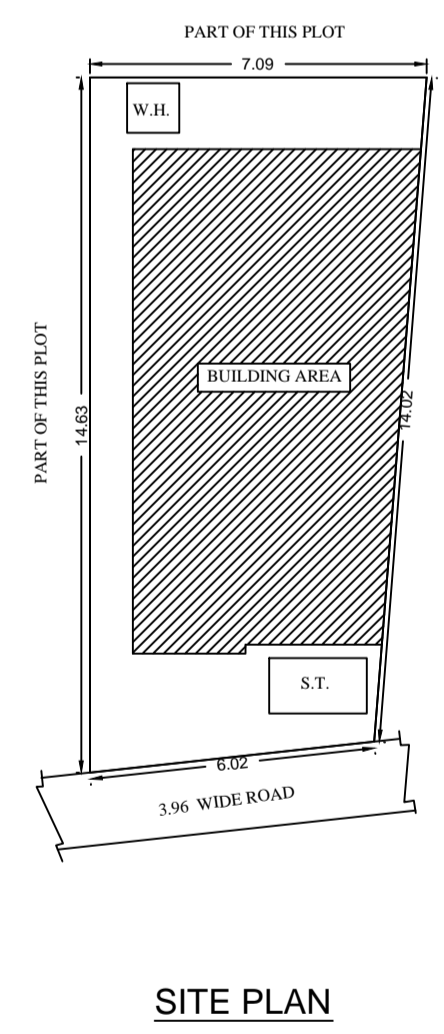
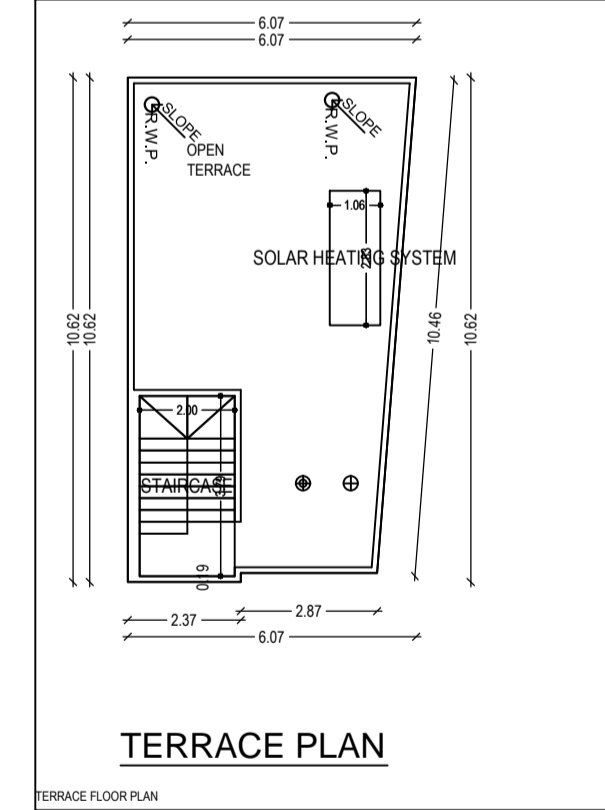
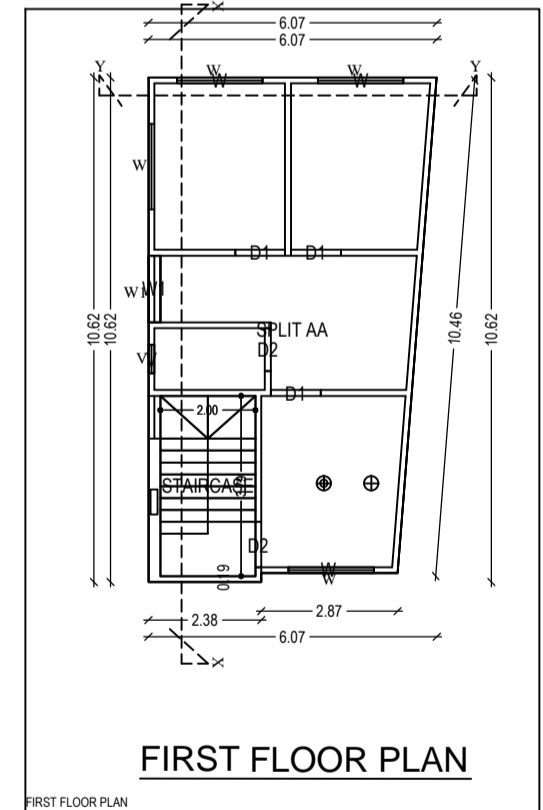
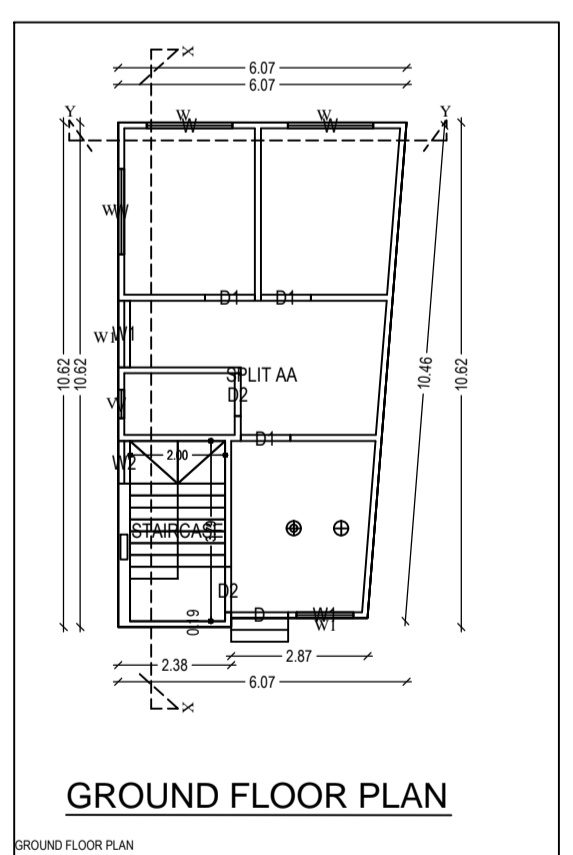
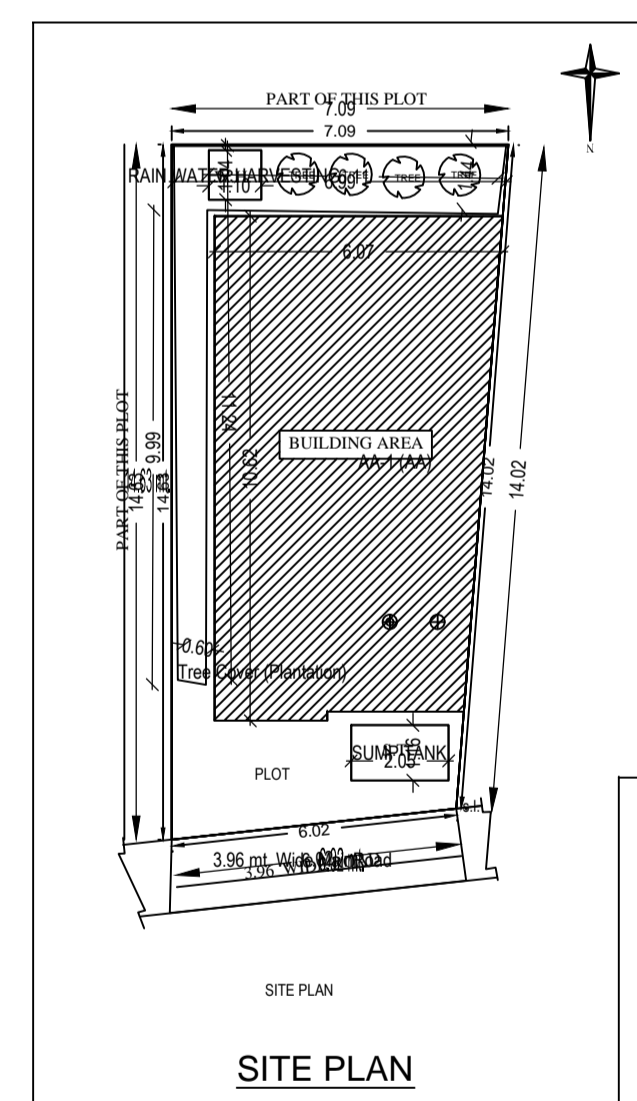

SIGNATURE OF OWNER

SIGNATURE OF ENGINEER

SCALE ALL DIMENSION ARE IN METRE

**Building 'AA' (AA)**

Floor Name	Total Built Up Area (Sq.mt.)	Proposed FAR Area (Sq.mt.)	Total FAR Area (Sq.mt.)	Tract (No.)
Ground Floor	59.43	59.43	59.43	01
First Floor	59.43	59.43	59.43	02
Terrace Floor	0.00	0.00	0.00	00
Total	118.86	118.86	118.86	01
Total Number of Same Buildings	1			
Grand Total	118.86	118.86	118.86	01

**SCHEDULE OF JOINERY:**

BUILDING NAME	NAME	LENGTH	HEIGHT	NOS
AA (AA)	D2	0.90	2.10	02
AA (AA)	D1	1.05	2.10	01
AA (AA)	D	1.20	2.10	01
Total				04

**SCHEDULE OF JOINERY:**

BUILDING NAME	NAME	LENGTH	HEIGHT	NOS
AA (AA)	V	0.60	1.00	02
AA (AA)	W2	0.90	1.20	01
AA (AA)	W1	1.20	1.20	01
AA (AA)	W	1.40	1.20	03
AA (AA)	W	1.80	1.20	02
Total				09

**Unit/BUA Table for Building 'AA' (AA)**

FLOOR	Name	Unit/BUA Type	Unit/BUA Area	Carpet Area	No. of Rooms	No. of Tenement
GROUND FLOOR PLAN	SPLIT AA	FLAT	118.86	118.70	5	1
Total			118.86	118.70	10	1