

Proposal Basic Information

Proposal File No.	DMC/BP/0052/W30/2022
Owner Name	SMT SITA DEVI
Khata No	NEW - 136 , OLD - 214
Plot No	NEW - 46 , OLD - 27
Village Name	Patrakulhi
Use	Residential
SubUse	Bungalow/ Dwelling / Non Apartment

AREA STATEMENT DHANBAD MUNICIPAL CORPORATION	VERSION NO.: 1.0.62 VERSION DATE: 16/10/2020
PROJECT DETAIL:	
Region: JHARKHAND URBAN LOCAL BODIES	Plot Use: Residential
District: DHANBAD	Plot SubUse: Bungalow/ Dwelling / Non Apartment
Authority: DHANBAD MUNICIPAL CORPORATION	PlotNearby/ReligiousStructure: NA
Inward No: DMC/BP/0052/W30/2022	Plot/SubPlot No: NEW - 46 , OLD - 27
Application Type: General Proposal	North: Plot No. - PLOT NO. 28
Project Type: Building Permission	South: Plot No. - PLOT NO. 31
Nature of Development: New	East: Road Width - 3.04M WIDE ROAD
Location of Development Area: Old Area	West: Plot No. - PLOT NO. 30
AREA DETAILS:	
AREA OF PLOT (Minimum)	(A) 195.70 SQ.MT.
Deduction for NetPlot Area	
Surrender Free of Cost	4.17
Total	4.17
NET AREA OF PLOT(Gross Plot Area - Deduction from Gross Plot area)	(A-Deductions) 191.53
Deduction for Balance Plot Area(from Gross Plot Area)	
Surrender Free of Cost	4.17
Common Plot	17.90
Total	22.07
BALANCE AREA OF PLOT(Net Plot Area - Recreational/Amenity space)	(A-Deductions) 173.63
PLOT AREA FOR COVERAGE(Net Plot Area)	(A-Deductions) 191.53
Plot Area for FAR (Net Plot Area + RoadWidening Area)	(A-Deductions) 195.70
COVERAGE CHECK	
Permissible Coverage area (70.00 %)	134.07
Proposed Coverage Area (53.78 %)	103.01
Total Prop. Coverage Area (53.78 %)	103.01
Balance coverage area (16.22 %)	31.06
FAR CHECK	
Perm. FAR Area (1.50)	293.55
Total Perm. FAR area	293.55
Residential FAR	163.61
Proposed FAR Area	163.61
Total Proposed FAR Area	163.61
Consumed FAR (Factor)	0.84
Balance FAR Area	129.94
BUILT UP AREA CHECK	
Total Proposed BuiltUp Area	206.02
ARCHITECT (Regd)	ABHISHEK KUMAR
ENGINEER (Regd)	
SUPERVISOR (Regd)	
OWNER (Regd)	SMT SITA DEVI
DEVELOPMENT AUTHORITY	LOCAL BODY

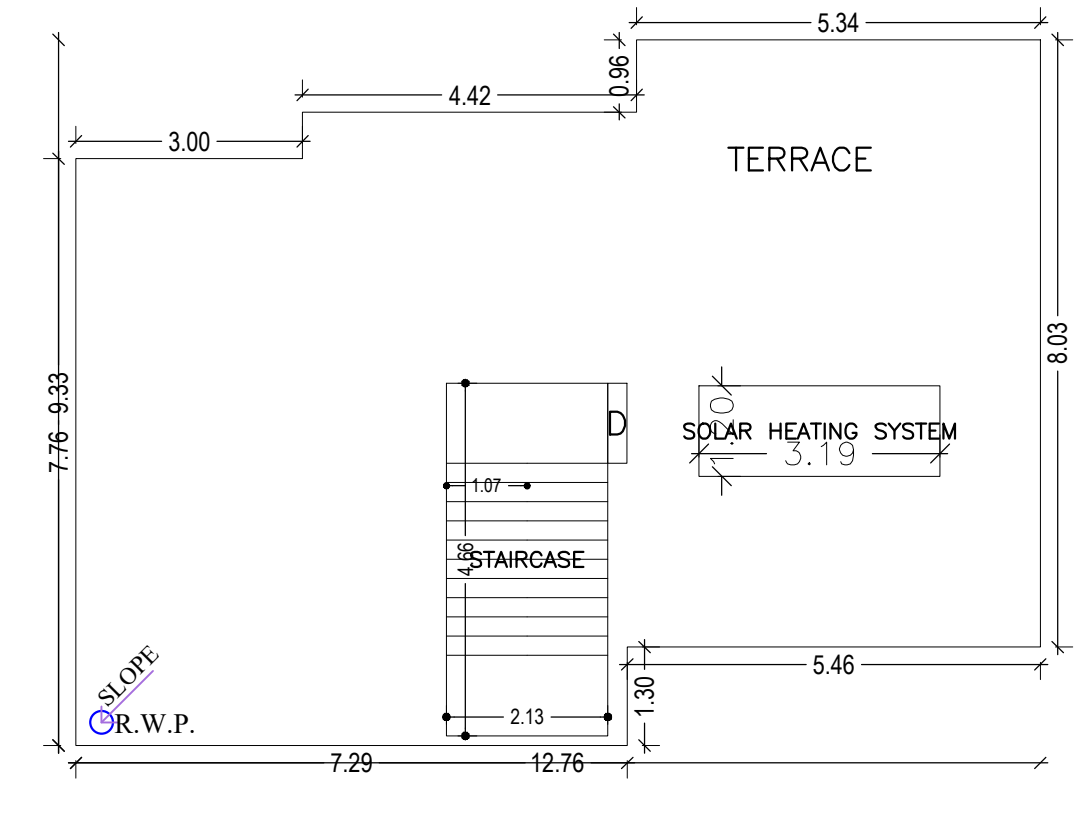
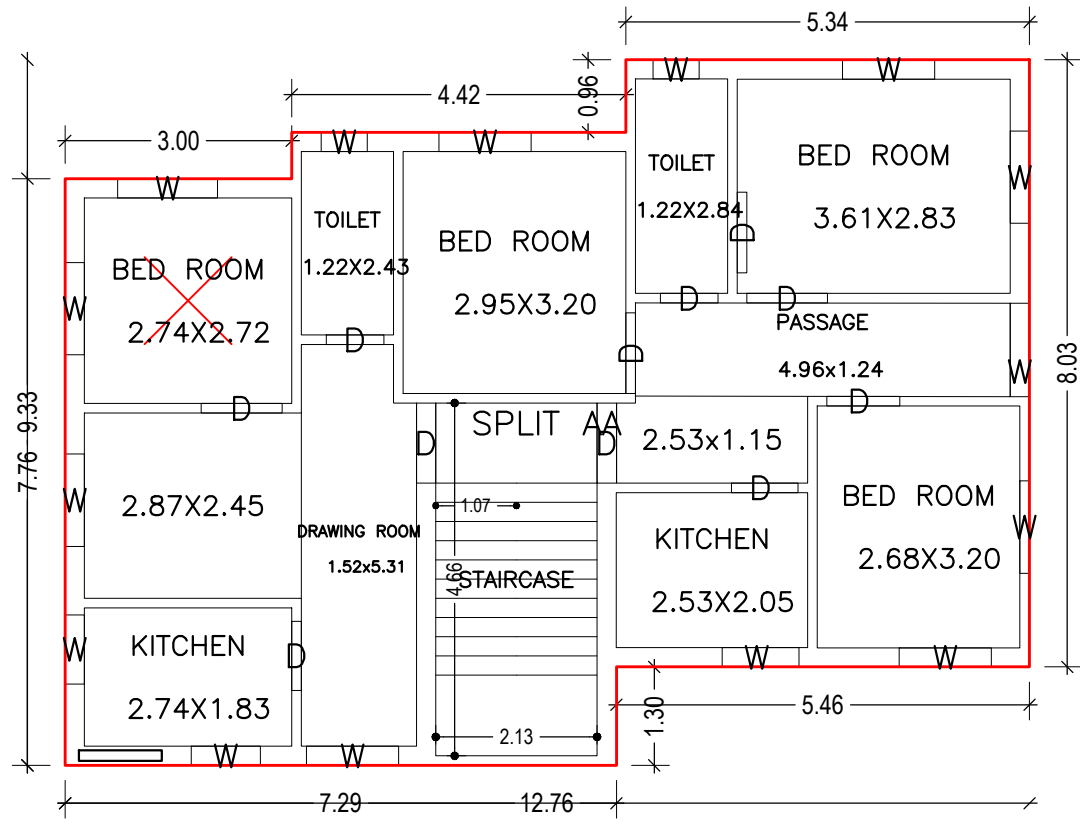
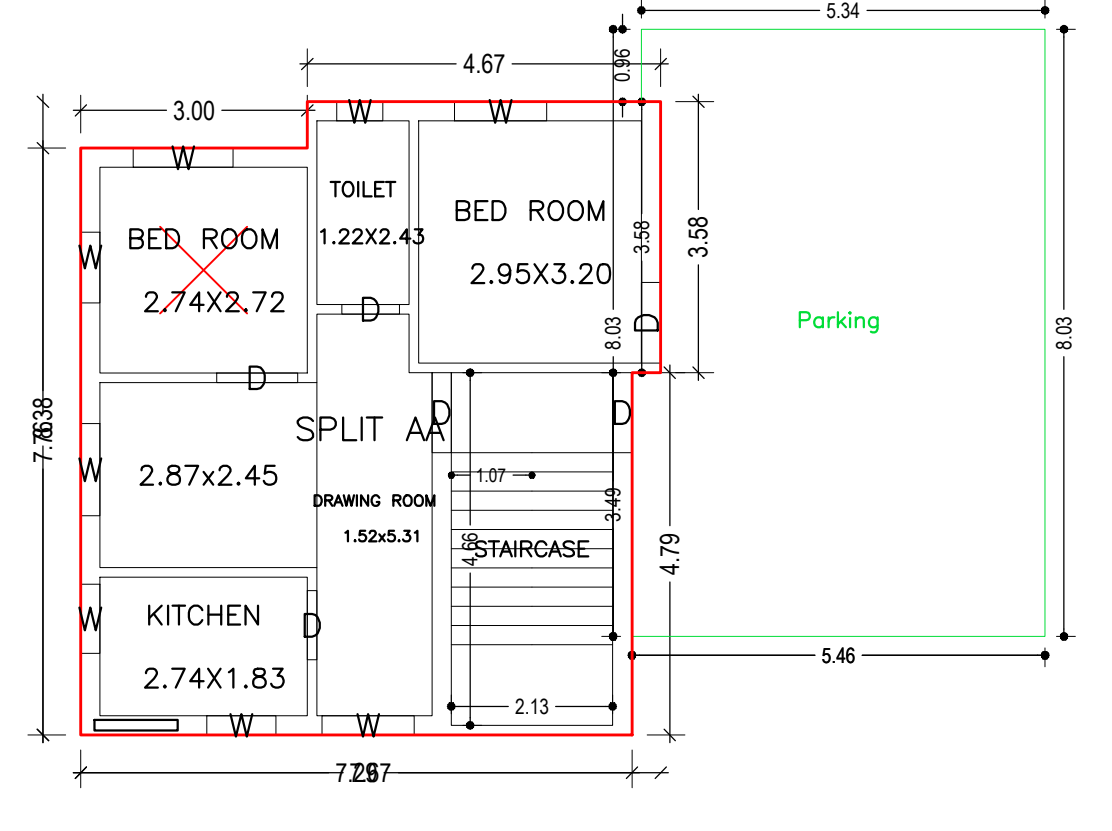
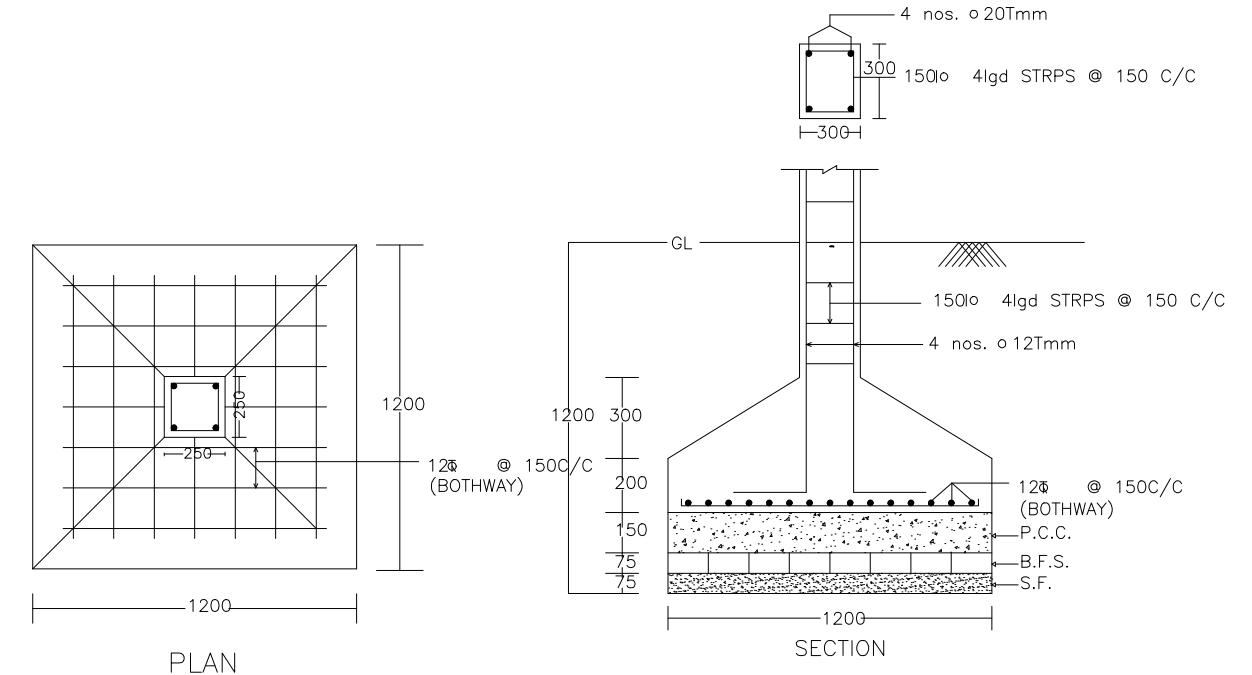

DETAIL OF COLUMNS

GROUND FLOOR PLAN (Proposed) (SCALE 1:100)

FIRST FLOOR PLAN (Proposed) (SCALE 1:100)

TERRACE FLOOR PLAN (SCALE 1:100)

COLOR INDEX

PLOT BOUNDARY	Black
ABUTTING ROAD	Red
PROPOSED CONSTRUCTION	Green
COMMON PLOT	Blue
ROAD WIDENING AREA	Yellow
EXISTING (To be retained)	Light Blue
EXISTING (To be demolished)	Light Yellow

SCHEDULE OF DOOR:

BUILDING NAME	NAME	LENGTH	HEIGHT	NOS
AA (BB)	D	0.76	2.10	03
AA (BB)	D	0.88	2.10	01
AA (BB)	D	0.91	2.10	02
AA (BB)	D	0.97	2.10	01
AA (BB)	D	1.06	2.10	03
AA (BB)	D	1.07	2.10	06

SCHEDULE OF WINDOW/VENTILATION:

BUILDING NAME	NAME	LENGTH	HEIGHT	NOS
AA (BB)	W	0.61	1.20	03
AA (BB)	W	0.91	1.20	04
AA (BB)	W	0.94	1.20	01
AA (BB)	W	1.01	1.20	01
AA (BB)	W	1.22	1.20	11
AA (BB)	W	1.23	1.20	01
AA (BB)	W	1.32	1.20	02

FAR & Tenement Details (Table 4c-1)

Building	No. of Same Bldg	Total Built Up Area (Sq.mt.)	Deductions (Area in Sq.mt.)		Proposed FAR Area (Sq.mt.)	Total FAR Area (Sq.mt.)	Total Consumed Additional FAR Area (Sq.mt.)	Tnmt (No.)
			Parking	Resi.				
AA (BB)	1	206.02	42.41	163.61	163.61	163.61	01	
Grand Total:	1	206.02	42.41	163.61	163.61	163.61	01	

Building :AA (BB)

Floor Name	Total Built Up Area (Sq.mt.)	Deductions (Area in Sq.mt.)	Proposed FAR Area (Sq.mt.)	Total FAR Area (Sq.mt.)	Total Consumed Additional FAR Area (Sq.mt.)	Tnmt (No.)
Ground Floor	103.01	42.41	60.60	60.60	60.60	01
First Floor	103.01	0.00	103.01	103.01	103.01	00
Terrace Floor	0.00	0.00	0.00	0.00	0.00	00
Total:	206.02	42.41	163.61	163.61	163.61	01
Total Number of Same Buildings :	1					
Total :	206.02	42.41	163.61	163.61	163.61	01

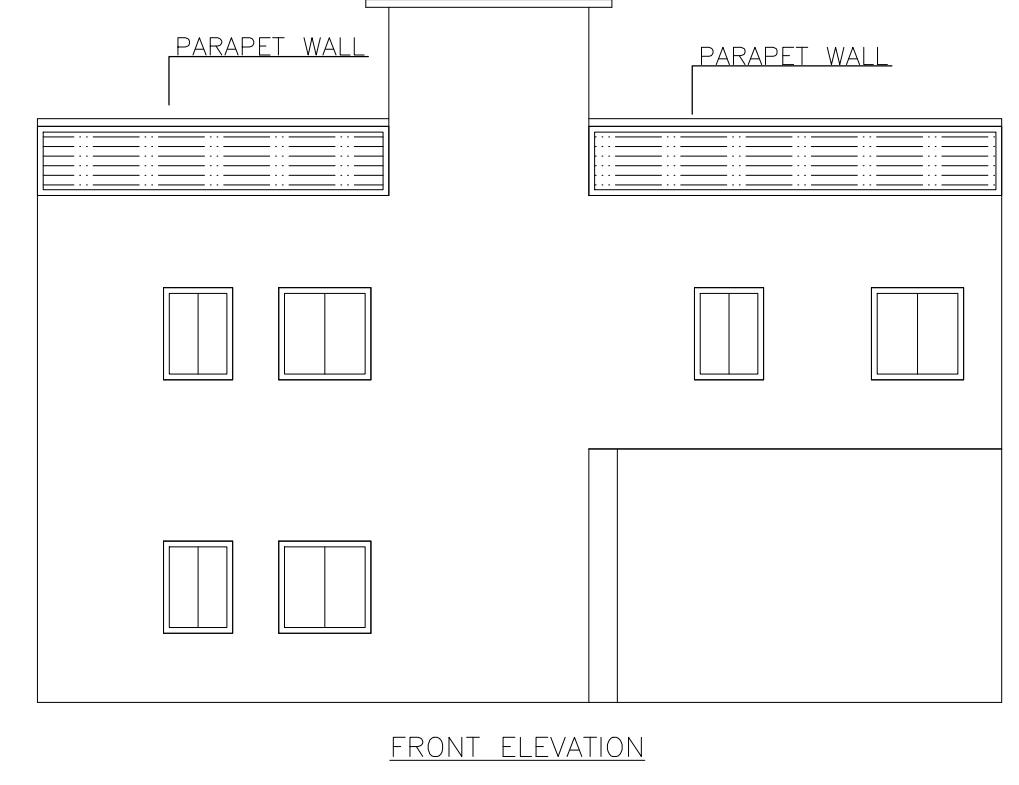
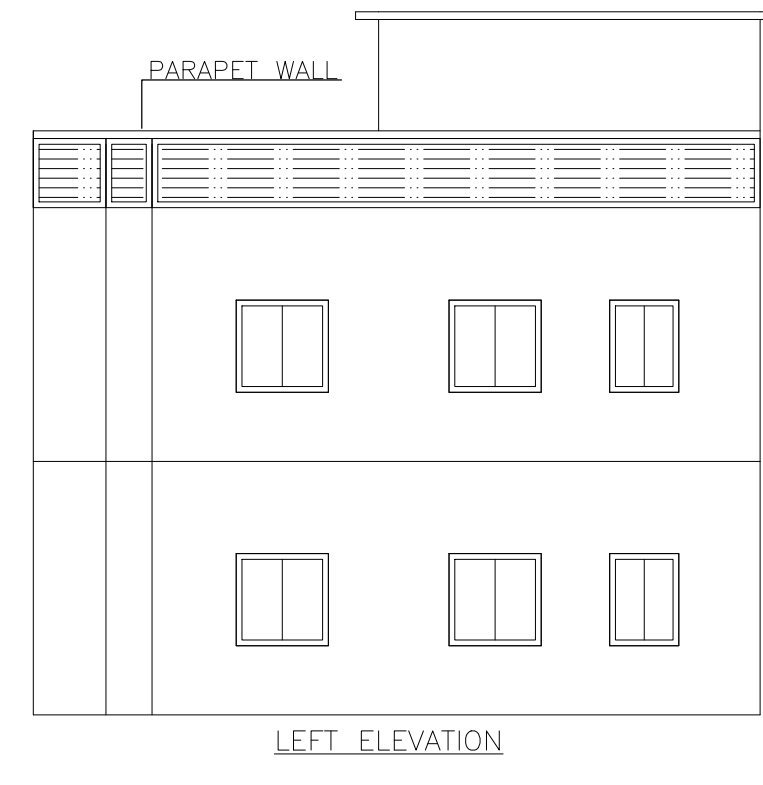

LEFT ELEVATION

FRONT ELEVATION

Buildingwise Floor FAR Details

Floor Name	Building Name AA (BB)		Total	
	Proposed Built Up Area (Sq.mt.)	Proposed FAR Area (Sq.mt.)	Total Proposed Built Up Area (Sq.mt.)	Total FAR Area (Sq.mt.)
Ground Floor	103.01	60.60	103.01	60.60
First Floor	103.01	103.01	103.01	103.01
Terrace Floor	0.00	0.00	0.00	0.00
Total:	206.02	163.61	206.02	163.61

Building USE/SUBUSE Details

Building Name	Building Use	Building SubUse	Building Structure
AA (BB)	Residential	Bungalow/ Dwelling / Non Apartment	Non-Highrise

UnitBUA Table for Building :AA (BB)

FLOOR	Name	UnitBUA Type	UnitBUA Area	Carpet Area	No. of Rooms	No. of Tenement
GROUND FLOOR PLAN	SPLIT AA	FLAT	163.61	163.30	5	1
FIRST FLOOR PLAN	SPLIT AA	FLAT	0.00	0.00	10	0
Total:	-	-	163.61	163.30	15	1

LTP NAME AND SIGNATURE	STRUCTURAL ENG'S NAME AND SIGNATURE	BUILDER NAME AND SIGNATURE	DIGITAL SIGNATURE
ABHISHEK KUMAR DMC/DFTMN/0013/2020			

Proposal Basic Information

Proposal File No.	DMC/BP/0052/W30/2022
Owner Name	SMT SITA DEVI
Khata No	NEW - 136 , OLD - 214
Plot No	NEW - 46 , OLD - 27
Village Name	Patrakulhi
Use	Residential
SubUse	Bungalow/ Dwelling / Non Apartment

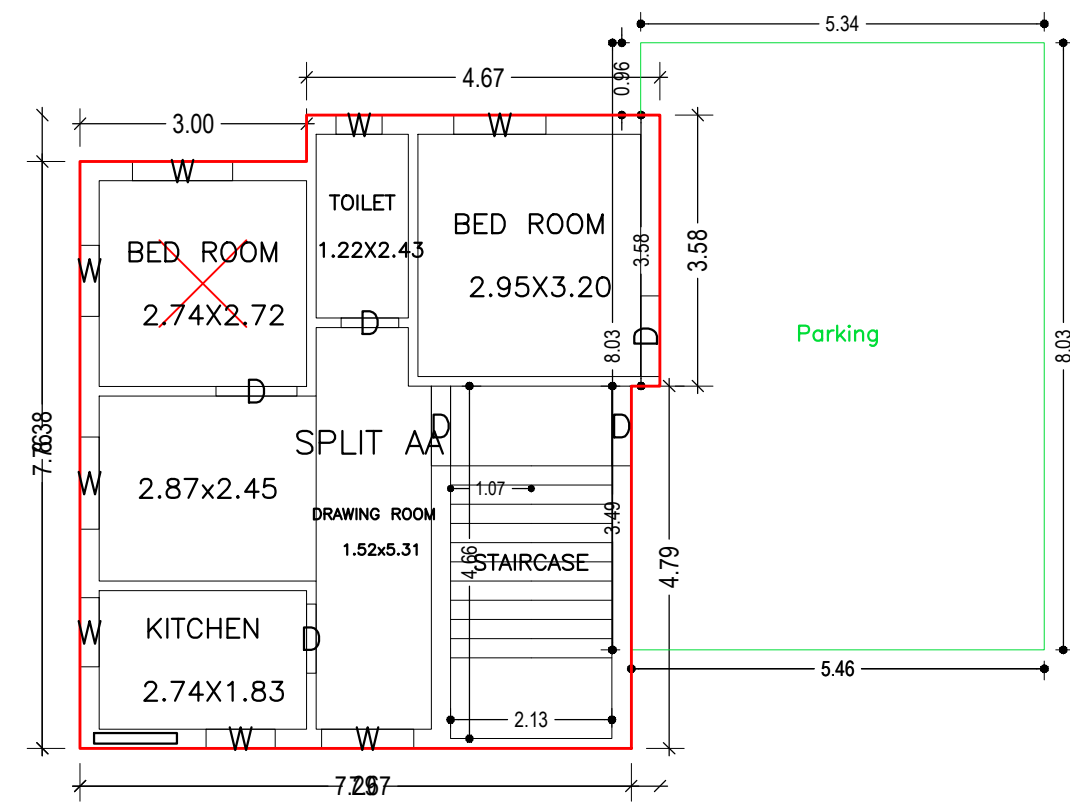

GROUND FLOOR PLAN
(Proposed)
(SCALE 1:100)

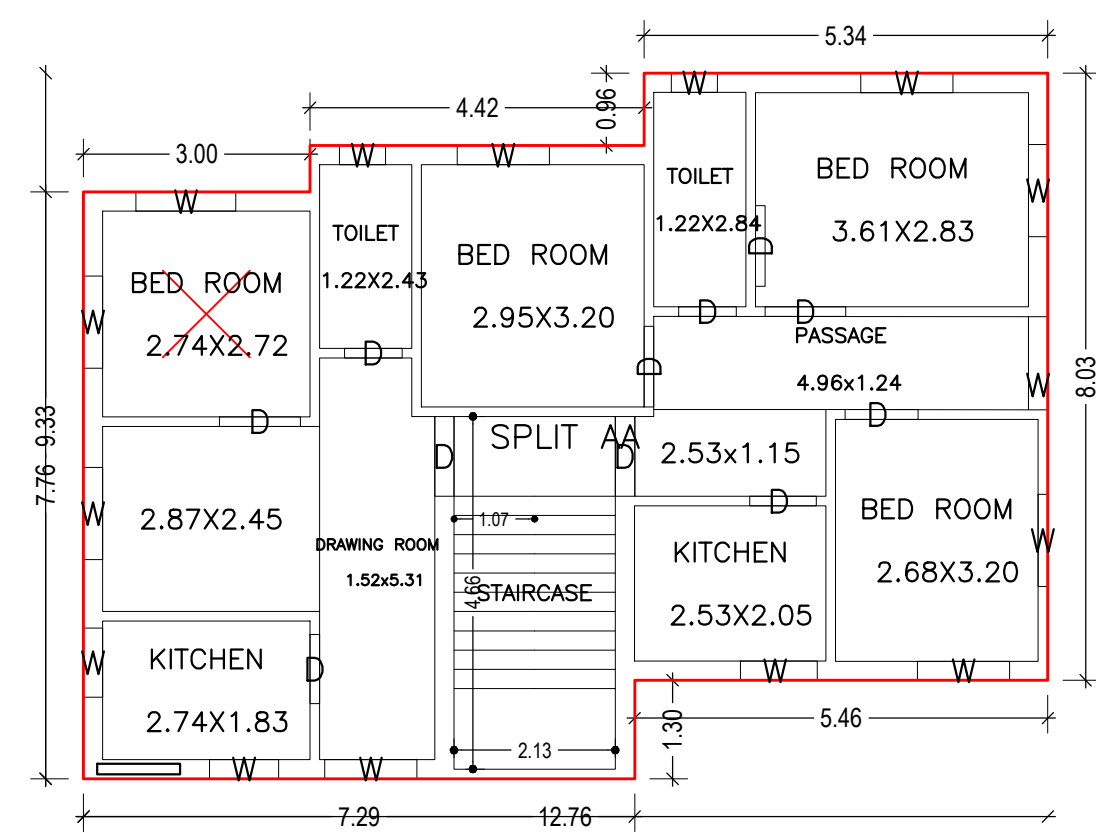

FIRST FLOOR PLAN
(Proposed)
(SCALE 1:100)

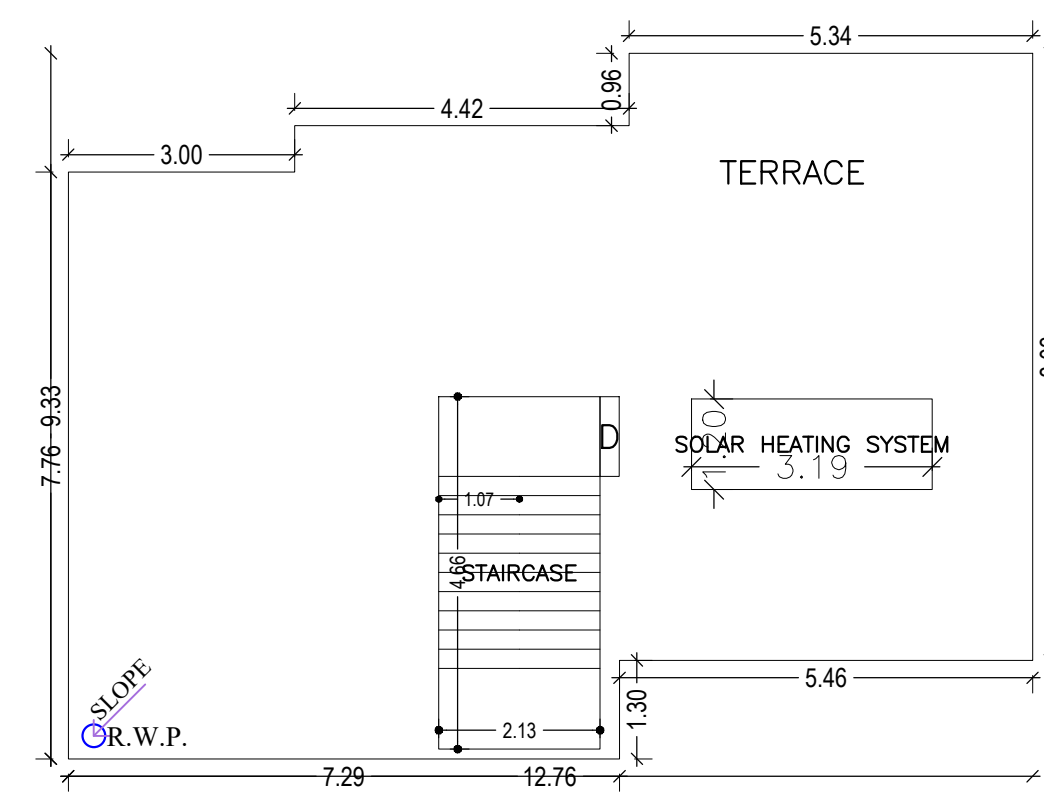

TERRACE FLOOR PLAN
(SCALE 1:100)

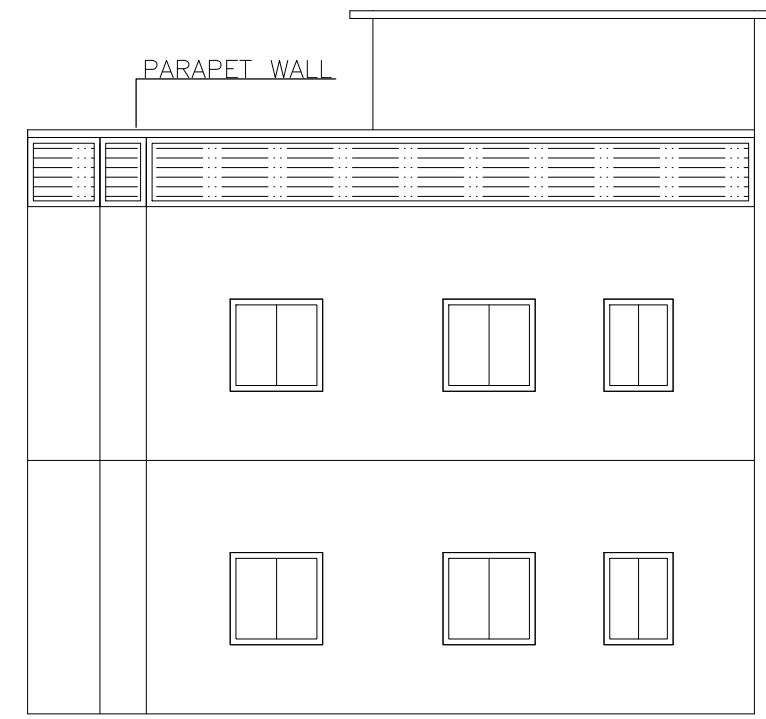
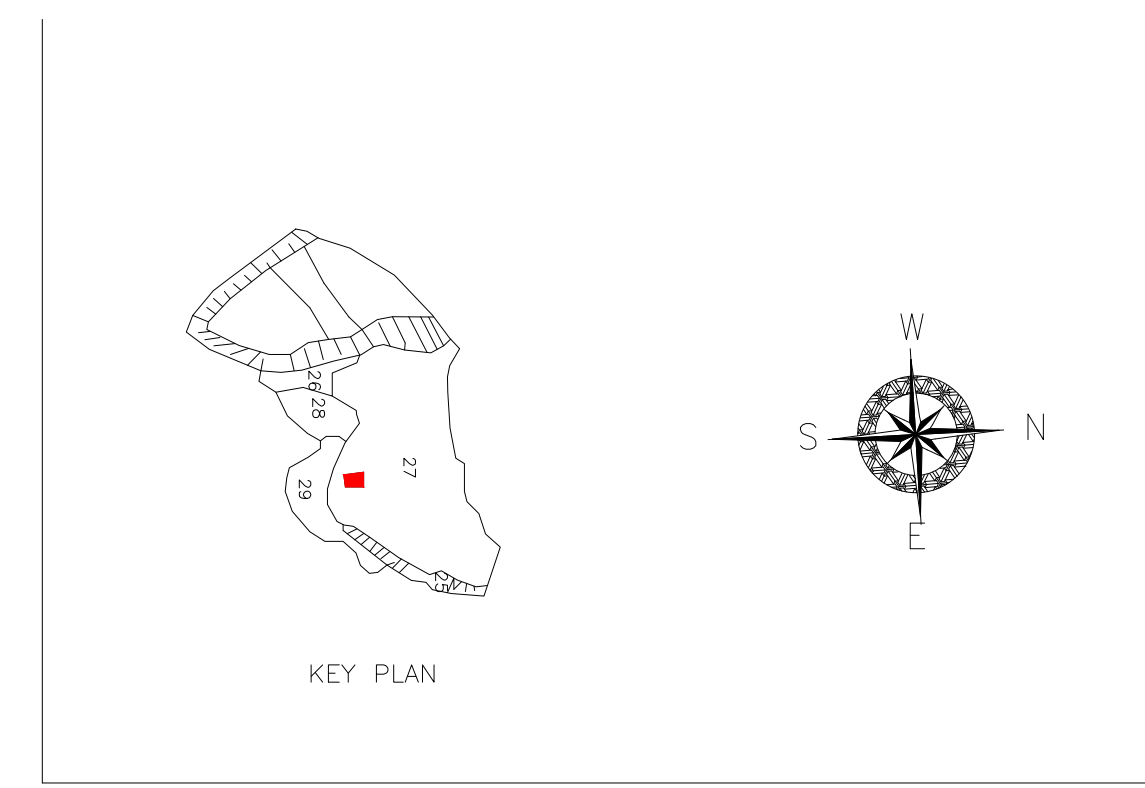

LEFT ELEVATION

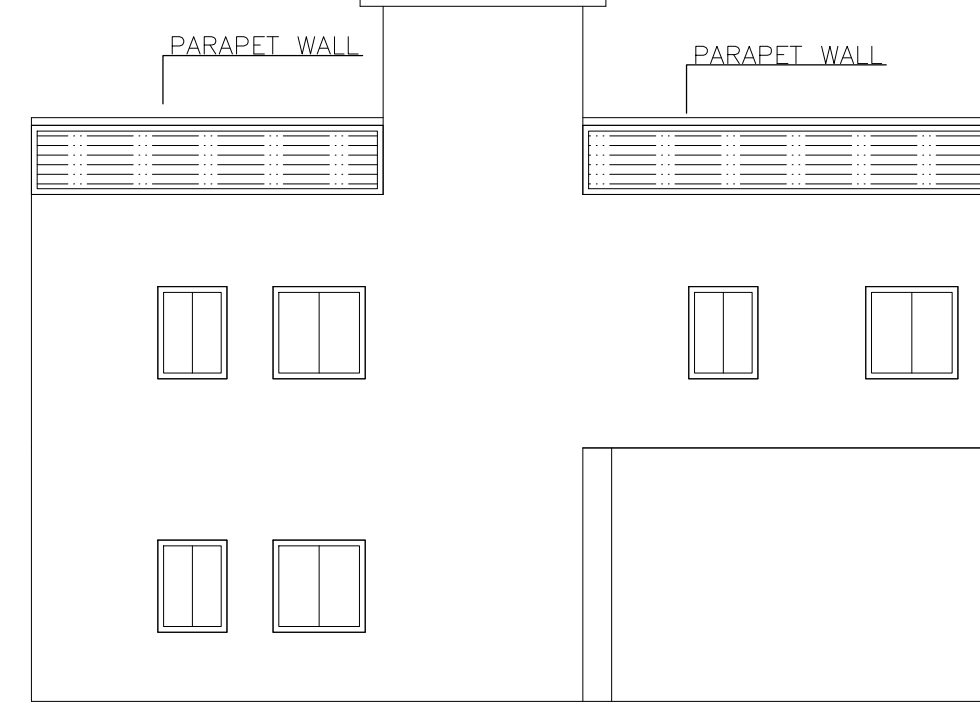

FRONT ELEVATION

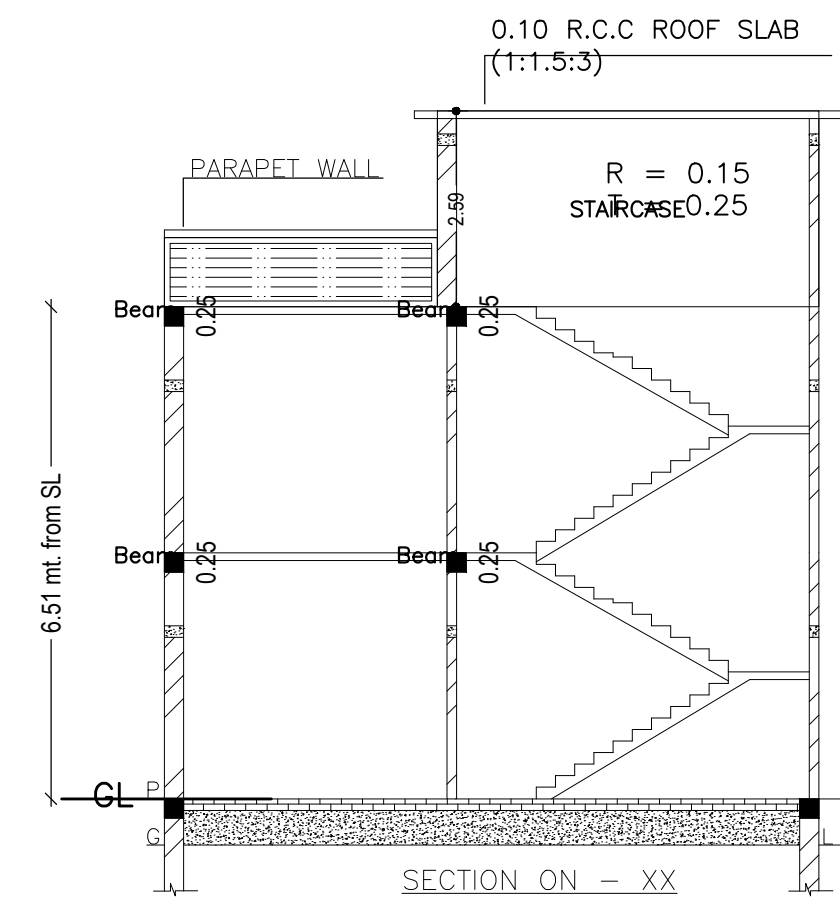

SECTION ON - XX

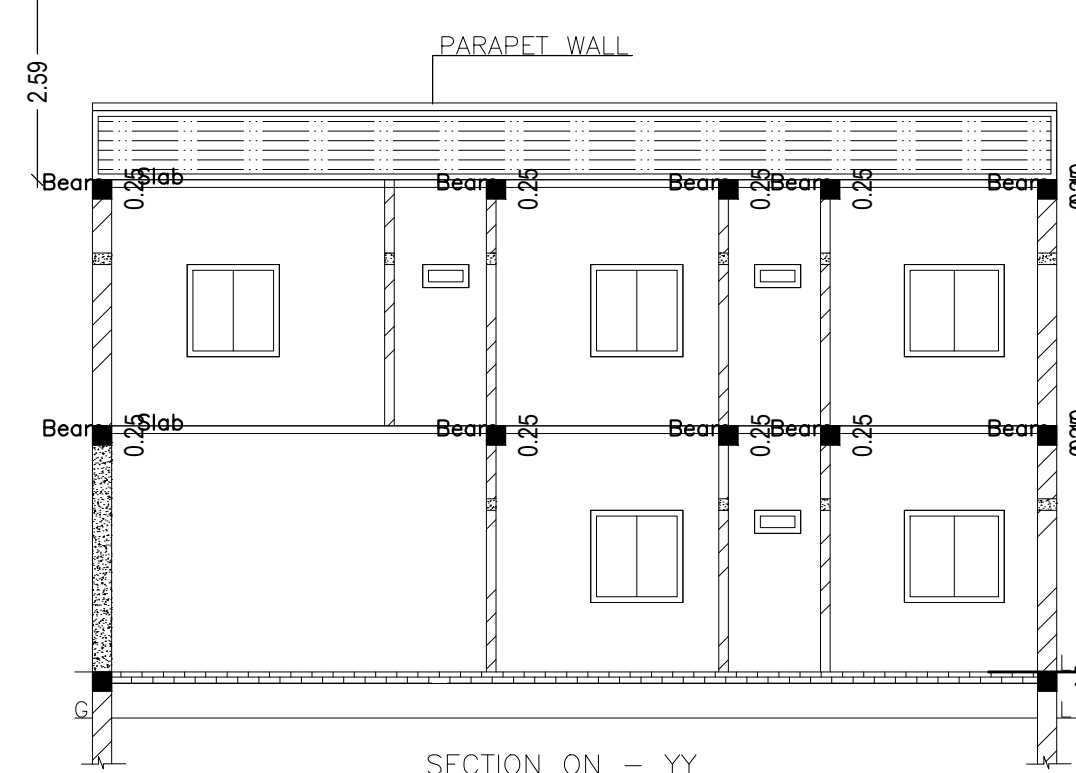

SECTION ON - YY

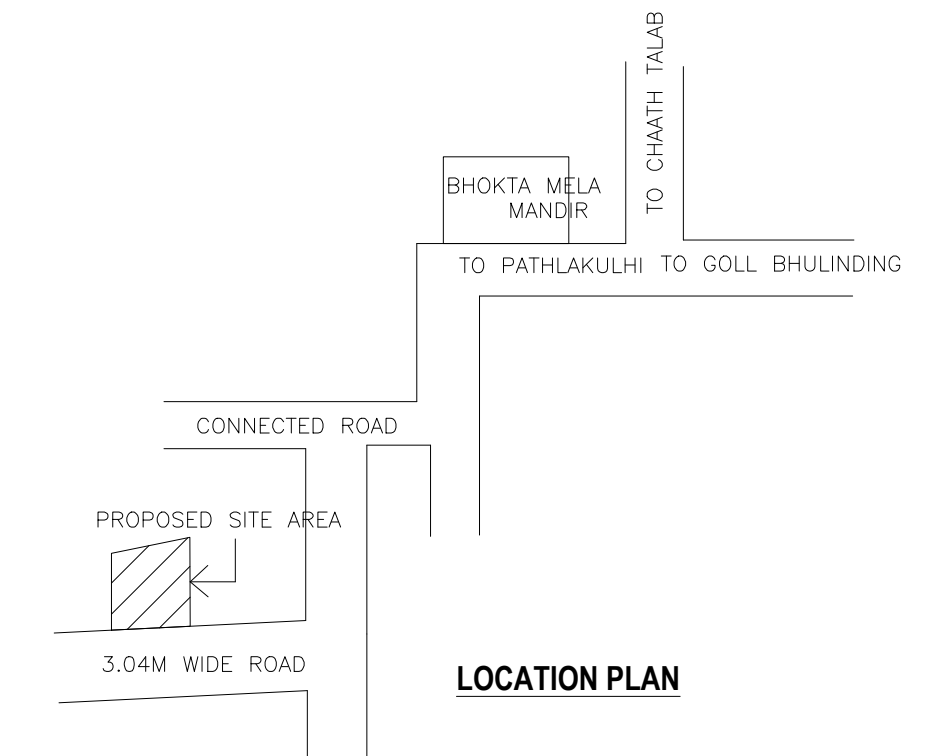

LOCATION PLAN

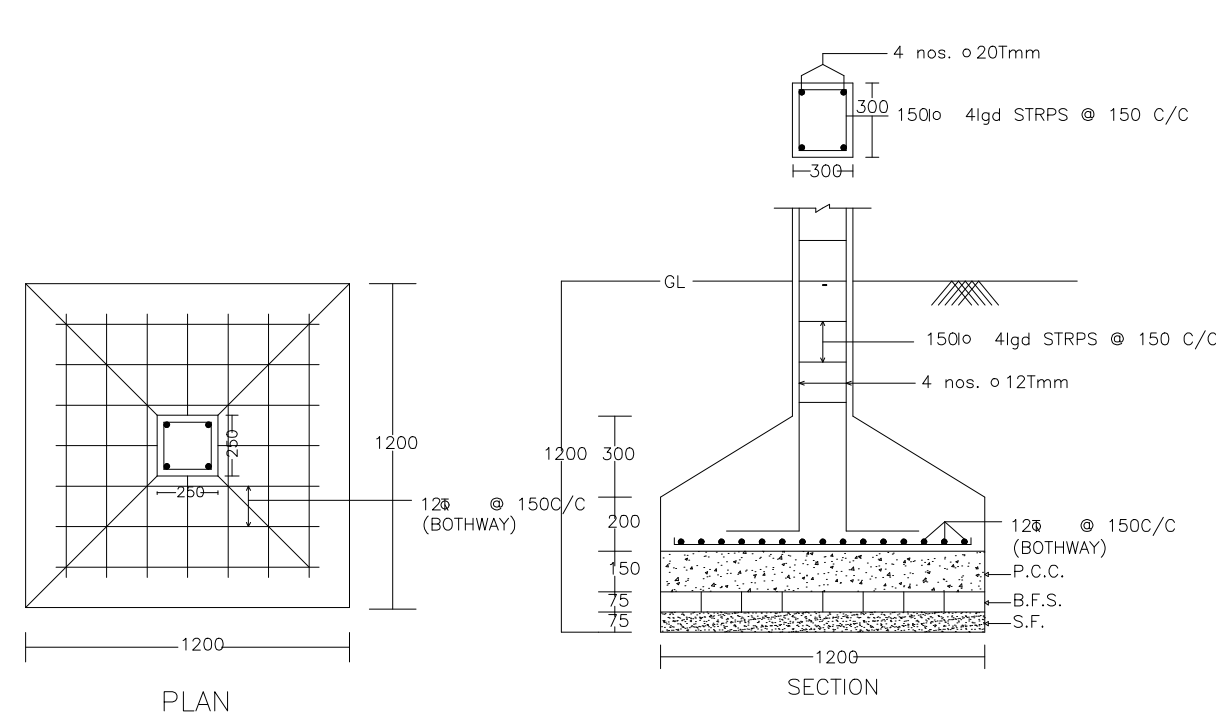

DETAIL OF COLUMNS

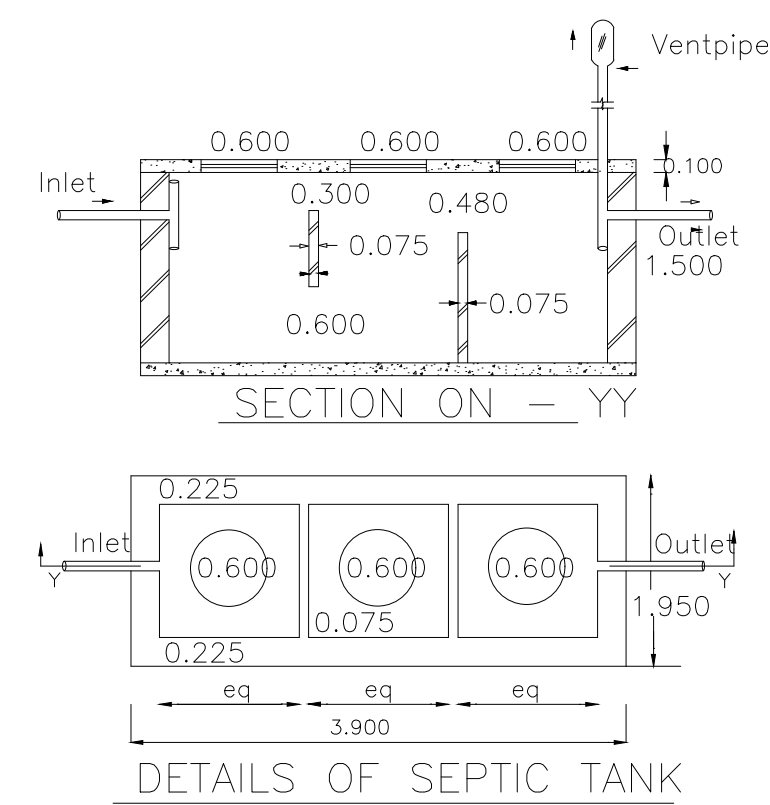

DETAILS OF SEPTIC TANK

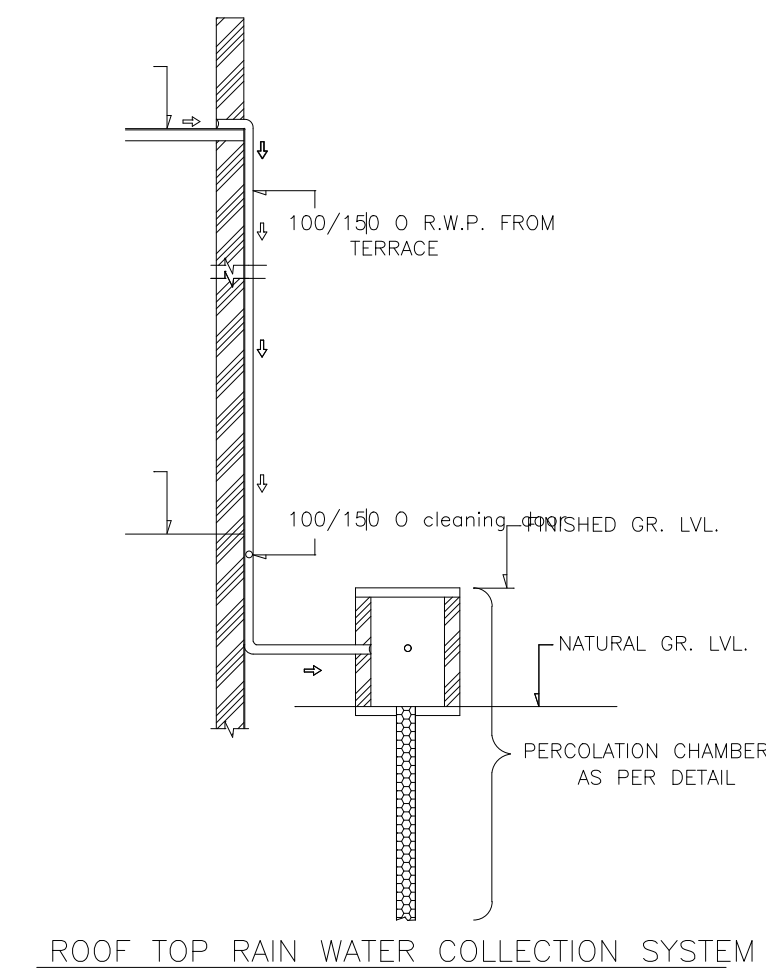

ROOF TOP RAIN WATER COLLECTION SYSTEM

LTP NAME AND SIGNATURE	STRUCTURAL ENG'S NAME AND SIGNATURE	BUILDER NAME AND SIGNATURE	DIGITAL SIGNATURE
ABHISHEK KUMAR DMC/DFTMN/0013/2020			