

Building USE/SUBUSE Details

Building Name	Building Use	Building SubUse	Building Structure
A (BUILDING)	Residential	Bungalow/ Dwelling / Non Apartment	Non-Highrise

SCHEDULE OF DOOR:

BUILDING NAME	NAME	LENGTH	HEIGHT	NOS
A (BUILDING)	D	0.76	2.10	01
A (BUILDING)	D	0.90	2.10	03
A (BUILDING)	D	0.91	2.10	02
A (BUILDING)	D	1.22	2.10	02

SCHEDULE OF WINDOW/VENTILATION:

BUILDING NAME	NAME	LENGTH	HEIGHT	NOS
A (BUILDING)	V	0.90	1.20	01
A (BUILDING)	W	1.80	1.20	10

Building :A (BUILDING)

Floor Name	Total Built Up Area (Sq.mt.)	Proposed FAR Area (Sq.mt.) Resi.	Total FAR Area (Sq.mt.)	Total Consumed Additional FAR Area (Sq.mt.)	Tnmt (No.)
Ground Floor	41.93	41.93	41.93	41.93	01
First Floor	41.93	41.93	41.93	41.93	00
Terrace Floor	0.00	0.00	0.00	0.00	00
Total:	83.86	83.86	83.86	83.86	01
Total Number of Same Buildings	1				
Total:	83.86	83.86	83.86	83.86	01

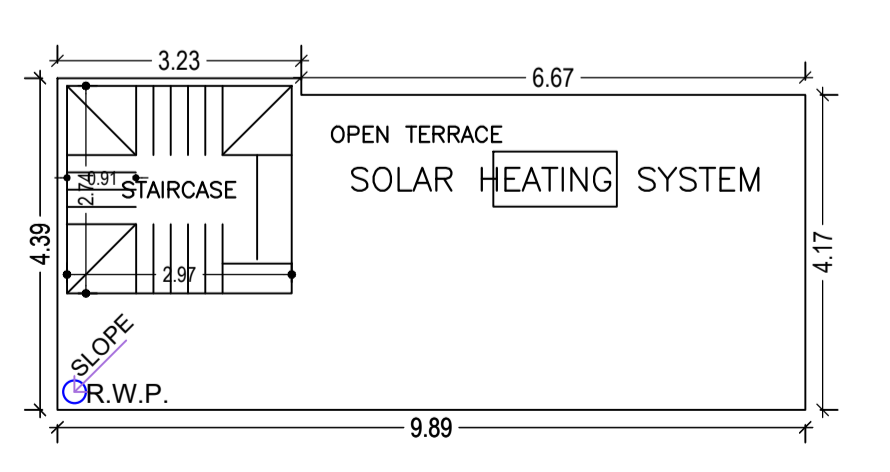
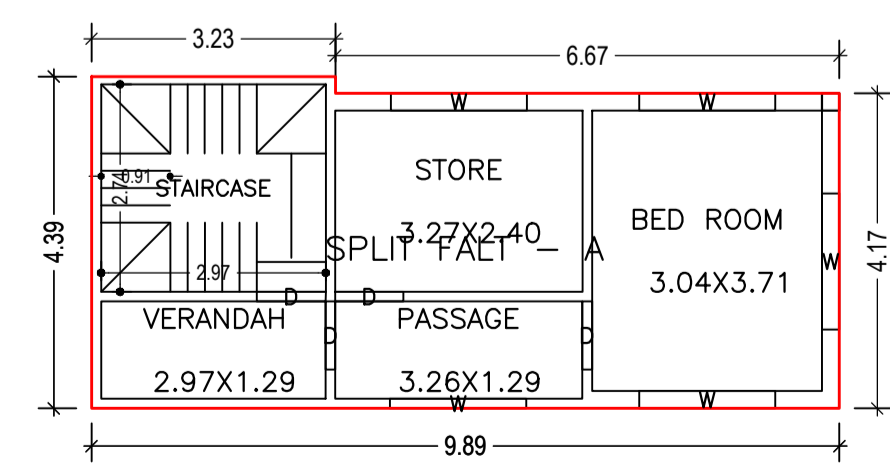
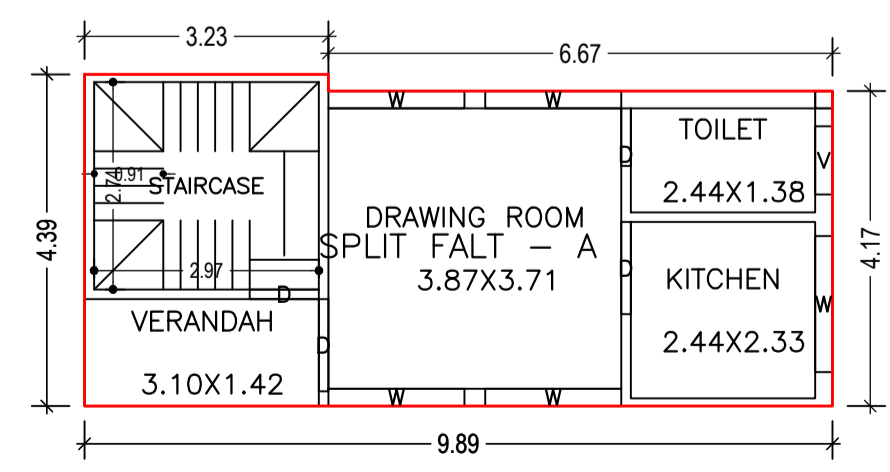

AREA STATEMENT		VERSION NO. : 1.0.62
DHANBAD MUNICIPAL CORPORATION		VERSION DATE: 16/10/2020
PROJECT DETAIL:		
Region: JHARKHAND URBAN	Plot Use: Residential	
LOCAL BODIES	Plot SubUse: Bungalow/ Dwelling / Non Apartment	
District: DHANBAD	PlotNearby/ReligiousStructure: NA	
Authority: DHANBAD MUNICIPAL CORPORATION	Inward_No: DMC/BP/0049/W23/2022	PlotSubPlot No: 1856 (Old), 2418 (New)
Application Type: General Proposal	North: Plot No. - NEW PLOT NO. 2298	South: Plot No. - PART OF THIS PLOT
Project Type: Building Permission	Nature of Development: New	East: Plot No. - NEW PLOT NO. 2421
Location of Development Area: Old Area	West: Road Width - 3.66	
AREA DETAILS:		
AREA OF PLOT (Minimum)	(A)	SQ.MT. 83.42
Deduction for NetPlot Area		3.29
Surrender Free of Cost		3.29
NET AREA OF PLOT(Gross Plot Area - Deduction from Gross Plot area)	(A-Deductions)	80.13
Deduction for Balance Plot Area(from Gross Plot Area)		3.29
Surrender Free of Cost		15.27
Common Plot		18.56
BALANCE AREA OF PLOT(Net Plot Area - Recreational/Amenity space)	(A-Deductions)	64.86
PLOT AREA FOR COVERAGE(Net Plot Area)	(A-Deductions)	80.13
Plot Area for FAR (Net Plot Area + Road/Widening Area)	(A-Deductions)	83.42
COVERAGE CHECK		
Permissible Coverage area (70.00 %)		56.09
Proposed Coverage Area (52.33 %)		41.93
Total Prop. Coverage Area (52.33 %)		41.93
Balance coverage area (17.67 %)		14.16
FAR CHECK		
Perm. FAR Area (1.20)		100.10
Total Perm. FAR area		100.10
Residential FAR		83.87
Proposed FAR Area		83.87
Total Proposed FAR Area		83.87
Consumed FAR (Factor)		1.01
Balance FAR Area		16.23
BUILT UP AREA CHECK		
Total Proposed BuiltUp Area		83.86
ARCHITECT (Regd)		PARTHA - PAL
ENGINEER (Regd)		
SUPERVISOR (Regd)		
OWNER (Regd)		SRI. SOMNATH MITRA.
DEVELOPMENT AUTHORITY		LOCAL BODY

COLOR INDEX	
PLOT BOUNDARY	Black
ABUTTING ROAD	Red
PROPOSED CONSTRUCTION	Green
COMMON PLOT	Yellow
ROAD WIDENING AREA	Blue
EXISTING (To be retained)	Orange
EXISTING (To be demolished)	Purple

Buildingwise Floor FAR Details

Floor Name	Building Name A (BUILDING)		Total	
	Proposed Built Up Area (Sq.mt.)	Proposed FAR Area (Sq.mt.)	Total Proposed Built Up Area (Sq.mt.)	Total FAR Area (Sq.mt.)
Ground Floor	41.93	41.93	41.93	41.93
First Floor	41.93	41.93	41.93	41.93
Terrace Floor	0.00	0.00	0.00	0.00
Total:	83.86	83.86	83.86	83.86

FAR & Tenement Details (Table 4c-1)

Building	No. of Same Bldg	Total Built Up Area (Sq.mt.)	Proposed FAR Area (Sq.mt.) Resi.	Total FAR Area (Sq.mt.)	Total Consumed Additional FAR Area (Sq.mt.)	Tnmt (No.)
A (BUILDING)	1	83.86	83.86	83.86	83.86	01
Grand Total:	1	83.86	83.86	83.86	83.86	01

UnitBUA Table for Building :A (BUILDING)

FLOOR	Name	UnitBUA Type	UnitBUA Area	Carpet Area	No. of Rooms	No. of Tenement
GROUND FLOOR PLAN	SPLIT FALT - A	FLAT	83.87	83.76	4	1
FIRST FLOOR PLAN	SPLIT FALT - A	FLAT	0.00	0.00	4	0
Total:	-	-	83.87	83.76	8	1

LTP NAME AND SIGNATURE	STRUCTURAL ENG'S NAME AND SIGNATURE	BUILDER NAME AND SIGNATURE	DIGITAL SIGNATURE
PARTHA - PAL DMC/ENG/0021/2016			