

Proposal Basic Information	
Proposal File No.	DMC/BP/0002/W22/2022
Owner Name	MANJU SINHA
Khata No	OLD-42, NEW-25
Plot No	OLD-814,NEW-1189
Village Name	Bhelaland
Use	Residential
SubUse	Bungalow/ Dwelling / Non Apartment

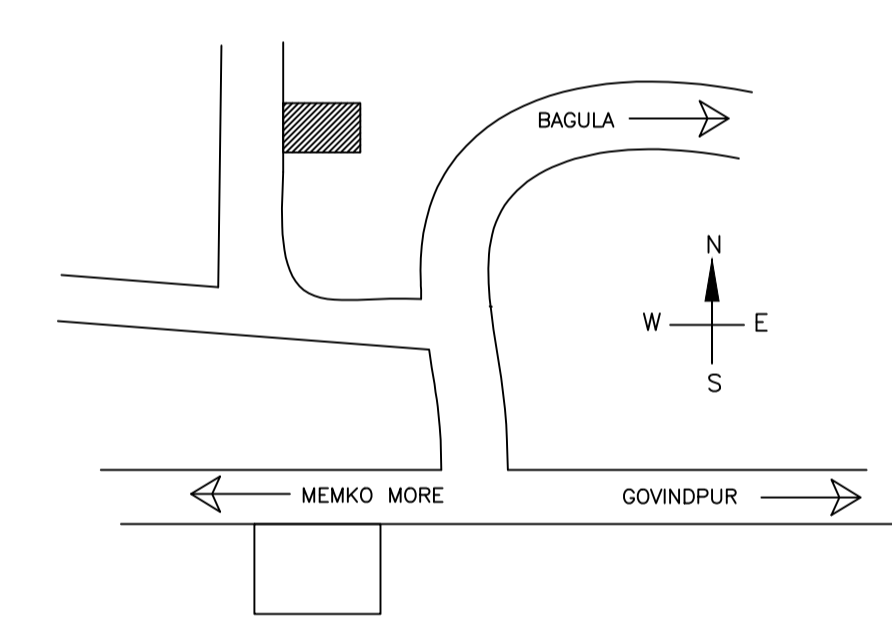
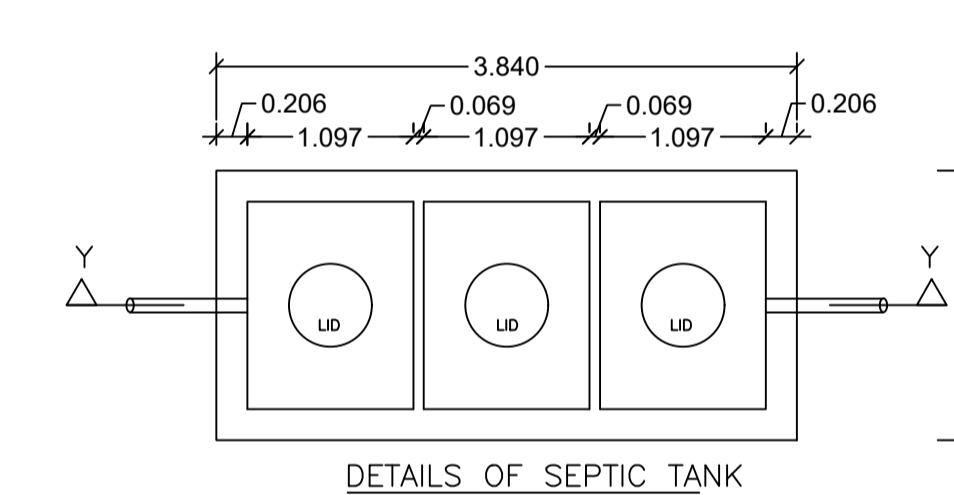
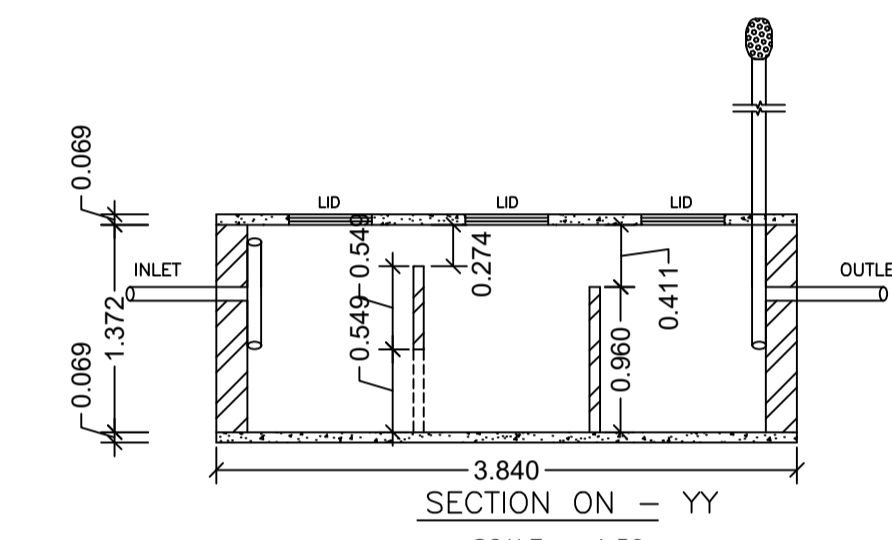
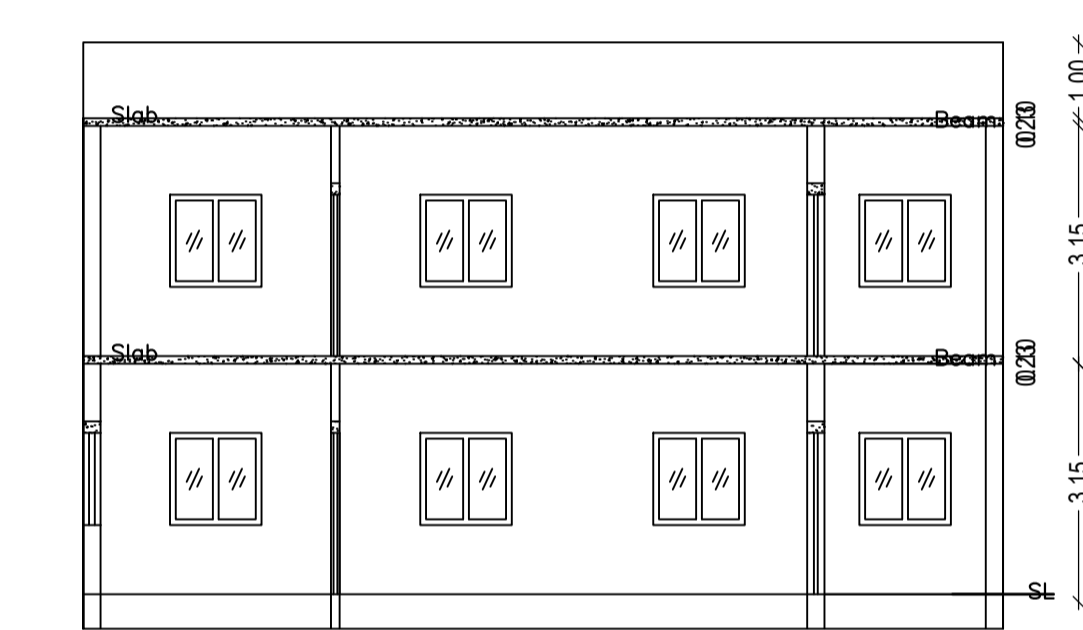
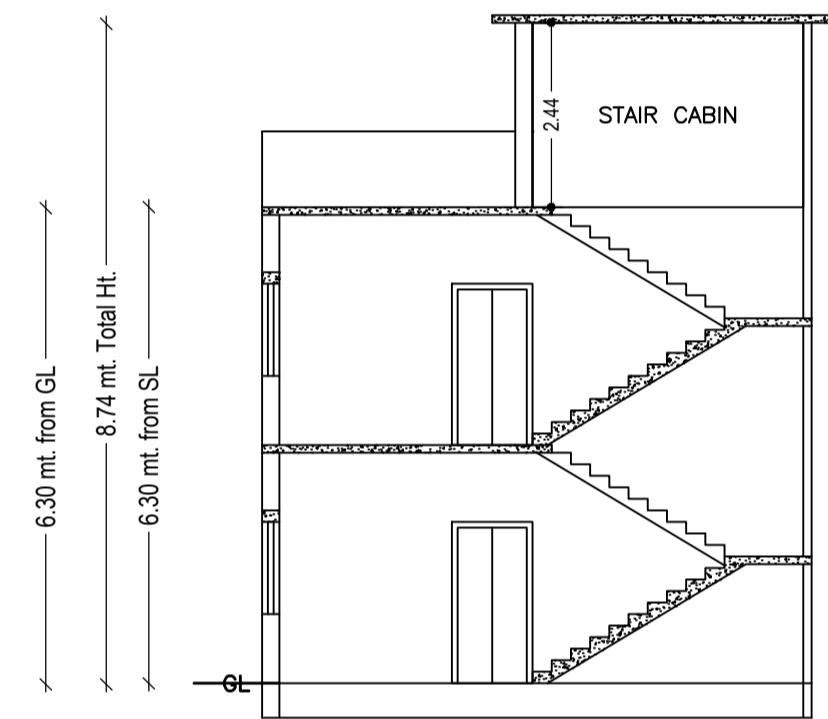
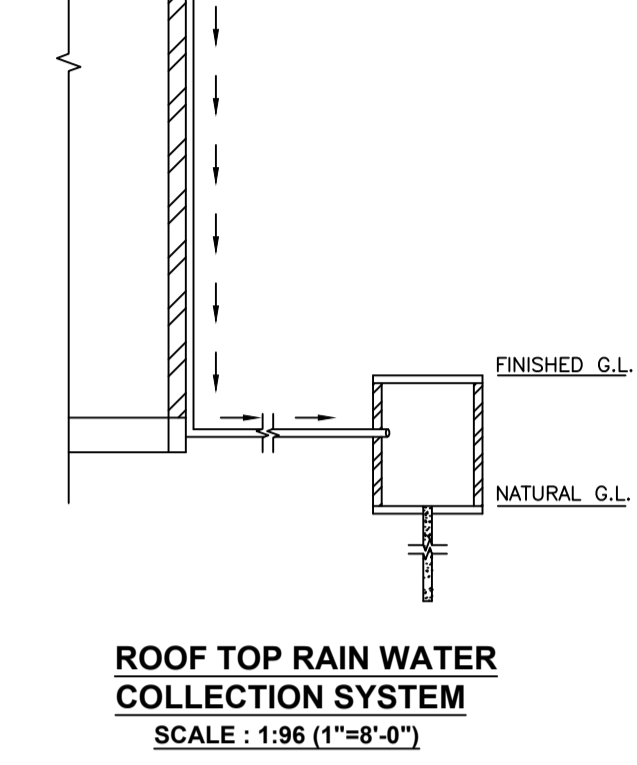
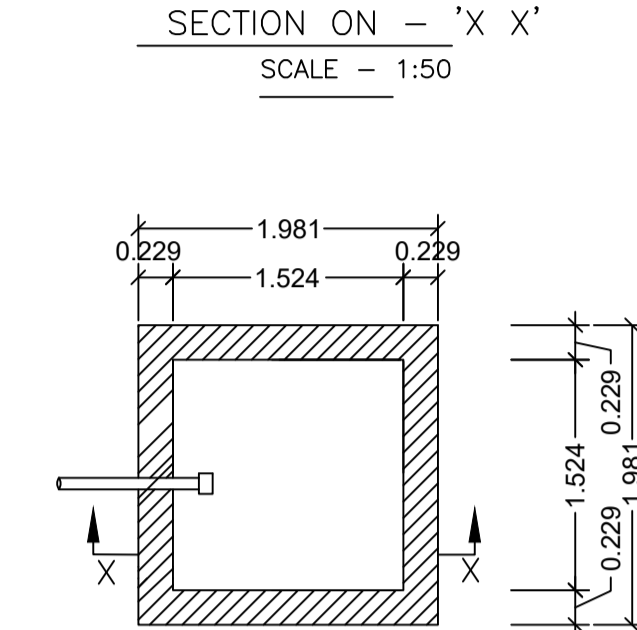
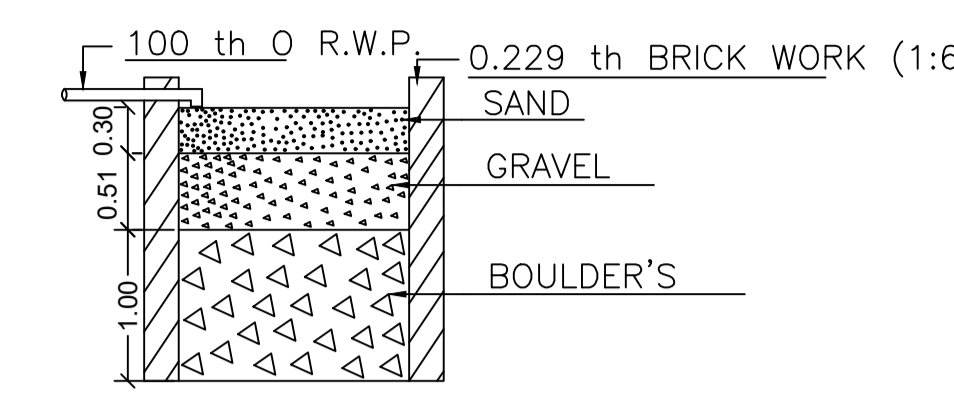
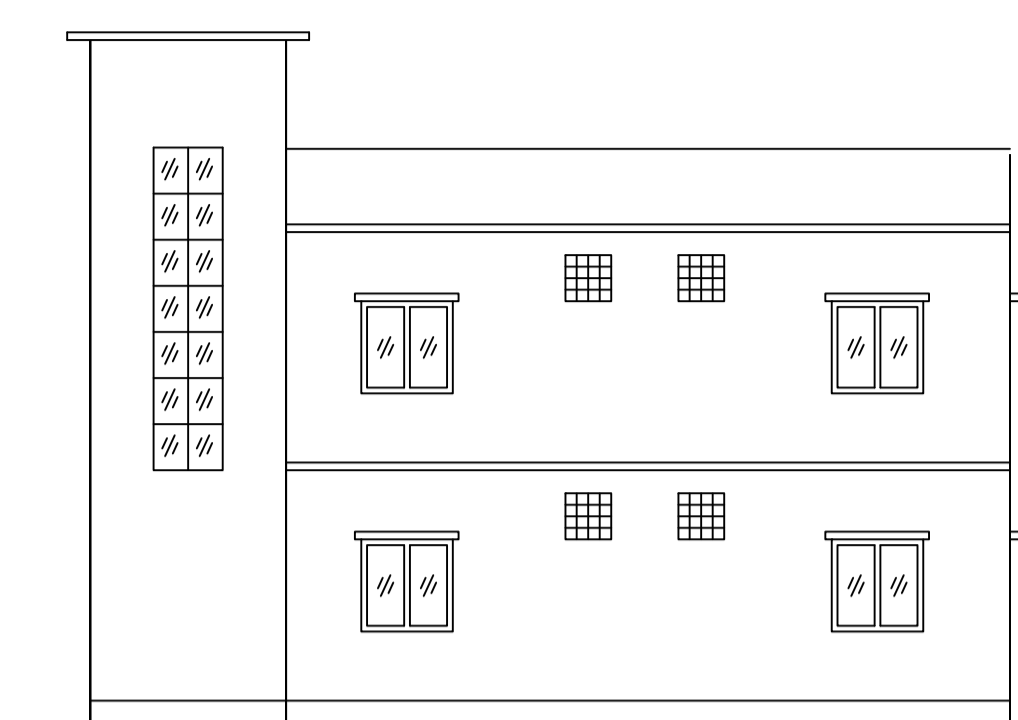
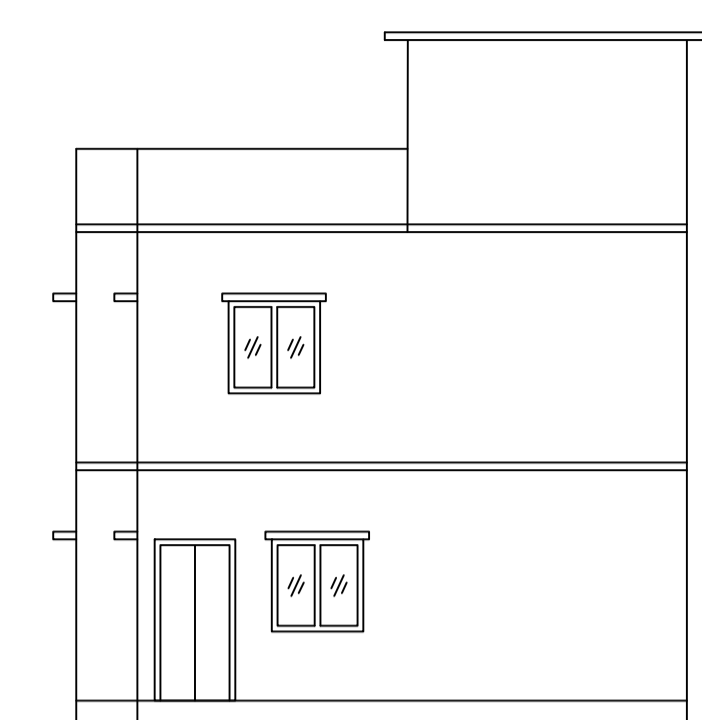
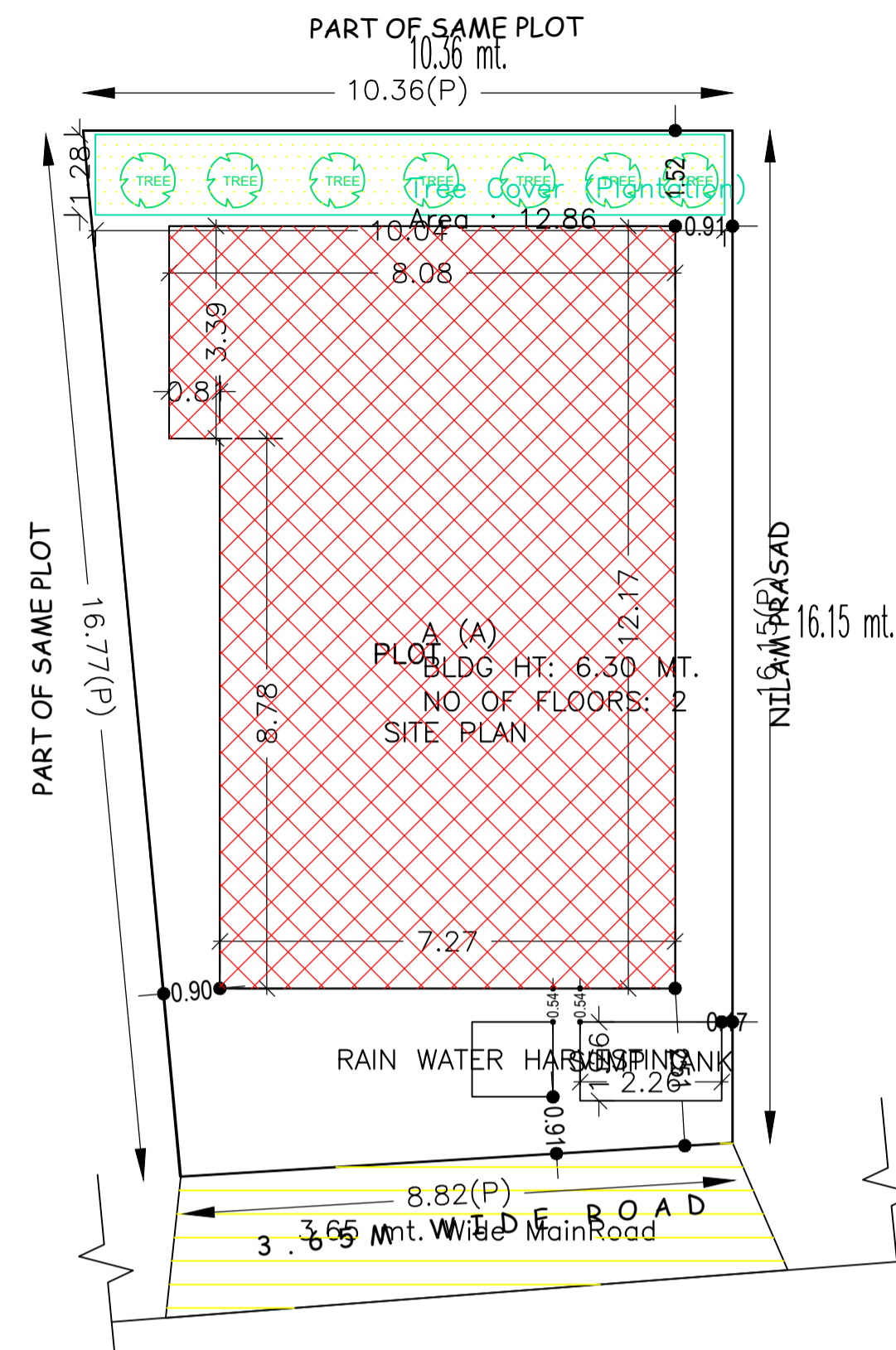

AREA STATEMENT		VERSION NO. : 1.0.61
DHANBAD MUNICIPAL CORPORATION		VERSION DATE: 16/10/2020
PROJECT DETAIL:		
Region: JHARKHAND URBAN LOCAL BODIES	Plot Use: Residential	
District: DHANBAD	Plot SubUse: Bungalow/ Dwelling / Non Apartment	
Authority: DHANBAD MUNICIPAL CORPORATION	Plot/Nearby/ReligiousStructure: NA	
Inward_No: DMC/BP/0002/W22/2022	Plot/SubPlot No: OLD-814-NEW-1189	
Application Type: General Proposal	North: Plot No. - PART OF SAME PLOT	
Project Type: Building Permission	South: Plot No. - NILAM PRASAD	
Nature of Development: New	East: Plot No. - PART OF SAME PLOT	
Location of Development Area: Old Area	West: Road Width - 3.65 M WIDE ROAD	
AREA OF PLOT (Minimum)	(A)	SQ.MT. 157.62
NET AREA OF PLOT(Gross Plot Area - Deduction from Gross Plot area)	(A-Deductions)	157.62
Deduction for Balance Plot Area(from Gross Plot Area)		
Common Plot		12.86
BALANCE AREA OF PLOT(Net Plot Area - Recreational/Amenity space)	(A-Deductions)	144.77
PLOT AREA FOR COVERAGE(Net Plot Area)	(A-Deductions)	157.62
Plot Area for FAR (Net Plot Area + Road Widening Area)	(A-Deductions)	157.62
COVERAGE CHECK		
Permissible Coverage area (70.00 %)		110.33
Proposed Coverage Area (57.84 %)		91.16
Total Prop. Coverage Area (57.84 %)		91.16
Balance coverage area (12.16 %)		19.17
FAR CHECK		
Perm. FAR Area (1.50)		236.43
Total Perm. FAR area		236.43
Residential FAR		182.33
Proposed FAR Area		182.33
Total Proposed FAR Area		182.33
Consumed FAR (Factor)		1.16
Balance FAR Area		54.10
BUILT UP AREA CHECK		
Total Proposed BuiltUp Area		182.32
ARCHITECT (Regd)	SANJEEV KUMAR RAY	
ENGINEER (Regd)		
SUPERVISOR (Regd)		
OWNER (Regd)	MANJU SINHA	
DEVELOPMENT AUTHORITY		LOCAL BODY

COLOR INDEX	
PLOT BOUNDARY	Black
ABUTTING ROAD	Green
PROPOSED CONSTRUCTION	Red
COMMON PLOT	Yellow
ROAD WIDENING AREA	Blue
EXISTING (To be retained)	Grey
EXISTING (To be demolished)	White

Floor Name	Building Name		Total	
	Proposed Built Up Area (Sq.mt.)	Proposed FAR Area (Sq.mt.)	Total Proposed Built Up Area (Sq.mt.)	Total FAR Area (Sq.mt.)
Ground Floor	91.16	91.16	91.16	91.16
First Floor	91.16	91.16	91.16	91.16
Terrace Floor	0.00	0.00	0.00	0.00
Total :	182.32	182.32	182.32	182.32

Building Name	Building Use	Building SubUse	Building Structure
A (A)	Residential	Residential Bldg/Apartment	Non-Highrise

Building	No. of Same Bldg	Total Built Up Area (Sq.mt.)	Proposed FAR Area (Sq.mt.) Resi.	Total FAR Area (Sq.mt.)	Total Consumed Additional FAR Area (Sq.mt.)	Trmt (No.)
A (A)	1	182.32	182.32	182.32	182.32	01
Grand Total :	1	182.32	182.32	182.32	182.32	01

Floor Name	Total Built Up Area (Sq.mt.)	Proposed FAR Area (Sq.mt.) Resi.	Total FAR Area (Sq.mt.)	Total Consumed Additional FAR Area (Sq.mt.)	Tnmt (No.)
Ground Floor	91.16	91.16	91.16	91.16	01
First Floor	91.16	91.16	91.16	91.16	00
Terrace Floor	0.00	0.00	0.00	0.00	00
Total :	182.32	182.32	182.32	182.32	01

SCHEDULE OF DOOR:

BUILDING NAME	NAME	LENGTH	HEIGHT	NOS
A (A)	D	0.76	2.10	04
A (A)	D	0.91	2.10	04
A (A)	D	1.07	2.10	07

SCHEDULE OF WINDOW/VENTILATION:

BUILDING NAME	NAME	LENGTH	HEIGHT	NOS
A (A)	V	0.61	1.20	06
A (A)	W	1.22	1.20	18

UnitBUA Table for Building :A (A)

FLOOR	Name	UnitBUA Type	UnitBUA Area	Carpet Area	No. of Rooms	No. of Tenement
GROUND FLOOR PLAN	SPLIT A	FLAT	182.33	182.26	8	1
FIRST FLOOR PLAN	SPLIT A	FLAT	0.00	0.00	8	0
Total:	-	-	182.33	182.26	16	1

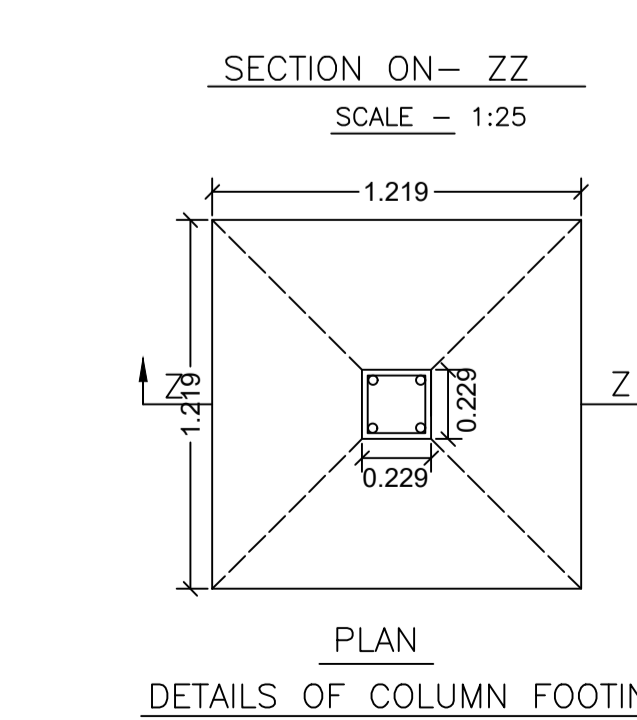
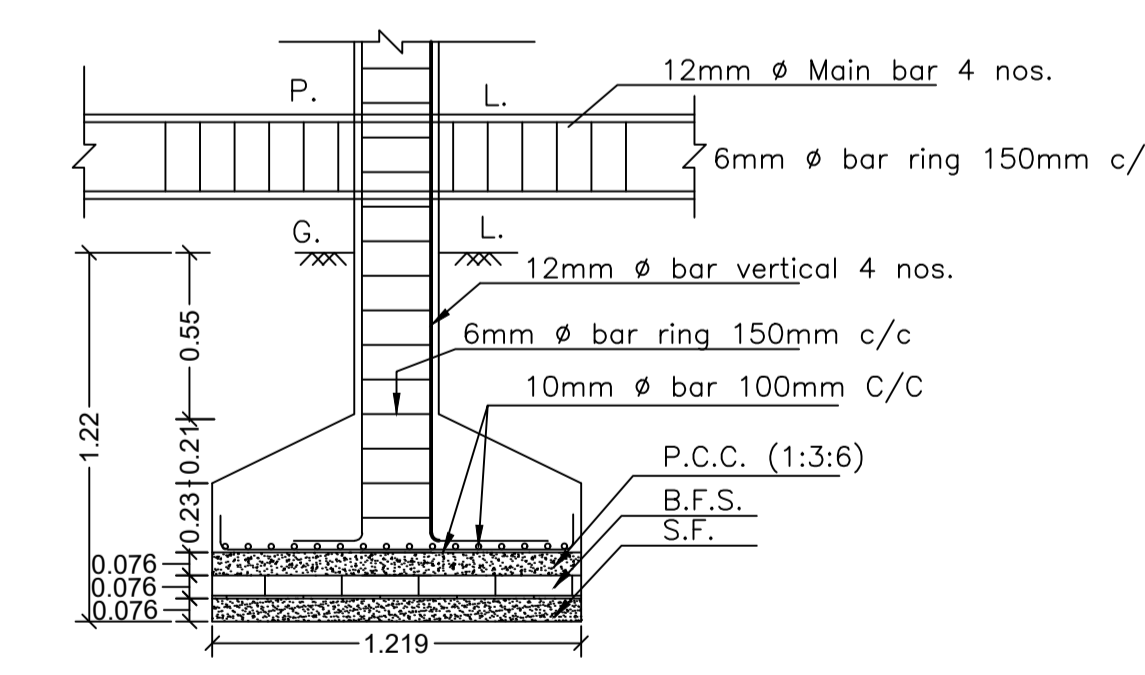
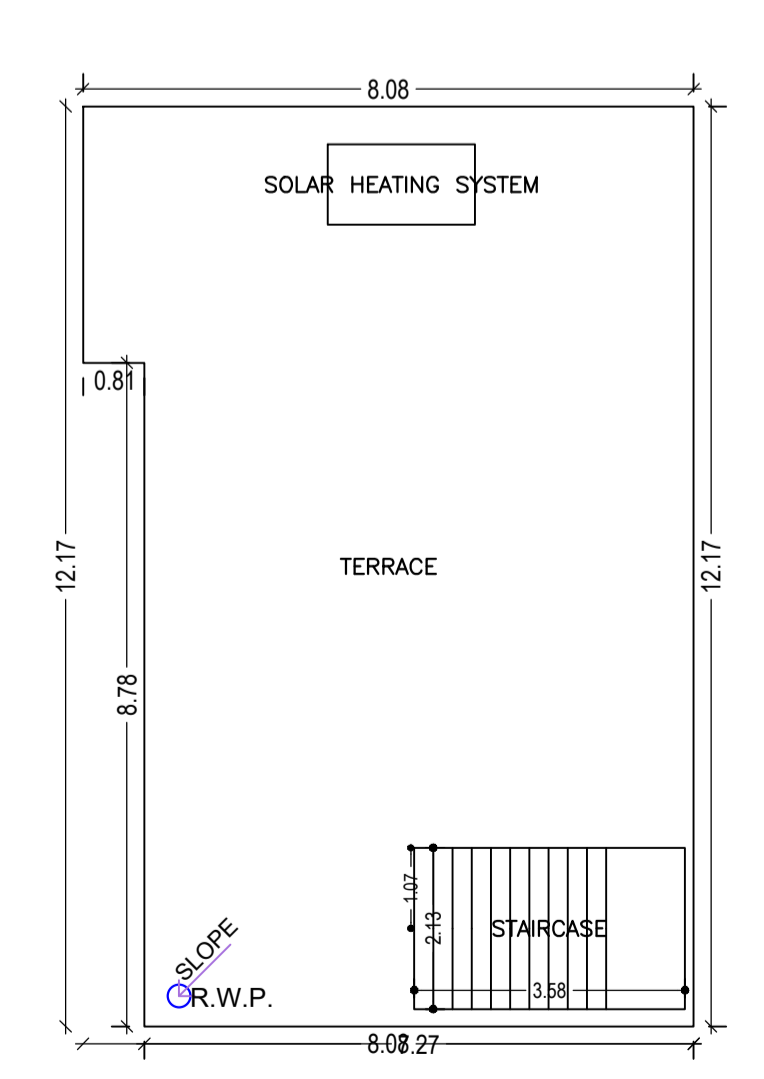
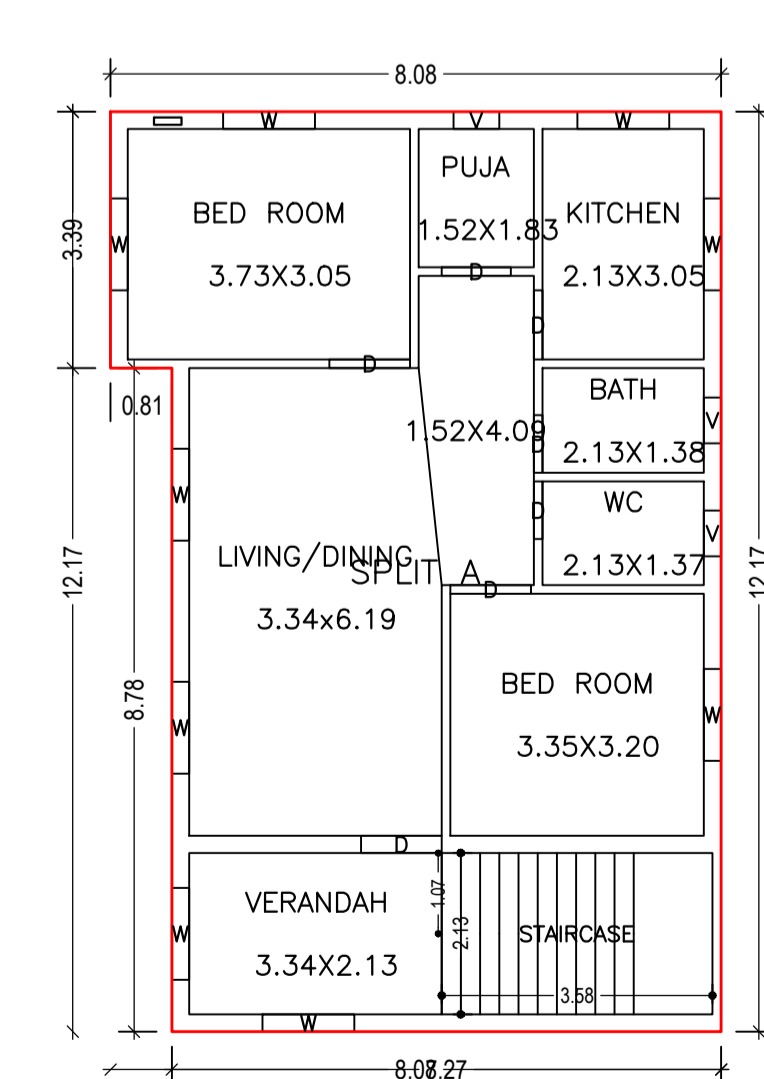
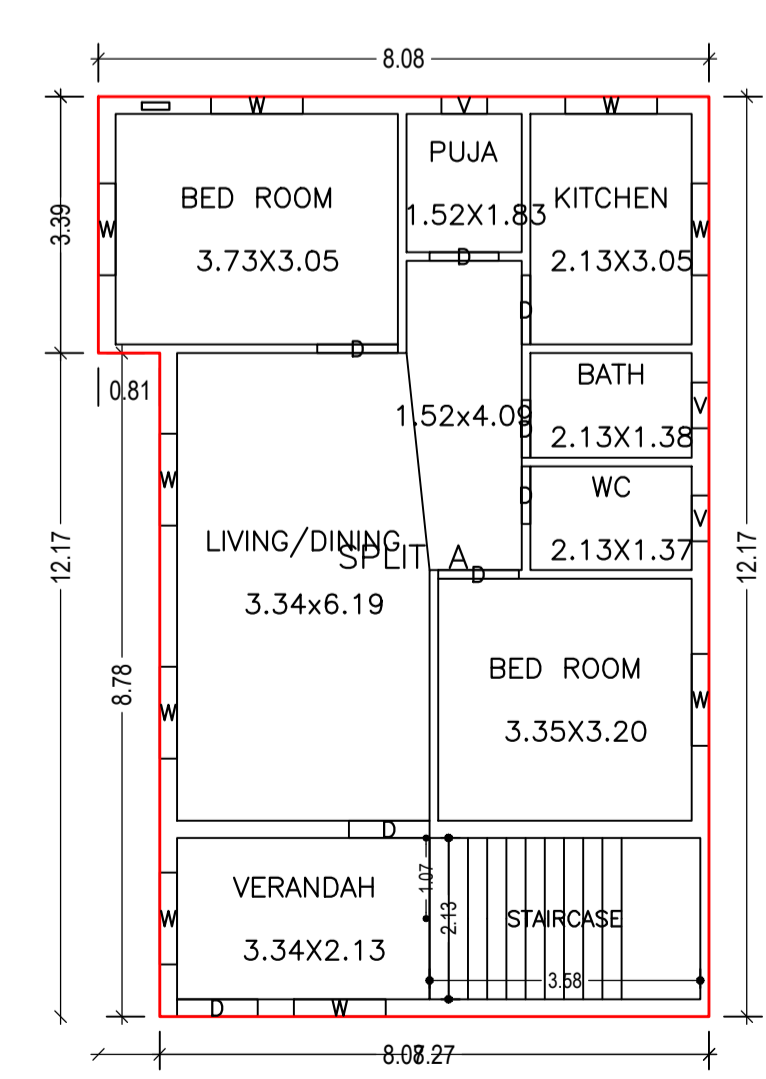

LTP NAME AND SIGNATURE	STRUCTURAL ENG'S NAME AND SIGNATURE	BUILDER NAME AND SIGNATURE	DIGITAL SIGNATURE
SANJEEV KUMAR RAY DMC/ENG/0001/2019			